

# MICROBIOLOGY

**Higher secondary - Second year**

*Untouchability is a sin*  
*Untouchability is a crime*  
*Untouchability is inhuman*

**TAMIL NADU**  
**TEXT BOOK CORPORATION**  
COLLEGE ROAD, CHENNAI-600 006

**CHAIRPERSON AND AUTHOR**

**Dr. T. Sundararaj,**

Professor and Head, Department of Microbiology  
Dr.A.L.Mudaliar Post Graduate Institute of Basic Medical Sciences  
University of Madras, Taramani, Chennai – 600 113

**AUTHORS**

**Dr. S. Anthoniraj,**

Dean, Anbil Dharmalingam Agricultural College  
and Research Institute,  
Trichy-620 009

**Dr. N. Kannan,**

Director, School of Biotechnology,  
KSR College of Technology,  
Thokkavadi, Thiruchengode - 637 209

**Dr. S.M. Muthukaruppan,**

Professor, Department of Microbiology,  
Faculty of Agriculture,  
Annamalai Nagar- 608002

**Mrs. Aswathy Sundararaj,**

Lecturer in Microbiology,  
Tamilnadu College of Physiotherapy  
Injambakkam, Chennai - 600 041

**Price: Rs.**

This book has been prepared by the Directorate of School  
Education on behalf of the Government of Tamilnadu

This book has been printed on 60 gsm paper

## Contents

	Page
<b>Section I - General Microbiology</b>	
1.0 Theory of biogenesis	... 1
2.0 Microscopy	... 13
3.0 Control of microorganisms	... 21
4.0 Energy and enzymes	... 31
<b>Section II - Environmental, food and Industrial Microbiology</b>	
5.0 Environmental Microbiology	... 51
6.0 Food Microbiology	... 63
7.0 Industrial Microbiology	... 77
<b>Section III - Medical Bacteriology</b>	
8.1 Pathogenic attributes of Bacteria	... 91
8.2 Normal flora of the body	... 97
8.3 Staphylococcus aureus	... 103
8.4 Streptococcus pyogenes	... 109
8.5 Corynebacterium diphtheriae	... 119
8.6 Salmonella	... 127
8.7 Shigella	... 135
8.8 Vibrio	... 138
8.9 Clostridium tetani	... 142
8.10 Clostridium botulinum	... 147
8.11 Chlamydia	... 151
8.12 Mycoplasma	... 158

#### **Section IV - Medical Parasitology, Mycology, Virology & Zoonosis**

8.13	Leishmania	...	163
8.14	Trypanosomes	...	171
8.15	Parasitic helminthes	...	178
8.16	Taenia solium	...	185
8.17	Candida albicans	...	189
8.18	Cryptococcus neoformans	...	193
8.19	Mycetoma	...	197
8.20	Herpes viruses	...	201
8.21	Hepatitis viruses	...	207
8.22	HIV	...	215
8.23	Brucellosis	...	221
8.24	Lyme disease	...	225

#### **Section V - Immunology**

9.1	Development of cells in thymus	...	229
9.2	Antigen and antigen presentation	...	232
9.3	Antibodies	...	241
9.4	Immunofluorescence	...	247
9.5	ELISA	...	255
9.6	Hypersensitivity reactions	...	259
9.7	Tissue transplantation	...	271
9.8	Vaccines	...	277

#### **Section VI -- Microbial genetics**

10.0	Microbial genetics	...	281
	<b>Practicals</b>	...	306
	Section I -- Evaluation	...	307
	Section II -- Evaluation	...	315
	Section III -- Evaluation	...	325
	Section IV -- Evaluation	...	339
	Section V -- Evaluation	...	355
	Section VI -- Evaluation	...	364

## SECTION - I

### GENERAL MICROBIOLOGY

#### Chapter - 1

#### THEORY OF BIOGENESIS

Biogenesis (Gr. Bio-life; genesis: origin) means that life originates from pre existing life. This denotes that life does not arise spontaneously or created from inanimate, and abiotic objects by God. Biogenesis involves parental organisms similar to the one formed. On the other hand **Abiogenesis** or the **Spontaneous generation theory** suggests that life originates spontaneously from dissimilar inanimate objects like stone.

Early men out of superstition, ignorance and due to fear surrounding the life believed that living organisms were created by God. In Greek mythology it was believed that Goddess Gaea created people from stones and other inanimate objects. It was also a belief that animals originated spontaneously from the soil, plants or other unlike animals. Aristotle (384-322BC), the great philosopher also taught the same. There were also others who advocated artificial propagation of bees based on the observation that meat exposed to warmth and air produced maggots. Recepties were also recommended for the manufacture of mice by putting some wheat grains, soiled linens and cheese into a receptacle and leaving it undisturbed. In reality the mice were not produced but attracted by the food. There were also intelligent and thoughtful men who doubted the spontaneous generation theory (Abiogenesis) and consequently there started a controversy over the origin of life.

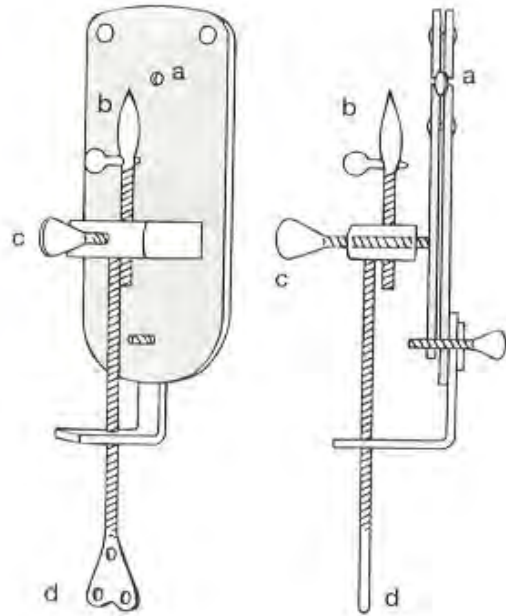
Although the creation of man from stones was discarded, the appearance of maggots and worms in exposed food material remained unexplained. Francisco Redi(1626-1697) demonstrated by covering the meat in a jar by a gauze, the flies attracted by the odour

laid eggs on gauze and maggots did not appear in the meat underneath clearly showing that the origin of maggots in exposed meat was due to flies. But still some people believed that tiny microbes developing in meat originated spontaneously. John Needham(1749) exposed meat to hot ashes and found the appearance of bacteria which were not present originally and therefore concluded that bacteria originated from meat. During the same time Lazzaro Spallanzani showed that when beef broth was boiled for an hour and if flasks were sealed after boiling and incubated no microbes appeared. This evidence failed to convince Needham who argued that air, essential for the spontaneous origin of microbes was excluded by sealing of flasks and therefore no life appeared. This was answered after 60-70 years independently when Franz schulze(1815-1873) passed the air through strong acid solution and Theodore Schwann (1810-1882), passed air through red hot tubes before letting it into the infusions. Microbes did not appear in the infusions in both the cases. It was argued that acid and heat destroyed the vital force in air and hence did not support growth. Schroder and von Dusch(1850) passed air through cotton into heated broth in flask in which no microbes appeared. The microbes present in air were filtered out by the cotton and hence no growth occurred. Thus appeared the use of cotton plug in microbiological laboratories.

#### **Anton Van Leeuwenhoek and his Microscopes:**

Anton van Leeuwenhoek (1632 – 1723) a contemporary of Robert Hook was born in Delft, Holland. Leeuwenhoek was a successful businessman and qualified himself as a surveyor and the official wine taster of Delft, Holland and in 1660 he was appointed chamber lane to chief judge, the sheriff's and the law officers of the city of Delft. He held the position for thirty-nine years. He had little formal education and never attended a university. He was ignorant of any language except Dutch. He was fortunate that his work was recognized in his lifetime itself. A society for scientific work publication was established in England and was called as Royal society. The society invited Leeuwenhoek to communicate his observation to its members. He was elected as a fellow of the society in 1680. For almost fifty years until his death in 1723, Leeuwenhoek transmitted his discoveries to the

royal society in the form of long letters written in Dutch. Most of his discoveries were translated and published in English in the proceedings of the royal society. Leeuwenhoek made glass lenses by grinding and mounting them into brass contraptions and he called them as microscopes and almost spherical lens (a) was mounted between two small metal plates. The specimen was placed on the adjustable needle mounted above the lens. The needle is a blunt pin (b) and was brought into focus by manipulating two screws (c) and (d) (figure – 1). No change of magnification was possible and the magnifying power of each microscope being an intrinsic property of its lens.



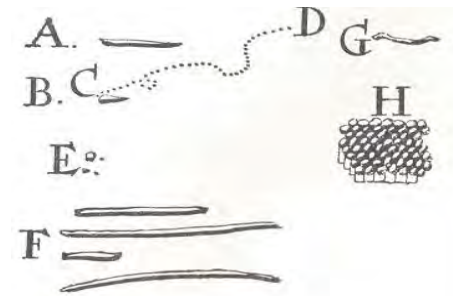
**Fig. 1-1.** Drawings of a microscope used by Anton van Leeuwenhoek

He was able to view the specimens on the blunt pin by holding the microscope very close to his eye and squinted through the lens. His microscope was able to magnify from about 50 to 300 times. Leeuwenhoek constructed hundreds of such instruments. Microscopy

was a fascinating hobby for Leeuwenhoek and he spent greater part of his life making microscopes, observing the microscopic world and maintained records of his observations in simple language. He made observations on the structure of seed and embryos of plants, small invertebrate animals, spermatozoa and Red blood cells.

However his greatest discovery is of the microbial world of animalcules. He sent the 18<sup>th</sup> letter to the society on October 9, 1676 and gave the first description of unicellular animals such as protozoa and the smaller microorganisms such as bacteria. He had looked at water samples from fresh water from river, well water, rainwater and seawater.

His descriptions were accurate. One of Leeuwenhoek's most publicized observations was of bacteria from the human mouth (figure). He described rod shaped bacteria as bacilli, spherical bacteria as cocci and bacteria with spiral body that resemble cork screws as spirochetes. Starting in the 1670s Leeuwenhoek wrote numerous letters to the Royal society in London and continued his studies until his death in 1723 at the age of 91.



**Fig. 1-2.** Anton Van Leeuwenhoek's drawings of bacteria published in 1684 that he called "animalcules"

Nine of the estimated 500 Leeuwenhoek's microscopes and all of his drawings are still existing. Leeuwenhoek made microscopes that had a magnification of 266 x. However from the details of his drawings and sketches it is shown that he must have made considerably more powerful microscopes that have been lost.



Fig. 1-3. Anton von Leeuwenhoek



Fig.1-4. Louis Pasteur

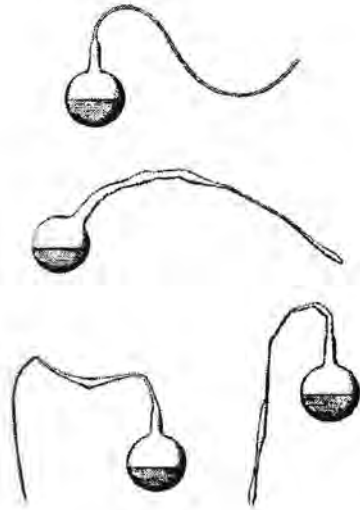


Fig. 1-5. Drawings of Pasteur's swan neck flask used in spontaneous generations experiment.

Louis Pasteur (1822-1895), a Professor of Chemistry in France, through his famous swan neck flask experiments disproved the

theory of abiogenesis. He boiled the nutrient solution in flask with a long narrow swan neck opening and unfiltered or untreated air could pass into the flask. The germs settled in the swan neck and hence no microbes appeared. He also filtered the air through cotton plug and dropped it in nutrient solution and found that micro organisms similar to those in air appeared. Hence he concluded that air contained the microbes that contaminated the boiled infusions. Pasteur's experiment disproved the spontaneous generation theory once for all. John Tyndall showed (1820-1893) that dust contained the germs and if no dust was present, sterile broth remained without microbial growth for a long time. Ultimately the theory of abiogenesis was discarded for microbes as well and Biogenesis was accepted. Cogniard Latour observed budding in yeast cell demonstrating that cells arise from preexisting cells.

### Cell theory:

Until the knowledge of microorganisms, cells of plants and animals accumulated and it was thought that a plant or an animal was entirely as a single unit. Rubert Hook(1665) coined the word cell(L.cella – a small enclosure) when he observed the hollow shells in cork. However the credit of proposing cell theory goes to Mathias Schleiden(Botanist) and Theodore Schwann(Zoologist) who independently recognized that cells constitute unicellular and multicellular forms of life. Cell theory states that all living organisms are cells or composed of cells, that all cells are basically similar in structure, function and composition and capable of autonomous growth and multiplication. The activity of an organism is the sum total of function of all cell comprising it. Cell is the smallest living unit capable of reproduction utilizing the food substances that are chemically different. In unicellular forms like bacteria, yeast and amoeba a single cell itself is an organism. On the other hand in multicellular plants and animals cells aggregate and from different types of tissues that make up the plant or animal. Even in different tissues the size and shape may vary but all cells have a cell wall or membrane, cytoplasm, nucleus and function in organized way. The epidermal cell in a leaf, palisade parenchyma and cortical cells may differ in size etc. but they are all basically similar in structure function and composition.

### **Microbes in Fermentation:**

Louis Pasteur found fermentation of fruits and grains resulting in alcohol production was due to microbes. He examined several batches of ferment and found different sorts of microbes with predominance of one type in good ferments and another kind in poor ones. Pasteur suggested proper selection of the microbe namely the yeast to get an uniformly good product and to heat the fruit juice to destroy the undesirable microbes without affecting the flavour of fruit juice. He demonstrated that holding the fruit juice at a temperature of 62.8<sup>0</sup>C(145<sup>0</sup>F) for an hour eliminated the undesirable microbes.

This process is named after him as Pasteurization, which is now employed in wineries and milk industry. **Pasteurization** is heating a liquid food or beverage to a controlled temperature to remove harmful and undesirable microorganisms and to enhance the quality. He solved the problem of contamination of wild yeasts an undesirable micro flora in wine industry.

### **Microbes and diseases:**

The fact that bacteria are the causative agent of some diseases was experimentally proved by Pasteur. As Pasteur solved the problem of wine industry in France, the French Government requested him to investigate the **pebrine** disease of silkworm. After struggle for several years he isolated the causative agent of pebrine, a protozoan parasite of silkworm. He suggested that the disease could be eliminated by using only healthy, disease free silk worms.

A disease called “Wool sorters” disease was common among people who worked with sheep and wool. This was also called as anthrax disease which affected cattle, sheep and sometimes man. Pasteur isolated the bacterium *Bacillus anthracis* from the blood of animals that had died out of this disease and grew them in laboratory. At the same time in Germany **Robert Koch**(1843-1910), a physician discovered the bacilli in the blood of cattle died out of anthrax. He isolated the organism, grew it in the laboratory and made sure that only one kind of bacteria was present (pure culture). He injected this bacterium to other healthy animals and produced the disease artificially.

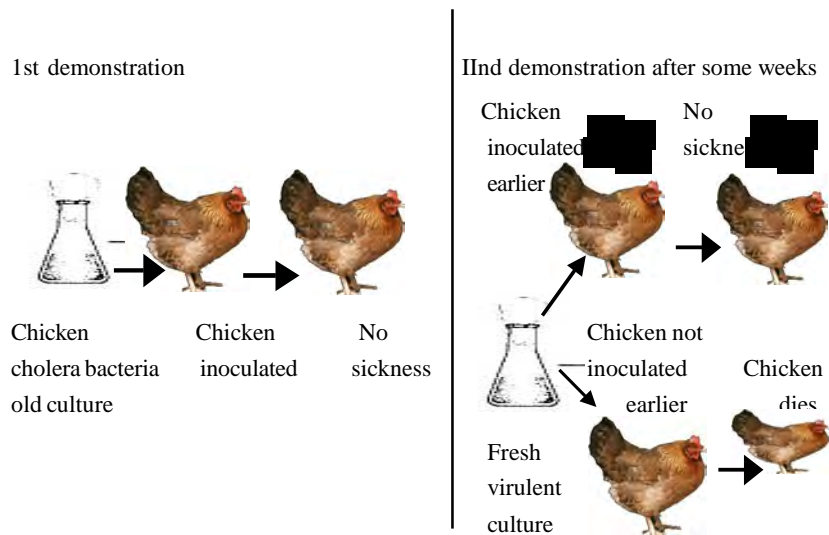
He reisolated the bacterium from the blood of experimentally infected animals which was similar to the ones originally isolated. These experiments led to the development of Koch’s postulates which is followed even to-day with a newly isolated pathogen to establish its pathogenicity. Robert Koch developed smear preparation and staining with dyes to increase clear observation under microscope. He also developed solid media using gelatin first and subsequently agar to obtain isolated colonies in culture plates. He discovered the bacteria causing pulmonary tuberculosis.

Pasteur was continuing his work on infectious diseases and isolated the chicken cholera bacterium in pure culture. He arranged for a public demonstration to prove his success and inoculated healthy chicken with the pure culture. But the chicken failed to develop sickness. Tracing the events of his experiment Pasteur found that he had accidentally used cultures several weeks old and not the fresh culture. He repeated the experiments after sometime and inoculated a fresh culture to newer fresh healthy chicken and also to the chicken inoculated in the previous demonstration.

He found that the chicken used for fresh culture were sick and died while the chicken which were inoculated previously with old cultures and again with fresh cultures failed to develop sickness and survived. Pasteur explained that old cultures which he used in the demonstration lost their virulence and the ability to produce the disease. After growing old the bacteria might have lost virulence which Pasteur designated as **attenuated** bacteria.

But these attenuated organisms do not cause disease but stimulate the host to produce antibodies that act against invading virulent organisms. **Edward Jenner**(1798) used cow pox virus to immunize people against small pox was similar to this demonstration. Pasteur used attenuated culture, which he called as vaccines(L.vacca=cow) to prevent anthrax.

Pasteur was assigned the task of developing a vaccine for **rabies** (hydrophobia) a fatal disease of man caused by bites of mad dogs, cats and wolf.



**Fig. 1-6** Chicken cholera inoculation demonstration by Pasteur

Rabies is due to a virus too minute to be seen under microscopes available at his time and not grown in laboratory. Therefore he used the saliva of mad dogs to inject rabbits. The brain and spinal cord of artificially injected rabbits were removed, dried, powdered and suspended in glycerine. By injecting this preparation Pasteur immunized dogs against rabies. Pasteur treated a boy Joseph Meister bitten by a mad wolf in a similar way and saved him. Thus vaccine against rabies was developed. **Vaccines** are preparations that upon administration to an animal or man induce active immunity against diseases. This process of immunization is called vaccination. Vaccines may contain killed cells or attenuated organisms or their components or products of a microorganism causing a disease. Antitetanus serum (ATS) and Tetanus toxoid are used against tetanus.

Joseph Lister (1827 – 1912), a young British surgeon gave indirect evidence that microorganisms were responsible for wound infection. Following the work of Pasteur on the involvement of microorganisms on fermentation and Putrefaction Lister developed a system of

antiseptic surgery designed to prevent microorganisms from entering wounds. He reasoned that surgical sepsis might be the result of microbial infection of the tissues exposed during operation. He developed methods for preventing the access of microorganisms to surgical wounds. On August 12, 1862 an 11 year old boy James Greenlees was brought to the Royal Infirmary where Joseph Lister was working as a surgeon. James was stroked by a Horse – drawn cart.

Lister splinted the broken bone and repeatedly dressed the wound in bandages soaked in phenol solution. Six weeks later the broken fragments of bone had become reunited by new growth and James was discharged from the hospital with sound health. This approach was successful and transformed the entire process of surgery. Lister sterilized the instruments by heat and sprayed diluted phenol over surgical area and prevented the microbial contamination.

Pasteur contributed significantly to the emergence of immunology with his work on vaccines for rabies and cholera. Along with Jenner and Pasteur the Russian Zoologist Elie Metchnikoff (1845 - 1916) was a pioneer in Immunology. It was believed in 1880's that the immunity was due to noncellular substances in the blood. Metchnikoff discovered that some blood leukocytes could engulf disease causing bacteria. He named those cells as phagocytes. The identification of phagocytes against invading microorganisms was the first step in immunology. Metchnikoff was awarded the Nobel prize in 1908 for his work on immunology and phagocytes.

**Winogradsky's contributions:**

The incomparable glitter of Pasteur's discoveries drawn Sergei Nikolaevitch Winogradsky to microbiology. This Russian microbiologist's techniques led to the isolation of useful bacteria and his enrichment culture technique was useful to understand environmental microbiology. The Winogradsky column developed by him is a miniature anaerobic ecosystem used for studying microbial communities.

Much of what we know about the biological cycling of sulfur and nitrogen come from Winogradsky's work.



## Antibiotics

The search for antibiotics began in late 1880's, with the acceptance of the germ theory of diseases. In the mid 1800 the Hungarian physician Ignatz Semmelweis and the English physician Joseph Lister developed some of the first microbial control practices. When the body's normal defenses cannot prevent or overcome a disease, it is often treated with chemotherapy. Antimicrobial drugs act by interfering with the growth of microorganisms. Moreover, it has to act within the host. Therefore, their effects on the cells and tissues of the host are important.

The ideal antimicrobial drugs kill the harmful microorganisms without damaging the host. The mechanism of inhibition is called antibiosis and from this word comes the term Antibiotic, a substance produced by some microorganisms. Some drugs have a narrow spectrum of microbial activity and some affect a broad range of gram positive and gram negative bacteria and are called broad spectrum antibiotics. Antimicrobial drugs are either bactericidal (kill the microbes directly) or bacteriostatic (prevents microbes from growing).

In the early 1929, Alexander Fleming, a British scientist, serendipitously discovered penicillin. During 1939, Howard Flory, Ernst Chain, and Norman Heatley obtained the *Penicillium* fungus from Fleming and overcame the technical difficulties and produced the drug in crude form. By 1946, the drug had become wide spread for clinical use.

In 1943, Selman Walksman and his group discovered another antibiotic Streptomycin from *Streptomyces griseus*. The streptomycin proved effective against several common infections.

The antibiotics may affect the cell wall synthesis, inhibit protein synthesis, make injury to plasma membrane, inhibit nucleic acid synthesis and inhibit the synthesis of essential metabolites. The commonly used antibiotics include Streptomycin, Neomycin, Ampicillin, Tetracycline, Chloramphenicol, Bacitracin, Erythromycin, etc.

## Points to Remember

1. Early men out of superstition, ignorance and due to the fear surrounding the life, believed that living organisms were created by God. It was also believed that animals originated spontaneously from soil, plants or other unlike animals. There were more discussions about the spontaneous generation theory among scientists.
2. Anton van veluwen hock made glass lenses by grinding and mounting them into brass centraptions and he called them as microscopes. He observed a number of microorganisms and called them animalcules.
3. Louis Pasteur disproved the theory of spontaneous generation theory by his swan neck flask experiments.
4. Cells constitute unicellular and multicellular forms of life. Cell theory states that all living organisms are cells or composed of cells, that all cells are basically similar in structure, function and composition and capable or autononous growth and function.
5. Louis Pasteur introduced pasteurization a process which is used in wine industry and dairy.
6. Joseph Lister introduced disinfection and sterilized the instruments by heat and sprayed diluted phenol over surgical area and prevented the microbial contamination.
7. In 1929 Alexander Fleming discovered penicillin. In 1943 Selman Walksman discovered streptomycin. After the discovery of antibiotics many diseases were treated effectively.

## Chapter - 2

### MICROSCOPY

The Microscope used by van Leeuwenhoek during the seventeenth century was a simple microscope and had only one lens and is equivalent to a magnifying glass. Later a Compound Microscope was built by Robert Hooke. However, the credit of making a compound microscope goes to Zaccharias, a Dutch spectacle maker around 1600. The early compound microscopes were of poor quality and could not be used to see bacteria. Around 1830, a better Microscope was developed by Joseph Jackson Lister (Father of Joseph Lister). Modification and improvements to Lister's microscope resulted in the development of modern compound microscope.

Microbiologists use a variety of light microscopes for their work, which include:

1. Bright field Microscope
2. Dark field Microscope
3. Phase Contrast Microscope
4. Fluorescence Microscope.
5. Electron Microscope

#### Dark - field Microscope:

A dark-field Microscope is used for examining live microorganisms which are either invisible in the ordinary light microscope, cannot be stained by standard methods or are so distorted by staining that their characteristics cannot be identified.

The condenser in dark field microscope contains an opaque disc. The disc blocks light that enters the objective lens directly. The light that is reflected off the specimen enters the objective lens. Since there is no direct background of light, the specimen appears light against a dark background, hence the name dark - field Microscope (Fig).

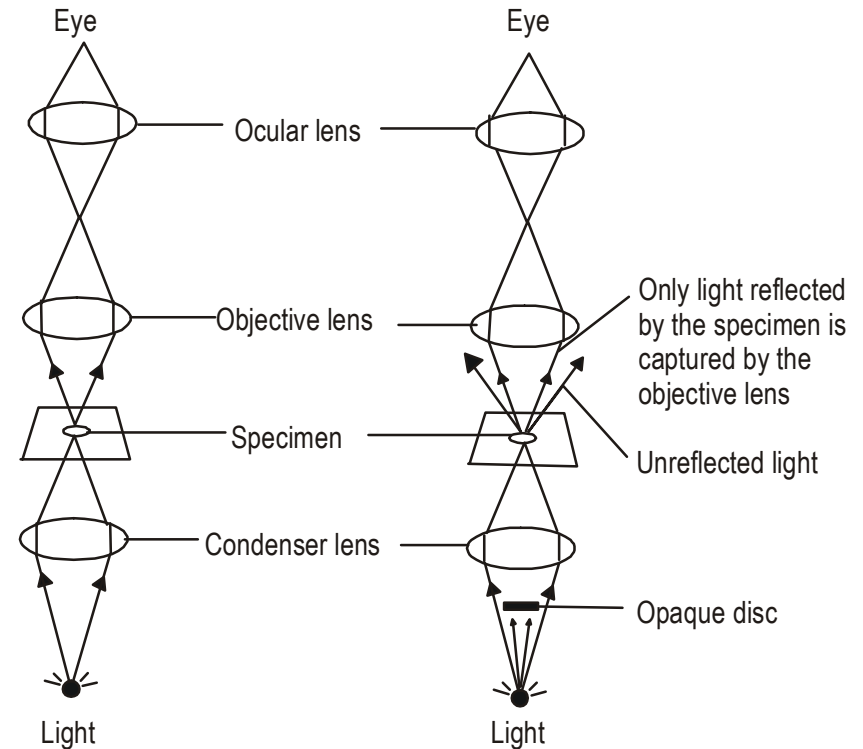


Fig. 2-1. Comparison of Light Pathways of bright field and dark field Microscopy.

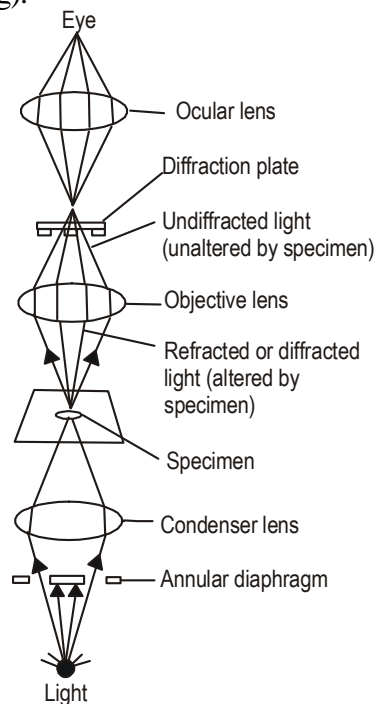
Dark - field Microscope is used to identify very thin, unstained microorganisms, such as the spirochete, *Treponema pallidum*, the causative agent of syphilis.

#### Phase Contrast Microscope:

Phase contrast Microscope first described in 1934 by Dutch Physicist Frits Zernike, is a contrast - enhancing optical technique that can be utilized to produce high - contrast images of transparent specimens.

The complete detail of living cells is undetectable in bright field microscope because there is too little contrast between structures with similar transparency. Such organisms are observed with a phase contrast microscope. The Phase Contrast Microscope is widely used for observing biological specimens. Phase Contrast Microscope is a type of light microscope, which enhances the contrasts of transparent and colorless objects by influencing the optical path of light. In phase contrast microscope, the light passing through a transparent part of the specimen travels slower.

The condenser of a phase contrast microscope has an annular stop, an opaque disk with a thin transparent ring, which produces a hollow cone of light (fig).



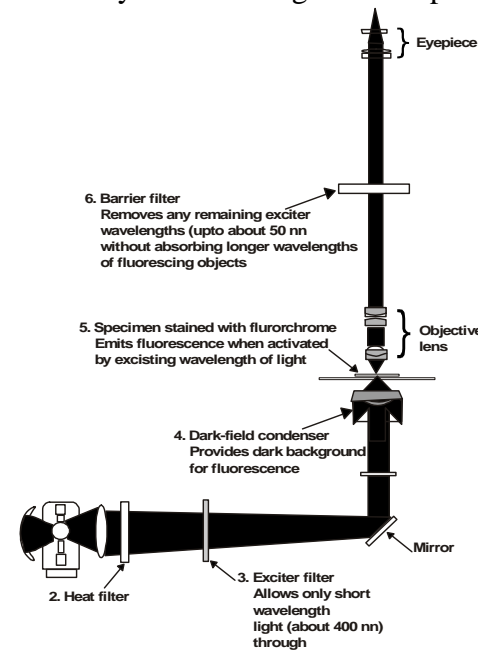
**Fig. 2-2.** The light pathway of Phase Contrast Microscopy

When this cone of light passes through a cell, some light rays are bent due to density variation and refractive index within the

specimen. The deviated light is focussed to form an image of the object. Undeviated light rays strike a phase ring in the phase plate, located in the objective. So in phase contrast microscope one set of light rays comes directly from the light source, the other set of light comes from the reflected or diffracted from the particular structure of the specimen. When two set of light rays are brought together they form an image of the specimen on the ocular lens, containing areas that are relating light (phase) through the shades of gray to black. The internal structure of the specimen becomes more sharply defined in phase contrast microscopy.

**Fluorescence Microscope:**

Fluorescence microscope is so designed that the specimen can be illuminated at one wavelength of light and observed by a light emitted at a different wavelength (figure). Some organisms exhibit fluorescence naturally under UV light. If the specimen.



**Fig. 2-3.** Fluorescence Microscopy - Illustration of Principle of Light pathway

does not have natural fluorescence and it has to be stained with a fluorescent dye called fluorochromes. When microorganisms are stained

with fluorochrome and observed under fluorescence microscope with an UV or near UV source. They appear as luminescent, bright objects against a dark background.

The Fluorescence Microscope exposes a specimen to UV violet or blue light and forms an image of the object with resulting fluorescent light. A mercury vapour arc lamp produces an intense beam and heat transfer is emitted by a special infrared filter. The light passes through an excited filter, which transmits only the required wavelength. A dark field condenser provides a black background against which the fluorescent object glows.

The microscope forms an image of the fluorochrome stained microorganism from the light emitted when they fluoresce. The barrier filter positioned after the objective lens removes the remaining UV light that may damage the eyes or blue and violet light, which will reduce the image contrast.

The fluorescent microscope is used in medical microbiology to observe pathogens such as *Mycobacterium tuberculosis*. In microbial ecology the fluorescence microscope is used to observe microorganisms after staining the sample with the fluorochrome acridine orange dye. The stained organisms with fluorescent orange or green can be detected among other particulate matter.

### Electron Microscope:

Light Microscopes are limited by the physics of light to 500x to 1000x magnification and a resolution of 0.2 micrometers. This limitation made the development of Electron Microscopy. Thus, the theoretical limit was reached in the early 1930s and there was a scientific urge to observe the ultrastructure and the fine structure of cells.

To observe the fine structure there is a need for 10,000 x plus magnification, which is not possible by Light Microscopy. The Electron Microscope was developed in 1931 in Germany by Max knoll and Ernst Ruska. The first scanning electron microscope was introduced in 1942 and the Electron Microscopes were made available commercially around 1965.

Electron Microscope works similar to that of light microscopes except that they use a focussed beam of electrons instead of light to 'image' the specimen

The following basic steps are involved in Electron Microscopes.

1. A beam of electron is formed from an electron source and accelerated towards the specimen using a positive electrical potential.

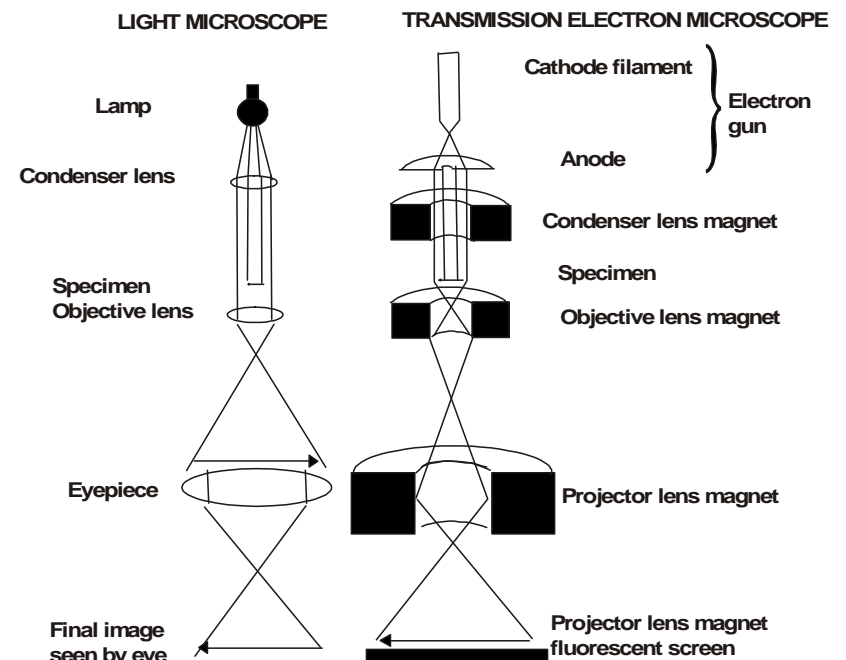


Fig. 2-4. Illustrated Light pathway Comparison of Light Microscope and Transmission Electron Microscopy

2. The beam is confined and focussed using metal apertures and magnetic lenses into a thin, focussed monochromatic beam.

3. The beam is focussed on to the sample using a magnetic lens.
4. Interactions occur inside the irradiated sample, affecting the electron beam. These interactions and effects are detected and transformed into an image.

There are two type of Electron Microscopes. They are

1. Transmission Electron Microscope
2. Scanning Electron Microscope

### 1. Transmission Electron Microscope:

The Transmission Electron Microscope is a complex and highly advanced microscope (fig). The Electron gun contains a tungsten filament which when heated generates a beam of electrons that is then focussed on the specimen by the condenser.

Electrons cannot pass through the glass lens, hence a doughnut-shaped electromagnets called magnetic lenses are used to focus the beam. The electrons will be deflected by collisions with air molecules. So, the column containing the lenses and specimen is under high vacuum to obtain a clear image of the specimen on a fluorescent screen. The denser region in the specimen scatters more electrons and appears darker in the image because lesser electrons strike that area of the screen whereas electron transparent regions are brighter. The image captured at the screen can be made permanent on a photographic film.

Transmission electron microscopy has high resolution and extremely useful to observe different layers of specimens; however Transmission Electron Microscope has some disadvantages. Since electrons have limited penetrating power, only very thin section of the specimen (about 100nm) can be studied effectively. There is no three dimensional view. In addition specimens must be fixed, dehydrated and viewed under a high vacuum to prevent electron scattering. The procedure used for specimen preparation, for viewing under Transmission Electron Microscope causes some shrinkage and distortion.

### Scanning Electron Microscope (SEM)

Scanning Electron Microscope is used to examine the surfaces of microorganisms. Scanning Electron Microscope provides a three dimensional view of the specimen. The electron gun produces a finely focussed beam of electrons called the primary electron beam. These electrons pass through electromagnetic lenses and are directed over the surface of the specimen (fig).

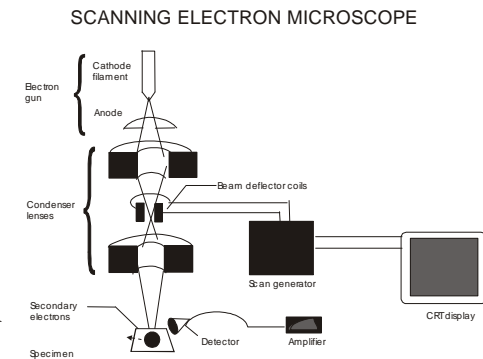


Fig. 2-5. Illustrated Light pathway of Scanning Electron Microscopy

The primary electron beam blocks electrons on the surface of specimen, and the secondary electrons thus produced are transmitted to an electron collector, amplified and used to produce image on a viewing screen or photographic plate. The image is called a Scanning Electron Micrograph.

### Points to remember

1. With the help of dark field microscope movement of the organisms and the organisms that can not be seen under bright field microscope can be seen.
2. Phase contrast microscope is useful in seeing the living cells and their contents without staining them.
3. Fluorescence microscope is useful for direct demonstration and immunological demonstration of organisms and antigen and antibody.
4. Electron microscope can magnify the objects million times, and one can see whole cellular structures.

## Chapter - 3

### CONTROL OF MICROORGANISMS

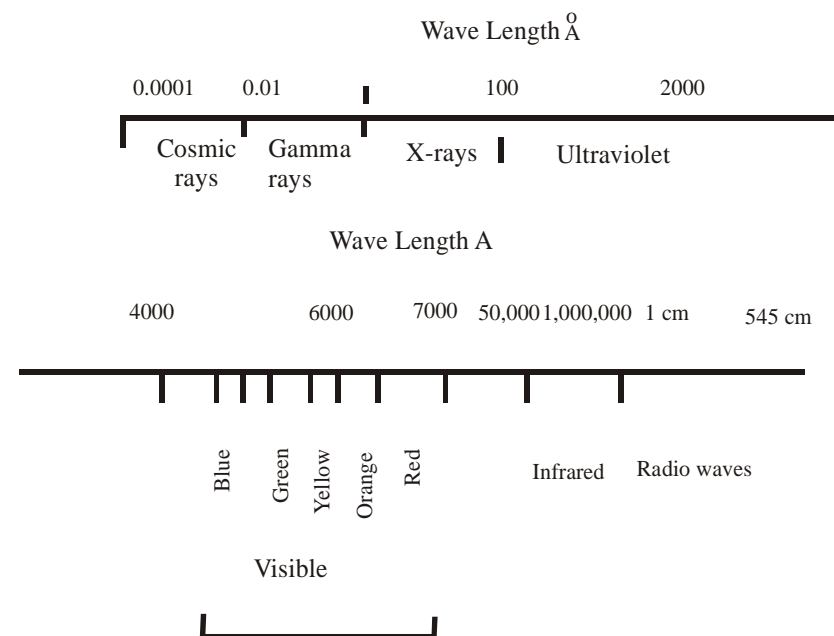
Microorganisms, both beneficial and harmful are present everywhere. Man prefers to culture the beneficial ones and at the same time wants to control the growth of undesirable, harmful, pathogenic ones. Even in culturing an useful microbe, contamination by another useful organism has to be controlled as the latter becomes a contaminant. This microbial control becomes necessary to prevent transmission of diseases, contamination, deterioration of materials used and spoilage of food. In contrast to sterilization which completely removes or kills the microorganisms control is aimed in the reduction in total microflora or microbial activity.

Microorganisms may be controlled by removal, inhibition or killing by physical or chemical agents. The physical agents include dry heat, steam (moist heat), flame (incineration), radiation, filtration etc. Antiseptics, disinfectants, detergents, alcohol and heavy metals are certain chemical agents used. The removal of microorganisms is accomplished by filtration and ultra centrifugation. The inhibition is keeping the cell in a static condition without allowing it to grow and multiply using antimicrobial agents. Killing or death is an irreversible loss of ability to reproduce by heat, radiation or chemicals.

#### Radiation:

Radiation is energy transmitted through space. Solar radiation gives the light energy for photosynthesis and the heat generated enables drying and desiccation of materials and thereby control the microbes to certain extent. **Electromagnetic radiation** comprising of light rays (visible light), x-rays, UV rays, gamma rays, etc. is the most important in control of organisms. Radiation is described by its wavelength ( $\lambda$ ) and measured in Angstrom ( $\text{\AA}$ ) units ( $1 \mu\text{m} = 10,000 \text{\AA}$ ;  $1 \text{nm} = 10 \text{\AA}$ ) and its energy in electron voltas (ev). The electromagnetic spectrum is illustrated in fig.1.

Radiation with more than 10ev energy like **gamma rays and X-rays** ionize the molecules (ionizing radiation) by driving out electrons. When irradiated with these rays cells release free hydrogen radical, hydroxyl radical and peroxides that cause intracellular damage in a variety of materials and hence non-specific in their effect. This also produces less heat in the irradiated material and hence called **cold sterilization**. This has application in sterilization of heat sensitive substances and in food and pharmaceutical products. X-rays are lethal to all forms of life because of their penetrating ability. But their use in microbial control is limited because of its high production cost and difficulty in use as they are given off on all directions from its source.. But these rays are widely used to develop microbial mutants.



**Fig.3-1.** Electromagnetic spectrum of radiant energy

Ultra Violet (UV) radiation includes rays of 150 to 3900 Å wave length, but UV rays of wave length around 2650 Å possess the

highest bactericidal property. Most UV lamps (germicidal lamps) emit UV rays of 2600 to 2700 Å and are used in microbiological laboratories, hospital operating rooms, aseptic filling rooms, in pharmaceutical industry where sterile materials are filled in vials and in food and dairy industries to control microbes on surfaces. UV rays have less energy, very little penetrating power and do not cause ionization (non-ionizing radiation) but absorbed. Microorganisms on surfaces directly exposed to UV rays alone are destroyed as a large portion of these rays are filtered even by a thin glass. The UV light is also present in solar radiation (sun light) but most of the shorter wavelength UV rays get filtered by clouds and smoke of atmosphere and only rays of 2670-3500 Å wave length reach the earth's surface. This explains the limited degree of germicidal effect of sunlight.

### **Chemical Agents:**

Antimicrobial chemical agents are many and a variety of chemicals inhibit the growth and metabolism of the organism or kill them. Some of these agents are used as antiseptics and some others are used as disinfectants.

**Antiseptic agent** is a substance that prevents growth/or activity of microbes either by destroying them or by inhibiting the growth and metabolism (Antisepsis X sepsis). The term is used for substances that is applied on body like ethyl alcohol, spirit, tincture iodine, hexylresorcinols.

**Disinfectants** are chemicals that kill the growing forms of pathogens but do not kill resistant spore forms. Disinfection destroys infectious agents. These chemicals are applied on inanimate objects like floor and work benches. Phenols, mercuric chloride, hypochlorites, chloramines etc. are disinfectants. In certain cases like phenol and hypochlorites a low concentration is used to disinfect the wounds on living organisms and a higher concentration to disinfect inanimate surfaces. The former is like antiseptic agent while the latter is a true disinfectant.

Depending upon the type of usage and their effectiveness against different microorganisms the chemicals that control microorganisms are

also designated as Santizer, Germicide (Microbicide), Bactericide, Bacteriostatic etc. Sanitizing agent (Sanitizer) reduces the microbial population to safe levels as per the public health standard. These are mostly employed in daily care utensils, in dairies and food industries. **Germicide** is an agent that kills the growing forms and not the resistant spore forms of germs. **Bactericide** is an agent that kills bacteria (Bactericidal agent). Fungicides kill fungi. Virucide, sporicide are agents that kill viruses and spores respectively. An agent that prevents the growth of bacteria (without killing) is called **Bacteriostatic**. **Fungistatic** agent stops the growth of fungi.

### **Phenols:**

In the 19<sup>th</sup> century, prior to the discovery of disinfectants and antibiotics death due to post operative wound infection was very common. Joseph Lister, English Physician, for the first time used **dilute solutions of carbolic acid (Phenol)** which killed bacteria and he used to soak surgical dressings. Wounds treated with such materials healed quickly. He applied phenol solution to surgical incision and wounds to prevent infection and sprayed phenol in operating room to control infection. The credit of introducing antiseptic agents goes to Joseph Lister. Antimicrobial action of any compound is evaluated using phenol as standard and the process is called phenol-coefficient technique. Phenol, cresol, phenyl pheno, hexyl resorcinol are some phenolic compounds used as disinfectants. Aqueous solutions of 2 to 5% phenol is used to disinfect sputum, urine, feces, contaminated utensils etc. Diluted phenol is used in detergents to enhance disinfection property. Hexylresorcinol, a strong surface tension reductant, as a solution in glycerine is used as antiseptic. The antimicrobial action of phenolic compounds is due to disruption of cells and leakage, precipitation of cell proteins and inactivation of enzymes. The lethal effect is due to damage to the membrane structures.

### **Alcohols:**

Alcohols in general have germicidal property with an increase in germicidal action with the increase in molecular weight. Ethyl alcohol is mostly used. Methyl alcohol is less bactericidal and poisonous.

Except propyl alcohol the higher alcohols like butyl, amyl etc are not used because of their immiscibility with water. Ethyl alcohol (Ethanol) between 50 and 90% is effective against vegetative and non spore forming cells but 70% is more common in use. Ethanol (70%) is used in surface sterilization in laboratory, as antiseptic agent on skin before injection and also for disinfection of oral thermometers. Alcohol concentration of 60% and above is effective against viruses too.

The antimicrobial action of alcohol is due to its denaturation of proteins, solubilization of lipids of cell membrane and by dehydration of cells. Absolute alcohol (free from water) is ineffective against dry cells because of its poor penetrating ability than its aqueous solutions.

### Heavy metals

The heavy metals like **mercury, silver and copper** and their salts are effective anti microbial agents. Mercuric chloride (bichloride of mercury) at 0.1% concentration is used as a surface sterilizing agent in laboratory. Because of its corrosive action on metals and toxicity to animals its use is limited. Organic compounds like mercurochrome, merthiolate are less toxic and therefore used as antiseptics on cutaneous and mucosal surfaces.

The practice of treating the eyes of new born babies with a few drops of 0.1% silver nitrate to prevent the gonococcal infection of eyes is well known. Silver nitrate at 0.1% is bactericidal to most organisms and it is widely used. A colloidal solution consisting of a protein with metallic silver or silver oxide is also used as antiseptic. The Bordeaux mixture, the first known fungicide developed to combat downy mildew of grapes is a mixture of copper sulphate and lime. Even today copper fungicides like copper oxychloride are available in market. Copper sulphate is more effective against algae, fungi and bacteria. It is used at 2ppm levels to control algae in swimming pool.

The antimicrobial activity of heavy metals is due to their combination with proteins and their inactivation. At high concentrations they coagulate cytoplasmic proteins resulting in damage or death of cells. Mercury reacts with sulphhydryl groups of enzymes and inactivates them. To be effective as disinfectants they have to be used after cleaning the

organic matter as its presence reduces their action. Copper is toxic at high concentration. It is to be noted here that copper although toxic is required in traces for the function of certain copper containing enzymes. The lethal effect by certain metals at very small amounts on bacteria is known as **oligodynamic action**.

### Halogens:

Among the halogens fluorine, chlorine, bromine, iodine and astatine, **chlorine and iodine** are widely used as antiseptics and disinfectants. Chlorine in the form of compressed gas (in liquid form) is used in purification of municipal water. Safe handling of gas is difficult and requires equipments and therefore chlorine compounds are preferred for practical use. The traditional practice of application of bleaching powder to well water in cholera prone areas, in toilets and in unhygienic places provides the chlorine that kills microorganisms. Hypochlorites like calcium hypochlorite  $\text{Ca}(\text{OCl})_2$  also known as chlorinated lime and sodium hypochlorite ( $\text{NaOCl}$ ) and chloramines like chloramine-T and azochloramides are used as disinfectants, antiseptics and as sanitizing agents.

Semmelweis, a Hungarian, used hypochlorites as antiseptics in obstetrical practice to reduce the incidence of childhood fever. Washing hands in hypochlorite solution prevented the spread of infection after examining the patients. Chlorine compounds are used to disinfect wounds and treat athlete's foot. Sodium hypochlorite of 1% concentration is used for personal hygiene and 5-12% is used as household bleaches, disinfectants and sanitizing dairy and food processing equipments. The concentration of hypochlorite used should provide at least 1ppm of residual chlorine.

The mode of action of chlorine and its compounds is through formation of antimicrobial hypochlorous acid ( $\text{HClO}$ ) when chlorine is added to water or formed due to hydrolysis of hypochlorites and chloramines. The nascent oxygen released upon decomposition of hypochlorous acid oxidizes cellular components destroying the cells. The direct action of chlorine with proteins of cell membrane and enzymes also has a killing effect.



Iodine, the oldest germicidal agent is used in the form of tincture iodine a 2% iodine in 2% sodium iodide diluted in alcohol is used, as iodine is readily soluble in alcohol and aqueous solution of potassium iodide as it is only slightly soluble in water. Iodophores, (e.g. Polyvinylpyrrolidone) mixtures of iodine and surface active agents that act as carriers and solubilizers for the iodine are also used as germicides. These are non staining unlike iodine and have low irritant properties than tincture iodine.

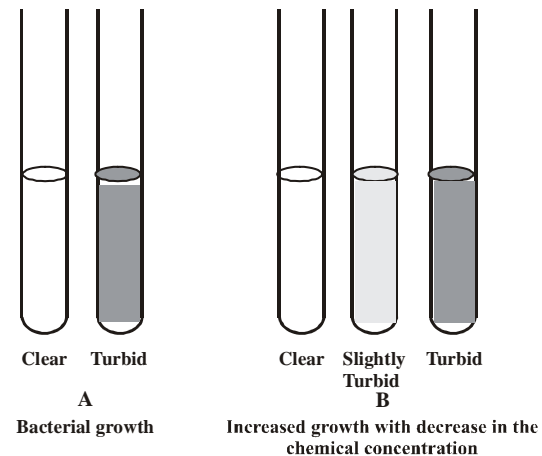
Iodine is bactericidal effective against all kinds of bacteria, sporicidal, fungicidal and to some extent virucidal. Its solutions are used as disinfectant on skin. It is also used for disinfection of water, air and sanitization of utensils. The antimicrobial action is due to its strong oxidizing power, inactivating proteins with sulfhydryl group and halogenation of tyrosine units of enzymes and cellular proteins.

Apart from the chemical agents described above there are several antimicrobial agents used in day to day use in different places. Triphenylmethane dyes like malachite green and crystal violet are used in media to inhibit Gram positive bacteria. Acridine dyes like acriflavine and tryptoflavin inhibit staphylococci and gonococci and are used in the treatment of burns and wounds prior to antibiotic discovery. Detergents like soap used for cleaning surfaces act by wetting or depressing surface tension. Quaternary ammonium salts (Cetrimide, Ceepryn etc) are used in detergents and also as disinfectants, sanitizing agent, used on skin, as a preservative in ophthalmic solutions and in cosmetic preparation.

Aldehydes (formaldehyde and glutaraldehyde) are microbicidal and sporicidal. Formaldehyde (Formalin) is used to sterilize closed area and vapourizes at room temperature and acts in gaseous form. Glutaraldehyde is used in sterilizing urological instruments, lensed instruments and respiratory therapy equipments. There are certain gaseous agents like Ethylene oxide and  $\beta$ -propiolactone. Ethylene oxide is an effective sterilizing agent for heat and moisture sensitive materials. Spices like pepper, biological preparations, soil, plastic, syringes, tongs, blood transfusion apparatus and catheterization equipments are sterilized by ethylene oxide fumigation.

### Evaluation of antimicrobial action:

The chemical agent is tested against a specified microorganism (test organism) in **Tube-Dilution** and **Agar-plate Techniques** and the decrease in the growth, or complete absence of growth is recorded. Water soluble liquid substances are diluted and dispensed into sterile tubes. A measured quantity of test organism is inoculated and at intervals, a transfer is made from this tube to other tubes containing sterile media.



**Fig. 3-2.** Laboratory evaluation of antimicrobial agent

These tubes are incubated and the appearance of growth is observed. By performing a plate count at specified intervals the number of organisms killed per unit time can also be determined by this method.

The chemical agent can also be tested by incorporating it into an agar medium or broth to which the test organism is inoculated. The decrease in the growth or absence of growth shall be assessed after a period of incubation. Broth or agar medium without the chemical agent and inoculated with the organism will serve as a standard for comparison. The inhibition by a chemical can be assessed by placing the chemical agent in agar medium inoculated with the test organism. After incubation the plate is observed for inhibition zone. Usually a solution of the test chemical is impregnated into absorbent(filter) paper or poured in hollow cylinders or in agar wells cut by means of a sterile cork borer. Gaseous substances are evaluated by exposing paper strips impreg-

nated with bacterial spores under specific conditions and then assessing the survivors after exposure.

**Table-1:** An example of phenol coefficient method of testing a disinfectant with *Staphylococcus aureus*

Dilution		Subculture tubes		
		5 min.	10min	15min
Disinfectant (D)	1:50	0	0	0
	1:100	+	0	0
	1:150	+	+	0
	1:200	+	+	+
Phenol	1:50	0	0	0
	1:60	+	0	0
	1:70	+	+	0
	1:80	+	+	+
Phenol-coefficient of D	$\frac{100}{60}:1.66$	-	-	-

**Phenol-coefficient method** is a tube –dilution technique universally followed official test. Phenol-coefficient is defined as the ratio between the greatest dilution of the disinfectant killing the test organism in 10 min and not in 5 min to the greatest dilution of phenol killing the test organism in 10 min and not in 5 min. As phenol is used as standard for comparison this is known as phenol-coefficient method and is suitable for testing disinfectants miscible with water and have antimicrobial action similar to phenol. A series of dilution of the disinfectant tested is prepared and dispensed in 5ml quantities in test tubes to which 0.5ml of 24h old broth culture of the test organism either *Salmonella typhi* or *Staphylococcus aureus* is inoculated. Simultaneously a series of dilutions of phenol is prepared and the same amount of inoculum is added. Both the set of tubes, those containing the disinfectant and the test organisms and phenol and the test organisms are placed in a water bath at 20°C. Subcultures are made with the inoculation needle into sterile tubes of medium at 5,10 and 15 min intervals, incubated and observed for growth. The highest dilution of the disinfectant tested killing the test organism in 10min and not in 5 min is

divided by the highest dilution of phenol showing similar result to determine the phenol coefficient. An example is given in Table.1 & Fig.1 This laboratory test provides reliable information about the practical application of disinfectants.

#### Points to remember

1. Radiation is transmission of energy through space
2. Ultraviolet radiation includes rays of wavelength ranging from 150-3900Å.
3. Ionizing radiation is due to gamma and X-rays. UV rays cause non-ionizing radiation.
4. Germicidal lamps emit UV rays of 2600 to 2700 Å wave length.
5. Solar radiation possesses UV rays but they are mostly filtered by the atmosphere.
6. Antiseptic agents are used over skin and wounds.
7. Disinfectants are used to kill growing forms of pathogens on inanimate objects
8. Joseph Lister was the first to use phenol as an antiseptic agent.
9. Alcohol denatures proteins and solubilizes lipids.
10. The antimicrobial activity of heavy metals is called oligodynamic action.
11. Copper sulphate is used as a fungicide, bactericide and an algicide.
12. Chlorine is used as a disinfectant in water purification.
13. Iodine is effective against all kinds of bacteria and spores.
14. Detergents contain antimicrobial compounds like quaternary ammonium bases.
15. Formalin denatures protein and acts in vapour phase.
16. Ethylene oxide is used to fumigate spices and biological preparations.
17. Mercuric chloride solutions are not used to disinfect metallic surfaces.
18. Phenol-coefficient method is used to evaluate the antimicrobial compound in comparison with phenol.

## Chapter - 4

### ENERGY AND ENZYMES

Any living organism, a bacterium, plant or animal, sustains on nutrients or food substances that serve as carbon and energy source. The work performed by a living organism depends on certain chemical reactions. All organized essential chemical changes that occur in a living cell (or organism) are collectively termed “**Metabolism**” (Gr: metabole=change). Metabolism comprises of catabolism and anabolism.

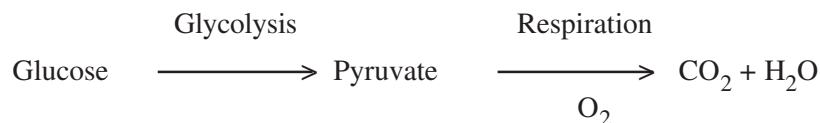
**Catabolism** is the breakdown of food that yields material for the synthesis of cell itself and the energy for cellular activity like motility, reproduction and for synthetic activities. This is an energy production process. **Anabolism** comprises of all the synthetic and cell building activities of the cell utilizing the energy liberated from the breakdown processes.

Catabolism and anabolism are continuous, simultaneous and linked processes in normally growing cells, the former constantly furnishing the necessary material and energy and the latter constantly replacing the worn out or used up constituents of cells by synthesis of new substance. Metabolism ceases permanently only with death. However, metabolism of many unicellular organisms can be stopped without loss of viability for many decades under conditions of lack of nutrients, freezing, drying, chemical microbiostasis or in dormant spores.

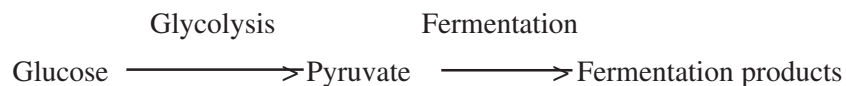
#### Glycolysis

Glycolysis, the splitting of sugar to derive energy is a type of catabolism of glucose widely occurring in microorganisms, plants and animals. As glycolysis does not require the presence of oxygen it operates in both aerobic and anaerobic cells.

#### Aerobic condition



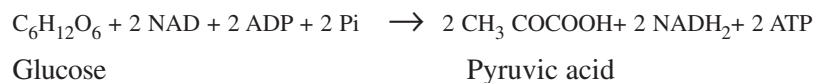
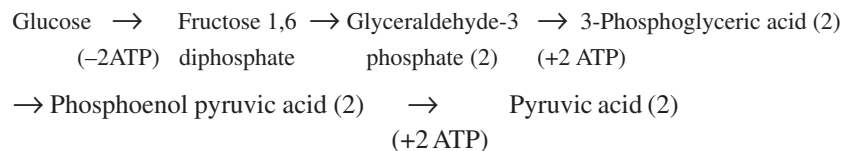
#### Anaerobic condition

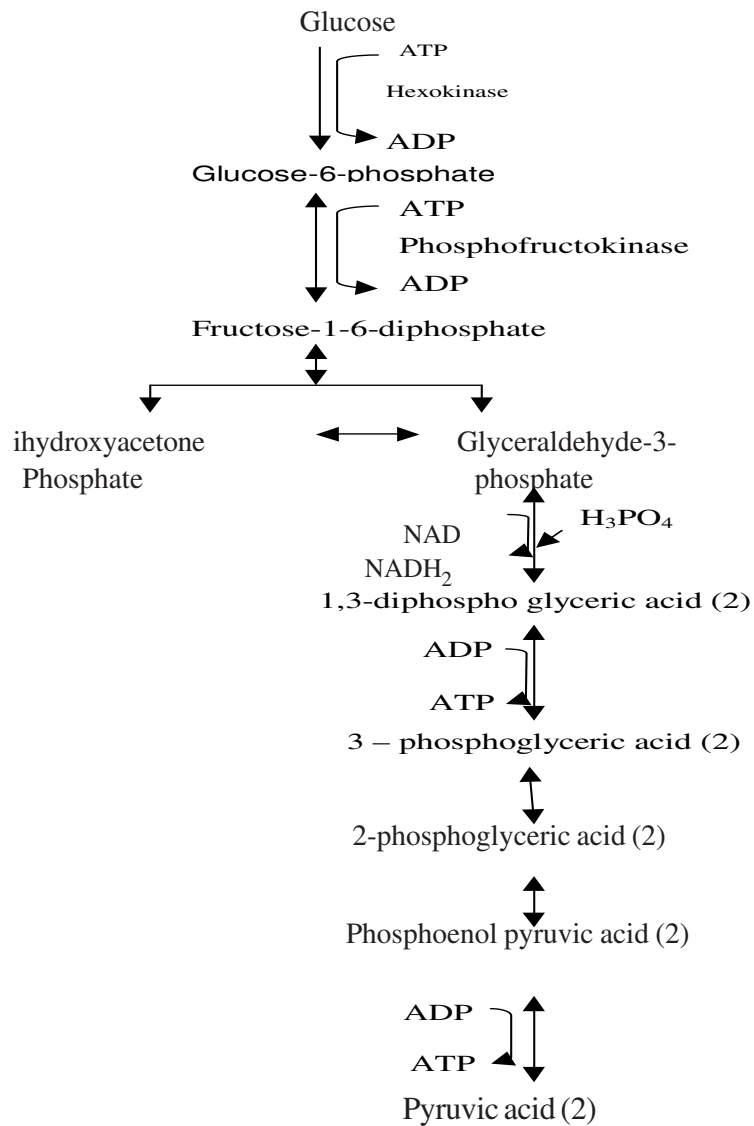


In glycolysis, the glucose is phosphorylated utilizing one Adenosine triphosphate (ATP) to form Glucose-6-phosphate which is converted to Fructose-6-phosphate then to Fructose 1,6-diphosphate utilizing another ATP molecule. Fructose 1,6-diphosphate, a six carbon compound is split into two – three carbon compounds viz., Dihydroxy acetone phosphate and Glyceraldehyde-3-phosphate.

These two compounds are in equilibrium but the tendency is to swing towards the latter. Glyceraldehyde-3-phosphate is oxidized to pyruvic acid through several intermediates. During this process two Adenosine diphosphate (ADP) molecules are converted to ATP molecules per molecule of Glyceraldehyde-3-phosphate oxidized.

As two Glyceraldehyde-3-phosphates (2 x 3 carbon) are formed per molecule of glucose (6 carbon), oxidized 4 ATP molecules are synthesised while 2 ATP molecules are utilised in the synthesis of Fructose 1,6-diphosphate from Glucose with a net yield of 2 ATP molecules. Hence the overall reaction in glycolysis is

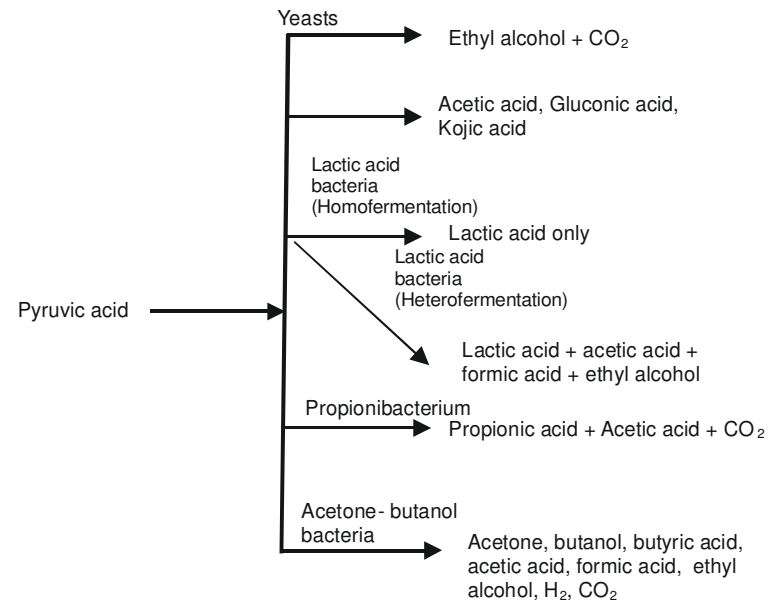




**Fig. 4-1.** Glycolytic pathway of glucose metabolism (also called Embden-Meyerhof pathway after its discoverer).

Another process of catabolism of glucose exists in both prokaryotic and eukaryotic cells enabling synthesis of pentose phosphates

and hence called **pentose phosphate pathway**. It involves some reactions of glycolysis pathway (shunt of glycolysis) and hence called as **Hexose monophosphate shunt**. Since phosphogluconic acid is an intermediate product it is also known as **phosphogluconate pathway**. This method of catabolism of glucose is not a major energy yielding process in most microorganisms but provides reducing power  $\text{NADPH}_2$  required for biosynthetic reactions and pentose phosphates like ribose phosphates for the nucleotide synthesis. It is also a process of obtaining energy from 5 carbon sugars. **Entner-Doudoroff pathway**, another process of glucose catabolism, is found in aerobic and anaerobic prokaryotes and not in eukaryotes is widespread among Gram-negative bacteria. The ultimate product is pyruvic acid which is catabolized through TCA cycle.



**Fig.4-2.** Metabolites formed from pyruvic acid

Pyruvic acid is the key intermediate for many of the metabolites formed by both aerobic and anaerobic organisms. In aerobic organisms pyruvic acid is completely oxidized to  $\text{CO}_2$  deriving its entire

energy through TCA cycle whereas in anaerobic organisms this is reduced to ethyl alcohol, lactic acid, acetic acid, butyl alcohol, etc.,.

### Fermentation

Fermentation is an energy yielding reaction in anaerobes occurring in the absence of oxygen. In fermentation industries any process employing microorganisms for commercial production of alcohol, acetone, vinegar, antibiotics, etc., is designated as fermentation regardless of whether the process is aerobic or anaerobic. But in scientific usage fermentations are energy yielding reactions occurring in anaerobes which use organic compounds as electron donors and acceptors. In other words oxygen (or other inorganic compounds) is not the terminal electron acceptor in fermentation. Souring of milk to curd is a fermentation process wherein lactose is converted to lactic acid. Rising of dough in bread and souring of idly batter are also fermentations. Similarly toddy tapped from the inflorescence of palmyrah and coconut palms where the sugary juice is converted to ethyl alcohol by naturally occurring yeast is a fermentation process. Alcohol production in distilleries from molasses, the sugar industry by product, employing yeast, is a typical fermentation process.

### The Tricarboxylic acid cycle

The **Tricarboxylic acid (TCA) cycle** is so named because of the formation of tricarboxylic acids like citric acid and isocitric acids. It is also known as **Sir Krebs's Citric acid cycle** after its discoverer Hans Krebs or as **citric acid cycle**. This cycle functions both like a catabolic (breakdown) and also as anabolic (synthesis) as the pyruvic acid is completely oxidized to  $\text{CO}_2$  (catabolic) through several intermediates that serve as precursors for the biosynthesis of amino acids, purines, pyrimidines etc.,. Since both catabolic and anabolic processes occur together in this cycle it is called **amphibolic cycle**. Further the sequence of reactions in this cycle generate energy in the form of ATP and reduced coenzymes molecules ( $\text{NADH}_2$  and  $\text{FADH}_2$ ) that are utilized in respiratory chain to generate ATP. This is the method of energy production by aerobic process.

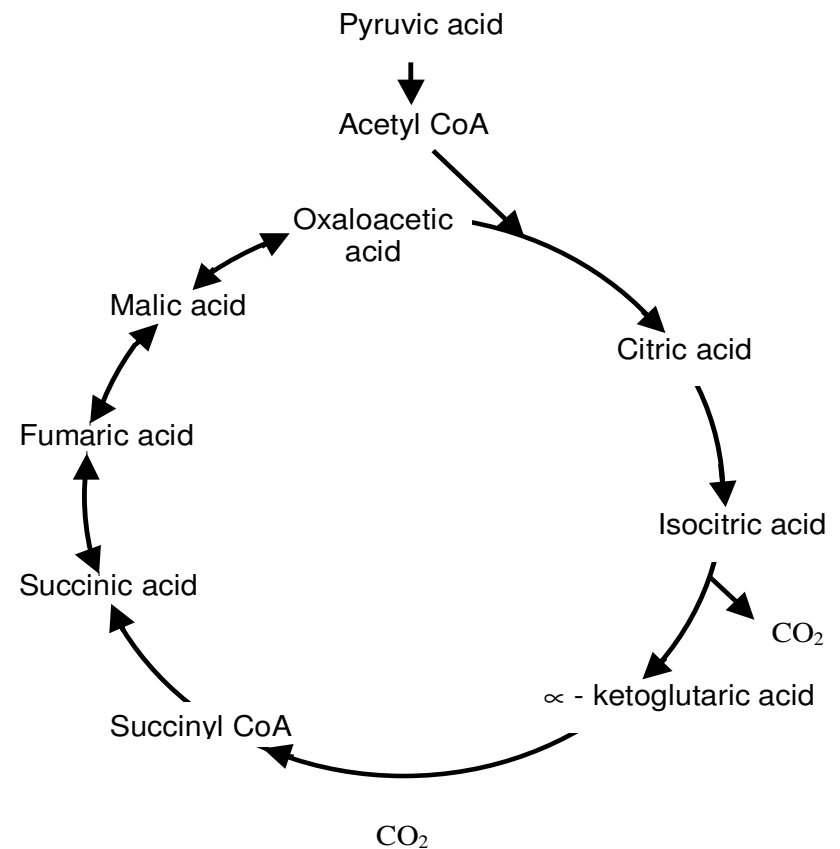
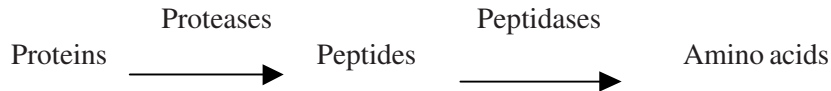


Fig.4-3: Tricarboxylic acid cycle

In the TCA cycle a bypass called **Glyoxalate bypass** occurs with the formation of glyoxalate and succinate from isocitric acid. The former ultimately forms malate by condensation with acetyl CoA. This cycle operates when the microorganisms use 2 carbon compounds like acetate as sole carbon source or in the oxidation of higher fatty acids cleaved to acetyl CoA without the intermediate pyruvic acid. This pathway does not occur in higher organisms because they do not utilize 2 carbon compounds.

## Catabolism of Proteins

Proteins are complex organic nitrogenous compounds composed of amino acids linked by peptide bonds. Amino acids are the building blocks of proteins and each protein contains 20 different kinds of amino acids. There are various kinds of proteins and each type has its specific sequence of amino acids in 3-dimensional structure. When large number of amino acids are joined together by peptide bonds it is called polypeptide chain. Proteins consist of one or more polypeptide chains which range from fewer to hundred amino acid monomers or residues or even thousand residues. Microorganisms can synthesize all the amino acids required with a few require external supply of one or more amino acids. **Escherichia coli** can synthesize all the amino acids for protein synthesis. On the other hand lactic acid bacteria must be supplied with preformed amino acids. The catabolism of proteins yields the amino acids.

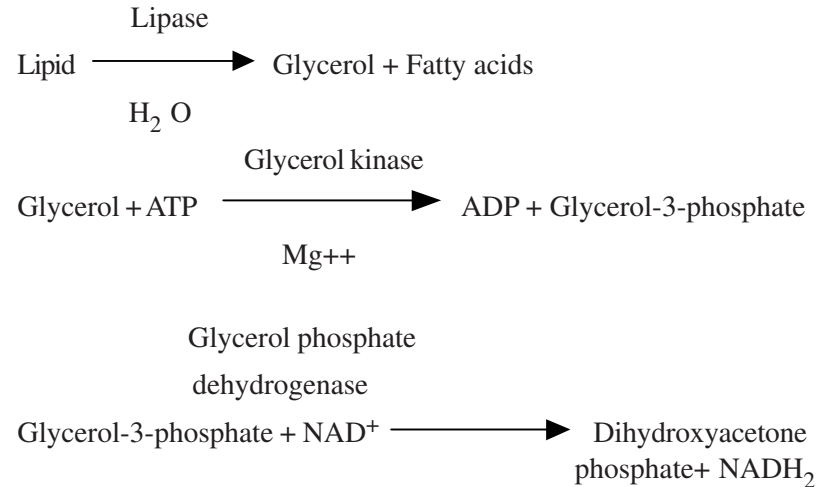


Microorganisms can degrade proteins utilizing them as a source of carbon and nitrogen. As the protein molecules are large and cannot enter the bacterial cell they elaborate exoenzymes called proteases which hydrolyze proteins to smaller peptides that are transported into the cytoplasm. Peptidases break the peptides to the individual amino acids. The amino acids are broken down according to the specific requirement of bacteria metabolizing protein and the carbon skeletons are oxidized to compounds that enter TCA cycle via acetyl CoA,  $\alpha$ -keto glutaric, succinic, fumaric or oxaloacetic acids.

## Catabolism of lipids

Lipids are triglycerides containing fatty acids and glycerol. Fat or fat like substances are present in all living cells. Braun's lipoprotein is present in the cell wall of Gram negative bacteria. Phospholipids and lipopolysaccharides of membranes and the fat like cytoplasmic inclusion- poly  $\beta$  hydroxybutyrate in bacteria are all fatty substances only. Most of the microorganisms use glucose as energy source but many of

them can derive energy from lipids and proteins as well and convert them to intermediates of glycolysis or TCA cycle.



The lipids are broken down by enzymes called **lipases** to fatty acids and glycerol. The glycerol is phosphorylated to Glycerol-3-phosphate that is converted to dihydroxyacetone phosphate which is broken down through glycolysis. Fatty acids are oxidized by  $\beta$ -oxidation by the successive removal of 2 carbon units. In that process acetyl CoA is formed which enters TCA cycle. The hydrogen atoms and their electrons enter the respiratory chain. Energy yield per gram of fat is more than per gram of carbohydrate. That is why fat is considered as a reserve product which can be utilized when required. However, because of the limited solubility of lipids only a few species metabolize lipids effectively.

## Energy

Energy is required by bacteria for construction of wall or membrane, synthesis of enzymes and other cellular components, for repair of damage if any, for growth and multiplication. Most cells obtain energy by carrying out chemical reactions that liberate energy. Light is a source of energy but this is converted to chemical energy to be useful for the cellular work. During chemical reactions energy is either re-

leased or absorbed and the quantum of energy liberated or taken up is the useful energy and is referred to Free Energy Change ( $\Delta G$ ) of the reactions. This is expressed in calories for convenience even though the force energy may be in the form of heat or chemical energy. Chemical reaction shall be either that releases energy (exergonic reaction) or requires energy (endergonic reaction) which is expressed by negative and positive value respectively. As concentration of reactants affects the value of  $\Delta G$  and for purpose of valid comparisons of energetics of different reactions, standard concentration of all reactants is presumed as 1.0.M.

referred as ( $\Delta G^\circ$ ) which is the amount of free energy released or absorbed when 1 mole of the reactant is converted to 1 mole of the product at 25°C and one atmosphere of pressure where all reactants or products are maintained 1.0 M concentration. The ( $\Delta G^\circ$ ) at pH is 7 designated as ( $\Delta G^\circ$ ).

In a sequence of reactions energy generated by a reaction can be utilized to drive another reaction requiring energy. Living organisms have exergonic reactions coupled with endergonic reactions through a common reactant to continue life. The common reactant is called energy rich or energy transfer compound.

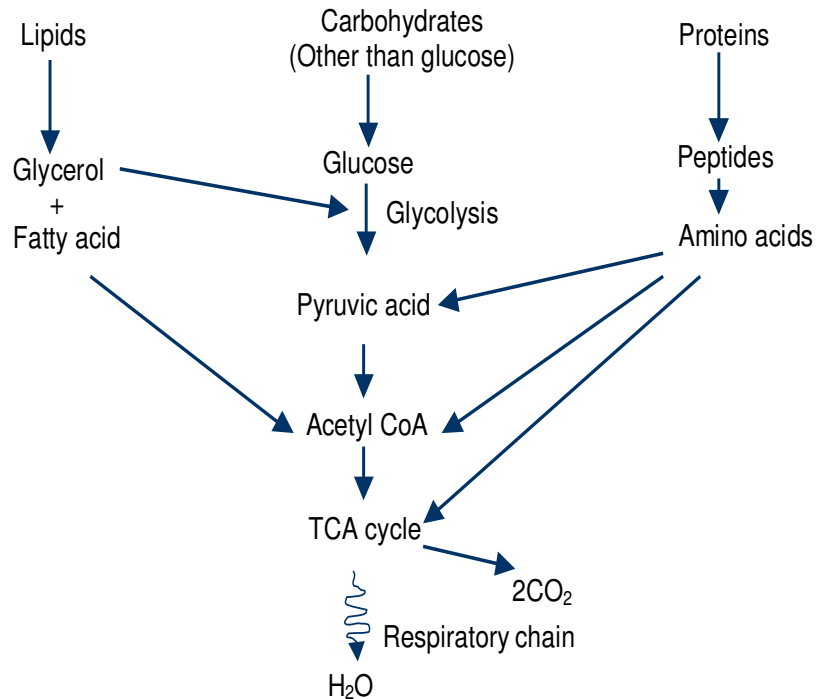


Fig.4-4. Metabolism of carbohydrates, lipids and proteins

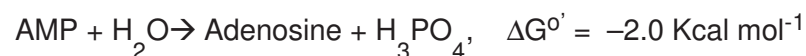
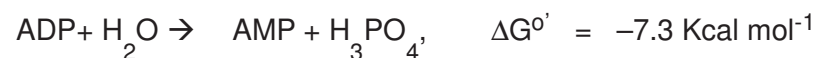
### High Energy phosphates

High –Energy-Transfer compounds are those capable of transferring large amount of free energy and a variety of such compounds exists in cells and the break down of a molecule by enzyme releases the energy. A high energy-transfer molecule is similar to a mouse trap when set has great energy in the spring opposing the action of the catch. Tripping of catch is similar to the breakdown releasing the energy.

Adenosine triphosphate (ATP) is the most important high energy transfer component found in the cell. This is the “energy currency” of the cell in the exchange of energy between exergonic and endergonic reactions. There are other energy rich compounds available in the cell. Each molecule of Adenosine, guanosine, uridine and cytidine triphosphates release  $-7.3 \Delta G^\circ$  Kcal mol<sup>-1</sup>. The  $\Delta G^\circ$  value for acetyl phosphate ( $-10$  Kcal mol<sup>-1</sup>) 1,3 diphosphoglyceric acid ( $-11.8$  Kcal mol<sup>-1</sup>) and phosphoenol pyruvic acid ( $-14.8$  Kcal mol<sup>-1</sup>) are also high energy compounds.

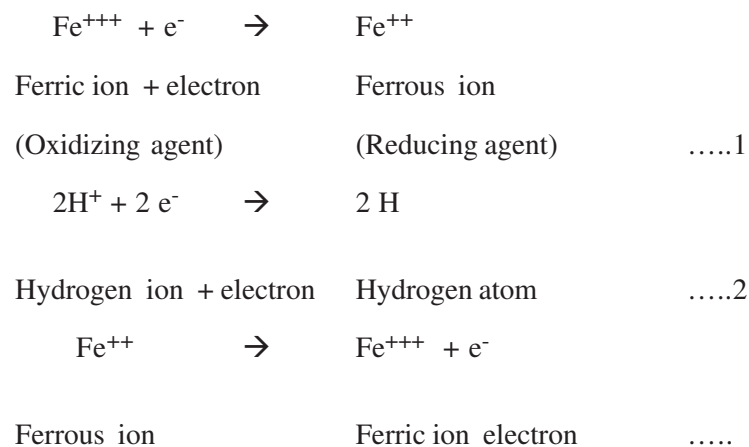
It is seen from above that all these compounds contain phosphates and phosphorylated compounds have high energy. Hydrolysis of ATP releases energy with the formation of Adenosine diphosphate (ADP) which is also a high energy transfer compound that yields Adenonine monophosphate (AMP).

The free energy change ( $\Delta G$ ) under standard concentration is



In the intact cell depending upon the pH, concentration of ATP, ADP, Mg<sup>++</sup> etc., the free energy of hydrolysis of ATP within the cell is closer to -12.5 Kcal.

Energy is released during oxidation-reduction (O/R) reactions, oxidation is loss of electron and the reverse is reduction which is gain of electron. Oxidizing agent (oxidant) will absorb electrons and get reduced while a reducing agent (reductant) donates an electron and gets oxidized in the process. An oxidant and a reductant are involved. A hydrogen atom consists of one proton and one electron and the removal of Hydrogen is also oxidation process as an electron is lost in the removal. Therefore oxidation-reduction reactions are dehydrogenations involving loss of hydrogen atoms.



In the above two processes Ferric ion and Hydrogen ion are oxidizing agents that accept an electron and get reduced. In the process

(3) ferrous ion, a reducing agent, donates an electron and gets oxidized to Ferric ion.. The above processes indicate that reverse of each oxidation is reduction and the reverse of each reduction is oxidation and in each reaction a pair of substances viz., a reduced and an oxidized form (eg.) Ferrous and Ferric ion are involved. Such a pair is called oxidation-reduction (O/R) system. An O/R system (A) may absorb an electron from another system (B) thus oxidizing (B). The power of tendency to absorb electrons is expressed as standard oxidation-reduction potential or electromotive force ( $E_o'$ ) of the O/R system.  $E_o'$  is measured electrically under standard conditions wherein e<sup>-</sup> donor and its conjugate at 1.0 M concentration at 25°C and pH 7 and expressed in volts. The more positive the  $E_o'$  the greater is the oxidizing ability of the system. When one O/R system oxidizes another energy is released. If the voltage difference is large, an amount of free energy enough to synthesise ATP may be liberated. There are a variety of O/R systems in living organisms (Table 1).

**Table 1:** O/R system in the respiratory chain

O/ R system	$E_o'$ V
NAD /NADH <sub>2</sub>	Nicotinamide
	Adenine dinucleotide      -0.32
FAD / FADH <sub>2</sub>	Flavin adenine dinucleotide      -0.03
CoQ / CoQH <sub>2</sub>	Coenzyme Q (Ubiquinone)      +0.04
Cyt. b – Fe <sup>3+</sup> / Cyt. b Fe <sup>2+</sup>	Cytocromes      +0.07
Cyt. a <sub>3</sub> -Fe <sup>3+</sup> / Cyt. a <sub>3</sub> Fe <sup>2+</sup>	+0.53
Oxygen / Water	+0.82

### Respiration

In respiration oxidation of organic compounds occurs and the oxidizable substrate is the primary electron donor. Glucose (C<sub>6</sub>H<sub>12</sub>O<sub>6</sub>)



is oxidized to pyruvic acid ( $\text{CH}_3\text{COCO}_2\text{H}$ ) which is ultimately oxidized to  $\text{CO}_2$ . The energy contained in glucose is fully liberated as the C is completely oxidized to  $\text{CO}_2$ . In this respiration the terminal electron acceptor is oxygen (oxidant). Anaerobic respiration also occurs in some organisms where other inorganic compounds (other than oxygen) like  $\text{NO}_3^-$ ,  $\text{SO}_4^-$  or organic compounds like fumarate serve as final electron acceptor. In fermentation an organic compound is the final electron acceptor and the oxidizable substrate is the electron donor. For instance in glucose ( $\text{C}_6\text{H}_{12}\text{O}_6$ ) fermentation by yeasts ethanol ( $\text{C}_2\text{H}_5\text{OH}$ ) and  $\text{CO}_2$  are formed. Ethanol is more reduced and still contains energy while the  $\text{CO}_2$  does not contain any energy. A part of the glucose carbon is oxidized to  $\text{CO}_2$  and a part reduced to ethanol serving as electron donor and acceptor. In photosynthetic bacteria bacteriochlorophyll serves as  $e^-$  donor and acceptor. In photosynthesis of plants, eucaryotic algae and prokaryotic cyanobacteria (Blue Green algae) water is the primary electron donor and  $\text{NADP}^+$  is the terminal acceptor. The flow of electrons in various processes is called electron transport chain. The sequences of oxidation-reduction reactions are mediated by a variety of electron carriers or electron carrying enzymes. The free energy released during the flow of  $e^-$  in the electron transport chain is conserved in the form of ATP. As this is an oxidative process this type of formation of ATP is known as Oxidative Phosphorylation. Respiratory chain is an electron transport chain where a pair of  $e^-$  or hydrogen atoms containing electron from the substrate oxidized is coupled to reduction of oxygen to water.

Here the flow of electron liberates energy which is conserved in the form of ATP. Enzymes having prosthetic groups or coenzymes constitute the respiratory chain. Each of them is an O/R system with an oxidized and reduced form. They are Nicotinamide Adenine dinucleotide (NAD), Nicotinamide Adenine Dinucleotide Phosphate (NADP), Flavin Adenine Dinucleotide (FAD), Flavin mononucleotide (FMN), Coenzyme Q (also called Ubiquinone) and Cytochromes.

Three ATP molecules are formed per molecule of  $\text{NADH}_2$  oxidized. Energy production is also done in photosynthesis. Photo-

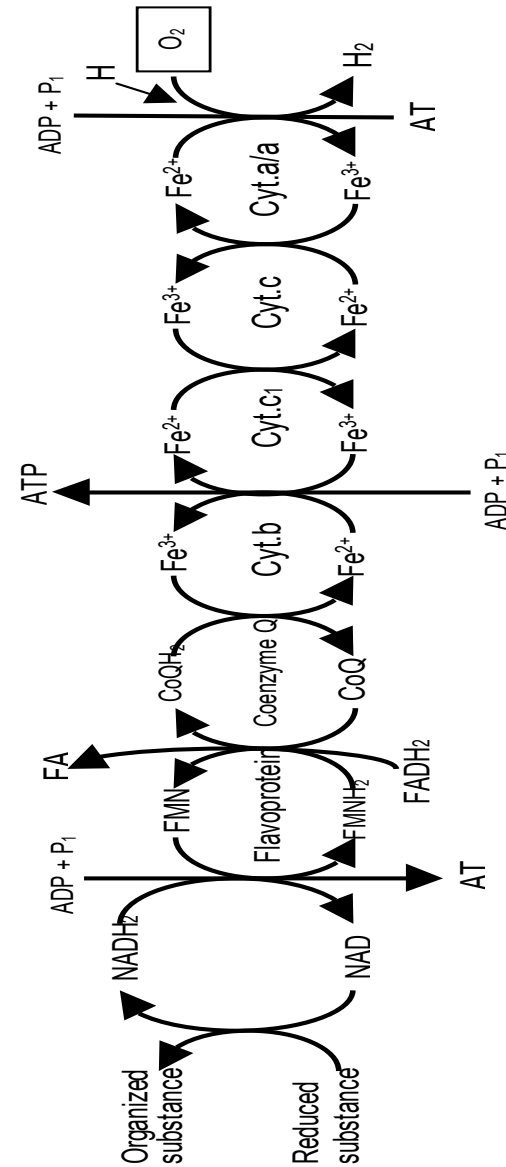


Fig. 4-5 Respiratory chain showing the sequential oxidation and ATP synthesis

synthesis is a process of reduction of  $\text{CO}_2$  to carbohydrate utilizing the light as energy source using water as reductant. Photoautotrophs like plants, algae and blue green algae use light as their energy source and  $\text{CO}_2$  as sole source of carbon. Anoxygenic photosynthetic bacteria do not use water for photosynthesis but use inorganic compounds like  $\text{H}_2$ ,  $\text{H}_2\text{S}$  or  $\text{H}_2\text{S}_2\text{O}_3$ , organic compounds like lactate or succinate. Photophosphorylation occurs on both the types of photosynthesis and during the electron flow energy is released with synthesis of ATP. Cyclic photophosphorylation occurs in photosynthetic bacteria as the Bacteriochlorophyll excited by light adoption and releases an electron which passes high ferredoxine ubiquinone cytochrome b and cytochrome f and returns to bacteriochlorophyll. ATP is synthesised when  $e^-$  flows from cyt b to cyt f.

In plant photosynthesis, the absorption of light in pigment system-II releases an  $e^-$  which flows through plastoquinone, cytochrome b and f and finally pigment system. When pigment system I absorbs light an  $e^-$  is released which flows through ferredoxin, flavoprotein and to  $\text{NADP}^+$ . The  $e^-$  does not return to its place. Hence known as non cyclic flow. Two ATP molecules are synthesised when  $e^-$  flows from cyt b to cyt f in system II and another when  $e^-$  flows to ferredoxin from the excited pigment. This type of phosphorylation is **non cyclic** photophosphorylation.

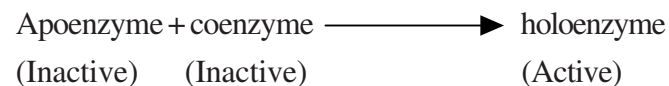
In both oxidative phosphorylation and photosynthetic phosphorylation ATP synthesis is coupled with  $e^-$  transfer. The energy released during oxidation of an organic molecule to another can also be used for ATP synthesis. This is known as substrate level phosphorylation and occurs in glycolysis.

## ENZYMES

A multitude of chemical changes occur in living cells in breaking down complex food substrates into their simpler compounds and also in synthesizing cellular materials. These changes are accomplished by **enzymes**. The word 'ferments' was used originally as they acted similar to yeast fermentation. But Kühne (1878) coined the term

enzyme. Photomeaning "in yeast" in Greek. Enzyme is defined as an organic catalyst elaborated by a living cell which accelerates the chemical changes. All enzymes are produced within the cell but some are excreted out and function in the cellular environment and many others act within the cell. Those that are excreted out are known as **extracellular enzymes or exoenzymes**. These enzymes help in the degradation of complex food substances that cannot enter the cell directly. Cellulases excreted by the microbes degrade cellulose into its component glucose. Glucose is absorbed by the cell. Those functioning within the cell are called as **intracellular enzymes or endoenzyme**.

Enzymes produced by a bacterium, fungi, plants and animals are similar in characteristics. They are proteins or proteins combined with other chemical groups. The protein portion is called **apoenzyme** and the low molecular weight organic group is called **coenzyme**. Apoenzyme and coenzyme in combination is known as **holoenzyme** which is active on substrate. Apoenzyme is a high molecular weight (protein) compound not dialyzable and inactive against substrate. Coenzymes are low molecular weight organic compounds easily dialyzable through a semipermeable membrane and itself is inactive against substrate. On the other hand when apo enzyme and coenzyme combine together to become holoenzyme which is active on substrate. Several of the B vitamins are components of coenzymes.



For example thiamine ( $\text{B}_1$ ) is in cocarboxylase, riboflavin in riboflavine adenine dinucleotide and niacin in Nicotinamide adenine dinucleotide. In some enzymes the non protein part of the enzyme is a metal like iron as in catalase. The metal ion may be bound with protein tightly or loosely bound (easily dialyzable) depending upon the enzyme. Many enzymes require the metal ions like  $\text{Mg}^{++}$ ,  $\text{Fe}^{++}$ ,  $\text{Zn}^{++}$  etc. to get activated. The metal ions combine with enzyme protein and are

referred as **inorganic coenzymes** or **cofactors**. In case of certain enzymes both a cofactor (Inorganic) and a coenzyme(organic) are required for enzyme activation.

A substance acted upon by an enzyme is called substrate. Substrate can be a food substance comprising of starch, protein etc. as in the case of animals which eat food and digest it. In microorganisms, plant and animal debris containing complexity of materials are the food substrates. The substrate is acted upon by enzymes and get transformed or degraded to its components. For instance starch is degraded by amylase, proteins by proteases and lipids by lipases. Proteins after enzyme action results in amino acids that are the building blocks of proteins. The cell utilizes the amino acids for its own cellular material synthesis. Enzymes are specific to substrates. The enzyme lipase acts on lipids only and not on protein. Similarly proteases act on proteins only and not on starch or lipid. Therefore a host of enzymes occur in a cell to perform various functions. Over 1000 different enzymes are known today and more and more will be discovered in the future. Most enzyme names end in *ase* (e.g. amylase, protease, lipase) except enzymes like rennin and pepsin. Based on the function or catalytic reactions enzymes are broadly classified as **Hydrolases** (hydrolysis reaction) **transferases** (transfer functional groups), **Oxidoreductases** (electron transfer reactions) as so on.

The action of an enzyme on a substrate is specific and both the enzyme (E) and the substrate (S) combine together to form an Enzyme Substrate (ES) complex. The enzyme substrate complex breaks up after the reaction forming the product (P) and enzyme (E). The substrate is broken down by the enzyme substrate complex which breaks up after the reaction forming the product (P) and enzyme (E). The substrate is broken down by the enzymes to its products but the enzyme is not lost or used up in the reaction and reacts with another substrate molecule. It will be of interest to note the specificity of enzymes as numerous enzymes and substrates may be present together. The substrate has a chemical affinity to certain areas of the enzyme surface which are called “active sites”. The substrate attaches to the active sites and gets altered according to the enzyme.



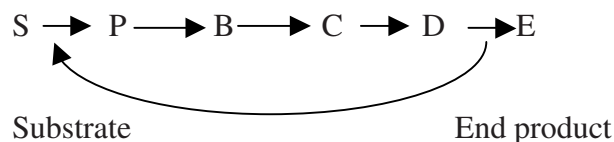
E = Enzyme, S = Substrate,  
ES = Enzyme substrate complex P = Products.

**Fig. 4-6.** Enzyme substrate reaction (a model )

### Enzyme regulation by feed back inhibition

All the catabolic reactions are self regulatory. When one of the reaction products accumulates it naturally suppresses its formation by inhibiting the enzyme catalyzing its formation. A living cell contains more than a thousand different enzymes but all of them acting together in a coordinated manner so that all the activities of the cell are integrated with one another. Therefore microorganisms possess a variety of enzyme regulatory mechanisms. The enzyme action in a metabolic sequence can be regulated, by the end product formed. The end product inhibits the activity of the enzyme in first reaction of the biosynthesis. This type of regulation of enzyme by the end product is called as end-product inhibition or feed back inhibition. By this way the microorganisms and cells restrict overproduction of a metabolite like amino acids.

The activity of an enzyme is influenced by (1) the concentration of enzyme (2) concentration of substrate, (3) pH and (4) temperature. There shall be an optimum relation between the concentration of enzyme and substrate for maximum activity.



**Fig. 4-7 :** Feed back inhibition

The function of each enzyme is optimum at a particular pH and temperature. Extreme variation in pH and high temperatures can destroy the enzymes as they are protein in nature. The activity of an enzyme shall be inhibited by a chemical and this may be reversible or nonreversible. Non reversible inhibition is due to modification or inactivation of functional groups of enzyme.

For example mercury reacts with sulfhydryl (-SH) groups of enzyme and inhibits enzyme action. Reversible inhibition may be competitive or non competitive. Competitive inhibition can be nullified by increasing the concentration of a substrate whereas non competitive inhibition cannot be reversed. Compounds having a similar structure like that of a substrate can non-competitively inhibit enzyme action. Certain chemical substances like cyanide have affinity for metals in enzymes and cyanide inhibits iron containing enzymes as cyanide ties up the iron.

#### Points to remember

1. In glycolysis one molecule of glucose is converted to 2 molecules of pyruvic acid.
2. Two ATP molecules are the net gain in glycolysis.
3. Pyruvic acid is a key intermediate for many different metabolites.
4. In aerobic organisms glucose is converted to pyruvic acid which is completely oxidized to  $\text{CO}_2$  through TCA cycle.

5. Anaerobic organisms reduce pyruvic acid formed in glycolysis to compounds like ethanol, propanol and acetone.
6. Fermentation is an energy yielding reaction in anaerobes.
7.  $\text{NADH}_2$  is formed in TCA cycle and the energy contained in them is used up in respiratory chain for ATP synthesis.
8. Glyoxalate bypass in TCA cycle operates in microorganisms utilizing two carbon compounds like acetate.
9. Proteases release aminoacids from proteins.
10. Lipids are hydrolysed by lipases to glycerol and fatty acids.
11. ATP contains a higher energy phosphate bond.
12. ATP is synthesized by substrate level phosphorylation, Oxidative phosphorylation and by photophosphorylation
13. One mole of ATP releases 7.3 k cal energy.
14. Cytochromes are the electron transfer agents.
15. The terminal electron acceptor in respiration is oxygen
16. In anaerobic respiration inorganic compounds like nitrate and sulphate act as terminal electron acceptor and not oxygen.
17. Enzymes are organic catalysts that accelerate chemical changes in cells.
18. Coenzymes are low molecular weight dialyzable organic compounds.
19. Cofactors are metal components required for the enzyme action.
20. Apoenzyme is the protein portion of the enzyme.
21. Enzyme is reused after the reaction with substrate.
22. Chemical agents like mercury inhibit the sulfhydryl group of enzyme.
23. Feed back inhibition is due to the accumulation of the end product inhibiting the first step of the reaction.

## SECTION -II

### Chapter - 5

## ENVIRONMENTAL MICROBIOLOGY

The study of microorganisms was recognised in the early days for its existence and its importance in medical and industrial fields. In the recent days, microbiology is becoming a diversified subject like any other science. Microorganisms are gaining more importance as they are causing serious environmental problems. The role of microorganisms as fighters of pollution has also been appreciated.

Environment is the sum total of external influences acting on organism or population. Environment includes water, air and land and the inter-relationship, which exists among and between water, air and land living organisms and their properties. The Indian mythology described the environment as 'Panja Maha Budhas', Akas, Vayu, Aap, Prith and Agni (sky, air, water, earth and fire). They all believed to interact to maintain the balanced state both in the environment and organisms. In the environment biochemical changes occur due to the action of microorganisms.

The first United Nations Conference on Environment and Development (UNCED) was held at Stockholm, Sweden on 5<sup>th</sup> June 1972. In memory of the date, the **World Environment day** is celebrated every year on June 5<sup>th</sup>.

Microbes were the first to appear on the earth. They are universally present and innumerable, a gram of soil contains more than 100 million microbes. They are deeply involved in evolution, biosphere changes and ecological complexities. Microorganisms possess unique capabilities of degrading wastes, generated by industrialization and other activities of expanding human population.

Microorganisms play a prominent role in the following aspects of global ecology. (1) Microbial activities on organic and inorganic substrates in soil, water, air and cycling of bioelements occupy a key position in food chain and energy flow in biosphere. (2) Autotrophic microorganisms participate in primary production along with plants. (3) The role of microbes as pathogens and symbionts is important in global ecology.

Microbial ecology and environmental microbiology are closely related fields. Microbial ecology is the study of microbial activities in natural environment and environmental microbiology is the study of microbial activities in both natural and man made environments. It has recently emerged as a field of specialization and applications of microbes for solving environmental problems.

### 5.1 Air pollution

Air pollution may be defined as the presence in the atmosphere of one or more contaminants or combination thereof in such quantities or may tend to be injurious to human, animals and plants. Otherwise, air pollution can be defined as any undesirable change in physical, chemical and biological characteristics of air that may be harmful to living organisms and living conditions.

Excessive release of air pollutants in the atmosphere by human activities disturb the dynamic equilibrium in the atmosphere and thereby affect man and his environment.

#### 5.1.1 Sources of air pollution

The most common gaseous air pollutants are carbon monoxide, sulphur dioxide, oxides of nitrogen, hydrogen sulphide, chlorine, carbon dioxide, hydrocarbon and oxidants. The other pollutants in the air are dusts, heavy metals like cadmium and chromium. The major sources for carbon dioxide pollutant are incomplete combustion of fuels, automobile exhausts, jet engine emissions, blast furnaces and tobacco smoking. The major sources for sulphur dioxide pollutant are combustion of coal, petroleum industries, oil refining industries, power

houses and sulphuric acid plants and metallurgical operations. The major source for oxides of nitrogen are in addition to automobile exhausts, boilers, explosives industry and manufacture of nitric acid industry and combustion of wood and refuse.

### 5.1.2. Air pollution impact on human health

Air pollution causes several impacts on human being. It includes toxicity, blood poisoning, increased proneness to accidents, suffocation, aggravation of asthma and chronic bronchitis, impairment of pulmonary functions, irritation of throat, eyes and nose, headache, irritation of respiratory tract etc.

### 5.1.3. Aerosol

Aerosol can be defined as water droplets containing several types of microorganisms released into the air from various sources. Air currents may also bring the microorganisms from plant or animal surface into the air.

### 5.1.4. Droplet, Droplet nuclei

Sneezing, coughing or talking usually form droplets. Each consists of saliva and mucus. Droplets may also contain several thousands of microorganisms, which may be pathogenic, if discharged from diseased person. Pathogens are mostly of respiratory tract origin.

**Droplet nuclei** : Small droplets in a warm dry atmosphere tend to evaporate rapidly and become droplet nuclei. Thus, the residue of solid material, left over after drying up of a droplet is known as droplet nuclei.

## 5.2. Air-borne diseases

The sources of microbes in air are many - soil, water, decaying bodies and diseased persons. There are several diseases caused by air-borne pathogens. They are found commonly in the air. The air is one of the important routes and a number of diseases have been shown to be transmitted through air. The important air-borne diseases and their causative agents are given in Table I.

Table - I

Sl. No.	Name of the disease	Causative agent
<b>Bacterial diseases</b>		
1.	Brucellosis	<i>Brucella species</i>
2.	Streptococcal pharyngitis	<i>Streptococcus pyrogenes</i>
3.	Tuberculosis	<i>Mycobacterium tuberculosis</i>
4.	Diphtheria	<i>Corynebacterium diphtheriae</i>
5.	Streptococcal pneumonia	<i>Streptococcus pneumoniae</i>
6.	Psittacosis	<i>Chlamydia psittaci</i>
7.	Meningococcal meningitis	<i>Neisseria meningitidis</i>
8.	Pneumonia	<i>Mycoplasma pneumoniae</i>
<b>Fungal diseases</b>		
9.	Cryptococcosis	<i>Cryptococcus neoformans</i>
10.	Blastomycosis	<i>Blastomyces dermatitis</i>
11.	Aspergillosis	<i>Aspergillus fumigatus</i>
<b>Viral diseases</b>		
12.	Common cold	<i>Rhinovirus</i>
13.	Influenza	<i>Orthomyxovirus</i>
14.	Mumps	<i>Mumps virus</i>
15.	Measles	<i>Measles virus</i>

## 5.3. Microbial standards of drinking water

The number of coliforms per 100 ml of water sample is estimated to find out the quality of water and its suitability for drinking

purposes. Bureau of Indian Standards (BIS) has prescribed the tolerance limits of total coliforms and fecal coliforms in water. In addition to coliforms, coliphages, clostridia and human enteric viruses are also monitored in drinking water. Biological Oxygen Demand (BOD) limits in drinking water should be below 3 ppm or 3 mg per litre.

**Table II - Microbial standards of drinking water**

Sl. No.	Particulars	limit
1.	Total coliform (MPN / 100 ml)	< 50
2.	Fecal coliform (MPN / 100 ml)	< 0.0
3.	Coliphages	0.6%
4.	Clostridia	1.9%
5.	Human enteric viruses	0.0%
6.	BOD mg / litre	< 3

*Adapted from Payment (1991)*

## 5.4. Sewage treatment and disposal

Sewage is the used and waste water consisting of human excreta, wash waters, and industrial and agricultural wastes that enter the sewage system. In general, sewage contains 95 per cent water and 5 per cent organic and inorganic materials. The solid remains in suspended form in water. There are several methods of sewage treatment on small scale such as cesspools and septic tanks. Sewage or waste water treatment aims to purify the water for reuse or recycling. There are three important treatments for disposal of waste water. They are primary, secondary and tertiary treatments.

### 5.4.1. Primary treatment

Primary treatment is the physical removal of 20-30 per cent of organic materials present in sewage in particulate form. It removes only suspended solids and floating matter. The particulate material is

removed by screening, precipitation of small particulate and settling in basin or tanks where the raw sewage is piped into huge and open tanks. The solid material (sludge) is removed and kept in landfill / composting for anaerobic digestion. The liquid portion is piped into sludge tanks. The accumulated materials in sludge tanks are subjected to aluminium sulfate or the other coagulants so that the suspended particles, organic materials and microorganisms should be trapped as in sedimentation process of water purification. Primary treatment of sewage removes 30-40 per cent of the BOD and secondary treatment is necessary for acceptable BOD reduction

### 5.4.2. Secondary treatment

It is also called biological treatment or microbial degradation. By this process, 90-95 per cent of the BOD and many pathogens are removed. There are several means by which BOD can be reduced in secondary treatment. Reduction of BOD is achieved through mineralization of small fraction of organic matter and conversion of portion to removable solids. Secondary treatment is done by several methods as described below :

**a) The oxidation pond :** The oxidation pond permits the growth of algal forms on waste water effluent. It is used for secondary treatment in rural areas or industrial sectors. The organic materials are degraded by heterotrophic bacteria into simpler forms that in turn support the growth of algae. Algae use these nutrients to increase their biomass. Air supplies oxygen for biochemical oxidation of organics. In the secondary treatment, organic matter is stabilized and the BOD is reduced aerobically and this is called as the activated sludge process. During this treatment, the sewage liquid is aerated vigorously and as a consequence the organic matter is converted into gases and a very small amount of this is incorporated into cell biomass. This step relies on microbial activity and hence it is also referred as biological treatment.

**b) The trickling filter :** Aerobic secondary treatment also can be carried out with a trickling filter. It is a simple sewage treatment device that consists of a bed of crushed stone, gravel, slag, or synthetic

materials with drains made at the bottom of the tank. Thus the trickling filter has a pile of rocks over which sewage or organic wastes slowly trickle. A revolving sprinkler is suspended over a bed of porous material, which distributes the liquid sewage over it, and collects the effluents at the bottom.

**c) The activated sludge process :** It is also one of the widely used aerobic treatment systems for waste water in which very vigorous aeration of the sewage is done. The sewage is passed into an aeration tank from primary settling tank. Sewage is aerated by mechanical stirring. Due to vigorous aeration of sewage floc-formation occurs. The colloidal and finely suspended matter of sewage form aggregates, which are called floccules. The flocs are permitted to settle down in secondary settling tank.

#### 5.4.3. Tertiary treatment

Tertiary treatment is aimed to remove non-biodegradable organic materials, heavy metals and minerals. The salts of nitrogen and phosphorus must be removed because they cause eutrophication. By using activated carbon filters the organic pollutants can be removed, whereas by adding lime the phosphorus is precipitated as calcium phosphate. Nitrogen can be removed by volatilization as ammonia at high pH values. Ammonia can be converted by chlorination to dichloromine, which in turn is converted to nitrogen. The final step in sewage treatment is disinfection designed to kill pathogenic microorganisms. Disinfection is accomplished by chlorination using chlorine gas or hypochloride. They react with water to yield hypochlorous acid, which is a strong oxidant and antibacterial agent. The treated water can be used. Tertiary treatment is very expensive.

#### 5.5. Eutrophication

Water, containing optimum nutrients, enriched with organic and inorganic nutrients, is termed as eutrophy. The enriched nutrients allow excessive growth of algae and water plants and that condition is called Eutrophication. It causes depletion of oxygen, foul smell through generation of sulphides and death of non-resistant organisms. It results in

the colonization of such water by a particular group of organisms, cause sedimentation and eventually gets filled with resistant type of organisms.

#### 5.6. Recycling of waste

Recycling is not a complete process, unless the legal and institutional framework can create markets for the recycled products. It can beneficially utilize the materials picked up from the curb.

Many of the solid wastes generated by steel making plants can be reused and recycled and thus, can become a resource for industrial production or energy production if properly managed. The term 'recycling' bears a much greater significance than just providing an alternative method for treatment of solid wastes. In recycling, our main aim is to separate the hazardous or toxic metals from the solid wastes by easy and economic means. The metal concentrate thus obtained can be recharged in Electric Arc furnace, in pelletized or in sintered form. This to some extent, cuts down the cost of raw materials. The residue obtained after the separation of the toxic materials can be reused or can be disposed off as an eco-friendly substance. The re-use of the residue can be used as building materials.

##### 5.6.1. Composting methods

Compost is defined as the mixture of decayed organic matter, manure etc., added to soil to improve the growth of plants. Generally, two methods are employed for making compost.

##### 5.6.1.1. Indore method

A compost pit is dug near the cattle shed. Generally pits of 3x6x6 are prepared for compost making. The plant residues are spread into the cattle shed to prepare a bed for the cattle. By this process, the plant materials are wetted by the excreta. These wet materials are then removed from the cattle sheds along with animal's excreta and spread into the compost pit. The waste materials are added upto 3 feet from the bottom of the pit. Over this layer sufficient quantity of cattle dung is spread and water is sprinkled over these layers. The cattle dung may



be added to the pit till the layer reaches 1 foot above the ground level. Proper turning of these residues at regular intervals of 10 days gives good quality of compost within 8 weeks. This is an aerobic method.

#### 5.6.1.2. Bangalore method

It is another method of composting. For this method, the area selected must be away from cities and also it should be waste land. In this method of composting, trenches of 4.5 to 10 metre long, 1.5 to 2.5 metre wide and 1 metre deep are dug. The trenches are filled with alternative layers of refuses and black soil. The height of the top layers should be about 250 mm in thickness and the layer should be of refuses. Then the refuse layer is covered with black soil. The layer of black soil is about 50 mm in thickness. Owing to the anaerobic action of microbes, the temperature of the refuses increases upto 70°C within seven days. The heat will persist in the compost mass for 2-3 weeks. The heat helps the anaerobic decomposition of wastes into the compost. It also kills all the pathogenic microorganisms present in the waste. As a result, good quality of compost is formed within 4 months.

#### 5.6.2. Biogas production

Biogas is produced through a process of anaerobic fermentation of organic materials. Biogas consists of 55-70% methane and 30-45% carbon dioxide as well as small quantities of gases like ammonia and hydrogen sulphide. The anaerobic digestion is carried out in an air tight cylindrical tank which is called biogas digester. A digester is made up of concrete bricks and steel. Gas holder is made up of steel, which moves up and down on guide according to quantity of gas stored in it. The sides of the drum remain in the slurry to seal the leakage of gas. This type of digester is called floating drum eg. KVIC (Khadi Village Industries Corporation)

##### 5.6.2.1. Operation of biogas plants

Cowdung is mixed with equal amount of water and made into slurry and fed through the inlet into the biogas digester. The digestion proceeds around a temperature of 35°C, at pH 6.8-7.5 and with sufficient amount of nitrogen and phosphorus. The production of gas sets

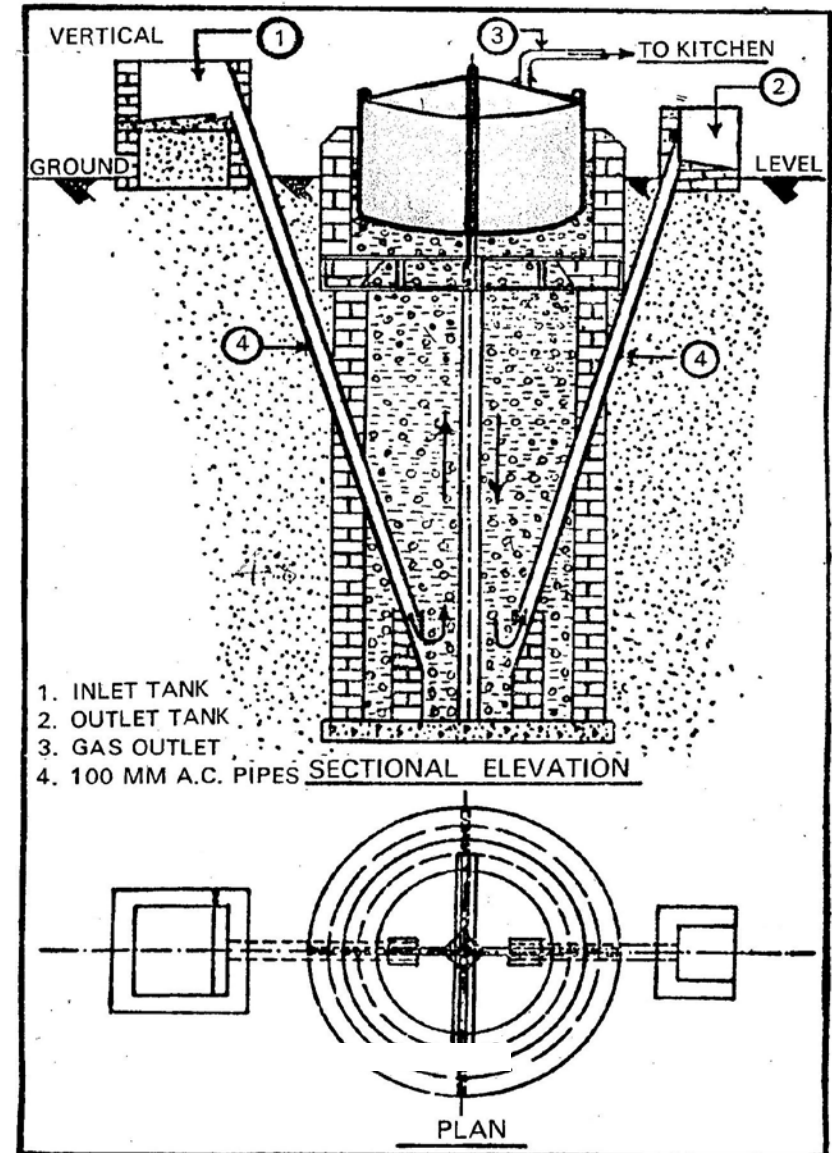


Fig. 5-1. Biogas plant KVIC design

40-50 days. The gas produced in the digester is accumulated in the drum and is used as a fuel through an opening on the top of the gas holder drum.

#### 5.6.2.2. Production of biogas

Under anaerobic condition, production of biogas is accomplished in three stages, namely hydrolytic fermentative, acetogenic and methanogenic stages.

##### Hydrolytic fermentative stage

It is the initial stage when feed stock is solubilized by water and enzyme. The complex polymers are hydrolysed into organic acids and alcohol by hydrolytic fermentative bacteria. The first group of bacteria include *Bacillus*, *Cellulomonas*, *Clostridium*, *Ruminococcus*. These bacteria catabolize carbohydrates cellulose, proteins, lipids to simple sugars and fatty acids.

**Acetogenic stage** : In this stage, the second group of bacteria like *Acetivibrio cellulosolvens*, *Bacteroid cellulosolvens* (Facultative anaerobic and hydrogen producing acetogenic bacteria) convert the simple organic materials (via oxidation- reduction reactions) into acetate, hydrogen and carbondioxide. These substances serve as food for final stage group of bacteria.

**Methanogenic stage** : This the final stage of anaerobic digestion where acetate hydrogen and carbondioxide are converted by the strict obligate anaerobic methane producing bacteria into methane (biogas), carbondioxide and other traces of gases. The methanogenic bacteria include *Methanobacterium formicum*, *Methanobacterium thermoautotrophicum*, *Methanococcus voltae* and *Methanomicrobium mobile*.

#### 5.6.2.3. Uses of biogas

Biogas is used as a better and cheaper fuel for cooking, lighting and power generation to run machines. It is used for improving the hygienic conditions. The biogas technology provides effective way for

sanitary disposal of human and animal wastes. As a smokeless fuel, it will reduce the incidence of eye and lung diseases. The biogas is used as fuel gas in rural places thereby reduces the consumption of fuel wood and reduces burden on forest to supply fuelwood. The digested slurry released from the biogas digester is used as enriched manure to improve the soil fertility.

##### Points to remember:

1. Understand the air pollution and its impact on human health.
2. Know the diseases transmitted through air.
3. Aware of the quality of drinking water.
4. To know the different ways of disposal of waste water.
5. To understand eutrophication in ponds.
6. To realize the importance of waste recycling and biogas production.

## Chapter - 6

# FOOD MICROBIOLOGY

## BIOGEOCYCLES, BIOFERTILIZER

### 6. Food Microbiology : Introduction

Food is a basic requirement of man than even shelter and clothing. It is the source of nutrients and provides the energy required for all activities of a human body, such as growth, repair of the damaged tissues, reproduction and sustenance. So the food should be free from microorganisms. The first person to appreciate and understand the presence and role of microorganisms in food was Pasteur. In 1837, he showed that souring of milk was caused by microorganisms and also he used the heat for the first time to destroy undesirable organisms in milk, wine and beer. This process is well known now as pasteurization. Food is an indispensable substrate for all living organisms. All food items are associated with microorganisms in one form or other. Some of the naturally occurring foods such as fruits and vegetables contain number of microorganisms. Foods get contaminated during handling, harvest, transport and storage. Food forms ideal culture medium for the growth of the microorganisms. The study of microorganisms associated with food, food poisoning and their role in the welfare of human beings both in harmful and useful ways form the subject of food microbiology.

#### 6.1. Food preservation

Food preservation is a technique to prevent spoilage, food infection, food poisoning and microbial contamination from the food. Food preservation is done with following aspects: a) to prevent and to remove microbial contamination and also to inhibit microbial growth and metabolism. (b) to kill the contaminating pathogens and to minimize food spoilage and food poison.

#### 6.1.1.Principles and methods of food preservation

The basic principle of food preservation primarily involves the process of inhibiting

- i) the growth and activity of microorganisms
- ii) the activity of endogenous enzymes
- iii) the chemical reactions which may determinate quality of food and
- iv) invasion and spoilage by insects and rodents.

In addition, spoilage of food may be caused during mechanical handling, processing, packaging, storing and transportation. Appropriate care has to be taken to prevent deterioration of quality of food. Several methods are available for preservation of food based on the above principles. The methods include 1) preventing the accessibility of food to microorganisms by *asepsis* packaging, 2) physical removal of microorganisms from food by filtration or centrifugation, 3) hindering the growth and metabolic activity of microorganisms by use of preservatives, use of low temperature and decreasing water activity in foods by drying 4) killing of the microorganisms by use of high temperature and ionizing radiations, 5) inactivation of endogenous enzymes by moderate heating, 6) inhibition of chemical reactions through the use of chemical additives, 7) fermentation of foods to yield more stable or less perishable food products.

Food preservation as it is practiced in the industry always involves the use of combination of methods for achieving maximum effectiveness.

Asepsis or preventing the accessibility of food to microorganisms is well exemplified in nature. The protective covering on natural foods such as skins on fruits and vegetables, shells on eggs and nuts and skins and membranes on livestock and fish prevent the attack by microorganisms and maintaining the living tissues in healthy condition. Filtration or centrifugation is adopted to physically remove microorganisms particularly in liquid foods such as milk, soft drinks, fruit juices and alcoholic beverages. The use of preservatives and additives in

food processing and preservation and fermentation to enhance the shelf life of the foods.

## 6.2. Decomposition of organic matter

Decomposition and photosynthesis are the two important processes of an ecosystem. Litter is an organic chemical-carrier of nutrients present in different ecosystems. The rate of decomposition is the function of structural components of litter i.e. the structural components of litter governs the rate of decomposition.

Microorganisms depending on substrate specificity colonize the organic matter and decompose it. However, the organic matter serves two functions for microflora. Firstly, it provides energy for growth and secondly it provides carbon source for the formation of new cells. During this process, certain waste products are also produced by microorganisms e.g. organic acids, carbon dioxide, methane, etc. The process of conversion of substrate to protoplasmic carbon is known as assimilation. About 20-40% substrate is assimilated and rest is released as carbon dioxide or accumulated as waste. When the carbon assimilation occurs the other inorganic chemicals such as nitrogen, phosphorus, potassium and sulphur are also taken up for the formation of new cells. By this process, microorganisms accumulate inorganic substances in their cells and reduce the concentration of nutrients for plants in soil. This event of accumulation of inorganic substance by the microorganisms and making the plants, nutrient-deficient is known as immobilization.

When organic matter is present in soil it is gradually rendered into a uniform, dark coloured amorphous mass by microorganisms, which is designated as humus. Humus serves as a source of energy for the development of various groups of microorganisms. As a result of decomposition  $\text{CO}_2$ ,  $\text{NH}_3$  and other products are given off. Fungi along with the other microbial groups chiefly bacteria and actinomycetes decompose the organic matter in soil and release the nutrients which are locked up in complex form in organic matter. However, the process of decomposition starts when the plants are in senescent stage. After this stage, termites too play a role in physical breaking

of the litter. Thereafter, microorganisms of different groups colonize the substrate depending upon its chemical composition. Thus microbial succession occurs on the decomposing material till it fully disappears in elemental forms. The events of sequential appearance of microorganisms on a substrate with respect to time is called succession. During the course of decomposition, the water-soluble components are metabolized first. Thereafter, cellulose and hemicellulose disappear gradually. The lignins disappear in the last stage of decomposition because these are resistant to decomposition.

## 6.3. Biogeochemical cycle

The major plant nutrients derived from soil are nitrogen, phosphorus and potassium, because these are made biologically available to plants. Biogeochemical cycling associated with microorganisms is very important for the maintenance of soil fertility.

### 6.3.1. Nitrogen cycle

Nitrogen is the highest concentration in the atmosphere. It is also an essential constituent of proteins and chlorophyll found in organisms. The key processes of biogeochemical cycling of nitrogen are nitrogen fixation, ammonification, nitrification and denitrification.

#### i) Nitrogen fixation

The conversion of molecular nitrogen into a nitrogenous compound is known as nitrogen fixation. There are free living and symbiotic microorganisms, which fix nitrogen into proteins. The nitrogen fixing microorganisms are called diazotrophs.

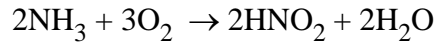
#### ii) Ammonification :

Ammonification is a process in which organic nitrogen is converted to ammonia. The amino acids are utilized as nutrients by microorganisms. Under aerobic conditions, the amino groups are removed from amino acids with the liberation of ammonia.

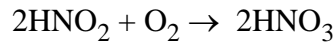
#### iii) Nitrification :

It is a process in which ammonia is oxidized to nitrate. The process consists of two steps. In the first step, ammonia is oxidized to

nitrite. This is called nitrosification.



The oxidation reaction provides energy and this is carried out in the bacterial genera *Nitrosomonas* and *Nitrosococcus*. In the second step, the nitrite is oxidized to nitrate



This oxidation also provides energy and this is carried out in the bacterial genus *Nitrobacter*.

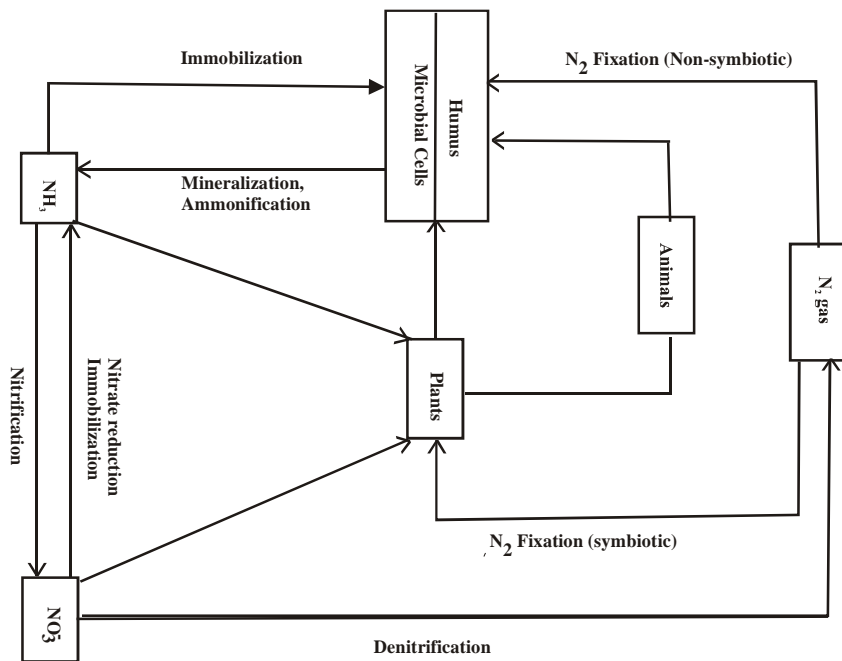
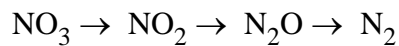


Fig. 6-1. The Nitrogen cycle

iv) **Denitrification :**

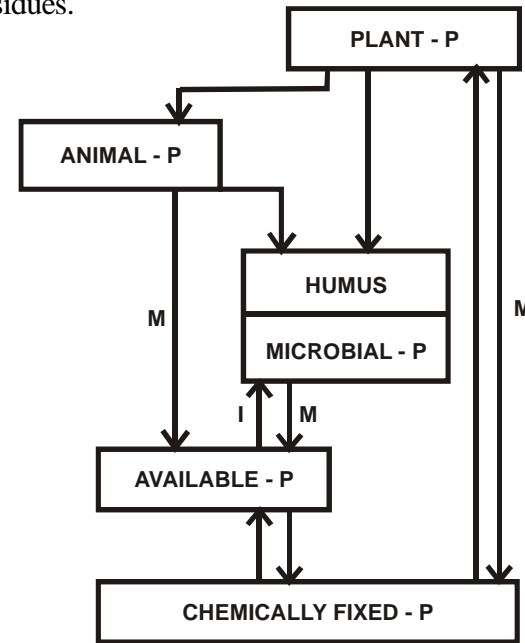
Denitrification is a process in which nitrates are reduced to nitrites and subsequently to gaseous nitrogen.



In denitrification, organic compounds serve as hydrogen donors and nitrate serves as an electron acceptor. Denitrification occurs under anaerobic conditions eg. during seasonal flooding on the land. It is carried out under the influence of bacterial genera like *Thiobacillus denitrificans*, *Micrococcus denitrification* and *Clostridium* sp.

6.3.2. **Phosphorus cycle**

Phosphorus is only second to nitrogen as a mineral nutrient required for plants, animals and microorganisms. It is a major constituent of nucleic acids and in all living systems, it is essential for the accumulation and release of energy. This element is generally added to the soil as a chemical fertilizer or in the form of organic phosphates present in plant residues.



The phosphorous cycle, M - Mineralization, I - Immobilization

Fig. 6-2. Phosphorus cycle

Microorganisms play a key role to bring about a number of transformations of this element. These include (i) altering its solubility, ii)

mineralization of organic phosphate into inorganic phosphate, (iii) oxidation and reduction of phosphorus compounds. Of these mobilization and immobilization are the most important.

The phosphate requirement of plant is met by the uptake of phosphate ions which are then utilized for the synthesis of organic phosphates within the cell. By this, a fraction of the phosphate gets immobilized. Upon the death of the plants, the organic phosphate is rapidly released by enzymatic hydrolysis. In many instances, phosphate becomes limiting factor for plant growth, because much of it in the soil is bound as insoluble calcium, iron or aluminium phosphates.

The availability of phosphates therefore depends on the degree of solubilization of insoluble phosphates by various organic and inorganic acids produced by microorganisms. Several soil microorganisms, particularly fungi are known to produce substantial amounts of these acids and thereby solubilize insoluble phosphates and make it available to the plants. Important microorganisms active in solubilization of inorganic phosphates include both bacteria and fungi such as species of *Bacillus*, *Pseudomonas*, *Micrococcus*, *Aspergillus*, *Penicillium* and *Fusarium*. The enzyme phosphatase plays key role in the solubilization of organic phosphates.

### 6.3.3. The carbon cycle

In nature, carbon exists in the form of inorganic and complex organic compounds. In atmosphere the concentration of  $\text{CO}_2$  is only 0.32 per cent which is less than what is required by plants for photosynthesis.

The  $\text{CO}_2$  is the main source of carbon required to build the organic world. The  $\text{CO}_2$  returns back into the atmosphere through the process of respiration by all groups of organisms. The other method of returning carbon is through degradation (decomposition) of organic matter by microorganisms. A simplified carbon cycle is given in Figure 6.3.

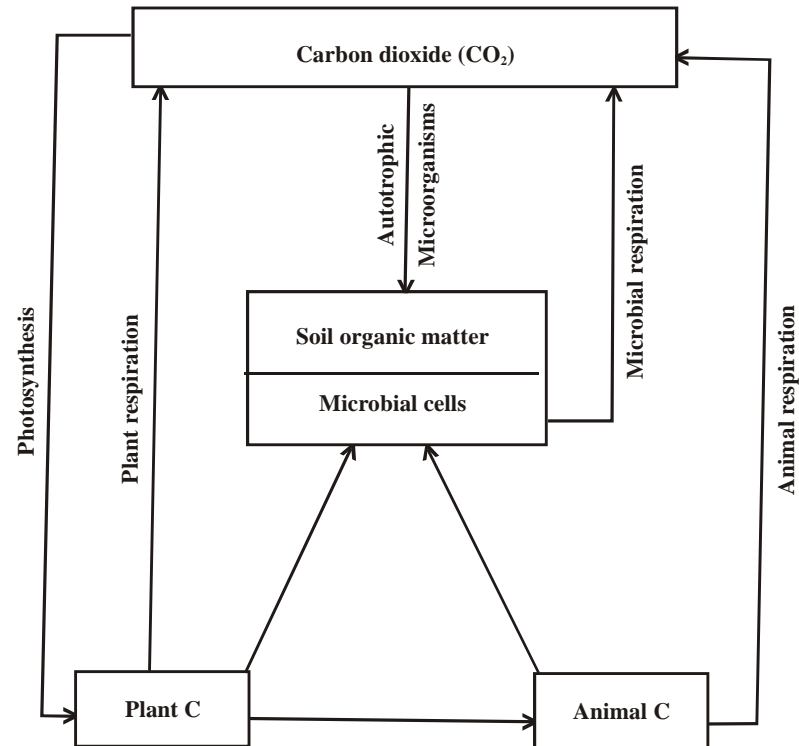
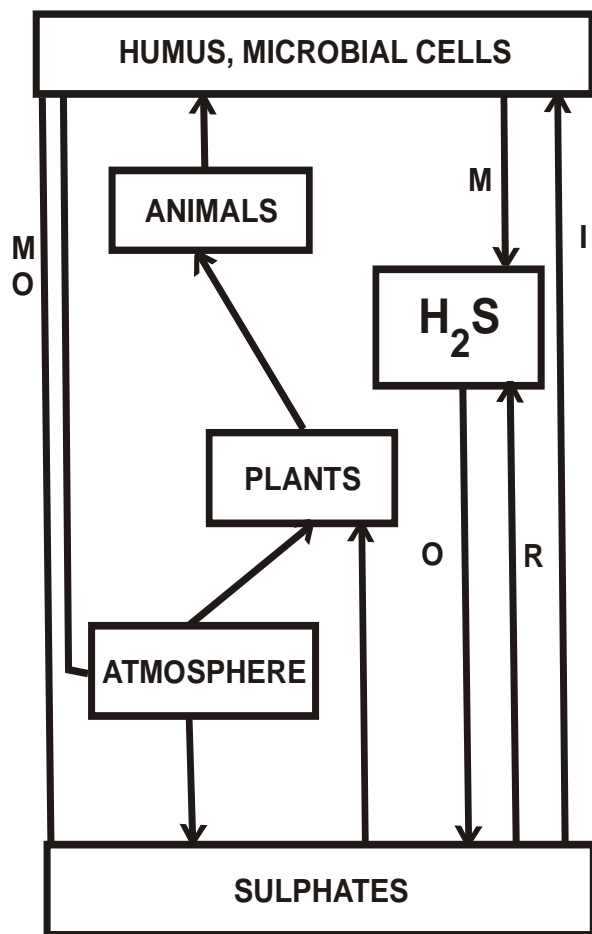


Fig. 6.3 The carbon cycle

### 6.3.4. Sulfur cycle

The cyclic movements of sulfur between the living organisms and the environment are referred as sulfur cycle. Sulfur is an essential element for all living organisms. It is present in free as well as combined states. Plant, animal and microbial proteins, aminoacids - cystine and methionine contain sulphur. In soil, it occurs both in organic (sulfur aminoacids, vitamins, etc.) as well as in the inorganic form (sulfur and sulfates) and is readily metabolized. Four distinct transformations are recognised; these are: (i) decomposition of larger organic sulfur compounds to smaller units and their version into inorganic compounds (mineralization), (ii) microbial associated immobilization, (iii) oxidation of

organic ions and compounds such as sulphides, thiosulphates and sulfur, (iv) reduction of sulphates to sulphides.



The sulphur cycle

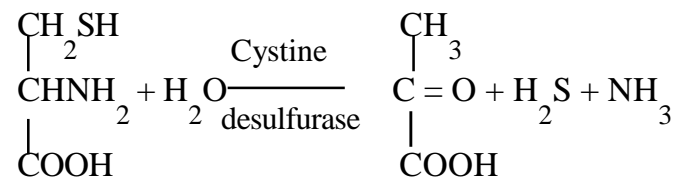
M - Mineralization I - Immobilization, O - Oxidation, R - Reduction,

Fig. 6-4. Sulphur cycle

**i) Decomposition of sulfur compounds :**

Plants obtain their sulfur requirement from sulfur compounds, while animals do so by feeding on plant materials or other animals. In these

systems sulfur is found mostly as a component of sulfur containing aminoacids such as cystine and methionine. The dead organic matter contains large molecules. The decomposers like bacteria, actinomycetes and fungi excrete digestive enzymes. These enzymes convert large molecules into small ones. Sulfur containing aminoacids are converted to inorganic compounds like H<sub>2</sub>S and NH<sub>3</sub>. For example, the aminoacid cysteine releases H<sub>2</sub>S and NH<sub>3</sub> as follows:

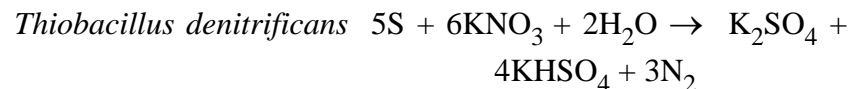


**ii) Microbial associated assimilation or immobilization :**

Many compounds serve as sulfur sources for microbial assimilation. Sulphur is present in inorganic and organic sources. Whatever its sources, sulfur in its elemental form cannot be utilized by plants and animals. Sulfur in soluble form, mostly as SO<sub>4</sub>, is absorbed through plant roots. In the plants SO<sub>4</sub> is incorporated into aminoacids and then to proteins. Plants utilize sulfur in the form of sulphates and then reduce it within the cells to H<sub>2</sub>S before it is utilized mainly in the synthesis of sulfur aminoacids and vitamins.

**iii) Oxidation of sulfur compounds :**

Some microorganisms oxidize reduced sulfur compounds. They are known as sulfur oxidizers. Members of the genus *Thiobacillus* are the main organisms involved in the oxidation of elemental sulfur. The following reactions are catalysed by some of the thiobacilli.

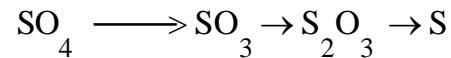


The ability to oxidize sulphur is not restricted to only the genus

*Thiobacillus*. Heterotrophic bacteria, actinomycetes, and fungi are also able to oxidize sulphur compounds. Sulfur is first converted enzymatically to sulphite, which is then oxidized to sulphate.

### Reduction of sulfur compounds

Under anaerobic conditions, sulfate is reduced to H<sub>2</sub>S by sulfate reducing bacteria. The inorganic compounds are reduced by bacteria, called sulfate reducing bacteria. Among the bacteria, *Desulfovibrio desulfuricans* seems to be the most important. The mechanism by which sulfate is reduced involves the conversion of sulphate to sulphite, a reaction that needs ATP. The sulphite is reduced to H<sub>2</sub>S.



## 6.4. Biofertilizer

### i) Definition :

Biofertilizers can be defined as microbial inoculants which are living or latent cells of efficient strains of microorganisms like BGA - Blue green algae, *Azolla*, *Rhizobium*, *Azotobacter* etc. capable of fixing atmospheric nitrogen in a form which can be utilized by the crop plants.

### ii) Importance of biofertilizers :

The increasing cost of nitrogen fertilizers and widening gap between supply and demand of nitrogen in the developing countries have placed heavy constraints on the farmers. A possible solution to tide over the situation is the maximum exploitation of natural biological Nitrogen fixing system, i.e. use of biofertilizers.

### iii) Role of biofertilizers :

Biofertilizers are not substitutes, for fertilizer nitrogen but only supplements. Besides fixing nitrogen they produce antifungal metabolites, certain vitamins, and growth promoting substances, which may increase seed germination, plant stand and improve the initial vigour of the plant, which ultimately contribute to increased yield.

### 6.4.1. Bacterial biofertilizers

Bacterial biofertilizers are *Rhizobium*, *Azotobacter*, *Azospirillum*, *Acetobacter* and Phosphobacteria. *Rhizobium*, *Azorhizobium* are symbiotic nitrogen fixing bacteria. *Azospirillum* is an example for associative symbiotic nitrogen fixing bacterium. *Azotobacter* is an example for non-symbiotic nitrogen fixing bacterium. Phosphobacteria play a vital role in solubilizing rock phosphates. They are called phosphatic solubilizing bacteria eg. *Bacillus megaterium* and *Pseudomonas striata*.

### 6.4.2. Blue green algae (Cyanobacteria)

The nitrogen fixing blue green algae are cultured in open air tanks and fields. The blue green algal biofertilizer is highly suitable for the paddy crop. The paddy field environment provides suitable conditions for the growth and multiplication of blue green algae. BGA play vital role in nitrogen fixation. In addition to nitrogen fixation, BGA provide growth promoting substances, like vitamins and indole acetic acid and gibberellic acid. BGA improve the soil fertility and maintain soil pH. The common blue green algal genera are *Anabaena*, *Nostoc*, *Aulosira*, *Tolypothrix*, *Lingbya*, *Oscillatoria* and *Spirulina maxima*. BGA are applied at the rate of 4 kg / acre of rice field.

#### 6.4.2.1. *Azolla*

*Azolla* is a genus of small aquatic fern that is native to Asia, Africa and America. *Azolla* species live in lakes, ponds, swamps and streams and small bodies of water. *Azolla* is principally used as nitrogenous fertilizer in rice fields, especially in China and Vietnam. They describe *Azolla* as a miniature of nitrogen fertilizer factory. *Azolla* is free floating aquatic fern, which has symbiosis with *Anabaena azollae*, a nitrogen fixing cyanobacterium, and which, by virtue of this property is suitable for use as a green manure. *Azolla* consists of sporophyte with floating rhizome and small overlapping bilobed leaves and roots. The symbiotic association between the eucaryotic water fern and its procaryotic cyanobacterial symbiont *Anabaena azollae* has received much attention, because of its ability to fix atmospheric nitrogen and contribute significant amount of nitrogen to rice crop. *Azolla* produces



20-25 tonnes of fresh biomass per hectare in a short period of 3-4 weeks. It is grown as monocropping and intercropping in rice field. *Azolla* could contribute 40-50 kg of N/ha per rice crop. The use of chemical nitrogenous fertilizer can be minimized by the utilization of efficient and potential nitrogen fixing *Azolla*. The *Azolla* genus belongs to the class Filicopsida, order - Salviniales, Family - Azollaceae. There are eight species found throughout the world. They are (i) *Azolla pinnata* var. *pinnata*, (ii) *A. pinnata* var. *imbricata*, (iii) *A. microphylla*, (iv) *A. caroliniana*, (v) *A. filiculoides*, (vi) *A. mexicana*, (vii) *A. rubra*, (viii) *A. nilotica*. Among the eight species *A. pinnata* var. *imbricata* and *A. microphylla* are widely distributed in Tamil Nadu.

### 6.4.3. Mycorrhiza

The symbiotic association between certain kinds of fungi and roots of higher plant is known as Mycorrhiza (Fungus roots). It is a distinct morphological structure which develops as a result of mutualistic symbiosis between some specific root-inhabiting fungi and plant roots. Plants which suffer from nutrient scarcity, especially P and N, develop mycorrhiza. Mycorrhiza plays a vital role in the mobilization phosphorus mineral. The use of mycorrhizal fungi has increased its significance due to its multifarious role in plant growth and yield. Mycorrhiza increases mineral absorption by the green plants. The fungus provides certain nutrients to the tree, which in turn provides essential growth substances to the fungus. There are two types of mycorrhiza. (i) Endomycorrhiza and (ii) Ectomycorrhiza. If the fungus grows entirely inside the root tissue between the cells it is known as endomycorrhiza. The ectomycorrhizal fungi include *Amanita*, *Boletus* and *Scleroderma*. The endomycorrhizal fungi include (i) *Glomus mosseae*, (ii) *Glomus fasciculatum* and *Gigaspora margarita*.

### 6.5. Biopesticides

Biopesticides are preparation of chemicals / microbial cells basically from bacteria, fungi and viruses for killing of insect pests. The examples are *Baculo viruses*, *Iridovirus*, *Bacillus thuringiensis*, *B. popilliae*, *B. sphaerius*, *Coelomomyces*, *Entomophthora* and

*Fusarium*. Though several types of microorganisms have been endorsed as potential entomopathogens, a notable success has been achieved only with a few microorganisms. The different pest population can be controlled by microorganisms.

#### Points to remember

1. Understand the objective and principles of food preservation.
2. Know the mechanism of organic matter decomposition.
3. Realize the biogeochemical activities of microorganisms in soil.
4. Understand the role of biofertilizers and biopesticides in agriculture.

## Chapter - 7

# INDUSTRIAL MICROBIOLOGY

### 7.0. Introduction

Industrial microbiology is an important branch of microbiology dealing with those areas of microbiology involving economic aspects, where valuable products are prepared from cheaper, and often disposable, substrates. Therefore, it has become possible for the industrial microbiologist to compete with industrial chemist. For example, fermentative production costs of all antibiotics are appreciably less than the synthetic production costs of the same. The industrial microbiology plays a major role in the conversion of substrate into a desired product by the microbial activity. This is called bioconversion. In some cases, mass production of microbes is required. The microbes useful to the industrial process include bacteria, fungi, viruses, actinomycetes and yeasts. For fermentation industries special strains are isolated and developed from natural sources such as soil and water.

### 7.1. Microbial culture

Microorganisms isolated from sources (soil, water and air) or genetic manipulation are cultured on growth media. The growth media are supplemented with sources of carbon, nitrogen, phosphorus, amino acids in organic salts and trace elements etc, are sterilized and inoculated with specific microorganisms for specific products. Some of the microbial cultures are solid culture, batch culture, continuous culture and fed-batch culture.

a) *Solid culture* : Varying amount of agar with nutrient media gives solid or semi solid phase. For the research purpose, these types of media are used but they are generally avoided for microbial products.

b) *Batch culture* : In batch culture, growth phase of microorganisms passes through many stages. A microbe grows in the medium until the nutrients are exhausted or toxic metabolites secreted by it reach to inhibitory level. From the beginning of inoculation to the end, microbial culture passes through several stages. After inoculation, the microbe takes sometime to acclimatize the new environment. Thus the time taken for adaptation before to come to its active growth known as 'lag phase'. The microorganisms grow luxuriantly till the nutrients are present.

c) *Continuous culture* : A continuous culture is that where a steady exponential phase for growth of culture retards due to depletion of nutrients, rather than by accumulation of toxic products; it is prevented by addition of fresh medium to the fermenter and removal of spent medium and microbes from it as a result of which the exponential phase of culture is prolonged.

d) *Fed-batch culture*: Basically it is the batch culture, which is fed continuously with fresh medium without removal of the original culture medium from the fermenter. It results continuous increase in volume of medium in the fermenter.

#### 7.1.1. Culture development

Natural isolates usually produce commercially important products in very low concentration and therefore every attempt is made to increase the productivity of the chosen organism. Increased yields may be achieved by optimizing the cultural medium and growth conditions, but this approach will be limited by the organism's maximum ability to synthesis the product.

The potential productivity of the organisms is controlled by its genome and, therefore, the genome must be modified to increase the potential yield. The cultural requirements of the modified organisms would then be examined to provide conditions that would fully exploit the increased potential of the culture. Several attempts are made to beneficially change the genome of the improved strain. Thus, the process of strain improvement involves the genetic modification of the organism, followed by reappraisals of its cultural requirements.

### 7.1.2. Strain selection

The most important factor for the success of any fermentation industry is a selection of strain. The selected strain should possess the following characters to achieve the desired product in industry. 1) The strain should be high yielding. 2) It should have stable biochemical characteristics. 3) It should not produce undesirable substances. 4) It should be easily cultivated on large scale by employing cheapest raw materials.

### 7.1.3. Primary screening

Both detection and isolation of high yielding species from the natural source material such as soil, containing a heterogeneous microbial population is called screening. There are two types of screening namely primary and secondary.

Primary screening consists of some elementary tests required to detect and to isolate new microbial species exhibiting the desired property. With antibiotic producers, primary screening programmes serve to remove worthless microorganisms on the basis of relatively simple, fundamental criteria. The important selection criteria are the activity of antibiotics *in vitro*, and possibly *in vivo*, against a small number of most important test organisms. Primary screening is also needed in the case of the useful microbial species. The examples of screening procedures are 1) Crowded plate technique, 2) Auxanography, 3) Enrichment culture technique, (4) Use of an indicator dye.

### 7.1.4. Secondary screening

Secondary screening is strictly essential in any systematic screening programme intended to isolate industrially useful microorganisms, since primary screening merely allows the detection and isolation of microorganisms that possess potentially interesting industrial application. Moreover, primary screening does not provide much information needed in setting up a new fermentation process. Secondary screening helps in detecting really useful microorganisms in fermentation processes. The secondary screening gives answers to many questions that arise during the final sorting out of industrially useful microorganisms. Secondary

screening experiments are conducted on agar plates, in flasks or small fermenters containing liquid media or combination of these approaches. Secondary screening can be qualitative or quantitative in its approach. The qualitative approach, for example, tells in the spectrum or range of microorganisms, which is sensitive to a newly discovered antibiotic. Secondary screening should yield the types of information, which are needed in order to evaluate the true potential of microorganisms for industrial usage. It should determine whether the microorganisms are actually producing new chemical compounds not previously described or, alternatively, for fermentation processes that are already known. Further it should determine whether a more economical process is possible. Secondary screening should reveal whether there are pH, aeration, or other critical requirements associated with particular microorganisms, both for the growth of the microorganisms and for the formation of chemical products.

## 7.2. Strain improvement

It is highly desirable that the industrial fermentation process should be made more and more economical. This largely depends upon the efficiency of the production strain involved in the fermentation process. Therefore, a person interested in starting a fermentation industry or in competing with other industries must procure an efficient strain. Thus it is clear that, the use of a high yielding strain in any fermentation process is the most critical factor. Usually, newly isolated strains obtained by screening techniques are not so efficient as could be used in industrial fermentation processes. Therefore, such strains require improvement, so far as the yield of a particularly desired compound is concerned. This is accomplished by producing the mutant fermentation strains with the help of physical and chemical methods. The strain improvement can be done by *auxotrophic mutants* and *mutants resistant to analogues*. Microbial cultures which have multivalent mechanisms, concerted repression or feed back inhibition may be used for strain improvement.

## 7.3. Preservation of industrially important cultures

The isolation of suitable organisms for a commercial process may

be a long and very expensive process and it is therefore essential that it retains the desirable characteristics that led to its selection. Also, the culture used to initiate industrial fermentation must be viable and free from contamination. Thus, industrial cultures must be stored in such a way as to eliminate genetic change, protect against contamination and retain viability. There are several methods adopted to preserve microbial cultures. They are **storage on agar slopes, storage under liquid nitrogen, dried cultures and lyophilization.**

**i) Storage on agar slopes**

Culture grown on agar slopes may be stored in a refrigerated (5°C) or a deep freezer and subcultured at approximately 6-monthly intervals. The time of subculture may be extended to 1 year if the slopes are covered with sterile medicinal grade mineral oil. This is the simplest and common method of maintaining microbial cultures.

**ii) Storage under liquid nitrogen**

The metabolic activities of microorganisms may be reduced considerably by storage at the very low temperature (-150°C to -196°C) which may be achieved using liquid nitrogen refrigerator. This approach is the most universally applicable of all preservation methods. Fungi, bacteriophage, viruses, algae and yeasts have been successfully preserved in this method.

**iii) Dried cultures**

Dried soil cultures have been used widely for culture preservation particularly for sporulating mycelial organisms. Moist, sterile soil may be inoculated with a culture and incubated for several days for some growth to occur and then allowed to dry at room temperature for approximately 2 weeks. The dry soil may be stored in a dry atmosphere. This technique has been used extensively for the storage of fungal and actinomycetes culture.

**iv) Lyophilization**

Lyophilization or freeze-drying, involves the freezing of a culture

followed by its drying under vacuum, which results in the sublimation of the cell water. The technique involves growing the culture to the maximum stationary phase and resuspending the cells in a protective medium such as serum or sodium glutamate. A few drops of the suspension are transferred to an ampoule, which is then frozen and subjected to a high vacuum until sublimation is complete, after which the ampoule is sealed. The ampoules may be stored in a refrigerator and the cells may remain viable for 10 years or more. Lyophilization is very convenient for service culture collections because, once dried, the cultures need no further attention and the storage equipment is cheap and reliable. By this method, culture can be preserved for a longer period.

Whichever technique is used for the preservation of industrial culture it is essential to be certain of the quality of stocks. Each batch of newly preserved cultures should be routinely checked to ensure their quality.

**7.4. Industrial production of penicillin**

**7.4.1. Introduction**

In 1929, Alexander Fleming first discovered the bacteriostatic principle from a fungus (*Penicillium notatum*) and named it penicillin. He observed that a fungal contaminant prevented the growth of *Staphylococci*, which was later on identified as *Penicillium notatum*.

**7.4.2. Organism used for penicillin production**

The fungus *Penicillium notatum* originally used by Fleming for penicillin production, gave poor result. Moreover, many strains of this fungus were developed which produced more penicillin than the original one. In this context, *Penicillium chrysogenum* was selected for the commercial production of penicillin.

**7.4.3. Raw materials for penicillin production**

Several organic materials such as yeast extract, casein, beef extract, lactose, glucose, starch, corn steep liquor and inorganic salts like

ammonium sulphate, potassium dihydrogen phosphate and  $\text{CaCO}_3$  are used as raw materials for penicillin production. In addition, to increase the yield, ethylamine, vegetable oil, citric acid phenyl acetate are also added to the fermentation medium for the production of penicillin.

#### 7.4.4. Optimum conditions required for penicillin production

Production of antibiotic penicillin is also increased by i) keeping the pH of fermentation medium between 6.8 to 7.4, ii) adding buffering agents eg.  $\text{CaCO}_3$  and phosphate to the medium, iii) keeping the temperature at  $25 \pm 0.5^\circ\text{C}$  during incubation, iv) agitating the culture for aeration in large fermenter.

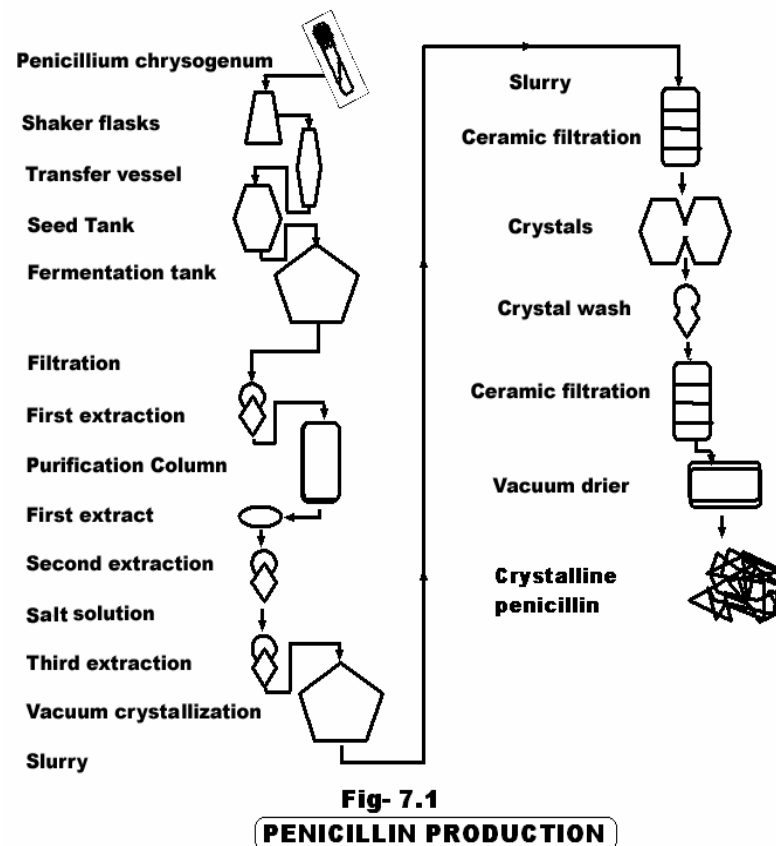
#### 7.4.5. Industrial production of penicillin

Penicillin is produced on large scale in a commercially devised fermenter which provides optimum growth conditions to *Penicillium chrysogenum* for maximum yield.

Following are the steps involved for the production of penicillin.

- i) Inoculate 100 ml medium in 500 ml Erlenmeyer flask with spores of *Penicillium chrysogenum* strain and incubate at  $25^\circ\text{C}$  by keeping them on a rotary shaker.
- ii) After 4 days, transfer the content of flask to another flask (4 litre capacity) containing 2 litres of medium and incubate 2 days.
- iii) Transfer the content to a stainless steel tank (800 litre capacity) containing 500 litres of medium. This tank is equipped in such way that it could provide the optimum conditions for fungal growth.
- iv) After 3 days, use the contents for inoculation of about 1,80,000 litre medium kept in fermenter (2,50,000 liter capacity). The later is equipped with automatic devices to optimum growth conditions.
- v) Filter the content of fermenter after 6 days incubation. Filtrate contains penicillin. Extract the penicillin into

amyl - or butyl acetate. From it transfer penicillin into aqueous solvent by extracting with phosphate buffer. From a butanol water mixture crystallize the potassium penicillin.



### 7.5. Industrial production of organic acids

#### Introduction

Many organic acids such as acetic, lactic, citric, gluconic, itaconic, fumaric etc., are produced by microbial fermentations. The following organic acids are produced by microorganisms.

Acetic acid	- <i>Acetobacter</i> spp.
Lactic acid	- <i>L.delbrukii</i> and other spp.
Citric acid	- <i>Aspergillus niger</i> , <i>A. flavus</i> , <i>A. japonicus</i> <i>A.wentii</i> , <i>Penicillium</i> spp. etc.
Gluconic acid	- <i>A.fumaricus</i> , <i>P. chrysogenum</i> , <i>A. niger</i> , <i>Acetobacter gluconicum</i>
Itaconic acid	- <i>A. terrus</i> , <i>A. itaconicus</i> , <i>A. fumigatus</i> etc.
Fumaric acid	- <i>Penicillium</i> spp., <i>Rhizopus nigricans</i> <i>Mucor</i> sp.

#### Materials required for citric acid production -

Organism	- <i>Aspergillus niger</i>
Carbohydrates sources	- Beet molasses, cane molasses, sucrose, commercial glucose, starch hydrolysates etc.

#### Production of citric acid

Citric acid, which is a key intermediate of the TCA cycle is produced by fungi, yeast and bacteria. The raw material, molasses is diluted to 20-25 per cent sugar concentration and mixed with a nitrogen source and other salts. The pH of the medium is lowered to pH 3.0. The fermentation is carried out either on the surface, submerged, or solid state conditions. In the surface culture method, shallow aluminium or stainless steel pans are filled with the growth medium, inoculated with the fungal spores and allowed to ferment. In the submerged culture method, the mold is cultured in fermenters under vigorous stirring and mixing, while in solid state fermentation, the mold is grown over carrier material such as bagasse, etc. which is impregnated with the fermentation medium.

The production of citric acid by *A. niger* is largely influenced by the concentration of trace metals such as iron, manganese, copper and zinc in the medium. An appropriate concentration of these elements is essential for good acid production. However, excess materials are treated with either ferrocyanide, charcoal, chelating agents or cation

exchange resins. Addition of methanol of 3-4 per cent concentration has been found to enhance the yield of citric acid. The fermentation is an aerobic fermentation and, therefore, adequate aeration is essential for successful citric acid production.

In recent years, the production of citric acid by yeast is gaining importance because many yeasts such as *Candida*, *Hansenula* have been found to produce citric acid from carbohydrates and hydrocarbons. Good yield of citric acid from various raw materials by *Candida lipolytica* has been reported. The mechanism by which these yeasts produce citric acid appears to be slightly different from the mechanism by which the fungi produce citric acid.

After the fermentation is over, calcium citrate is precipitated from the fermented broth by the addition of calcium hydroxide. It is then filtered washed and treated with sulphuric acid to precipitate calcium sulphate. The solution containing citric acid is then purified by treatment with ion exchange resins, charcoal etc and finally crystallized.

#### Uses of citric acid

1. Citric acid is used in food, beverage, textile, pharmaceutical and detergent industries.
2. It is also increasingly used in the removal of toxic and corrosive gases in air.

### 7.6 Wine production

#### Introduction

Wine is produced by the fermentation of fruit juices (traditionally the grape juice) and is a undistilled product of fermentation using a wine yeast such as *Saccharomyces cerevisiae* var. *ellipsoideus*. The yeast ferments the sugars in the juice and produces ethanol and carbon dioxide. The amount of alcohol produced depends on the kind of juice, the yeast strain and the fermentation conditions. Fermentation practices differ from winery to winery and with the type of the wine to be produced.

## Materials required for wine production

Grape fruits, yeast (*Saccharomyces cerevisiae* var. *ellipsoideus*), potassium metabisulphate.

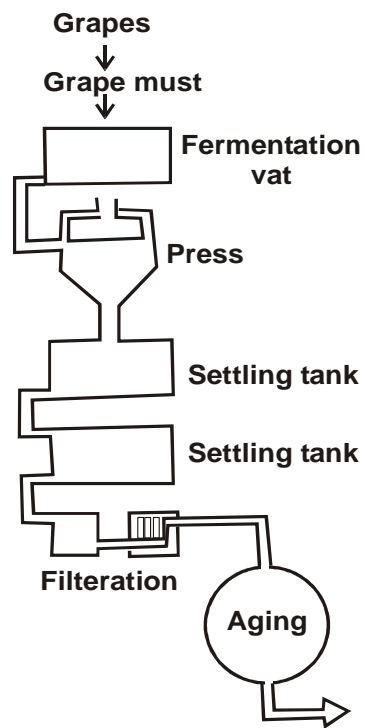


Fig.7.2 Wine Production

## Procedure

Grape fruits are crushed to extract the juice. About 0.250 mg of potassium metabisulphate is added per liter of juice. The starter culture yeast is mixed with the juice at the ratio of 1:10. Fermentation is normally carried out at low temperatures (5-6°C) for 7-11 days or longer and after the fermentation is over, the wine is allowed to settle and later clarified and stored for maturation at low temperatures. During maturation,

the wine undergoes various chemical changes and these changes are responsible for the production of aroma and bouquet. If appropriate preservatives are not used or the conditions of storage are not adequate, acetic acid bacteria can enter and convert the wine into vinegar (acetic fermentation) and water. The different types of wines and their percentage of alcohol are shown in Table III.

Table III. Different types of wines and percentage of alcohol

Class	Percentage of Alcohol
Red wine	11 - 12
White wine	11 - 12
Dessert wine	19 - 21
Appetizer wine	12 - 16
Sparkling wine	11 - 12

## 7.7. Immobilization

The immobilization is 'the imprisonment' of an enzyme in a distinct phase that allows exchange with, but it is separated from the bulk phase in which the substrate, effector or inhibitor molecules are dispersed and monitored. Imprisonment refers to arresting the enzyme by certain means where polymer matrix is formed. The advantages of using immobilized enzymes are i) reuse, ii) continuous use, iii) less labour intensive, iv) saving in capital cost, v) minimum reaction time, vi) less change of contamination in products, vii) more stability, viii) improved process control and ix) high enzyme: substrate ratio.

### Immobilization techniques

There are five different methods of immobilization of enzymes: 1) Adsorption 2) covalent bonding 3) entrapment, 4) copolymerization and 5) encapsulation.

### 1) Adsorption

An enzyme may be immobilized by bonding to either the external or internal surface of a carrier or support such as mineral support, or organic support. Bonds of low energy are involved eg. ionic interactions, hydrogen bonds. If the enzyme is immobilized externally, the carrier particle size must be very small in order to achieve an appreciable surface of bonding. The enzyme immobilized on an internal surface is protected from abrasion, inhibitory bulk solutions and microbial attack and a more stable and active enzyme system may be achieved.

### 2) Covalent bonding

Covalent bonding is formed between the chemical groups of enzymes and chemical groups on the surface of the carrier. Covalent bonding is thus utilized under a broad range of pH, ionic strength and other variable conditions. Immobilization steps are attachment of coupling agent followed by an activation process, or attachment of a functional group and finally attachment of the enzyme.

### 3) Entrapment :

Enzymes can be physically entrapped inside the matrix of a water soluble polymer such as polyacrylamide type gels and naturally derived gels eg. cellulose, triacetate, carrageenan and alginate.

### 4) Cross linking co-polymerization

It is characterized by covalent bonding between the various molecules of an enzyme via a polyfunctional agent such as glutaraldehyde, diazonium salt, and hexa methylene disocyanate. The demerit of using polyfunctional reagents is that they can denature the enzyme. This technique is cheap and simple but not often used with pure proteins, because it produces very little of immobilized enzyme. It is widely used in commercial preparations.

### 5) Encapsulation

It is the enclosing of a droplet of solution in a semipermeable membrane capsule. The capsule is made up of cellulose nitrate and

nylon. The method of encapsulation is cheap and simple but its effectiveness largely depends on the stability of enzyme although catalyst is very effectively retained in the capsule. The technique is restricted to medical science only.

#### Points to remember

1. Know the industrial importance of microorganisms, methods of strain selection.
2. Know the preservation of industrially important culture.
3. Understand the industrial production of penicillin, organic acid and wine.
4. Know the immobilization techniques.



## SECTION - III

### MEDICAL BACTERIOLOGY

#### Chapter - 8.1

#### PATHOGENIC ATTRIBUTES OF BACTERIA

Human body provides many environmental niches that provide food, moisture and warmth necessary for growth of a bacterium. Bacteria possess the genetic capacity to invade, adhere or colonize the human body. They also have the capacity to degrade the tissues with the help of degradative enzyme to get food and escape the host defenses. During their presence in the human body the byproducts of bacterial growth (e.g., acids, gas) cause damage and problems for the human host. Many of these genetic traits are **virulence factors**, which enhance the ability of bacteria to cause disease. Although many bacteria cause disease by directly destroying tissue, some release toxins, which are then disseminated by the blood to cause system-wide pathogenesis. The structures present on the surface of bacteria stimulate host responses (acute phase: interleukin1, interleukin-6, tumor necrosis factor), which can be protective but are often the significant causes of the disease symptoms (e.g., sepsis).

Not all bacteria cause disease, but some always cause disease once infection occurs. The human body is colonized with numerous microbes which live as normal flora, many of which serve important functions for their hosts, such as aiding in the digestion of food, producing vitamins (e.g., vitamin K), and protecting the host from colonization with pathogenic microbes. Many of these endogenous bacterial flora reside in locations such as the gastrointestinal (GI) tract, skin, and upper respiratory tract. Normal flora bacteria cause disease if they enter normally sterile sites of the body. Virulent bacteria have mechanisms that promote their growth in the host at the expense of the host's tissue or organ function. Symptoms result from the damage or loss of tissue or organ function or the development of host inflammatory responses. Opportunistic bacteria cause disease only in People with preexisting conditions that enhance their susceptibility. For example,

*Pseudomonas aeruginosa* infects burn victims and the lungs of patients with cystic fibrosis. Patients with AIDS are highly susceptible to variety of infections particularly to intracellularly growing pathogens like mycobacteria.

The symptoms of a disease are determined by the function of the tissue affected. Along with this systemic responses, produced by toxins, and host defense responses may also occur. The seriousness of the symptoms depends on the importance of the organ affected and the extent of the damage caused by the infection. Infections of the central nervous system are always serious. The bacterial strain and inoculum size are also major factors in determining whether disease occurs or not. This can vary from a relatively small inoculum (e.g., fewer than 200 *Shigella* for shigellosis) to a very large inoculum (e.g.,  $10^8$  to *Vibrio cholerae* or *Campylobacter* organisms for GI tract infections). Host factors can also have a role. For example, although a million or more *Salmonella* organisms are necessary for gastroenteritis to become established in a healthy person, only a few thousand organisms are necessary in a person whose gastric pH is neutral. Congenital defects, immunodeficiency states amid other disease related conditions may also increase a person's susceptibility to infection.

#### Virulence factors

Various factors contribute to bacterial pathogenicity and to be related to the possession of a multiplicity of products and activities referred to as virulence factors.

#### Toxins

It was shown early (1888-90) that certain pathogens, e.g. the diphtheria and tetanus bacilli, formed extracellular toxic materials that reproduced the effects of the disease when injected into animals. Soon the number of such known exotoxins had increased greatly, and streptococci, staphylococci and clostridia were found to produce an array of proteins and enzymes that damaged experimental animals in a variety of ways. Later a number of exotoxins associated with diarrhoeal diseases were discovered. Many pathogenic bacteria did not produce exotoxins but produced cell-bound toxic material, endotoxin, later shown to be a lipopolysaccharide This is now recognized as the main cause of death in a wide range of infections, giving rise to fever, activa-

tion of complement by the alternative pathway, intravascular clotting and the formation of cytokines. The leucocidal action of bacterial exotoxins was demonstrated in staphylococci and subsequently shown to be caused by at least 3 of the exotoxins of *Staphylococcus aureus*. Leucocidins were later described in many other pathogens.

### **Non-toxic determinants of virulence**

Certain substances from bacteria aided the establishment of invasive infection. These were called aggressins. Investigations identified several substances and their ability to act as determinants of virulence. Antisera gave protection against infection with the corresponding organism.

**Capsules:** The capsular polysaccharides of pneumococci and the M proteins of *Streptococcus pyogenes*; both inhibited phagocytosis; whereas the pneumococcal capsule formed a thick mechanical barrier and denied access of complement to the surface of the organism. The M protein formed only a thin surface layer but prevented opsonization. It is now thought to hinder the access of complement by binding fibrinogen to the streptococcal surface. Other pathogens have been found to possess surface components associated with virulence, many of them polysaccharides. These included the K antigens of enterobacteria and the capsular polysaccharides of *Haemophilus influenzae* and *Neisseria meningitidis*. Various actions were attributed to them. In addition to inhibition of phagocytosis, these show antigenic mimicry of host tissue.

The role in pathogenesis of loose extracellular slime not aggregated around individual bacteria has been recognized more recently. Dextrans formed by oral streptococci contribute to the formation of dental plaque. Slime-forming coagulase-negative staphylococci are now believed to initiate the formation of 'vegetations' on prosthetic devices. The alginate slime of mucoid strains of *Pseudomonas aeruginosa* appears to aid colonization of the respiratory tract in cystic fibrosis patients.

### **Adhesins**

As the first stage of the pathogenic process, bacteria adhere to mucous surfaces, such as those of epithelial cells of the respiratory, alimentary and urogenital tracts, with the help of adhesins. **Fimbriae or**

**pili.** Their role in pathogenesis was established when it was shown that adhesion to epithelial cells of the gut was essential for the production and absorption of the enterotoxins of *E. coli*. Other fimbrial colonization factors have since been demonstrated in strains responsible for diarrhoea in various mammals, including humans. Fimbrial adhesins have been described in *gonococci* and *meningococci*. The flagella of the *vibrio cholerae* may also be looked upon as a virulence factor, enabling the organism to penetrate the mucous layer to reach the epithelial surface. Other protein adhesins associated with virulence are found in the outer cell membrane, where they are closely associated with the lipopolysaccharide. This is true of strains of *Shigella* and *Shigella*-like strains of *E. coli* which invade and kill gut epithelial cells. Many of the protein adhesins, whether fimbrial or outer membrane have proved to be encoded on plasmids; indeed this property facilitated their recognition. Adhesion of *S. pyogenes* to pharyngeal epithelial cells is mediated by lipoteichoic acids attached to the cell membrane but protruding to the cell surface and fibronectin is the receptor for these.

### **Antigenic variation**

Some bacteria avoid the host's immune defences by antigenic variation. It was recognized that recrudescences of relapsing fever were associated with reinvasion of the bloodstream by mutant borreliae after the development of an antibody response to the original strain. Gonococci have recently been shown to possess at least 2 mechanisms for altering their surface antigens.

### **Integration of the action of virulence factors**

From the point of view of a micro-organism, pathogenicity is a means of enhancing transmission to fresh hosts and thus the long-term survival of the strain. The ideal virulence factor is not one that leads to the death of the host, but one that maximally enhances and prolongs infectivity. In the simplest of life cycles, a pathogen needs a variety of activities is to be able to enter the host, defeat its immunity mechanisms, multiply, break out of the host again, survive in the world outside, and restart the process; and many life cycles are much more complex than this.

### **Entry into human body**

To establish an infection, bacteria must first gain entry into the

body. Normal defense mechanisms and barriers, such as skin, mucus, ciliated epithelium, and secretions containing antibacterial substances (e.g.; lysozyme), make it difficult for the bacteria to gain entry into the body. Some times these barriers are breached (e.g., a cut in the skin, a tumor or ulcer in the bowel, bullet wound etc), providing portal of entry for the bacteria. Many times bacteria have the means to overcome the barriers and invade the body. On invasion the bacteria can travel in the blood stream to other sites in the body.

### Portal of entry:

#### Ingestion: (GI tract)

Through the mouth and gastro intestinal tract, by ingestion bacteria can enter the body along with food and water. Species of *Salmonella*, *Shigella*, *Vibrio*, *Yersinia*, *Campylobacter*, *Clostridia*, *Listeria*, *Brucella*, *Bacillus* and *E.coli* etc are some of the examples of the bacteria that can enter through GI tract.

#### Inhalation: ( Respiratory tract)

Through nose and respiratory tract many bacteria enter the body and cause diseases. Species of *Mycobacterium*, *Nocardia*, *Mycoplasma*, *Legionella*, *Bordetella*, *Chlamydia*, *Streptococci*, *Haemophilus*, etc enter through respiratory tract. The natural defenses present in the respiratory tract are the mucus, ciliated epithelial cells, and lysozyme in the secretions. The organisms get stuck in the mucus and do not move freely. Ciliary movement of Ciliated epithelial cell pushes the organisms towards the exterior and the lysozyme cleaves the cell wall of gram positive bacteria. However many bacteria are unaffected and possess mechanisms to evade these defenses.

#### Trauma: (Skin)

The skin has a thick horny layer of cells that protects the body from infection. Cuts in the skin produced accidentally or surgically or kept open with catheters or other surgical appliances provide a way for the bacteria to gain access to the susceptible tissues underneath. *Staphylococcus aureus* and *S.epidermidis*, which are part of normal skin flora can enter the body through the break in the skin.

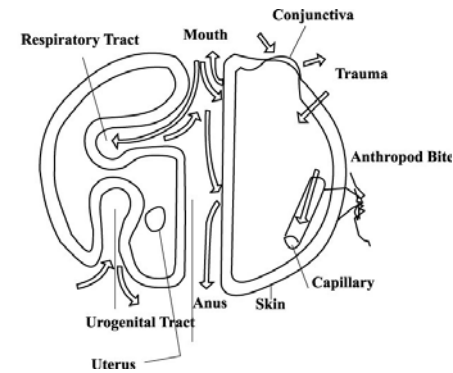


Fig. 8.1.1 Portal of entry of bacteria

**Needle stick :** Through accidental injury with needle and other sharp materials like thorns bacteria can enter the body. *S.aureus*, *Ps.aeruginosa* etc may enter the body through this means.

**Arthropod bite :** Many bacteria enter the body through the bite of an arthropod. For example *Borrelia burgdoferi* is transmitted through the bite of tick, *Borrelia recurrentis* through the bite of lice, *Yersinia pestis* through flea and so on.

**Sexual transmission :** *Neisseria gonorrhoeae*, *Treponema pallidum* and *Chlamydia trachomatis* are some of the organisms transmitted through sexual contact.

**Congenital transmission :** Some organisms get transmitted from the mother to the fetus through the placenta. *Treponema pallidum* gets transmitted from the mother to the fetus and causes congenital syphilis.

#### Points to remember:

1. Bacteria possess various virulence factors which contribute to pathogenicity.
2. They produce different types of toxins such as exotoxin, endotoxin and enterotoxin.
3. Bacteria also possess non-toxic determinants of virulence viz. capsules, slime, pili, flagella etc.
4. They enter the human body through ingestion, inhalation, trauma, insect bites sexual and congenital transmission.

## Chapter - 8.2

### NORMAL FLORA OF THE BODY

Earth teems with life forms with great many varieties and numbers of microorganisms. These life forms have to live together and get their food from different sources. Hence different types of interactions evolved between different life forms. These relationships can be categorized as follows: to life forms living together is called symbiosis. There are three types of symbiotic relationships. 1. commensalism. 2 Mutualism and 3. Parasitism

#### Commensalism:

It is an ideal relationship between two partners because no injury is dealt to either partner by the other. They live, reproduce and carry out full activities unique to each of them. They do not adversely affect each other. Example of medical relevance are the common resident flora present in human body without causing any disease. Some organisms may be present only for a short while and are called transient flora. They find human as inhospitable environment because of various factors like temperature, nutrients, host immune response, and competition from resident flora.

#### Mutualism:

Another interaction between these organisms is mutualism where both partners are benefited by the association. Example: Bacteria present in the intestinal tract synthesize vitamin K which is used by man and the bacteria utilize the food that is supplied.

#### Parasitism:

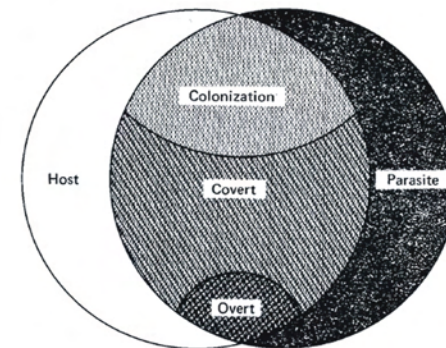
Parasites of primary medical importance are less sophisticated. They have the capacity to injure the host. If the host dies, parasites also are eliminated unless they are transferred to a new host. If the host survives, it eliminates the parasites by defensive means.

As with most biological phenomenon, there is no sharp abrupt distinction, but rather a gradation and a spectrum of parasitic

competence. Some can cause disease if a predisposing condition is present. For example due to penetrating injury if E.coli from the intestine is transferred to urinary tract, it causes urinary tract infection. Some, instead of overt disease, cause covert disease (sub clinical disease) and evoke immune response. Example: Polio viruses. Some produce overt disease, culminating in the virtual elimination of the parasite. Example: Measles virus.

Extreme parasitism is that in which the host is injured too much that the host is eliminated. Example: pneumonic plague caused by *Yersinia pestis*.

Thus the interactions between parasites and the host may lead to colonization, covert or overt disease.



**Fig. 8.2.1** An interaction between host and parasite may result in infection, which consists of colonization and infectious disease. Infectious disease may be either covert (subclinical) or overt (symptomatic).

Normally microorganisms are present on : (1) Skin in general, feet and external auditory canal.(2) Upper respiratory tract including nasal passage and naso pharynx. (3) Mouth including oropharynx, prementulous, saliva, tooth surfaces and gingival crevice. (4). Intestinal

tract (5). Genito urinary tract including external genitalia, anterior urethra and vagina. (6) conjunctiva.

### Types of normal flora:

The normal flora can be broadly classified into two groups: (1) The resident flora which consists of relatively fixed type of microorganisms regularly found in a given area at given age; if disturbed, it promptly reestablishes itself. (2) The transient flora: It consists of non pathogenic or potentially pathogenic organisms that inhabit the skin or mucous membranes for hours, days or weeks. It is derived from the environment, usually does not produce disease and does not establish permanently. If resident flora is disturbed, transient flora may colonize, proliferate and produce disease.

### Normal flora of the mouth and upper respiratory tract

At birth mucous membranes of mouth and pharynx are sterile. But within 4-12 hours viridans streptococci become established. They probably originate in the respiratory tract of mothers and attendants. The following organisms form the most prominent resident flora of nasopharynx.

- (1) any amount of Diphtheroids, Non pathogenic species of Neisseria, *α-hemolytic streptococci*, many species of anaerobic organisms.
- (2) Lesser amounts of Yeasts, Haemophilus species, S.aureus, Gram negative rods, etc

### Normal flora of the intestinal tract:

At birth the intestine is sterile. Organisms are introduced along with the food. In breast-fed children, the intestine contains large numbers of lactic acid Streptococci and lactobacilli. These aerobic and anaerobic gram positive organisms produce acid from carbohydrates and tolerate acid pH (pH:5) As food habits develop toward the adult pattern, the intestinal flora changes. Diet has the pronounced influence on the composition of the intestinal flora.

In normal adults, the esophagus contains organisms of the oral

cavity. Because of the acidity of the stomach very few organisms ( $10^3$  -  $10^5$ /gram of contents) are found through the normal acid pH of the stomach markedly protects against infection with some enteric pathogens like V.cholerae. As the pH of the intestinal contents becomes alkaline, there is an increase in the number of organisms. The following organisms are found in the gastro intestinal tract of man. (1) Various Enterobacteriaceae except Salmonella, Shigella, yersinia, and Vibrio and Campylobacters (2) Non glucose fermenting gram negative rods (3). Enterococci (4) S.epidermidis (5). Alpha and non hemolytic streptococci (6) Diphtheroids (7) S.aureus in small numbers (8) Yeasts in small numbers (9) Large numbers of anaerobic organisms

### Genitourinary tract

Generally the anterior urethra and vagina are the anatomic areas of Genitourinary system permanently colonized with microbes. Urinary bladder may be transiently colonized with bacteria migrating from urethra. But they are quickly cleared by the bactericidal activity of uroepithelial cells and flushing action of voided urine.

### Anterior urethra

A variety of commensal organisms are present in anterior urethra. They are lactobacilli, Streptococci and coagulase negative Staphylococcus. These are relatively avirulent and are rarely associated with human disease. Urethra may be transiently colonized by members of enterobacteriaceae, Enterococcus and Candida. Pathogens such as N.gonorrhoeae and Chlamydia trachomatis cause urethritis and can persist as asymptomatic colonizer of urethra.

### Vagina

The microbial population of the vagina is more diverse and is influenced by hormonal factors. New born girls are colonized by lactobacilli at birth and these predominate for about six weeks. The pH of the vagina is acidic. After this time when the maternal estrogen level declines the pH becomes neutral. The normal flora changes to Staphylococci, Streptococci and members of the Enterobacteriaceae. When the estrogen production is initiated at puberty the pH changes to acidic due the metabolism of carbohydrates especially glycogen. At this time

there is a change in the microbial flora. The lactobacilli predominate once again. Other organisms present are; *S.epidermidis*, Streptococci, Enterococcus, Gardnerella, Mycoplasma, Ureaplasma and variety of anaerobic bacteria. After menopause, the flora changes back to prepubertal flora.

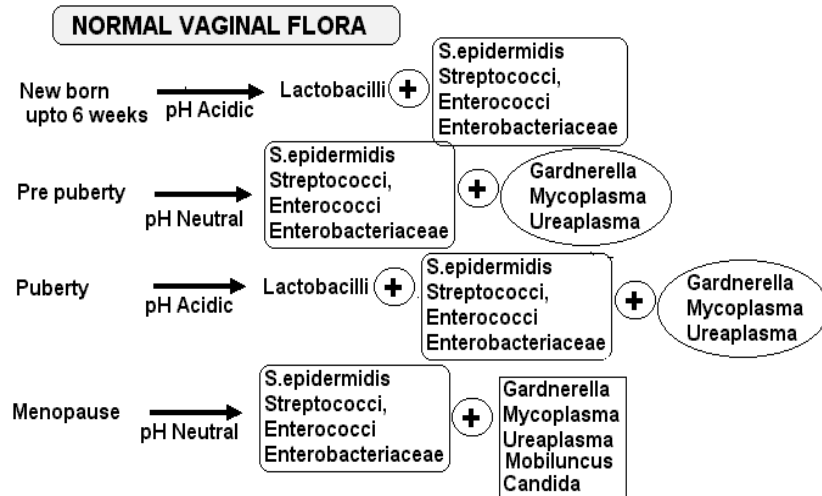


Fig. 8.2.2 Normal Vaginal Flora

### Normal flora of the skin

Because of the constant exposure to environment skin contains transient microorganisms. However, well defined resident flora are present in the skin. The resident flora of the skin varies depending on the anatomic sites where there may be secretions, covered by clothes, or proximity to mucous membranes. The permanent resident flora of the skin are:

*Staphylococcus epidermidis*, *Staphylococcus aureus* (small numbers), Micrococcus species, Non pathogenic Neisseria species, Alpha hemolytic and non hemolytic streptococci, Diphtheroids, Propionibacterium species, Peptostreptococcus species, etc.

Non resident transient flora are eliminated from the skin because of the low pH, fatty acids from sebaceous secretions and presence of lysozyme.

### Role of normal flora:

1. Commensal role: Members of the resident flora of the intestinal tract synthesize vitamin K and aid in the absorption of nutrients.
2. Members of the resident flora prevent colonization by pathogens through bacterial interference. Normal flora compete for nutrients with the incoming pathogens and inhibit the pathogens by producing inhibitory substances like bacteriocins.
3. Members of the normal flora may themselves produce disease under certain circumstances. For example, if they come into normally sterile sites they can initiate a disease. Intestinal bacteria when they reach urinary system, produce urinary tract infection. Similarly oral flora if introduced into blood stream may produce endocarditis.

### Points to remember:

1. Microorganisms live in symbiotic association with man
2. The symbiotic relationships may be either commensalisms or mutualism or parasitism.
3. Body surfaces generally contain microbes that do not cause any harm. They are called normal flora. Normal flora are present in skin, mucous membranes, gastrointestinal tract and genito urinary tract.
4. These normal flora play certain important roles. They are commensals which compete with pathogens for food and ecological niche and prevent the colonization of pathogens. At time these normal flora may also cause a disease if present in an abnormal site.

## Chapter - 8.3

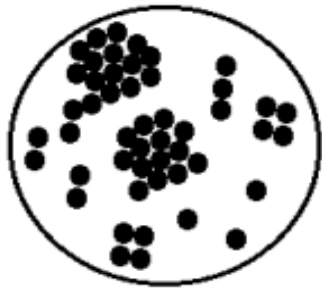
# STAPHYLOCOCCUS AUREUS

### Introduction

Members of the genus *Staphylococcus* belong to the family Micrococcaceae. They are Gram positive cocci that occur in grape-like clusters. The size varies from 0.5-1.5  $\mu\text{m}$  in diameter. They are non motile, non spore forming usually catalase positive and typically noncapsulated.

*Staphylococci* are wide spread in nature. They are mainly found living on the skin, skin glands and mucous membranes of mammals and birds. Generally they have symbiotic relationships with their host. But they become a pathogen if introduced into the tissues through trauma, inoculation by needles or direct implantation of foreign bodies.

At present the genus *Staphylococcus* contains 35 species. Certain species are found frequently as agents of human and animal infections. They are *S.aureus*, *S.epidermidis*, *S.saprophyticus*, *S.haemolyticus* and *S.lugdunensis*. The most important species among them is coagulase positive *S.aureus*.



**Fig. 8.3.1** Staphylococci occur singly and in pairs, tetrads and irregular grape like clusters

### Attributes of *Staphylococcus aureus*

*S.aureus* produces various substances to avoid or overcome host defenses. These substances are enzymes and toxins. They are (1) Cata-

lase: it is an enzyme which splits hydrogen peroxide to water and oxygen. (2) Coagulase : It is an enzyme like protein. It clots plasma, fibrin is deposited over the organism and thus it escapes from the attack by phagocytic cells. (3) Hyaluronidase: it is also called spreading factor. With its help staphylococci can spread through tissues. (4) Staphylokinase : It lyses the fibrin clot. (5) Proteases : These are enzymes that split proteins (6) Lipases : these are enzymes that degrade lipids. (7) Betalactamase: This enzyme is produced by some strains of staphylococci, which splits penicillin molecule (8) Exotoxins: i. Alpha toxin which is a hemolysin that lyses the red blood cell and damages the platelets ii Betatoxin degrades sphingomyelin and damages many cells. (9) Leukocidins: these toxins kill white blood cells. (10) Exfoliative toxin: It causes the peeling off of squamous epithelial cells of skin. This toxin is responsible for a condition called scaled skin syndrome (11) Toxic shock syndrome toxin (TSS toxin): It is associated with fever, shock and multisystem involvement. (12) Enterotoxins: These are responsible for causing food poisoning.

### Staphylococcal infections

People susceptible to staphylococcal infections include newborns, people with chronic diseases such as lung disease, diabetes and cancer, those with skin conditions and surgical incisions and radiation therapy and those with immunosuppressive drugs and anti cancer treatments. *S.aureus* infections are acute and pyogenic. If the infection is not treated, it may spread to surrounding tissue and through blood to other organs. Some of the infections caused by *S.aureus*: (1) involving skin are: (a) furuncles or boils, (b) cellulitis, (c) impetigo (d) and post operative wound infections of various sites. (2) involving other organs are: (i) pneumonia, (ii) bacteraemia, (iii) osteomyelitis (iv) acute endocarditis (v) myocarditis (vi) pericarditis (vii) cerebritis (vii) meningitis (viii) abscess of muscles (ix) scalded skin syndrome (x) urogenital tract (xi) central nervous system and (xii) various intra abdominal organs. (3) Enterotoxigenic strains of *S.aureus* may cause food poisoning. The most common symptoms of Staphylococcal food poisoning include vomiting and diarrhea, which occur 2-4 hours after the ingestion of food containing the toxin.

(4) Toxic Shock Syndrome (TSS) has also been attributed to infection with *S.aureus*.

### **Symptoms:**

As Staphylococci can infect any site in the body, the symptoms depend on the location of the infection. The infection may be mild or life threatening. Commonly, staphylococcal infections produce pus-filled pockets, such as abscesses and boils (furuncles and carbuncles). When Staphylococci infect the skin, abscesses appear as warm, pus-filled pockets below the surface of the skin. They usually rupture like a large pimple and ooze pus onto the skin. Staphylococci can also cause cellulitis, a spreading infection under the skin. Two serious staphylococcal skin infections are toxic epidermal necrolysis and the scalded skin syndrome, both of which lead to large-scale peeling of skin.

*Staphylococcal pneumonia* is a severe infection. People with chronic lung diseases such as chronic bronchitis and emphysema and those with influenza are particularly at risk. Staphylococcal pneumonia often causes high fever and severe lung symptoms such as shortness of breath, rapid breathing, and cough productive of sputum that may be tinged with blood. *Staphylococcal pneumonia* may cause lung abscesses and infection of the pleura and the membrane layers surrounding the lungs. Staphylococci can travel through blood and cause abscesses in internal organs, such as bones (osteomyelitis) and the inner lining of the heart and its valves (endocarditis).

*Staphylococcal bacteraemia* often develops from a staphylococcal infection elsewhere in the body. It usually comes from an infected intravenous device, such as a catheter, which gives staphylococci direct access to the blood stream. *Staphylococcal bacteraemia* is a common cause of death in severely burnt people. Typically, the bacteraemia causes a persistent high fever and sometimes shock.

Bone infections (osteomyelitis) affect those with deep skin ulcers like bedsores. Bone infections cause chills, fever, and bone pain. Redness and swelling appear over the infected bone, and fluid may build up in joints near the areas invaded by the bacteria. The site of infection may be painful, and the person usually has fever.

Surgery increases the risk of staphylococcal infection. The infection may produce abscesses at the stitches or may cause extensive destruction of the incision site. A postoperative staphylococcal infection may worsen and progress to toxic shock syndrome.

### **Epidemiology**

#### **Sources of infection**

1. **Infected lesions:** Large numbers of viable staphylococci are shed in the environment through pus and dried exudates from the infected wound, burns, skin lesions and sputum of bronchopneumonia patients.

2. **Healthy carriers:** Without doing any harm, Staphylococci can grow on moist skin and nostrils of many healthy persons. From these sites organisms are shed into the environment.

3. **Animals:** *Staphylococci* get disseminated from the animals and may cause infections in human. For example, milk from a dairy cow with mastitis may be contaminated with enterotoxigenic staphylococci and later may cause food poisoning.

#### **Mode of transmission:**

Direct contact with the infected and contaminated material is an important mode of spread. Air borne dissemination may also occur. Cross infection is an important method of spread of Staphylococci in hospitals and scrupulous hand washing is essential in preventing infections. Food handlers may introduce enterotoxin producing strains into food. New born babies acquire staphylococci from their mother, nurse or environment. Nursing mothers may get the staphylococci from babies and develop mastitis.

#### **Laboratory diagnosis:**

##### **Specimens:**

One or more of the following specimens are collected aseptically in sterile containers for the diagnosis. (1) pus from furuncles, boils, abscesses, wounds, burns, etc may be collected. Alternatively sterile swabs soaked in pus may be collected. (2) sputum from cases of lower respiratory infections, viz. pneumonia. Sputum should not contain saliva from



mouth. (3) Blood from patients with suspected bacteraemia e.g. in osteomyelitis and endocarditis: 5 ml blood collected aseptically into bottle containing 50 ml of broth. (4) Faeces or vomit from patients with suspected food poisoning. (5) urine from patients with suspected cystitis (infection of the bladder), pyelonephritis (infection of the kidney), or post catheterization infection. (6) anterior nasal and perianal swabs from suspected carriers.

#### **Direct examinations:**

A smear is made from the specimens and examined for the presence of Gram positive cocci in clusters after Gram's staining.

#### **Culture:**

Specimens are inoculated on to plates of nutrient, blood or milk agar and incubated at 37°C for 24 hours. The plates are examined for characteristic golden, cream colored or white colonies. Smears are made from the colonies, Gram stained and checked for gram positive cocci in clusters. On blood agar plates *S.aureus* produces beta hemolytic colonies

#### **Test for identification**

Pathogenic *Staphylococcus aureus* has the ability to clot plasma with the production of coagulase. Two different coagulase tests can be performed: a tube test for free coagulase and a slide test for bound coagulase or clumping factor. This is the most important test to differentiate *S.aureus* from other *Staphylococci* isolated from human sources. *S.aureus* is also positive for catalase, phosphatase, and thermo stable nucleases. It also ferments mannitol without gas production

#### **Antibiotic sensitivity testing:**

The susceptibility of the isolated strains to various antibiotics is determined by disc diffusion method on Muller Hinton agar plates. Nosocomial infections (hospital infections) caused by methicillin resistant *S.aureus* (MRSA) pose a serious problem to health care institutions.

#### **Treatment:**

*Staphylococcus aureus* is inherently sensitive to many antimicrobial agents.

The most active agent is benzyl penicillin, but more than 90% of the strains found in hospitals are resistant to penicillin because they produce beta lactamase enzyme which splits the beta lactam ring in penicillin. Antibiotic resistance arises by various mechanisms. Methicillin resistant *S.aureus* (MRSA) strains pose a big challenge to both therapy and infection control. These MRSA strains are resistant to all beta lactam antibiotics and other agents. Either vancomycin or teichoplanin, is the drug of choice for treatment. After an antibiotic sensitivity testing appropriate drug must be used for treatment.

#### **Points to remember:**

1. *S.aureus* occurs as Gram positive cocci in grape like clusters
2. It produces various enzymes and toxins to overcome host defenses
3. Catalases, coagulase, hyaluronidase, Staphylokinase, lipases and betalactamases are some of the enzymes produced by *S.aureus*
4. Exotoxins, leukocidins, exfoliative toxin, TSS toxin, and enterotoxin are some of the toxins produced by *S.aureus*
5. The infections caused by *S.aureus* are: furuncles, cellulitis, post operative wound infections, *pneumonia*, *bacteremia*, *osteomyelitis*, *meningitis*, *muscle abscess*, *Scalded skin syndrome*, TSS etc
6. Infected lesions, healthy carriers and animals act as sources of infection for *S.aureus*
7. *S.aureus* can be grown in the laboratory on blood agar plates where it produces beta hemolytic colonies and can be identified by coagulase test.
8. MRSA pose a serious problem to health care institutions
9. After a sensitivity testing appropriate antibiotic must be used for treatment.

## Chapter - 8.4

# STREPTOCOCCUS PYOGENES

### Introduction

All Streptococci that are associated with human infections belong to the genera Streptococcus and Enterococcus. *Streptococci* are gram positive cocci which grow as chain and pairs. (Greek: Streptos=chain, coccus= berry). Streptococci are catalase negative, non motile and non spore forming. They are facultative anaerobes, ferment carbohydrates with production of lactic acid.

### Hemolytic activities

Streptococci show various types of haemolysis around the colonies when grown on blood agar plates.

### Alpha haemolysis:

When there is partial clearing of blood around the colonies with greenish discoloration and the out line of RBC is intact, the haemolysis is called alpha haemolysis. *Str.pneumoniae*, *Str.mitis*, *Str.oralis* and *Str.anginosus* show  $\alpha$  haemolysis. Alpha haemolysis is not due to toxin. It is due to the oxidative action of  $H_2O_2$  on haemoglobin to green methaemoglobin.

### Beta haemolysis:

When a zone of complete clearing of blood around the colonies due to lysis of red blood cells is produced, it is called beta haemolysis. It is due to the production of toxin. *Str.pyogenes*, *Str.agalactiae* and *Str.equisimilis* produce  $\beta$  haemolysis.

### Gamma haemolysis:

When no change in the medium around the colony or discoloration and no lysis of red blood cells occur, it is called gamma haemolysis. *Str.salivarius* and *Str.mutans* produce no haemolysis.

### Classification

The genus streptococcus contains important human pathogens and commensals of mucous membranes. The genus includes nearly 40 species. It is divided into six groups based on pathogenicity and other characteristics. (1) The pyogenic group contains important species that are human and animal pathogens like *Str.pyogenes*, *Str.agalactiae* and *Str.equisimilis*. (2) The mitis group contains commensals of the human oral cavity and pharynx. *Str.pneumoniae* belonging to this group is a pathogen. (3) The anginosus group contains *Str.anginosus* which is present as normal flora of oral cavity of man. (4) The salivarius group forms part of normal flora of oral cavity of man that includes *Str.salivarius*. (5) The bovis group is present in the colon of man. (6) The mutans group colonizes the tooth surfaces of man and animals. These are involved in the development of dental caries

### Lancefield grouping:

Based on the major antigenic differences in the polysaccharide of Streptococci, Rebecca Lancefield introduced a serological classification of streptococci. The polysaccharide is called group polysaccharide and identifies different group of streptococci, designated as Lancefield group A,B,C,D etc.

### Characteristics of Streptococcus pyogenes:

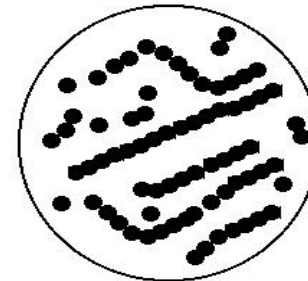


Fig. 8.4-1 Streptococcus pyogenes

### Pathogenic

Streptococcus pyogenes expresses large numbers of virulent factors and induces varying clinical conditions. These virulence factors help

the organisms to adhere to tissues, evade host defenses and cause tissue damage. All virulence factors may not be expressed by all strains all the times. Hence there is variation seen in clinical picture. The following schematic diagram shows the location of various virulence associated products of *Str. pyogenes*.

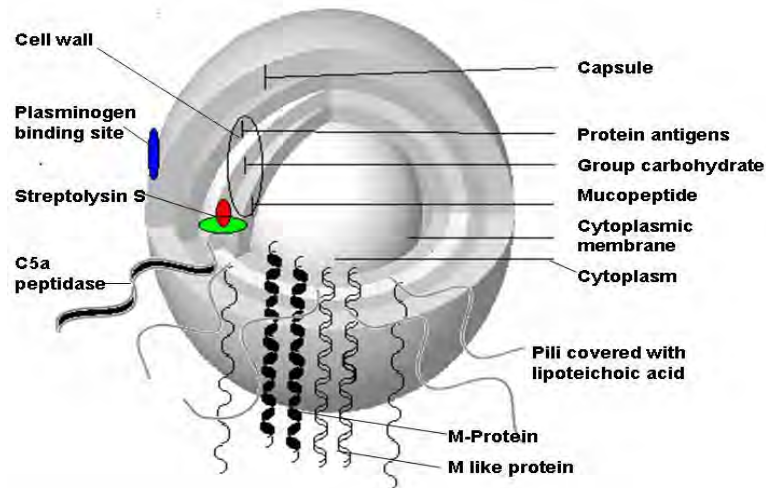


Fig. 8.4-2 Streptococcus pyogenes

#### Adhesion:

Host cells contain a matrix protein called fibronectin. *Str. pyogenes* possesses a protein called F protein. There is interaction between host cell fibronectin and streptococcal F protein. This leads to initial binding and later internalization of streptococci into the host cell.

#### M proteins:

The M protein is anchored in the cytoplasmic membrane. It comes out through the cell wall and protrudes from the cell surface as fibrils. It helps the organisms to adhere on to the host cells and resist phagocytosis. Antibodies to M proteins give acquired resistance to streptococci possessing that specific M protein. However, there are many different kinds of M protein variants. More than 80 different M proteins have been identified. Hence a person may suffer from recurrent *Streptococ-*

*cus pyogenes* infection with strains expressing different versions of M protein.

#### M like protein:

M like protein is structurally related to M protein. It has anti-phagocytic activity. It can bind various serum proteins which include fibrinogen, plasminogen, albumin, IgG, IgA  $\alpha$ 2 macroglobulin, factor H of complement system. As these bacteria are coated with host proteins, they camouflage themselves and evade host defenses.

#### Capsule:

Some strains of *Str. pyogenes* produce capsule. This capsule is made up of hyaluronic acid. Capsule producing strains are highly virulent. Capsule has anti-phagocytic activity. Because the capsule is identical with the hyaluronic acid of connective tissue of the host, the bacteria disguise themselves and avoid immune attack.

#### Enzymes:

##### C5a peptidase:

C5a is a component of complement system generated during complement activation. C5a is a chemotactic agent that attracts phagocytic cells. C5a peptidase is an enzyme produced by *Str. pyogenes*. It cleaves the C5a and inactivates it so that phagocytic cells are not attracted.

##### Hyaluronidase:

*Str. pyogenes* produces an enzyme called hyaluronidase. It degrades hyaluronic acid, which is a cement substance present in connective tissues. This facilitates spread of infection in tissues.

##### Streptokinase:

Streptokinase is also called fibrinolysin. It helps in the rapid spread of organisms in the tissues. It is produced by all strains of *Str. pyogenes*. It activates plasminogen into plasmin. *Str. pyogenes* employs host plasmin to hinder fibrin barrier formation and thus spreads rapidly.

### **Lipoproteinase:**

This enzyme is called opacity factor. It induces opalescence in growth media containing serum. It is produced mainly by *Str. pyogenes* causing skin infections.

### **Deoxyribonuclease: (DNase)**

Four different forms of DNases are produced by *Str. pyogenes*. They are designated DNase A, B, C and D. These enzymes hydrolyze deoxyribonucleic acid. They play a role in spreading by liquefying viscous exudates.

### **Toxins:**

Streptolysins: *Str. pyogenes* produces two different kinds of streptolysins. One is oxygen labile streptolysin O and the other is serum soluble streptolysin S. Both these streptolysins lyse red blood cells.

### **Pathogenesis and clinical findings:**

In streptococcal infections a variety of distinct disease processes are seen. The outcome of infection and the diseases depend on the properties of the infecting organisms, the portal of entry and the host response. Infections can be divided into different categories.

### **Streptococcal diseases:**

#### **1. Non invasive Streptococcal disease**

A. The most common infections caused by *Str. pyogenes* are relatively mild and non invasive infections of the upper respiratory tract (pharyngitis) and skin (impetigo).

##### **a. Pharyngitis:**

The most common infection of *Str. pyogenes* is pharyngitis. Abrupt onset of sore throat, fever, malaise, and head ache which are the clinical signs that develop 2-4 days after the exposure. The posterior pharynx is affected. The tonsil is enlarged with grey-white exudates on its surface. Because of the local inflammation cervical lymph nodes enlarge. Occasionally tonsillar abscess develops.

##### **b. Scarlet fever:**

Certain strains of *Str. pyogenes* produce pyrogenic exotoxin. When these strains cause infections, a diffuse erythematous rash develops over skin and mucous membranes. This condition is called scarlet fever or scarlatina. The rash develops 1-2 days after the first symptoms of pharyngitis. Initially it develops on the upper chest and then spreads to the extremities.

##### **c. Skin infections:**

###### **i. Impetigo or pyoderma:**

*Str. pyogenes* may cause many types of skin infections. Impetigo is a superficial and localized skin infection. It occurs mainly in children. It affects exposed areas of face, arms and legs. Initially clear vesicles develop which are within few days filled with pus. Secondary spread is seen as the result of scratching.

###### **ii. Erysipelas (cellulitis):**

It is an acute infection that occurs in the superficial layers of the skin. The infection is characterized by diffuse redness of skin, local pain, enlargement of regional lymph nodes and fever. If not treated promptly, it may spread to blood stream and may be fatal.

#### **2. Invasive soft tissue infection**

Some times *Str. pyogenes* enters internal body structures and establishes severe invasive infections. Necrotizing fasciitis, streptococcal toxic shock syndrome and puerperal fever are some of the infections associated with bacteraemia.

##### **i. Necrotizing fasciitis:**

In this infection, rapid destruction of fat and fascia occurs. *Str. pyogenes* enters these tissues through skin after minor trauma. But skin may show minimal signs of infection. Systemic shock and general deterioration occur very fast. It affects both immunocompetent and immunosuppressed individuals. Streptococci can be isolated from the blood, blister fluid and culture of infected areas.

**ii. Streptococcal toxic shock syndrome:**

Streptococcal toxic shock syndrome is an acute fulminating disease which may develop in patients with necrotizing fasciitis, or with invasive bacteraemic streptococcal infections. The disease occurs due to the release of toxins in the blood. The clinical signs resemble staphylococcal TSS. Fever, malaise, nausea, vomiting, and diarrhea, dizziness, confusion and a flat rash over large parts of the body may also be present

**iii. Puerperal sepsis:**

If the streptococci enter the uterus after delivery, puerperal fever develops. Streptococci from the endometrium enter the blood and cause septicemia. After the introduction of antibiotic therapy this condition occurs rarely.

**3. Non suppurative sequelae or post streptococcal diseases:**

Two serious diseases may develop as sequelae to *Str. pyogenes* infections. Following an acute *Str. pyogenes* infection, there is a latent period of 1-4 weeks. After this period occasionally nephritis or rheumatic fever develops. These conditions are not due to the direct effect of the organisms, but due to hypersensitivity response. Nephritis is more common after skin infections. Rheumatic heart disease is common after respiratory infections.

**a. Acute glomerulonephritis (AGN):**

This condition develops 3 weeks after streptococcal infections. It is associated with certain M antigenic types particularly M types 2,4,12,49. Some strains are nephritogenic. Glomerulonephritis may be initiated by antigen-antibody complexes on the glomerular basement membrane. In acute nephritis, there is blood and protein in the urine. Oedema, high blood pressure, and urea nitrogen retention are also seen. Serum complement levels are low. Few patients may die. Some develop chronic glomerulonephritis with ultimate kidney failure. The majority of the patients recover completely.

**b. Rheumatic fever:**

Rheumatic fever is a major cause of acquired heart disease in young people. It is a condition in which inflammation of joints (arthritis),

heart (Carditis), central nervous system (Chorea), skin (erythema marginatum) and/or subcutaneous nodules occur. Polyarticular arthritis is the most common manifestation. Carditis is a most serious condition because it leads to permanent damage to heart valves. Rheumatic fever is autoimmune in nature. Theories to explain the pathogenesis of rheumatic fever have focused on tissue damage caused by streptococcal products (i.e. streptolysins), or antigen-antibody complexes (as in serum sickness). Recently it is proposed that rheumatic fever may be due to molecular mimicry and autoimmunity.

Various streptococcal cellular components have been shown to mimic the structure of molecules found in human tissue. Antibodies directed against streptococcal products are thought to cross-react with host tissue, producing autoimmune damage. Similarities in structure and subsequent serological cross-reactivity of streptococcal cell constituents (M protein, membrane antigens, group carbohydrate) with human heart, skin, joint and brain tissues have been demonstrated. Patients exhibiting rheumatic fever are found to harbor antibodies that cross-react with both streptococcal products and human tissue components. The major antigens involved are myosin, tropomyosin, laminin and keratin in the human tissues and the group A, *Str. pyogenes* antigen which is polymer of N-acetyl glucosamine. Repeated episodes of *Str. pyogenes* infection increase the severity of the disease

**Epidemiology**

**Pharyngitis and respiratory infections**

Group A streptococci are usually transmitted from person to person, via respiratory or saliva droplets. Epidemics of streptococcal pharyngitis caused by contaminated food or drink have also been documented. Widespread pasteurization has greatly reduced reports of infection by contaminated milk. Contamination of food with infected respiratory secretions are thought to be the most common cause of food borne streptococcal infection, but skin infections of those handling food may also be the ultimate source of contamination. Streptococci present on clothing, bedding or in dust do not seem to contribute to the spread of pharyngitis. Crowded conditions occurring in schools, military

barracks and in indoor environments in cold weather, favour the spread of streptococci.

The occurrence of scarlet fever case parallels the dissemination of pharyngitis-associated, toxin-producing *Str. pyogenes* strains.

### **Acute rheumatic fever and acute glomerulonephritis**

Acute rheumatic fever and acute glomerulonephritis occur as non-suppurative sequelae of infection by *Str. pyogenes*. Rheumatic fever may follow streptococcal pharyngitis but not cutaneous infection, whereas glomerulonephritis is preceded by either skin or throat infection.

### **Laboratory diagnosis of infections with Streptococcus pyogenes:**

#### **Specimens:**

Depending on the site of infection specimens are collected. The specimens include throat swabs or skin swabs, pus, blood, cerebrospinal fluid (CSF).

#### **Cultivation and identification:**

The primary cultivation medium used for streptococci is blood agar. *Str. pyogenes* is detected initially by its  $\beta$ -hemolytic activity. The colonies are 1 mm in diameter and non pigmented. They are catalase negative. Gram's stained smear shows gram positive cocci in chains. *Str. pyogenes* is sensitive to bacitracin (0.4 microgram disc). The species is identified by serological detection of group antigen by immune precipitation or co-agglutination test using specific antiserum.

#### **Antibody detection:**

Antibodies against antigen of *Str. pyogenes* are elevated in post streptococcal sequelae. In rheumatic fever cases antistreptolysin O titer is elevated. Increased levels of serum antibodies to streptococcal hyaluronidase and DNase B are also seen. In acute glomerulonephritis, elevated ASO titer is not observed. But elevated levels of anti-streptococcal DNase B are seen.

### **Treatment:**

*Str. pyogenes* is susceptible to penicillin and a wide range of antibiotics. In case of hypersensitivity to penicillin, erythromycin is usually a second choice. Treatment for 10 days will eliminate streptococci from the infected area. Surgery is essential to remove damaged tissue in case of necrotizing fasciitis because antibiotic penetration of infected areas is poor. In this case clindamycin is preferred over penicillin because it inhibits protein synthesis including exotoxin.

### **Prevention and control:**

Skin infection with *Str. pyogenes* is associated with poor hygiene and can be prevented by standard hygienic measures.

#### **Points to remember:**

1. Streptococci produce different kinds of haemolysis when grown on blood agar. Group A beta haemolytic streptococci are very important as this causes variety of invasive and noninvasive diseases in man.
2. This organism possesses different kinds of pathogenic attributes like surface proteins and enzymes.
3. It produces invasive diseases like pharyngitis, scarlet fever and skin infections and also noninvasive diseases like Acute glomerulonephritis and rheumatic fever.

## Chapter - 8.5

### CORYNEBACTERIUM DIPHTHERIAE

#### Introduction:

The genus *Corynebacterium* contains number of organisms and the major human pathogen is *Corynebacterium diphtheriae*. It also contains harmless saprophytes found frequently on mucous membranes. Diphtheria is an infection of man that spreads directly from person to person. Spread is facilitated by intimate and continuous contact with people harboring the organism. People harbor the organism after an attack of the disease as convalescent carrier. Diphtheria occurs due to the action of a potent toxin elaborated by the causative bacteria *Corynebacterium diphtheriae*. Resistance to the disease depends on the availability of specific neutralizing antitoxin in the blood.

**C. diphtheriae :** It is a slender gram positive rod, non acid fast, non spore forming, 0.5 to 1 $\mu$  in width  $\times$  1.5 to 5 $\mu$  in length. In stained smear individual cells lie at sharp angles to one another in V & L shapes or Chinese letter formation. It is pleomorphic, club shaped, shows beaded forms because of the presence of metachromatic granules.

**Growth characteristics:** It is aerobic, and produces waxy pellicle in liquid medium and minute, greyish white glistening colonies on Loeffler's coagulated serum medium. On Blood agar medium containing tellurite, colonies are grey to black because tellurite is reduced intracellularly into tellurium.

Three types of *C. diphtheriae* have typical appearance. 1. Gravis type produces non hemolytic, large, grey, irregular, striated colonies. 2. Mitis type produces hemolytic, small, black, glossy convex colonies. 3. Intermedius type produces non hemolytic, small colonies between the two.

In Broth Gravis forms a pellicle Mitis grows diffusely and Intermedius settles as a granular settlement.

#### Pathogenesis :

*C. diphtheriae* is present as normal flora in the respiratory tract, wounds and in convalescent carriers. It Spreads from one person to another by droplets, grows on mucous membranes or in skin abrasions. Toxigenic strains produce toxin which is released into the surrounding and absorbed. Toxin has 2 parts, the portion B transports A into the cell. Portion A inactivates EF2 complex and protein synthesis in the cell is stopped. Diphtheria is an acute communicable disease manifested by both local infection of the upper respiratory tract and the systemic effects of a toxin. There are 2 phases of diphtheria, the initial local presentation as a severe pharyngitis. During this time a tough membrane over the air passage is formed and causes suffocation. Later in the systemic phase the circulating exotoxin affects the tissues of the host that are most notable in the heart and peripheral nerves.

**Pathology :** The toxin is absorbed into the mucous membrane leading to the destruction of epithelium and the initiation of inflammatory reaction. Necrotic epithelium becomes embedded in fibrin and red and white cells. A greyish "pseudo-membrane" is formed commonly over tonsils, pharynx or larynx. Any tear in the membrane will cause bleeding.

The bacilli continuously produce toxin inside the membrane. The toxin causes damage, necrosis in the heart muscle, liver, kidneys and adrenals, sometimes accompanied by hemorrhage. The toxin also produces nerve damage resulting in paralysis of the soft palate, eye muscles and muscles of extremities [hands and legs].

#### Clinical manifestations

*C. diphtheriae* is generally not an invasive organism. Clinical manifestations are associated with both the local and systemic effects of the diphtheria toxin. The toxin is responsible for local tissue destruction and formation of the membrane. Diphtheria is classified into several clinical types, depending on the site of the disease .

**(1) Respiratory diphtheria:**

*C. diphtheriae* infects primarily the upper respiratory tract, where the organism colonizes the mucosal surface of the nasopharynx and multiplies locally without bloodstream invasion. Following an incubation period of usually 2-5 days, the illness begins gradually with malaise, sore throat, anorexia and fever.

Locally, toxin induces tissue necrosis, leukocyte response and formation of a tough, adherent pseudomembrane composed of a mixture of fibrin, dead cells and bacteria. The membrane is tightly adherent and bleeding occurs upon attempts to remove it.

**(2) Pharyngeal diphtheria:**

The membrane usually begins to form on the tonsils or posterior pharynx. In more severe cases it can spread progressively over the pharyngeal wall, fauces and the soft palate all the way to the bronchi. This is called pharyngeal diphtheria.

**(3) Laryngeal diphtheria:**

As the membrane spreads the patients may develop significant edema of the submandibular areas and the anterior neck with the lymphadenopathy, giving them a characteristic 'bull neck appearance'. In severe cases the neck edema may extend past the clavicles into the chest, accompanied by the erythema. Laryngeal diphtheria can occur as a result of membrane extension. It presents with hoarseness, stridor and dyspnoea, and airway obstruction.

**(4) Systemic effect ;**

The disease may progress, if enough toxin enters the bloodstream, causing severe prostration, striking pallor, rapid pulse, stupor and coma. These effects may result in death within a week of onset of symptoms. The absorbed toxin can also cause delayed damage at distant sites. The most frequently affected organs are the heart (myocarditis) and the cranial nerves. These complications may occur from 1 to 12 weeks after disease onset.

**(5) Cutaneous diphtheria :**

Cutaneous diphtheria often appears as a secondary infection of a previous wound. Primary cutaneous diphtheria begins as a tender pustule and enlarges to an oval punched-out ulcer with a membrane and edematous rolled borders. Skin infections may vary in severity, but toxin-induced complications are usually uncommon.

**(6) Local infections :**

*C. diphtheriae* may also cause local infections such as vulvovaginitis, conjunctivitis and primary or secondary otitis media.

Asymptomatic nasopharyngeal infection with *C. diphtheriae* is more frequent than clinical disease. The length of carriage averages 10 days, but chronic carriers may shed the organism for 6 months or more. Antibiotic treatment is effective in terminating shedding

**Laboratory diagnosis of Diphtheria:**

**Collection of specimens Culture and identification**

A swab is used to collect specimen from the inflamed areas of the membranes that are formed in the throat and nasopharynx, Nasal swabs are taken to detect carriers. Material from wounds should be removed by swab or aspiration, taking care to avoid normal skin flora. The specimen should be immediately transported to the laboratory or inoculated onto proper media.

Smears can be made of the original material for subsequent Neisser or Loeffler's methylene blue stain for observation of metachromatic granules and gram stain for coryneform morphology.

Specimens for *C. diphtheriae* should be streaked onto a blood agar plate and onto a tellurite-containing medium such as Hoyle's medium, cystine-tellurite agar or modified Tinsdale medium. The tellurite-containing media have the advantage of being both selective and differential; tellurite inhibits the growth of most nasopharyngeal flora and *C. diphtheriae* has a rare ability to reduce tellurite salt to black-colored tellurium, rendering the colonies black.



A Loeffler's serum slant can also be inoculated because *C. diphtheriae* grows most rapidly on this lipid-rich medium. If smears are made and gram stained from colonies grown on Loeffler medium, metachromatic granules can be demonstrated clearly.

After isolation, identification of *C. diphtheriae* is not difficult. Tests that are important to distinguish *C. diphtheriae* from other corynebacteria and coryneform organisms are production of catalase, urease and pyrazinamidase, nitrate reduction, glucose, sucrose, mannose, xylose and maltose fermentation and utilization of starch and glycerol.

### Detection of toxigenicity:

Production of toxin is determined by guinea pig lethality testing in which toxigenic strains when injected into guinea pigs kill the animals in 24 to 48 hours. Another standard in vitro test is Elek's immunoprecipitation assay.

A recent development in the diagnosis of diphtheria is the use of polymerase chain reaction (PCR) to detect the toxin gene. In this PCR test a 0.9 kb segment of the tox gene is amplified.

## PROPHYLAXIS OF DIPHTHERIA

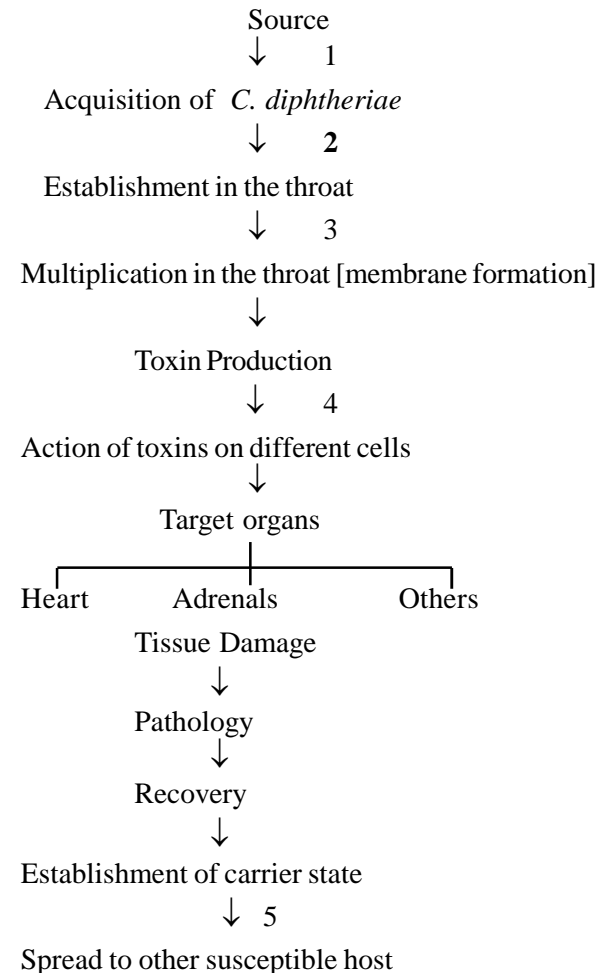
As we had already seen, diphtheria is an infection of man that spreads directly from person to person. Spread is facilitated by intimate and continuous contact with people harboring the organisms. People harbor the organism after an attack of the disease as convalescent carrier.

Diphtheria occurs due to the action of a potent toxin elaborated by the causative bacteria *Corynebacterium diphtheriae*. Resistance to the disease depends on the availability of specific neutralizing anti-toxin in the blood.

### 1, 2. Prevention of spread from source to susceptible host

Source may be an 1) Infected individual 2) Convalescent carrier. One can prevent the infection by avoiding contact with source of infection.

### Points at which prophylaxis can be given



### 3. Prevention of establishment of organism in the susceptible host

Once it is known that the host had a contact with the infected individual or convalescent carrier **chemoprophylaxis** must be given to prevent the establishment of the organisms in the tissues.

#### 4. Prevention of toxin acting on target cells

If it is known that the organism is established in the tissues and toxin production is expected, the damaging effect of toxin is neutralized by **Antitoxin** treatment. Antitoxin is produced in animals [Horses, Rabbits, goat or sheep]. A dose of 20, 000 or 1 lakh units are injected intra-muscularly or intra venously. Hypersensitivity to animal proteins is checked by skin or conjunctival test. Further production of toxin is prevented by treating the patients with antibiotics such as penicillin or erythromycin.

#### 5. Prevention of establishment of carrier state

Patients must be treated with antibiotics so that they do not become carriers of the organisms

#### 6. Immunisation of all children to become immune individuals

Children should be immunized with diphtheria toxoid so that adequate antitoxin will be present in the serum. Toxin is inactivated by formalin to get toxoid. Toxoid is adsorbed onto aluminium hydroxide. It is combined with tetanus toxoid and pertussis vaccine to get DPT

##### IMMUNIZATION SCHEDULE - Schedule for Children

VISIT	AGE IN MONTHS	VACCINE
1	0	BCG
2	2 MONTHS	DPT [1], ORAL POLIO [1]
3	4 MONTHS	DPT [2], ORAL POLIO [1]
4	6 MONTHS	DPT [3], ORAL POLIO [3]
5	9 MONTHS	MMR, ORAL POLIO [4]
6	18 MONTHS	DPT [4], ORAL POLIO [5]
7	SCHOOL ENTRY	TETANUS TOXOID

#### Check for immune status:

By doing a Schick test the immune status of the individual can be ascertained and if needed booster doses of toxoid can be advocated.

#### Points to remember

1. Diphtheria is an infection of man that spreads directly from person to person. Spread is facilitated by intimate and continuous contact with people harboring the organisms. People harbor the organism after an attack of the disease as convalescent carrier.
2. Diphtheria occurs due to the action of a potent toxin elaborated by the causative bacteria *Corynebacterium diphtheriae*.
3. Resistance to the disease depends on the availability of specific neutralizing antitoxin in the blood.
4. Children should be immunized with DPT so that adequate anti toxin is present in the serum.

## Chapter 8.6

### SALMONELLA

Salmonellae belong to the family Enterobacteriaceae. There are over 2000 different antigenic types of Salmonella. They were originally classified as separate species. But now they are kept under a single species called *Salmonella enterica* and there are different sub species recognized. The serotypes that infect mammals are put into a subspecies also designated as enterica. The full correct designation is for example: *Salmonella enterica* subspecies enterica serotype typhi. But this is abbreviated to Salmonella serotype typhi or simply *S.typhi*. ( please note that the serotype name starts with capital letter). Many serotypes are host specific. Organisms causing infections in man may not cause disease in animals and vice versa.

#### Description:

Salmonellae are Gram negative bacilli, motile non spore forming, facultatively anaerobic, nonfastidious, able to grow on relatively simple media. They are distinguished from other members of the family by their biochemical characteristics and antigenic structure. Their normal habitat is animal intestine.

#### Infections due to Salmonella:

Salmonella infections present a spectrum of clinical syndromes; they are: 1. Enteric fever (typhoid and paratyphoid fevers) 2. Acute gastroenteritis, 3. Bacteraemia and 4. Localized infections. In addition salmonellae may cause asymptomatic intestinal infections and convalescent intestinal carrier state.

#### Typhoid fever.

Typhoid fever is an acute systemic disease due to infection with *S. typhi*. It is unique to human characterized by malaise, fever, abdominal discomfort, transient rash, splenomegaly and

leucopenia. Major complications are intestinal haemorrhage and perforation. Classically it is caused by *S.typhi*, but can also be caused by *S.paratyphi A*, *S. paratyphi B* and *S. paratyphi C*; which are called paratyphoid fevers.

#### Epidemiology

Organisms gain access by oral route through contaminated food, water or milk. Humans are true reservoir of *S.typhi* in nature. The sources of the organism are human cases, faeces of convalescent carriers, and carriers. Organisms survive freezing, drying and spread through ice, dust, food and sewage. Maximum cases are seen where the sanitation is suboptimal. Incidences are more in summer months. There is decrease in typhoid cases where pure drinking water supplies are maintained and effective sewage disposal is in place.

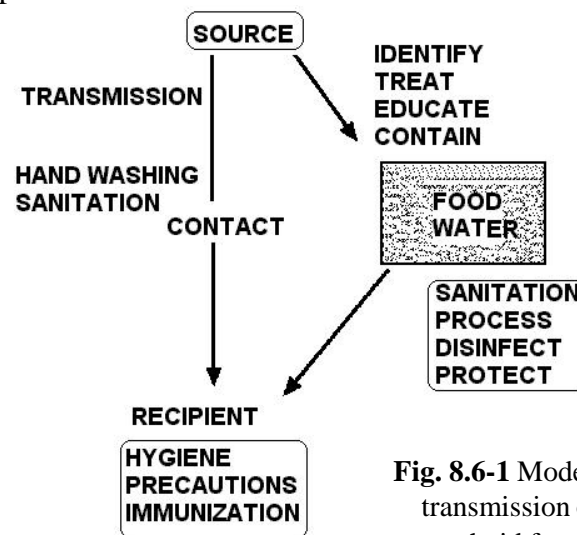


Fig. 8.6-1 Modes of transmission of typhoid fever

#### Incubation period

The incubation period of typhoid is usually from 8 to 15 days, with wide variations; up to 40 days has been recorded. Long incubation periods tend to follow infection with small doses of organisms.

## Onset

In about 10% of patients the onset is abrupt, resembling classical septicemia. Usually, the patient's illness starts with a feeling of vague malaise and restlessness which may go on for days with no clear presenting picture, which explains why the diagnosis may be missed, even by experienced clinicians in endemic areas, especially when other febrile diseases are common

## Complications of enteric fever

(1) **Relapse:** Relapse constitutes the commonest complication of typhoid, occurring in some 10-20% of cases. In this, the symptoms recur following the end of the initial, classical, attack. Without treatment, the course of a relapse is normally shorter and milder than the initial attack, but prolonged, severe and even complicated disease may occur.

(2) **Perforation:** Perforation of the bowel occurs in 0.5-5% of cases and continues to be the most dreaded complication of typhoid.

(3) **Haemorrhage:** Haemorrhage from the bowel ulcerations may occur early in the disease but as the disease progresses larger vessels may be involved and, in pre-antibiotic days, severe haemorrhage occurred in 10-20% of patients. This could be acute and catastrophic

The paratyphoid fevers generally yield milder illness than typhoid. Individual cases of enteric fever cannot be diagnosed as typhoid or paratyphoid on clinical grounds alone.

## Pathogenesis

The infectious dose is believed to pass through the stomach and pylorus. Then invasion of epithelium takes place in the small bowel. The bacteria penetrate the cells without causing cellular disruption and pass through to the lamina propria. Here the bacteria are not adequately contained and spread to mesenteric lymph nodes. By way of the lymphatic system and the thoracic duct, they reach the bloodstream, giving rise to a transient and usually symp-

tomless primary bacteraemia. They settle largely in spleen, liver and bone marrow and are constrained for the remaining incubation period. At the end of this interval, multiplication of the organisms gives rise to a secondary and persistent bacteremia along with the signs and symptoms of the disease. Bacteria then pour into the bowel from the biliary tract. The mesenteric nodes remain infected from the start but the intestinal epithelium may be cleared except at the lymphatic aggregates.

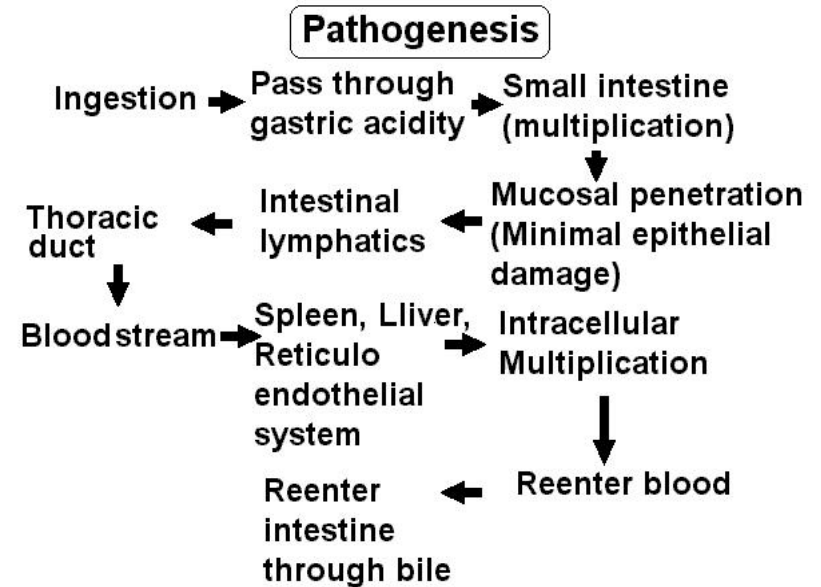


Fig. 8.6-2 Pathogenesis of typhoid fever

## Laboratory diagnosis

For the laboratory diagnosis of typhoid, attempts are made to:

(1) Isolate and identify the organism (2) to recognize a specific immunological response to the agent or (3) directly detect the etiological agent, or its specific products antigens or genomic elements - possibly after amplification.

## **Isolation of the etiological agent**

### **Selective and indicator media**

Indicator and selective media are essential to allow the isolation of enteric pathogens from contaminated sites. In most media, selection was obtained by the incorporation of certain dyes. Lactose non fermentation was the basis of indication of likely colonies. More than a single medium, Leifson's deoxycholate-citrate agar (DCA), Taylor's xylose-lysine-deoxycholate (XLD) and variants of Wilson and Blair's bismuth sulphite media are all highly effective.

### **Enrichment media**

For culture from faeces and other contaminated specimens, preliminary specific enrichment of the pathogen in a liquid medium was used which increased the yield. Müller's tetrathionate broth and selenite broths of Leifson, are generally used. More than a single broth is essential to recover a full range of serovars of *Salmonella*.

### **Selection of specimens**

*S. typhi* is maximally isolated from blood in the first week of disease, from faeces in the second and following weeks, and from urine in the third and fourth weeks.

### **Blood**

Blood culture is the most useful diagnostic procedure for the diagnosis of clinical enteric fever. It is often positive during the early ambulant phase of the disease. It continues to be positive until effective treatment is given. It is positive during relapses.

For success, 10 ml of blood is taken into a suitable 50 ml of liquid medium on several occasions. 'Clot culture' in which the serum is removed from a blood specimen and the clot is used for culture.

### **Faeces**

Culture of faeces is a standard diagnostic technique and repeated specimens over 2-3 days should be tested as there is variation in the shedding of the organisms.

### **Urine**

During enteric fever, organisms are often shed in the urine, and for diagnosis of cases or carriers 5-20 ml volumes can be mixed with equal volumes of selenite enrichment broth for incubation and subculture.

### **Bile**

Culture of a duodenal aspirate, rich in bile, has yielded *S. typhi* when other methods have failed. Both cases and carriers have been diagnosed.

### **Identification of cultures**

Presumptive identification is performed by examining the responses of a purified culture to a set of standard biochemical tests. Standard slide agglutination tests is done to confirm the identity of the organism using known antisera.

### **Serology**

Widal near the end of the nineteenth century found that the sera of typhoid patients developed agglutinating antibodies to *S. typhi*. A bacterial agglutination test named after Widal is used in the diagnosis of enteric fever (typhoid and paratyphoid fevers) which is caused by *S. typhi*, *S. paratyphi A*, *S. paratyphi B* and *S. paratyphi C*. enteric fevers due to *S. typhi* and *S. paratyphi A* and B are common in India.

Antigens prepared from these strains are used in the agglutination test to detect the presence of antibodies in patient's sera which are elicited in response to infection by these bacteria. These organisms possess two major antigens namely somatic "O" and flagellar "H" antigens. Widal test detects the amount of antibodies

formed in the patient's serum. The results of the Widal test must be interpreted carefully keeping in mind the following :

1. antibodies appear after 1 week of infection.
2. Early treatment with antibiotics will interfere with antibody production.
3. anamnestic response may lead to the presence of low level of antibodies in serum.
4. TAB vaccination leads to "H" antibody rise.
5. "O" antibody rise indicates recent infection.
6. "H" antibody is specific for the infecting organisms.
7. A titre of 1:100 and above in "O" and "H" indicates active / recent infection.
8. When low titer is observed the test is repeated to show rise in titer after a week and a four fold increase in titer indicates active infection.
9. Agglutinins to the somatic (TO) antigens develop later in the illness and decline slowly and variably in recovery, but those to flagellar antigens (TH) rise early and persist.

### **Treatment**

Chloramphenicol is effective in rapid clinical improvement and a dramatic decline in mortality. But it was noted that faecal excretion of organisms continued during treatment and that the incidence of relapses was increased. Co-trimoxazole (trimethoprim-sulpha- methoxazole) can be a useful second-line drug. The fluoroquinolones are active by mouth, penetrate well in tissues and are concentrated in phagocytes and bile and have been highly effective in treating enteric fever. Ciprofloxacin and ofloxacin have been most commonly used, and found superior to ceftriaxone. They represent the drugs of choice in the treatment of enteric fever.

### **Points to remember**

1. Incubation period for typhoid is 7-20 days and the onset is insidious.
2. Fever is gradual and then rises to the high plateau. The disease lasts several weeks with gastrointestinal symptoms.
3. Blood culture is positive in 1<sup>st</sup> and 2<sup>nd</sup> weeks of disease and stool culture is positive from second week. Antibody rise is seen after seven days.

## Chapter 8.7

### SHIGELLA

The genus *Shigella* belongs to the family Enterobacteriaceae. It contains four species *Shigella dysenteriae*, *Shigella flexneri*, *Shigella boydii* and *Shigella sonnei*. These are differentiated based on their biochemical and serological characteristics.

Shigellae are Gram negative bacilli which can not be differentiated from other enterobacteria by morphology. They are non motile, non-spore forming and non capsulated. They do not ferment lactose but *Shi. sonnei* ferments lactose slowly. The antigenic structure is complex. Based on antigenic structure *Sh.dysenteriae* can be sub-divided into 13 and *Sh. boydii* into 18 specific serotypes. Strains of *Sh. flexneri* are divided into six serotypes where as *Sh. sonnei* has two serotypes. Shigellae cause acute bacillary dysentery in man.

#### Clinical features:

Bacillary dysentery is characterized by the frequent passage of blood stained muco purulent stool. It is caused by the members of the genus *Shigella* and is prevalent in many countries. The incubation period is between 2-3 days or may be short. The initial symptom is abdominal colic. This is followed by watery diarrhoea, fever and malaise. In mild cases it resolves at this stage but others progress to abdominal cramps, tenesmus and frequent passage of small volumes of stool mainly consisting of bloody mucus. The symptoms may last for 4 days but may continue for 10 days or more. Some species may cause febrile convulsions, disseminated intravascular coagulation and acute renal failure in children.

#### Pathogenesis:

Bacillary dysentery may follow ingestion of as few as ten viable bacteria. The site of infection is the M cells in the Peyer's

patches of the large intestine. The shigellae multiply within the epithelial cells and spread laterally into adjacent cells, and ulcers are formed. The infected epithelial cells are killed and other cells develop an inflammatory reaction with capillary thrombosis. As a result, polymorphonuclear leucocytes, red blood cells and damaged epithelial cells are poured into the lumen of intestine. They are excreted in the stool along with other materials.

Shigellae rarely invade other tissues. Rare bacteraemia can occur, but septicemia is very rare.

*Sh. dysenteriae* I produces a potent protein toxin (Shiga toxin). Shiga toxin remains active within endosomes. It prevents protein synthesis and causes cell death. Hemolytic uraemic syndrome is thought to be caused by the action of shiga toxin on kidney tissues. It has also been shown to have neurotoxic properties.

#### 8.9-1 LABORATORY DIAGNOSIS:

The specimen of faeces is always preferable. The specimen is inoculated onto Desoxycholate Citrate Agar (DCA) or Mac Conkey Agar. If mucus is present that may be used as inoculum.

After overnight incubation pale non-lactose fermenting colonies are tested by standard biochemical and sugar utilization tests to differentiate from other enterobacteria. Identity is confirmed by serological tests with species-specific rabbit antibodies.

#### TREATMENT:

Most cases of *Shigella dysentery* are mild and do not require antibiotic therapy. Symptomatic treatment with oral rehydration salt solution may be required. Treatment with suitable antibiotic is necessary in very young, the aged and in severe infections. Ampicillin, Co-trimoxazole, Tetracycline or Ciprofloxacin may be used if any one drug is shown to be active in vitro.

#### SOURCES AND SPREAD:

Bacillary dysentery spreads by the fecal-oral route. If the infected person does not clean his hands properly at toilet, he spreads

the bacteria to others by touching door knobs, wash basin taps and so on. When another person handles those things, he gets them in his hands and then to his mouth. It also spreads through contaminated food and water. Mainly school age children are involved and particularly primary school children. Neglect of toilet hygiene by children at school plays an important role. Sometimes it may be seasonal. Flying insects transmit the disease by transferring shigellae from human excreta mechanically to food stuffs. Foods may also be contaminated directly by human handlers.

**CONTROL:**

Good hygienic toilet facilities, mainly in schools may reduce the spread of infection. Hand washing after the use of toilets should be taught in schools. During infection hand washing may reduce only a very little number of bacteria. So people with severe infection need to stay away from work.

**Points to remember:**

1. Shigella are Gram negative, non motile bacilli. There are four species. Bacillary dysentery is caused by the genus Shigella. In bacillary dysentery blood stained muco- purulent stool is passed.
2. *Shigella dysenteriae* I produces shiga toxin. It is a neuro toxin.
3. For treatment oral rehydration with salt solution is recommended.
4. Bacillary dysentery spreads by the fecal-oral route. So good hygienic toilet facilities mainly in schools may reduce the spread of infection.

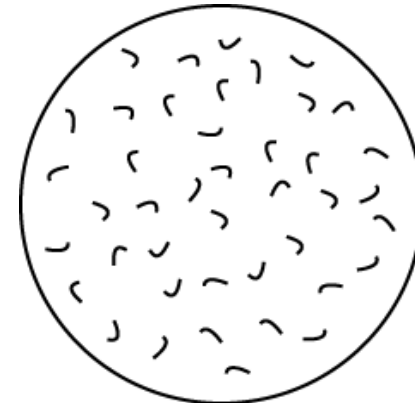


## Chapter 8.8

### VIBRIO

The genus *Vibrio* includes more than thirty species that are found commonly in aquatic environment. The most important pathogens of man are *Vibrio cholerae* and *Vibrio parahaemolyticus*.

Vibrios are short Gram negative rods which are often curved and actively motile by a single polar flagellum. They produce the enzyme oxidase and indole. The genus can be divided into non-halophilic vibrios which grow in media without added salt and halophilic vibrios which grow in ordinary media with added electrolytes. Most vibrios grow at 30°C, but halophilic species poorly grow at 37 °C, but *V. cholerae* and *V. parahaemolyticus* grow even at 42 °C.



**Fig. 8.8-1** *V.cholerae*

The somatic antigenic (O antigen) structure is the important factor in identification of the organism. More than 200 different O serogroups have been described. If the vibrio possesses O1 antigen, the organism is known as *V. cholerae* O1. Other strains are collectively known as non-O1. All strains of *V. cholerae* share the same flagellar (H antigen) antigen. Strains of *V. cholerae* O1 may be subdivided on the basis of O antigens into two subtypes Inaba and

Ogawa. There are two biotypes of *V. cholerae* O1. They are classical and El Tor biotypes. The El Tor variant is distinguished from the classical biotype by the ability to express the hemolysin and resistance to Polymyxin-B

### **CLINICAL MANIFESTATIONS:**

Effortless vomiting and profuse watery diarrhea are the characters of cholera. The rapid dehydration and hypovolaemic shock may cause death in 12-24 hrs. The watery stool is colourless with flecks of mucus and distinctive fishy odour and also called “rice water stool”.

It contains little protein and is different from the mucopurulent blood – stained stools of bacillary dysentery. Anuria and muscle cramps occur and the patient becomes weak and lethargic with low blood pressure and absent or thready pulse.

### **PATHOGENESIS:**

The Cholera vibrios are ingested in drink or food and the dose is small. After passing the acidity of the stomach, the organisms begin to multiply in the alkaline environment in the small intestine. With the help of enzymes produced by the organisms, they penetrate the mucous layer and adhere to the enterocyte surface.

### ***Vibrio Cholerae* Enterotoxin :**

The major virulence factor in *vibrio cholerae* is cholera toxin. It is a heat labile enterotoxin with a molecular weight of about 84,000, consisting of sub units A (M.W. 28,000) and B. The sub-unit-B attaches on Ganglio side GH1 which serves as the mucosal receptor, and it promotes entry of sub-unit A into the cell. The A sub-unit provides the toxigenic activity intracellularly after proteolytic cleavage into 2 peptides A<sub>1</sub> and A<sub>2</sub>. A<sub>1</sub> is the active portion of the molecule.

Activation of A<sub>1</sub> sub unit increases the levels of intracellular cAMP and results in prolonged hyper secretion of water and electrolytes. There is increased sodium-dependent chloride secretion and sodium and chloride absorption is inhibited. As a result diarrhoea occurs, with 20-30 litre/day loss of water.

### **LABORATORY DIAGNOSIS:**

Stool specimens are collected and inoculated into alkaline peptone water. Vibrios grow faster than other organisms. After incubation for 3 – 6 hours, a loopful from the surface is inoculated on TCBS [Thiosulphate Citrate Bile salt Sucrose] agar. On this medium *V. cholerae* strains appear as yellow, sucrose fermenting colonies. The colonies should be tested for the enzyme oxidase and then biochemical tests are done. Confirmation of *V. cholerae* is done with rabbit antibodies specific for O1 antigen. If agglutination occurs, it is confirmed.

### **TREATMENT:**

In cholera the main treatment is replacement of fluid and electrolytes. Oral fluid therapy is sufficient, but in severe cases intravenous rehydration is required. WHO recommends oral rehydration therapy. Tetracycline, Chloramphenicol and Co-trimoxazole reduce the period of excretion of *V. cholerae* in cholera patients. Tetracycline is also used to reduce environmental contamination.

### **EPIDEMIOLOGY, PREVENTION AND CONTROL :**

The pandemic of cholera occurred in the 1800 and early 1900s. The classic biotype was prevalent through 1960s. The ElTor biotype which was discovered in 1905 became prevalent in the late 1960s, and had caused the seventh pandemic of cholera in Asia, Middle East and Africa.

Cholera is endemic in India and South East Asia. From these centers it is carried by shipping trade routes and pilgrim routes. The disease spreads from person to person contact involving individuals. vibrios survive in water for upto 3 weeks.

Control measures depend on how people are educated on improvement of sanitation, particularly of food and water. Patients should be isolated. Even though antimicrobial drugs have a place in treatment vaccine is also recommended to heavily exposed persons but it is not effective. As an endemic control measure very few countries ask for the vaccination certificate for cholera but WHO vaccination certificate is valid for 6 months only.

## **VACCINE**

Immune response is directed against the bacterium and not against the toxin. Infection with *V. cholerae* gives complete immunity for few years. Traditional whole – cell vaccines are not very effective and are not recommended for travellers. Killed vaccines are licensed in some countries and appear to be safe and give protection for six months only. Live attenuated oral vaccines are on trial.

### **Points to remember**

1. Vibrios are short Gram negative curved rods, which are oxidase positive. There are many serotypes and among them *V. cholerae* O1 and O139 produce epidemic cholera,
2. The organisms are ingested in contaminated water and food. Effortless vomiting and profuse watery diarrhea are the characteristics of cholera.
3. Cholera toxin is responsible for the diarrhoea.

## Chapter - 8.9

### CLOSTRIDIUM TETANI

Anaerobic bacteria are found through out the human body, on the skin, on mucosal surfaces and in high concentrations in the mouth, and gastrointestinal tracts as part of normal flora. They do not grow in presence of oxygen and are killed by oxygen. Infections are produced when anaerobes of the normal flora contaminate normally sterile sites of the body. Several important diseases are caused by anaerobic clostridium species from the environment or from the normal flora. They are botulism, tetanus, gas gangrene, food poisoning and pseudomembranous colitis. *Clostridium tetani* organisms are straight, slender Gram positive bacilli with rounded ends. The fully developed spore gives the bacilli drumstick appearance.

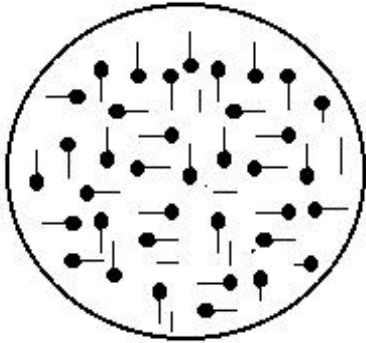
The tetanus bacillus is an obligate anaerobe which is motile with numerous peritrichous flagella. It grows well in cooked meat broth and produces a thin film when grown on enriched blood agar. The spores may be highly resistant to adverse conditions like boiling water, dry heat at 160°C and 5% phenol. 1% iodine in water kills the spores in few hours.

Tetanus bacilli may be found in the human intestine, but people get the infection from animal faeces and soil. The organism is present in the manured soil. Tetanus spores occur very widely and are present in gardens, sports fields and roads, in the dust, plaster and air of hospitals and houses, on clothing and on articles of common use. For this reason a wound through skin contaminated with soil or manure deserves a special attention.

#### TOXINS

Two types of toxins are produced by *C. tetani*. One is oxygen labile haemolysin and is called tetanolysin. The other one is the essential pathogenic product, a neurotoxin and is called tetanospasmin.

The estimated lethal dose for a mouse of pure tetanospasmin is 0.0001  $\mu\text{g}$ . It is toxic to man and various animals when injected parenterally, but not by oral route.



**Fig. 8.9-1** Clostridium tetani

When the disease occurs naturally the tetanus bacilli stay at the site of infection and are not invasive. But the toxin diffuses to affect the spinal cord and then the entire system. The toxin is absorbed and delivered to all nerves by blood.

The toxin reaches the central nervous system by passing along the motor nerves. Toxin first passes to part of the brain stem or spinal cord and causes local tetanus. Then by local spread, up the spinal cord, produces ascending tetanus. After reaching the brain stem, spreads downwards causing lockjaw followed by descending tetanus. Tetanus toxin causes over action of motor cells in the anterior horn of the spinal cord, and then diffuses into the whole central nervous system. The toxin affects the membrane of synaptic vesicles. This prevents the release of neurotransmitter  $\gamma$ -aminobutyric acid.

More neurons are left under no inhibitory control and undergo sustained excitatory discharge causing the characteristic motor spasms of tetanus. The toxin exerts its effects on the spinal cord, the brain stem, peripheral nerves, at neuromuscular junctions and directly on muscles.

## **PATHOGENESIS**

Tetanus occurs usually as the result of contaminated wound with *C. tetani* spores. If washed spores are injected into an animal they fail to germinate and are removed by phagocytosis. Germination of the spores depends on reduced oxygen tension occurring in devitalized tissues and non-viable material in the wound. Infection is localized, tetanic condition occurs due to the toxin. Tetanus toxin does not cause death of the adjacent tissues and does not bring about the spread from its initial focus. Cases of tetanus have been reported from superficial abrasion or a minor thorn prick. Gardening enthusiasts form one of the recognized risk groups. Otogenic tetanus (infection of the external auditory meatus), cryptogenic tetanus (site of infection undiscovered), uterus tetanus, tetanus neonatorum (infection of the umbilical wound of new born infants) and post operative tetanus have been reported.

## **CLINICAL FEATURES OF TETANUS**

Symptoms start with some stiffness and pain in or near the recent wound. In some cases the initial complaint may be of stiffness of the jaw (Lock jaw). Pain and stiffness in the neck and back may follow. The stiffness spreads to involve all muscle groups. Facial spasms produce the “sporadic grin” and in some cases spasm of the back muscles produces the opisthotonos (extreme arching of the back). It takes 10-14 days between the injury and the first sign and also it may vary. Sweating, tachycardia, arrhythmia and swings in blood pressure may also be seen.

## **LABORATORY DIAGNOSIS**

Specimens from wounds are collected and Gram stained. The smear shows characteristic Gram positive drum stick shaped bacilli. They may confuse with other bacilli with terminal spores. Simple microscopy may not be useful, immuno fluorescence microscopy with a special stain may be effective but not generally available. Direct culture of the unheated material on blood agar should be incubated anaerobically. Specimen from wound should be heated at varying temperatures for various spore forming organisms. Tetanus may be produced in mice by sub-cutaneous infection

of the anaerobically grown culture. Control mice are protected with tetanus antitoxin.

### **TRATMENT**

The patient is conscious and requires sedation and constant nursing. Intravenous injection of large initial dose of antitoxin (30,000 to 200,000 units) followed by intramuscular injection, are recommended immediately. The wound is cleaned and left open with a loose pack. Surgical removal of necrotic tissue is essential.

The patient is given 10,000 units of human tetanus immunoglobulin (HTIG) in saline by slow intravenous infusion. Penicillin or metronidazole is given for as long as considered necessary. Previously immunized individual when wounded should be given booster dose of tetanus toxoid to stimulate the antitoxin production.

### **EPIDEMIOLOGY:**

Tetanus comes under the major lethal infections. There are around 1 million deaths annually from tetanus of which 400,000 are due to neonatal tetanus. Thus the disease varies from country to country, and is universally proportional to socio-economic development and standard of living, preventive medicine and management of wound. Treatment of the umbilical cord with cow dung, tying of umbilical cord with primitive ligatures and ear piercing with unsterile instruments may cause tetanus.

### **PREVENTION AND CONTROL:**

Wound management is of the first and foremost importance. Otherwise tetanus spores will germinate in the unclean wounds. Active immunization: Universal active immunization with tetanus toxoid is mandatory. All persons should be actively immunized against tetanus in infancy and their immunity is maintained by booster doses of toxoid at intervals of five to ten years. Tetanus toxoid is a preparation of refined toxin that has been rendered non-toxic by treatment with formaldehyde (formal toxoid). A soluble toxoid is made more effective by adsorption on to an aluminium hydroxide carrier (adsorbed toxoid). Tetanus

toxoid is given along with Diphtheria and pertussis as a triple vaccine in childhood.

A course of three 0.5 ml doses of tetanus toxoid with intervals of 6-12 weeks between the first two, and 6-12 months between the second and third injections. A booster dose of 0.5 ml may be given at intervals of five to ten years to maintain immunity. A careful record should be kept of all prophylactic injections.

### **PASSIVE IMMUNIZATION:**

Tetanus antitoxin is often called antitetanus serum or ATS can be obtained by immunizing horses with toxoid. This serum is of value in the prophylaxis of tetanus if given immediately after wounding. Its use as a curative agent after development of tetanus is less effective.

### **COMBINED ACTIVE AND PASSIVE IMMUNIZATION:**

Patients receiving passive protection with antitoxin after injury, should also be given tetanus toxoid. An injured non-immune patient may receive from separate syringes, 1500 units of equine tetanus antitoxin or 250 units of homologous ATG intra muscularly in one arm and 0.5 ml of the adsorbed toxoid in the other. The patient is advised to have a second injection of 0.5 ml of adsorbed toxoid 6-12 weeks later.

### **Points to remember:**

1. *Clostridium tetani* is an anaerobic bacterium. It forms round terminal spore which gives drum stick appearance to the bacilli.
2. It produces two toxins, one is a potent neurotoxin called tetanospasmin which acts on neuromuscular junction and causes lock jaw and characteristic spasm of tetanus. The other is a hemolysin.
3. Tetanus toxoid is given along with diphtheria and pertussis as a triple vaccine in childhood.

## Chapter - 8.10

### CLOSTRIDIUM BOTULINUM

*Clostridium botulinum* is an anaerobic Gram positive motile bacillus with peritrichous flagella. It is a saprophyte widely seen in soil, vegetable, fruits, leaves, manure and mud of sea and lake. It produces a potent neurotoxin in food. It produces spores which are oval in shape and sub terminal. They resist boiling and heating and are usually destroyed by moist heat at 120 deg C within 5 minutes. Insufficient heating in the process of preserving food may cause the multiplication of the organism.

#### Toxins of *C. botulinum*

Botulinal toxins are among the most poisonous natural substances known. There are 7 main types of *C. botulinum* and they are known as A to G. All of them produce antigenically distinct toxins but their actions are identical and they all cause human diseases, but A, B and E are most common. If antitoxin is given to a patient in an emergency, type specific antitoxin will be effective. Type E strains are associated with marine products but Type A and B are associated with soil.

#### Clinical Features

The period between the ingestion of toxins and appearance of signs and symptoms is 1 – 2 days but it may be longer also. Initially there is nausea and vomiting. The oculomotor muscles are affected and there may be vertigo and blurred vision. There is progressive descending motor loss with flaccid paralysis but with no loss of consciousness or sensation. The patient is thirsty with a dry mouth and tongue, there are difficulties in speech and swallowing with later problems of breathing and despair. There may be abdominal pain and restlessness. Death is due to respiratory and cardiac failure.

#### Botulism

Botulism is a severe, fatal form of food poisoning with characteristic neurotoxic effects. The disease has been caused by a wide range of foods usually preserved food, home preserved meat, vegetables, canned products such as fish, liver paste and even honey.

Foods responsible for botulism may not show signs of spoilage. The preformed toxin in the food is absorbed from the intestinal tract. It is a protein and is not inactivated by the intestinal proteolytic enzymes. The toxin is made up of two parts. A is the small part and B is the larger one. The larger part binds to the motor nerve end plates. The smaller part blocks the calcium mediated release of acetyl choline.

#### Wound Botulism

Rare cases of wound infections with *C. botulinum* have been reported.

#### Infant Botulism

Young children usually less than 6 months are affected by *C. botulinum* and the organisms colonize the intestine as the resistance is poor. There are various grades of syndrome. They develop poor feeding, weakness and signs of paralysis. This is one of the reasons of sudden death syndrome. Organisms and toxin are found in the faeces and not in the blood. The reason may be the presence of spores in the honey which is used for feeding. The spores germinate and produce toxins in the infant gut.

#### Laboratory Diagnosis

The suspected food samples, faeces or vomit may be taken as specimens. The organism or its toxin may be detected in the suspected food. Toxin may be demonstrated in the patient's blood by toxin – antitoxin neutralization test in mice. Botulinal toxin is very dangerous and care should be taken while handling the specimen and toxin.

Gram stained smears of the food may be examined for the sporing bacilli. The samples should be heated at 65 – 80 °C for various times to eliminate non – sporing bacteria and cultivated anaerobically.

*C. botulinum* is grown from the food remains. Inoculated blood agar plates are placed in air tight container from which air is removed and replaced by nitrogen with 10% CO<sub>2</sub>. Fluid media such as cooked meat medium and thioglycolate medium can also be used. *C. botulinum* is identified based upon its biological characteristics and toxigenicity. In addition, immunofluorescence staining may be used if conjugated antisera are available.

### **Treatment**

Antitoxin is prepared by immunizing animals with toxoid preparations and it is used therapeutically. In general a bivalent serum containing antitoxins to A and B types of toxin has been used for prophylaxis and treatment. Antitoxin to type E is also added as a routine. Intensive care should be given to patients.

### **Control**

The spores are present in soil and contaminate vegetables and fruits. Chief problem lies in home canned food like peas and pickles. Home canning of food stuffs should be avoided and commercial canning must be strictly controlled. Preservation of vegetables and other eatables by inexperienced hand is dangerous. Fruits may be bottled by heating at 100 °C because the organism does not grow in acid pH.

A prophylactic dose of polyvalent antitoxin should be given intramuscularly to all persons who have eaten food suspected of having caused botulinum. Active immunity can be obtained by injecting 3 doses of mixed toxoid at intervals of 2 months but the incidence is too low and it is not needed as a routine. But laboratory staff who handles the organisms or specimen containing organisms or toxin should be given active immunization.

### **Points to remember**

1. *Clostridium botulinum* toxins are among the most poisonous natural substances known. *Clostridium botulinum* causes botulism, a severe, fatal form of food poisoning with characteristics neurotoxic effects.

2. The toxin blocks the release of acetyl choline and causes flaccid paralysis. It also causes infant botulism.
3. If the botulinum spores are present in the canned or preserved food, they germinate in the intestine and toxins are produced. Home canning of food stuffs should be avoided. Preservation of eatables by inexperienced hand is dangerous.



## Chapter - 8.11

### CHLAMYDIA

#### Introduction

Chlamydiae are large group of obligate intracellular parasites. They closely resemble Gram negative bacteria. They are among the most common pathogens throughout the animal kingdom. There are four species: 1. *Chlamydia trachomatis* 2. *Chlamydia psittaci* 3. *Chlamydia pneumoniae* 4. *Chlamydia pecorum*.

#### Common characteristics of Chlamydia

They are non motile, Gram negative, obligate intracellular bacteria. Particle size varies from 250-500 nm. Multiplication is by means of an unique developmental cycle (different from other microorganisms). They replicate within the cytoplasm of the host cell and produce characteristic inclusion bodies.

Inclusion bodies can be seen by light microscopy. They differ from the viruses by possessing both RNA and DNA. Cell wall structure is similar to Gram negative bacteria. They are susceptible to antimicrobial agents such as sulfonamides, chloramphenicol, tetracycline and also possess number of enzymes with limited metabolic capacity. These metabolic reactions do not yield energy to the cell, so they are considered energy parasites. They use energy produced by the host for their own requirements. Chlamydiae possess group specific, complement fixing antigens. The individual members are identified by their virulence to different hosts, pathology produced and possession of specific antigen.

#### Taxonomy

Order: Chlamydiales

Family: Chlamydiaceae

Genus: Chlamydia

Species:

1. *Chlamydia trachomatis*.
2. *Chlamydia psittaci*.
3. *Chlamydia pneumoniae*.
4. *Chlamydia pecorum*.

#### 1. Chlamydia trachomatis

It includes organisms causing: i. Trachoma, ii. Inclusion conjunctivitis, iii. Lymphogranuloma venereum (LGV), iv. Genital tract diseases. These are sensitive to sulfonamides.

#### 2. Chlamydia psittaci

These strains infect many avian species, and mammals. They cause diseases such as: Psittacosis, Ornithosis, Feline pneumonitis, Bovine abortion. These are resistant to sulfonamides

#### 3. Chlamydia pneumoniae

Exclusive human pathogen.

#### 4. Chlamydia pecorum

Pathogenic role not established .

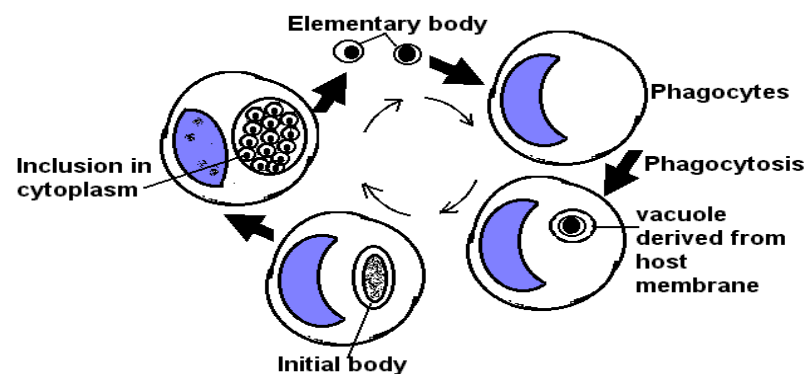


Fig.8.11-1 Multiplication of Chlamydia

All Chlamydia share a general sequence of events in their reproduction.

The infectious particle is a small cell. It is called elementary body, 0.3  $\mu\text{m}$  in size. It contains electron dense nucleoid. It is taken into the host cell by phagocytosis. A vacuole derived from host cell membrane forms around small particle.

The small particle is reorganized into a large one. It is called Initial body, 0.5  $\mu\text{m}$  in size. It is devoid of electron dense nucleoid

Large particle grows in size within the vacuole. It divides repeatedly by binary fission and the vacuole is filled with small particles called inclusion

### Differences between elementary and reticulate body

Elementary body	Reticulate body(Initial body)
Size about 0.3 $\mu\text{m}$	0.5 $\mu\text{m}$
Rigid cell wall	Fragile cell wall
Relatively resistant to sonication	Sensitive to sonication
Resistant to trypsin	Lysed by trypsin
Subunit in cell envelope	No sub unit in envelope
RNA:DNA content is 1:1	RNA:DNA is 3:1
Toxic for mice	Not toxic for mice
Infectious	Not infectious
Adapted for extracellular survival	Adapted for intracellular growth

### Structure and chemical composition

Examination of highly purified materials reveal:

#### Outer cell wall

It resembles the cell wall of Gram negative bacteria, contains relatively high lipid content.

It is rigid and does not contain typical bacterial peptidoglycan. The tetra peptide linked matrix is seen. Penicillin binding proteins occur in chlamydiae. Cell wall formation is inhibited by penicillins and cycloserine and substances that inhibit transpeptidation. Lysozyme has no effect on chlamydial cell wall and N-acetyl muramic acid appears to be absent

### Nucleic acids

Both DNA and RNA are present in initial and elementary bodies.

**DNA:** DNA is concentrated in electron dense nucleoid in elementary body. DNA is distributed throughout the cytoplasm in initial body.

**RNA:** Most RNA exists in ribosomes in cytoplasm. Large initial body contains 4 times as much RNA as DNA. Small elementary body contains equal amounts of RNA and DNA. Chlamydiae possess circular DNA as that of bacterial chromosome. Chlamydia contains large amount of lipids. They are phospholipids in nature.

### Toxic moiety

Toxicity is associated with infectious chlamydiae. It kills mice after i.v injection of  $>10^8$  particles. Toxicity is destroyed by heat but not by UV light.

### Inclusions of Chlamydia

Fully formed intracellular inclusions are seen in cytoplasm.

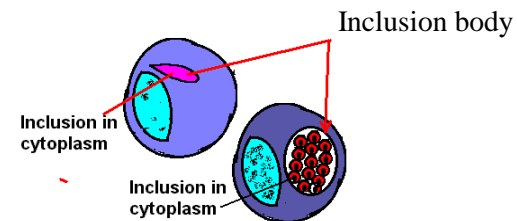


Fig. 8.11-2 Inclusion body

They are seen as compact mass near the nucleus. They appear dark purple when stained with Giemsa and Red with

Macchiavello stains. When stained with Lugol's Iodine they appear as brown inclusions.

In Trachoma, Inclusion conjunctivitis and LGV the inclusion body consists of a colony of small (elementary and Large (reticulate) particles of varying proportions.

### **Trachoma**

Trachoma is a specific kerato conjunctivitis caused by *Chl. trachomatis*, severe complicated cases may lead to partial or total loss of vision. Severe cases occur in endemic areas.

### **Etiology**

It is caused by *Chl. trachomatis* sero group A, B1, B2, and C.

### **Epidemiology of Trachoma**

It occurs throughout the world . There is no relation to climate or race. It is a serious public health problem in Africa, Asia, and Latin America. Spread is from eye to eye through direct or indirect contact with infected material. Extraocular location occurs and is mainly genital. Venereal transmission does occur. When the agent localizes in cervix uteri infection of the newborn occurs similar to inclusion conjunctivitis.

In endemic areas, severity of the disease is influenced by duration of illness, occurrence of relapse or reinfection. Association with Haemophilus and Moraxella complicates disease. In endemic areas complication may be seen in young children. Spread of infection is facilitated by use of common towels, eye cosmetics, contaminated water for washings, Presence of flies.

### **Pathogenesis and Pathology of Trachoma**

On the palpebral conjunctiva, the process begins with diffuse hyperemia, infiltration leading to vascular papillae and lymphoid follicles. Both upper and lower lids may be involved. Typically upper tarsal plate is involved, later cicatricial tissues develop

due to follicular necrosis. Diffuse infiltration or fibrosis also seen. Structural alteration in the lids develop due to retraction of cicatricial tissue.

This leads to trichiasis and enteropion leading to partial or total loss of vision. In cornea, infiltration and neovascularization of upper limbus occur which may extend downwards and reach pupillary area. Corneal conjunctiva may be affected. Follicles may develop at the upper limbus. Superficial keratitis may occur. Reabsorption of infiltration at the limbus may lead to formation of Herbert's pits and Corneal opacity may lead to ulceration. Follicles have been described on urethral and cervical mucous membranes in extraocular cases.

### **Diagnosis**

In endemic areas the following signs are looked for: Upper tarsal follicles, Limbal follicles or Herbert's pits, Corneal infiltration and neovascularization. Conjunctival scars of characteristic configuration.

### **Laboratory diagnosis of Trachoma**

**Specimens:** Conjunctival or corneal scrapings are collected.

**Direct demonstration:** Organisms or inclusion bodies are demonstrated using any of the following staining procedures: Giemsa stain, Gimenez stain, Macchiavello's stain, Iodine stain or by Immunofluorescence

**Isolation of agents :** Growth of the organisms is attempted in Egg yolk and Tissue cultures in which inclusions are looked for by staining or by IF. Type specific antibodies in serum and tears are demonstrated.

### **Treatment**

Tetracycline, doxycycline, erythromycin, azithromycin or ofloxacin, rifampin, clindamycin are the drugs of choice.

**Laboratory diagnosis of other chlamydial infections:** Collection of Specimen: Depends on Clinical manifestation.

### **Clinical manifestations:**

1. *Inclusion conjunctivitis:* The specimens examined are

conjunctival swab/scrapings, corneal scrapings, and purulent material from the eye.

2. LGV (L1, L2, L3)
3. *Chlamydial genital infections* : Specimens such as Urethral swab, cervical swab/endometrial/ salpingeal purulent materials, pus from bubo, rectal swab and nasopharyngeal swab are collected and examined.
4. Chlamydia pneumonia and
5. *Psittacosis* : Sputum and respiratory materials are collected and examined.

**Transport to the laboratory** : Materials are collected in transport medium such as Sucrose phosphate with bovine serum or Sucrose phosphate gluconate with bovine serum. They are transported immediately or refrigerated at -40°C or -60°C.

Diagnostic procedures: such as 1.Cytology, 2.Culture and 3. Antigen detection are undertaken.

**Points to remember:**

1. Chlamydiae are intracellular microorganisms that resemble Gram negative bacteria.
2. They cause variety of human infections such as ocular infections, genital infections and respiratory infections.
3. They have specialized sequence of events in their reproduction and produce inclusion bodies inside the cells.
4. Chlamydiae possess group and species specific antigens.
5. Trachoma is caused by serogroup A, B and C, urethral infections by B, D, E to K, and lymphogranuloma venereum by L1, L2 and L3.
6. Trachoma is a specific keratoconjunctivitis. Severe infections lead to loss of vision which occurs world wide.

## Chapter - 8.12

# MYCOPLASMA

### Introduction

Nocard and Roux discovered mycoplasma 100 years back. These organisms passed through bacteria stopping filter. They caused pleuropneumonia in cattle and were also called “Pleuropneumonia like organisms” (PPLO). They were also called Eton’s agents. They are pathogens of respiratory and urogenital tracts. In humans, *Mycoplasma pneumoniae* causes pneumonia. *Ureaplasma urealyticum* has been associated with non gonococcal urethritis in men. *M. hominis* caused post partum fever in women and also in uterine tube infections.

### General Characteristics of Mycoplasma

The smallest size is 125 – 250nm. They are highly pleomorphic, lack rigid cell wall, bound by a triple layered unit membrane that contains sterol. They are completely resistant to penicillins because they lack cell wall. But they are inhibited by tetracycline or erythromycin. They grow in cell free media. The centre of the colony is embedded beneath the surface giving a fried egg appearance. Growth is inhibited by specific antibody. They have an affinity for mammalian cell membrane.

### Morphology

Because of lack of cell wall, morphology is not specific. Growth in fluid media gives rise to many different forms like rings, bacillary and spiral bodies, filaments and granules. Growth on solid medium shows plastic protoplasmic masses of indefinite shape and are easily distorted.

### Culture

Mycoplasma grows in heart infusion peptone broth with 2%

agar, pH 7.8 to which 30% human ascitic fluid or animal serum is added. Incubation at 37°C for 48 – 96 hrs reveals no turbidity in fluid but centrifuged sediments show pleomorphism in Giemsa stain.

### **Growth Characteristics**

Extremely small in size. They grow on complex but cell free media. They pass through filters and are comparable with Chlamydiae or large viruses. Many Mycoplasmas use glucose as a source of energy and Ureaplasmas require urea [10%]. They grow on cell free media that contain lipoprotein and sterol.

### **Classification**

They belong to the class Mollicutes (soft skin). They lack cell wall and cell wall precursors. Mollicutes are divided into 2 orders (1) Mycoplasmatales and (2) Acholeplasmatales. Mycoplasmatales are divided into two families (1) Mycoplasmataceae and (2) Spiroplasmataceae. Mycoplasmataceae has two genera (1) Mycoplasma and (2) Ureaplasma.

### **8.14-1 Diseases caused by Mycoplasmas**

In Humans some are normal inhabitants of genitourinary tract, particularly females. In pregnant women it is associated with chorio amnionitis, post partum fever and low birth weight of infants. *U. urealyticum* requires 10% urea for growth. It causes non gonococcal urethritis and may cause male infertility. *M. pneumonia* causes pneumonia.

In Animals mycoplasma causes pleuro – pneumonia which is a contagious disease of the cattle, with occasional deaths.

### **Human infections**

There are over 150 species in the class of cell wall free bacteria known as Mollicutes. At least 15 of these species are thought to be of human origin. In humans 4 species are of primary importance. *Mycoplasma pneumoniae* causes pneumonia and joint infections. *Mycoplasma hominis* produces post partum fever, and

uterine tube infections. *Ureaplasma urealyticum* is associated with non gonococcal urethritis, lung diseases and in premature infant of low birth weight. *Mycoplasma genitalium* is related to *M. pneumoniae*, and causes pneumonia and also urethral and other infections.

### **Mycoplasma pneumoniae**

The morphology appears different according to methods of examination. Growth in fluid media gives rise to many different forms including rings, bacillary, spiral bodies, filaments and granules. Growth on solid media consists of plastic protoplasmic masses of indefinite shape that are easily distorted. *M. pneumoniae* causes atypical pneumonias.

### **Pathogenesis**

From the respiratory secretions through inhalation organisms enter the respiratory tract. They attach to the receptor on the respiratory epithelial cells, multiply and cause the disease.

### **Clinical Findings:**

Pneumonia caused by mycoplasma is generally a mild disease. It starts from asymptomatic infection to serious pneumonitis, with occasional neurologic and hematologic involvement. After the onset symptoms of fever, headache, sore throat and cough follows. The cough is non productive, later blood streaked sputum and chest pain may be seen. It may progress to very severe illness. Death is very rare but may cause cardiac failure.

### **Lab Diagnosis:**

Sputum, blood, throat swab, inflammatory exudates and respiratory secretion are collected. Direct microscopic examination is of no use. Specimens are inoculated in media to grow the organisms. Mycoplasma grows in heart infusion peptone broth with 2% agar, pH 7.8 to which 30% human ascitic fluid or animal serum has been added. Following incubation at 37 °C for 48 to

96 hrs there may be no turbidity but Giemsa stains of the centrifuged sediment shows the characteristic pleomorphic structure and subculture on solid media yields minute colonies. The colonies are round with a granular surface and a dark centre, typically buried in the agar. They can be sub cultured by cutting a small bit of agar with the colony.

### **Serology**

Rise in the antibody can be demonstrated by Complement Fixation Test, Immunofluorescence test, Passive Haemagglutination test, Cold agglutination test with human O RBC [Non – specific test]. A titre of 1 : 64 or more supports the diagnosis.

### **Treatment**

Tetracycline and erythromycin are used for treatment.

### **Prevention & Control**

Close contact with infected individuals must be avoided. No vaccine is available for clinical use.

## **MYCOPLASMA HOMINIS**

This can be associated with a variety of diseases but demonstrated only in a few cases. It is isolated from upper urinary tract infection in about 10% of patients with pyelonephritis. It is associated with infection of uterine tubes, salpingitis. It is also isolated from women with post – abortal or post – partum fever and from joint fluids of arthritis patients.

## **MYCOPLASMA GENITALIUM**

This organism is isolated from non gonococcal urethritis. Culture of *M. genitalium* is difficult. PCR, molecular probes and serologic tests are used for diagnosis. Data suggests that *M. genitalium* is associated with non Gonococcal acute and chronic urethritis.

## **UREAPLASMA UREALYTICUM**

This has been associated with many diseases but it is demonstrated only in few cases. It requires 10% urea for growth. It causes non gonococcal urethritis in few men but majority of NGU is caused by *Chlamydia trachomatis* [50%]. *U. urealyticum* is common in the female genital tract. *U. urealyticum* has been associated with lung disease in premature low birth weight infants. They acquire the organism during birth. It is associated with infertility also.

### **Points to remember**

1. Mycoplasmas are cell wall less bacteria.
2. They cause variety of infections in man, animals and plants.
3. In man it causes respiratory, and urogenital infections most commonly and other types rarely.
4. They can be cultured in artificial culture medium and sensitive to tetracycline and erythromycin.

## SECTION - IV

# MEDICAL PARASITOLOGY, MYCOLOGY, VIROLOGY AND ZOOONOSIS

## Chapter - 8.13

### LEISHMANIA (Leishmaniasis)

Leishmania species are protozoan parasites belonging to the family Trypanosomatidae and the class Mastigophora. There are many species of Leishmania that cause infections in man. Among them *L. donovani* causes Visceral Leishmaniasis or Kala Azar.

#### Characteristics of class Mastigophora

Parasites of this class possess one or more flagella which have the power of motility. They exist in flagellated phase to use them when the habitat is fluid medium as in blood or in intestine. Flagellum is used for motility and procurement of food. Change of habitat results in alteration in mode of life. Morphological variation is seen as flagellated forms in blood and non flagellated forms in tissues. Flagellated parasitic protozoa can be divided into 2 groups. The one which infects vascular system and other tissues are called haemoflagellates and the others which infect intestine of man are called intestinal flagellates.

#### Haemoflagellates

They belong to the family Trypanosomatidae and pass through a cycle in the gut of insects. Insects serve as intermediary host or vectors. Originally they were parasites of gut of insects, later adopted to be parasites of man.

#### General morphological structure

They possess complex morphological structures. Flagella for locomotion, and nucleus for special functions.

#### NUCLEUS

It is a large round oval body situated in the center of the body and known as trophonucleus which is concerned with nutritive function. It stains red in Leishman stain.

#### KINETOPLAST

This is equivalent to the nucleus of other cells. It is round or rod shaped, has two portions. The posterior portion is called parabasal body and anterior portion is blepharoplast.

#### FLAGELLUM

Flagellum is a hair like structure originating from blepharoplast. The portion from blepharoplast to surface of the body is called axoneme. Axoneme projects from anterior end as free flagellum.

#### UNDULATING MEMBRANE

It is formed by the flagellum while curving around the body and is thrown into many folds.

According to the arrangement of these structures there are five different morphological types.

#### 1. LEISHMANIAL FORM OR AMASTIGOTE FORMS

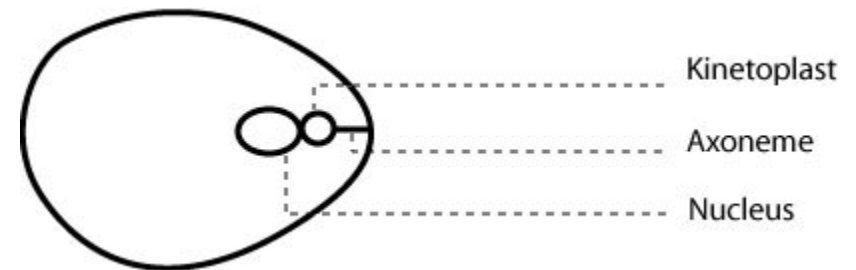


Fig. 8.13-1 Amastigote

Body is round or oval, has nucleus and kinetoplast. Axoneme is present and there is no flagellum. It measures 2-3  $\mu$ m.



## 2. LEPTOMONAD FORM OR PROMASTIGOTE FORM

The body is elongated, has central nucleus and anterior kinetoplast and free flagellum.



Fig. 8.13-2

## 3. CRITHEDIAL FORM OR EPIMASTIGOTE FORM

It has elongated body, central nucleus and kinetoplast in front of nucleus. Undulating membrane and free flagellum is present.



Fig. 8.13-3

## 4. TRYPANOSOMAL FORM OR TRYPOMASTIGOTE OR OPISTHOMASTIGOTE

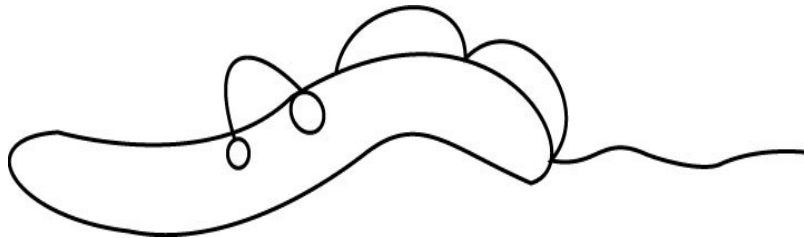


Fig. 8.13-4

This has elongated body, Central nucleus, and posterior kinetoplast. Undulating membrane is present along with free flagellum.

## 5. METACYCLIC TRYPANOSOMES

It is slender trypomastigotes

On the basis of life cycle family Trypanosomidae is divided into many genera: Important ones are: Genus *Leishmania* and Genus *Trypanosoma*.

## GENUS LEISHMANIA

This genus is named after sir William Leishman by Ross in 1903. It exists in blood and tissues of vertebrates as amastigote form. In culture and in insects as promastigote form. They have both vertebrate and insect as hosts. The species parasitic to man are *Leishmania donovani*, *Leishmania tropica* and *Leishmania brasiliensis*.

### LEISHMANIA DONOVANI

The parasite is named after the discoverers; both reported the organisms at the same time.

#### History

In India Kala azar was reported before the discovery of the organisms. In Assam, several epidemics occurred. It was confused with ancylostomiasis and severe form of malaria. Leishman in May 1903 reported the finding of the parasite in a soldier died of fever contracted in Dum Dum Calcutta - called Dum Dum fever. Donovan in July 1903 reported the organism in a patient from Madras.

#### GEOGRAPHICAL DISTRIBUTION

It is endemic in many countries like India, China, Africa, Southern Europe etc. In India it is more common in Assam, Bengal and along the coasts of Ganges and Brahmaputra.

#### HABITAT

Inside vertebrate host it is present as amastigote forms. It infects Reticulo endothelial system, monocytes, polymorphs and endothelial cells. In sand fly and culture it is present as promastigote form.

#### CULTURE

It was first cultivated by Rogers in 1904 at 22 °C. Now the medium used is NNN medium. Novy, MacNeal, Nicolle medium.

## MORPHOLOGY:

### Ultra structure of Promastigote

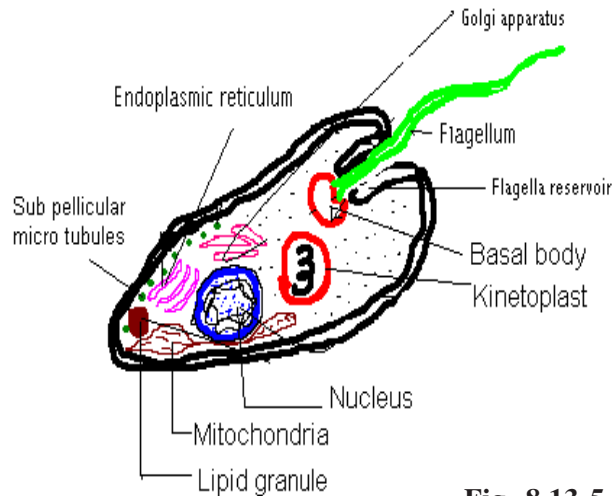


Fig. 8.13-5

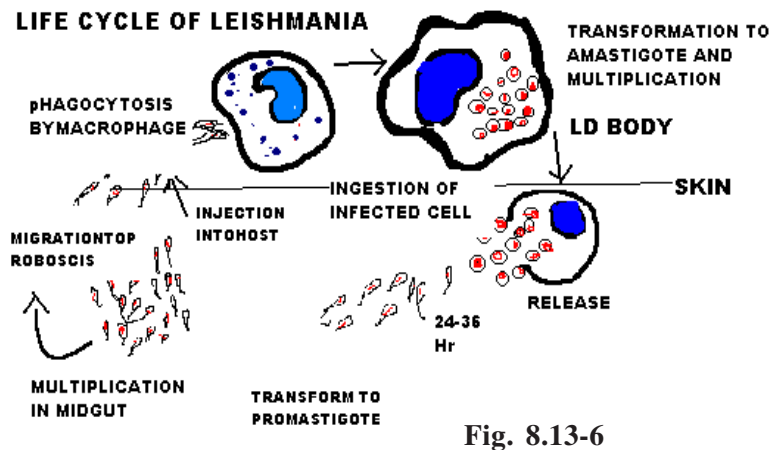


Fig. 8.13-6

*L. donovani* multiplies inside reticulo endothelial system. It divides by binary fission and the cells are packed with 50-200 amastigotes - called Leishman-Donovan (LD) bodies. They are liberated by the lysis of the cells and the parasites invade fresh cells. Blood

sucking insects take free leishmania and phagocytosed ones. In sand flies amastigotes transform into promastigotes. They multiply by binary fission in the mid gut and spread forward and reach buccal cavity in 6-9 days. This is called Anterior station development. These are introduced into the new host by the bite of *P. argentipus*.

## Pathogenicity and clinical manifestations

*L. donovani* produces a disease known as Leishmaniasis. Incubation period varies from 3-6 months. The following clinical manifestations may be seen.

### A. Inapparent infection

Infection is present but the disease is absent. Skin test is positive and antibody is present. Hepatic granuloma without disease may also be seen.

### B. Kala azar

In some cases there is acute onset of fever 104°F, rarely two peaks in 24 hr seen. In more chronic cases no fever may be present. Characteristically marked fever with little constitutional symptoms are seen so that patient's axillary lymph nodes are moderately enlarged usually the inguinal and femoral nodes (Africa). Spleen gradually enlarges and fills right iliac fossa: first soft and then hard. Jaundice is seen in 10% of cases and IgG may rise to 4 g %. Reduction in platelets and half life of RBC and RES destruction are seen.

### C. Unusual form of visceral leishmaniasis

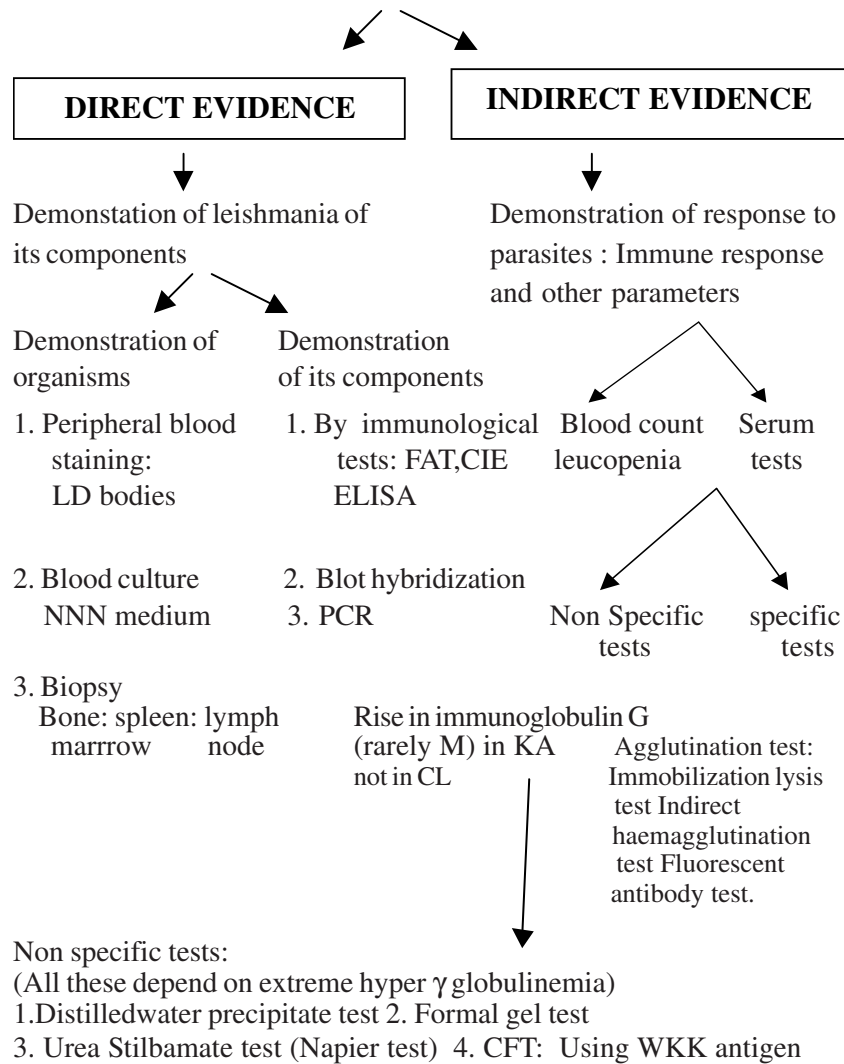
Tonsillar lesion with cervical lymph node enlargement with severe toxic form may be seen in some cases. There is rapid multiplication of organisms with necrosis and death in 4-6 weeks.

### D. Cutaneous leishmaniasis

Two kinds of clinical diseases are seen. (1) The first one is caused by: *L. tropica* major. Single or multiple skin lesions are seen with short incubation period. Considerable tissue reaction is seen with

little parasite in the tissue. Healing occurs within one year. (2) The second is caused by *L. tropica* minor. It causes single lesion. The incubation period is longer and slower growth of parasite is seen. Less tissue damage is present and healing takes more than one year.

### LABORATORY DIAGNOSIS OF LEISHMANIASIS



### Treatment

Response to therapy depends on the species of Leishmania and type of disease. Sodium stibogluconate, a pentavalent preparation of antimony is used.

### Prevention

Possible prevention methods include spraying dwellings with residual insecticides and applying insect repellents to the skin. Fine mesh netting may also be used. Reservoir control has been unsuccessful in most areas. Individuals with lesion should be advised to use some type of covering to protect the lesion from insect bite. Patients should be educated about the possibility of autoinoculation and infection.

### Points to remember

- Leishmania species are protozoan parasites belonging to the family Trypanosomatidae and the class Mastigophora. There are many species of Leishmania that cause infections in man. Among them *L. donovani* causes visceral Leishmaniasis or Kala Azar
- Inside vertebrate host *L. donovani* is present as amastigote forms. It infects RES, monocytes, polymorphs and endothelial cells. In sand fly and culture it is present as promastigote form.
- L. donovani* produces a disease known as Leishmaniasis. Incubation period varies from 3-6 months. The following clinical manifestations may be seen.
  - Inapparent infection
  - Kala azar
  - Unusual form of visceral Leishmaniasis
  - Cutaneous leishmaniasis

## Chapter - 8.14

### TRYPANOSOMES

#### Introduction

Since very early times, protozoan blood and tissue parasites, were responsible for many of the most savage diseases of mankind. They have crumbled civilizations, humbled armies, drained the energies of tropical people, prevented man to use vast areas of fertile agricultural lands and caused untold human misery. Two most important groups of these protozoa are the haemoflagellates and sporozoa.

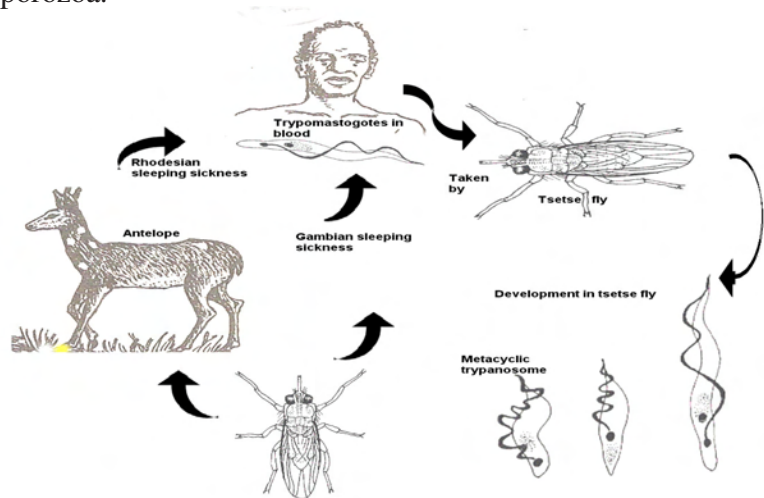


Fig. 8.14-1. Life cycle of *T. brucei gambiense* and *T. brucei rhodesiense*

#### African Trypanosomes

Trypanosomes are microscopic flagellate protozoan that infect the blood and other body fluids of humans. There are two closely related morphologically identical species of “human” trypanosomes,

*Trypanosoma brucei gambiense* and *Trypanosoma brucei rhodesiense*. Both are transmitted by several species of blood sucking fly found only in tropical Africa, of the genus *Glossina*, known as tsetse fly.

#### *Trypanosoma brucei gambiense*

This species causes West African sleeping sickness or Gambian sleeping sickness.

#### Geographical distribution

*T. brucei gambiense* is present in west and central Africa. Within this geographical location, it is restricted to forests bordering rivers and lakes around which *Glossina palpalis* lives.

#### Life cycle and transmission

Man is the only known natural host for *T. brucei gambiense*. The transmission cycle begins with the tsetse fly sucking the blood of a human infected with the parasite. Within the gut of the fly, the trypanosomes elongate and multiply by asexual division. These slender forms penetrate the gut wall, enter the body cavity, and migrate to the salivary glands. In the salivary glands, they undergo further transformation, finally becoming short, stumpy forms known as metacyclic trypanosomes. The metacyclic trypanosomes infect the new human host when introduced by the bite of the tsetse fly. The cycle in the fly takes about 15 to 30 days. The length of the time is dependent upon temperature, humidity, and age of the fly.

#### Clinical features

The Gambian sleeping sickness is chronic and malignant. After some years it gives rise to torpor and coma. This is classic sleeping sickness. Untreated patients almost always die of the infection.

During early stages Trypanosomes are present in the blood in low numbers. In this phase there is intermittent fever. Later, the parasites tend to disappear from blood and enter the lymphatics of the neck region. The cervical lymph nodes become enlarged. Still later, the organisms migrate to central nervous system and at this stage they are present in cerebrospinal fluid. At this stage neurological symptoms occur.

### Laboratory diagnosis

1. A rapid check for the presence of trypanosomes is made by examining a wet blood film
2. A thick and thin blood smears should be made and stained by Giemsa's stain for the trypanosomes
3. A small amount of blood is inoculated intraperitoneally into mice or rats. The animal blood is examined for the trypanosomes after 7 days. *T. brucei gambiense* produces low grade infection where as *T. brucei rhodesiense* follows a fulminating course and kills the animal.
4. In low grade parasitemia blood may be concentrated by centrifugation and examined.
5. In late stages CSF may be examined for trypanosomes by wet film examination and staining.

### Serological and other tests

Indirect haemagglutination test and indirect fluorescent antibody test have been used for the diagnosis.

There is a marked, more than ten times elevation of serum IgM.

### *Trypanosoma brucei rhodesiense*

*T. brucei rhodesiense* is endemic in east and central Africa and prevalent in the Savanna woodlands. Gambian trypanosomiasis is restricted to humans but Rhodesian trypanosomiasis is a zoonosis with the wild antelope of the Savanna acting as reservoir host.

### Life cycle and transmission

Lifecycle and transmission is the same as that for *T. brucei gambiense*.

### Clinical features

Gambian trypanosomiasis is a slow death for the infected human. On the other hand, *T. brucei rhodesiense* kills its untreated victim in weeks or months. It produces a fulminating parasitemia and rapidly invades the central nervous system.

### Parasitologic diagnosis

*T. brucei rhodesiense* is usually present in microscopically detectable amounts at all stages of infection except very early stage. Diagnosis can be made by wet or stained thick blood film examination.

IgM is elevated during the later stages of infection.

### Treatment and prevention:

Suramin is the drug of choice for treating the early blood or lymphatic stage of the disease. Alternatives for treating the early stage are pentamidine isothionate and DFMO (deflornithine, DL- $\alpha$ -difluoromethylornithine). Melarsoprol is the drug of choice when CNS involvement is suspected.

The most effective control measures include an integrated approach to reduction of the human reservoir of infection and the use of insecticide and fly traps. Persons visiting areas where the infection is endemic should wear protective clothing (long sleeved shirts and long trousers). Other measures include reduction in vegetation around human settlements and the use of insect repellents, bed netting and screens.

### *Trypanosoma cruzi*

*Trypanosoma cruzi* causes American trypanosomiasis or otherwise called **Chagas' disease** which is a zoonosis. Patients can present with either acute or chronic disease. A large number of patients with positive serologic tests can remain asymptomatic.

### Morphology

The **trypomastigote** is spindle-shaped, approximately 20  $\mu\text{m}$  long and characteristically assumes a C or U shape in stained blood film. Trypomastigotes occur in the blood in two forms, a long slender form and short stubby one. The nucleus is situated in the center of the body, and a large, oval kinetoplast is located at the posterior end. A flagellum arises from the basal body and extends along the outer edge of undulating membrane until it reaches the anterior end of the body, where it projects as a free flagellum. When the trypomastigotes are stained with Giemsa stain, the cytoplasm stains blue and the nucleus, kinetoplast and flagellum stain red or violet.

The **amastigote**, 2 to 6  $\mu\text{m}$  in diameter, is indistinguishable from those found in leishmanial infections. It contains a large nucleus and rod-shaped kinetoplast that stain red or violet with Giemsa stain and the cytoplasm stains blue.

### Life cycle

Trypomastigotes are ingested by the reduviid bug (triatomids, kissing bugs) as it takes a blood meal. The trypomastigotes transform into epimastigotes and multiply in the posterior portion of the midgut. After 8-10 days, metacyclic trypomastigotes are passed in the faeces. Humans contract Chagas' disease when the reduviid bug defecates while taking a blood meal and metacyclic trypomastigotes in the faeces are rubbed or scratched into the bite wound or onto mucosal surfaces. In human, *T. cruzi* can be found in two forms, amastigotes and trypomastigotes. The trypomastigote is the stage present in the blood, which infects host cell. The amastigote form multiplies within the cell, eventually destroying the cell and both amastigotes and trypomastigotes are released into the blood.

### Clinical aspects of Chagas' disease

The severity of infection depends upon the virulence of the strain of *T. cruzi* and host factor such as age and the ability to mount an immune defense. During the first six months of infection the clinical manifestation is severe and is referred to an acute phase. The patient suffers from fever, enlargement of the lymphatic glands, liver, and spleen, and damage to the heart. Children are particularly susceptible.

The acute phase leads to chronic infection in which enlargement of heart is seen. There is mechanical damage to the heart muscle cells. Progressive destruction leads to heart failure and death. Because of the destruction of the neurons of the nervous system supplying the intestinal tract, mega colon develops.

### Epidemiology

Chagas' disease is a zoonosis occurring throughout the American continent, including Central and South American continent.

### Laboratory diagnosis

1. A rapid check for the presence of trypomastigotes is made by examining a wet blood film.
2. A thick and thin blood smears should be made and stained by Giemsa's stain for *T. cruzi*.
3. A small amount of blood is inoculated intraperitoneally into Guinea pigs. The animal blood is examined for the trypomastigotes after 7 days.
4. **Xenodiagnosis:** By allowing a laboratory-bred parasite free reduviid bug to feed on an individual suspected to be suffering from Chagas disease and two weeks later examining the intestinal contents for the presence of the parasite.
5. In late stages CSF may be examined for trypomastigotes by wet film examination and staining.
6. Biopsy of an involved lymph node or muscle (calf or deltoid) may reveal the presence of amastigote forms of *T. cruzi*.

### Serologic diagnosis

Complement fixation, indirect fluorescent antibody and indirect hemagglutination tests are routinely used for the diagnosis of chronic Chagas disease.

### Treatment and prevention

Nifurtimox (Lampit) and benznidazole (radamil) reduce the severity of acute Chagas' disease. Allopurinol is effective in treating Chagas' disease. Chagas disease is controlled through

- (1) insecticides to eliminate the reduviid vector.
- (2) construction of reduviid-proof dwellings
- (3) and education.

### Points to remember

1. Trypanosomes are microscopic flagellate protozoan that infects the blood and other body fluids of humans. There are two closely related morphologically identical species of “human” trypanosomes, *Trypanosoma brucei gambiense* and *Trypanosoma brucei rhodesiense*. Both are transmitted by several species of blood sucking fly found only in tropical Africa, of the genus *Glossina*, known as tsetse fly.
2. The Gambian sleeping sickness is chronic and malignant. *Gambian trypanosomiasis* is restricted to humans but Rhodesian trypanosomiasis is a zoonosis with the wild antelope of the Savanna acting as reservoir host. *T. brucei rhodesiense* kills its untreated victim in weeks or months. It produces a fulminating parasitemia and rapidly invades the central nervous system.
3. *Trypanosoma cruzi* causes American trypanosomiasis or otherwise called **Chagas’ disease** which is a zoonosis. Patients can present with either acute or chronic disease.

## Chapter - 8.15

# Parasitic helminthes

## *Fasciola hepatica*

### Introduction

The parasitic worms, or helminthes, which occur in humans comprise 4 major groups. They are

1. flatworms (phylum Platyhelminthes), the trematodes or digeneans (flukes)
2. cestodes (tapeworms),
3. the nematodes (or roundworms; phylum Nematoda) and
4. the acanthocephalans (or thorny-headed worms; phylum Acanthocephala).

A direct life cycle is one in which the final host is reinfected directly without the involvement of intermediate hosts. An indirect life cycle is one in which intermediate hosts or paratenic hosts harbour one or more life history stages. The final or definitive host harbours the adult (sexual adult in the case of the Digenea). Intermediate hosts are those in which one or more larval stages develop as a necessary part of the life cycle. A paratenic host is one in which larval stages may survive but do not normally develop; they are often not a necessary part of the life cycle.

### Phylum Platyhelminthes (Trematodes and Cestodes)

The platyhelminths or flatworms are bilaterally symmetrical, dorsoventrally flattened worms with a definite head end and lacking a body cavity. They include a variety of free-living turbellarians, which occur in aquatic and terrestrial conditions (a small number are parasitic), and a number of entirely parasitic groups. These comprise 3 classes: the



Monogenea (mainly ectoparasites of fishes); the Cestoidea (tapeworms; endoparasites); and the Trematoda (endoparasitic flukes; mainly digeneans). Only the latter 2 classes infect humans.

Trematodes (flukes) (Phylum- Platyhelminthes, Class: Trematoda) are non segmented, flat worms, usually leaflike, with one or more suckers by which they attach to their host tissues (the oral suckers surrounding the mouth). They vary in size from a few millimeter to large fleshy species such as *Fasciola*. Their bodies are covered by a cuticle without epidermis or external cilia. The digestive tract consists of a mouth, pharynx and usually a bifurcated intestine. With the exception of the family Schistosomatidae, they are monocious (both sexes are in the same individual) and produce operculated eggs.

### Class Cestoidea

Main features. Platyhelminthes. Primarily intestinal parasites of vertebrates. Usually with single generation in life cycle and sexual adult in vertebrate; rarely with asexual reproduction in intermediate host. Life cycle is invariably indirect (one exception); wide variety of invertebrates and vertebrates used as intermediate hosts. Adult is segmented or not; with duplication of reproductive organs along body (polyzoic) or not (monozoic); segmented forms polyzoic; and unsegmented forms are monozoic or polyzoic. Distinct scolex (head) is present or absent. Syncytial tegument is usually but not always unarmed (at light microscope level) and gut is absent.

The cestodes, or tapeworms, occur as intestinal parasites of all groups of vertebrates. Their closest relatives are the monogeneans, ectoparasitic flukes mainly of fishes, from which they are likely to have been derived. There are 2 subclasses, the Cestodaria, which are monozoic forms, lacking a scolex (head) and parasitic in fishes and turtles, and the Eucestoda, the majority of which are segmented and polyzoic. Only the latter subclass parasitizes humans.

The trematodes or 'flukes' are flatworms which originally evolved as parasites of molluscs and virtually all species retain a

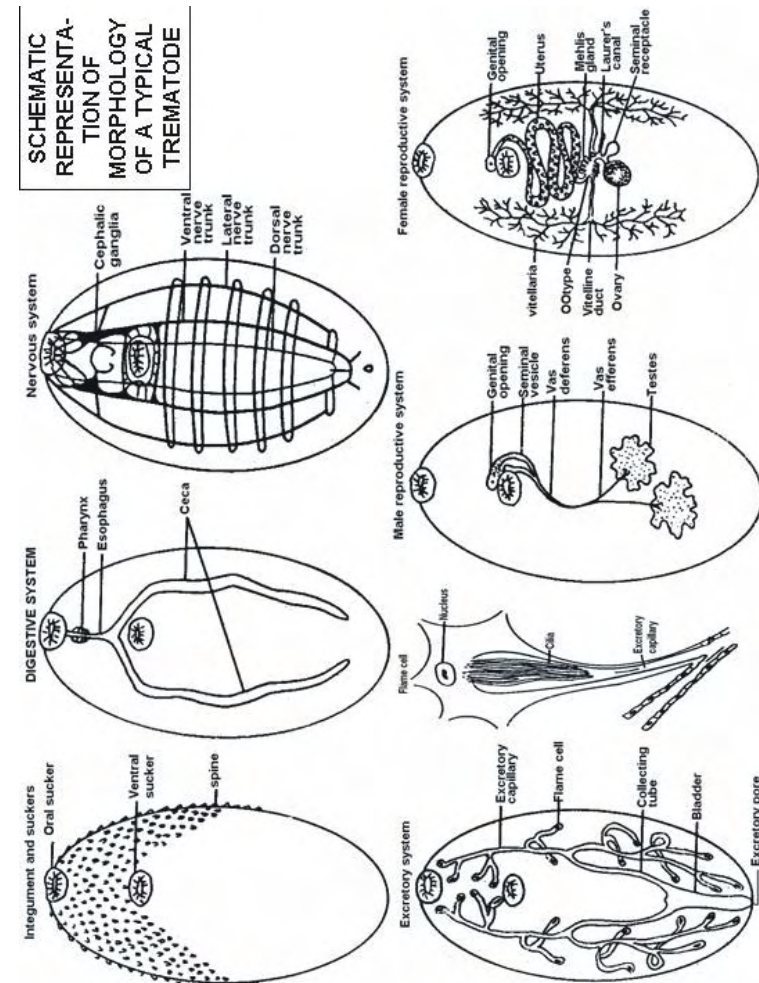


Fig. 8.15-1. Parasitic Helminthes

molluscan element in their life history. There are 2 subgroups, the Digenea and the Aspidogastrea, but only the former occurs in humans and other mammals.

### Characteristics of Trematoda

They are non segmented flat worms and have leaf like appearance. They attach to the host with one or two suckers. They possess two groups of suckers, the oral suckers which surround the mouth and ventral suckers. The size of the worms varies from few millimeters to large fleshy species Fascioloides and Fasciola. Their bodies are covered with a cuticle without epidermis or external cilia. The digestive system consists of a mouth, pharynx and bifurcated intestine, with the exception of family Schistosomidae, they are monocious. Both sexes are present in the same individuals.

### Fasciola hepatica

Sheep, cattle, watercress, and snails are some of the main elements contributing to the epidemiology of the two closely related flukes, *Fasciola hepatica* and *Fasciola gigantica*. These parasites inhabit liver and bile ducts. They are the largest trematodes to infect humans. *F. gigantica* is a monster fluke, attaining a length of 5 cm and *F. hepatica* approximately 3 cm in length.

### Geographical distribution

Humans are only accidental hosts of *Fasciola hepatica* and *F. gigantica*. *F. hepatica* is normally a parasite of sheep and *F. gigantica* is a parasite of cattle. The infection is more common in these domestic animals where they are grazed in boggy meadows near ponds or in which watercress and other aquatic plants grow. Human infections with *F. hepatica* occur in sheep-raising areas.

### Life cycle and transmission

The adult fluke lives within the intrahepatic portion of the bile duct system. They lay unembryonated eggs, which take about 14 days to mature after they have been passed with the feces into a suitable water environment. When maturation is complete the operculum opens

## Fasciola hepatica

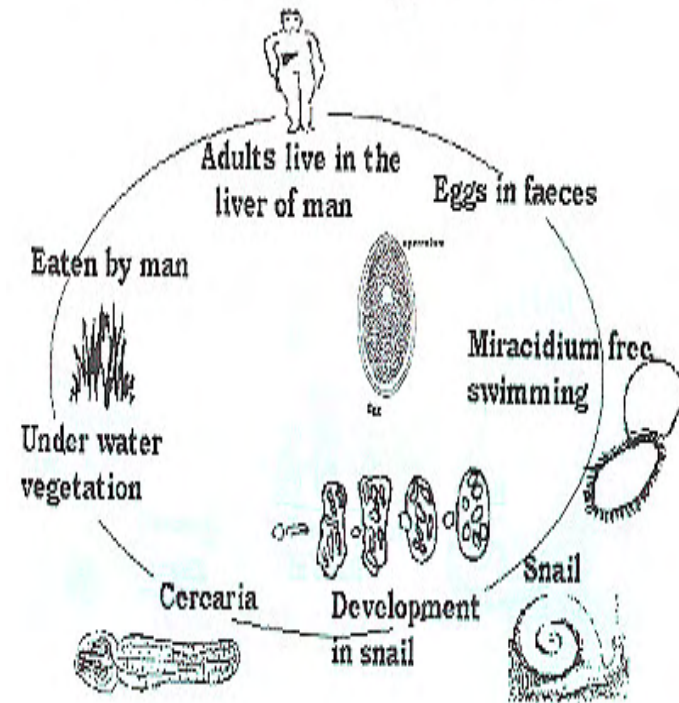


Fig. 8.15-2. Life cycle of *Fasciola hepatica*

and the miracidium is released. *F. hepatica* miracidium seeks a suitable snail host. In the molluscan tissue, it undergoes the typical trematode asexual reproductive process. The biological phase is completed in about 40 days with the release of the tadpolelike cercariae. The second intermediate host is not a host in the conventional sense since it does not involve metacercarial development within crab, fish, or other animal tissues.

Instead, the Fasciola cercaria attaches itself to an aquatic plant or crawls onto a blade of grass near the water's edge. On the plant surface the cercaria takes on a round shape and secretes a protective cyst wall around itself. Transformation to the mature, infective metacercaria takes about 6 months. Transmission occurs when the definitive host (cow, sheep or human) ingests the infective metacercaria. Humans become infected when they partake of a watercress- metacercaria salad or ingest the parasite when biting away the skin of contaminated water chest nut. After it has entered the body of the definitive host, the metacercarial cyst wall is dissolved in the duodenum. The minute larval fluke is released and begins its journey by penetrating the intestinal wall to enter the peritoneal cavity. It wanders about the peritoneal cavity until it reaches the surface of the liver. It invades the liver and migrates through the hepatic tissues for about a month until it arrives at bile ducts where growth into the sexually mature adult takes place. The adult fluke begins to lay his/her eggs (Fasciola is a hermaphrodite), two to three months from the time it was ingested as a metacercaria.

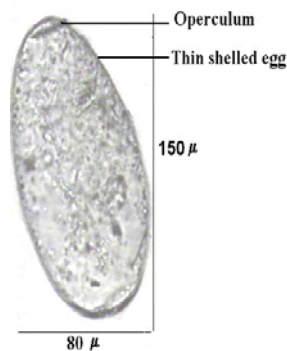


Fig. 8-15-3. Fasciola hepatica - egg

### Clinical findings :

Infection with *F. hepatica* or *F. gigantica* is known as Fascioliasis. In mild infections Fascioliasis may be asymptomatic. Infection with large number of flukes can be so severe and may cause death of

the host. In the early stages hemorrhage and necrosis of the liver tissues occur due to the migration of the young flukes. At this stage fever, abdominal pain, eosinophilia and diarrhea occur. Once adults are established in the bile ducts, these symptoms may disappear but abdominal pain and attacks of fever and nausea may persist for years. In heavy infections fluke induced fibrosis of the bile duct may lead to obstructive jaundice.

### Laboratory diagnosis

#### Treatment prevention and control

For infection with Fasciola species, bithionol and hexachloroparaxylene are effective. Triclabendazole is found to be highly effective against adult and immature stages of *F. hepatica*.

An important preventive measure is to educate the public regarding the mode of transmission of the parasite and the dangers of eating uncooked, contaminated vegetables. Prevention of fecal contamination of waters used for plant growing where infected sheep and cattle or swine and humans are present is also essential.

### Points to remember

1. The platyhelminths or flatworms are bilaterally symmetrical, dorsoventrally flattened worms with a definite head end and lacking a body cavity. Trematodes (flukes) (Phylum-Platyhelminthes, Class: Trematoda) are non segmented, flat worms, usually leaflike, with one or more suckers by which they attach to their host tissues (the oral suckers surrounding the mouth).
2. Sheep, cattle, watercress, and snails are some of the main elements contributing to the epidemiology of the two closely related flukes, *Fasciola hepatica* and *Fasciola gigantica*.
3. These parasites inhabit liver and bile ducts. Infection with *F. hepatica* or *F. gigantica* is known as Fascioliasis. In heavy infections fluke induced fibrosis of the bile duct may lead to obstructive jaundice.
4. Stool specimen is examined for the presence of ova.

## Chapter - 8.16

# TAENIA SOLIUM (Taeniasis, pork tapeworm infection)

### Class Cestoidea

#### Main features of Platyhelminthes.

They are primarily intestinal parasites of vertebrates. Usually they have single generation in life cycle and sexual adult in vertebrate; rarely with asexual reproduction in intermediate host. Life cycle is invariably indirect (one exception); and a wide variety of invertebrates and vertebrates are used as intermediate hosts. Adult is segmented or not; has duplication of reproductive organs along body (polyzoic). Distinct scolex (head) is present or absent. Syncytial tegument is usually but not always unarmed (at light microscope level). Gut is absent. Two important species viz. *Taenia solium* and *Taenia saginata* cause taeniasis in human. Infection caused by *T. solium* is called pork tape worm infection and by *T. saginata* is called beef tape worm infection.

#### General features of Tape worms

Tapeworms lead a complex developmental life, and most species have one or more intermediate host in which the larval stage(s) lives. Adult tape worms are gutless flatworms that absorb nutrient directly through the integument. The tape worm is made up of chain of segments. The first segment is called the head or scolex. It has specialized structures called suckers.

These suckers are in some species armed with hooks to anchor the worm to the host's intestinal wall. The scolex is also the germinal center from which all other segments arise. A tape worm segment is called a proglottid. Near the neck of the scolex the proglottids are sexually immature, in the middle of the chain they are sexually functional mature proglottids and at the end of the chain they are mere sacs of eggs called gravid proglottids.

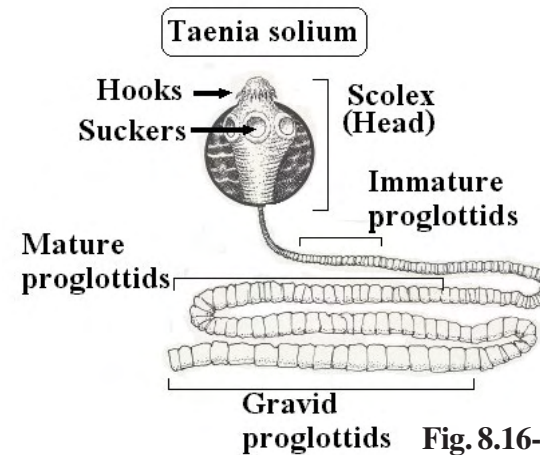


Fig. 8.16-1. Taenia solium

#### Geographic distribution

*Taenia solium* infections occur in countries where pigs are raised, sanitation is poor and pork or pork products are eaten raw or undercooked. It is endemic throughout Latin America, tropical Africa, South East Asia and in the Indian subcontinent.

#### Life cycle and transmission

The adult tapeworm, about 10 feet in length, lives in the human small intestine. Eggs and gravid proglottids are passed with the faeces. The pig eats food contaminated with human faeces and ingests the eggs. The oncosphere hatches from the egg and enters the blood system en route to the muscles and other tissues where a fully developed cysticercus matures in two or three months. The pig may be so heavily infected that its meat looks as if it was seeded with the translucent bladders, a condition known as mealy pork. When a man eats the pork and three months later he acquires a complete worm. The worms can live for up to 25 years.

#### Clinical manifestations

Most infections cause little discomfort. Majority of the patients are unaware of the worm within. Some patients complain of abdominal discomfort, hunger pains, and episodes of diarrhea alternating with periods of constipation.

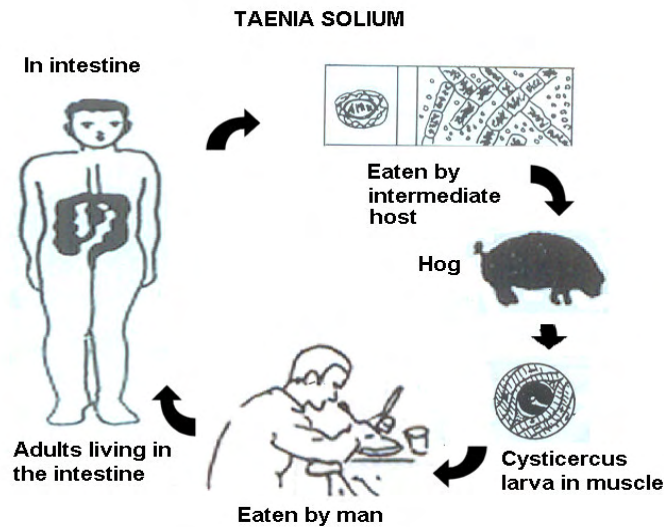


Fig. 8.16-2. *Taenia Solium*

### Laboratory diagnosis

Diagnosis depends on identifying the eggs or proglottids in the stool. Recovery of scolex may also be required. Twenty feet worm may be removed by the drug but if 3-mm head remains alive and attached to the intestinal wall it can in time regenerate an entire new tapeworm.

Eggs can be concentrated from the stool by both sedimentation and flotation techniques. If proglottids are found in the stool, species identification is done by counting uterine branches.

Indirect hemagglutination test is used as a serodiagnostic test for Taeniasis.

### Cysticercosis

Eggs passed in the faeces if ingested by cattle, pig or man, the intermediate hosts, the eggs develop into larval (cysticercus) stages. This disease is termed cysticercosis.

Human to human transmission occurs in the following ways: 1. Autoinfection of humans can occur with *T. solium* eggs transmitted directly from anus to mouth. 2. Transmission can occur between

individuals through contaminated hands or food. 3. Internal autoinfection whereby gravid proglottids enter the stomach via vomiting or reverse peristalsis can also occur. 4. Humans most commonly become infected like pigs through the ingestion of *T. solium* eggs contaminating the environment viz drinking water contaminated with inadequately treated sewage or eating vegetables fertilized with raw sewage.

*T. solium* cysticerci develop in muscle tissues and show few symptoms. The cysts can occur in the eye. Most commonly the cysts are present in vitreous humor and subretina and the inflammatory response can lead to retinal detachment and blindness. Myocardial cysticercosis frequently occurs in massive infections. Involvement of central nervous system can cause serious clinical disease resulting from either an inflammatory response or an obstruction.

### Treatment

Niclosamide and praziquantel are effective for human taeniasis. Praziquantel has the advantage in that it effectively removes the scolex and causes destruction of strobila with out release of gravid proglottids. It is also effective in human cysticercosis

### Control

Eradication may be achieved in beef and pork through mandatory and improved surveillance procedures at slaughter. Eradication is attempted in humans through screening and drug therapy. Ultimately, by improvements in sanitary and economic conditions and in public health education the disease can be controlled.

### Points to remember

1. *Taenia solium* is a cestode parasite which causes taeniasis and cysticercosis in human. Humans act both as definitive and intermediate host for this parasite.
2. Adult worm causes taeniasis when it lives in the intestine. Larval stage causes cysticercosis where cysticerci can be present in muscles, heart, and CNS.
3. Niclosamide and praziquantel are used for treatment.
4. Improvements in sanitary and economic conditions and public health education are necessary for effective control of the disease.

## Chapter - 8.17

### CANDIDA ALBICANS

The genus *Candida* is yeast like fungi. The yeasts are spherical, oval or elongated and reproduce by budding. The buds usually separate from the mother, but sometimes some buds remain attached. In such cases, when the cells are elongated, the terminal bud becomes longest and the yeast cells appear elongated. This form is called a *Pseudomycelium*. The yeasts which produce pseudomycelium are usually called Yeast like fungi. There are several species in nature and they cause many diseases in man, but 90% of the infections are caused by *Candida albicans*.

*Candida albicans* is normally present in the mouth, intestine and vagina. When the immunological conditions and defense mechanisms are compromised, it causes infections in the sites it is present and also else where in the body.

*Candida albicans* is thin walled, non-capsulated, oval yeast with or without bud which produces pseudomycelium in the body and in the culture when the aeration is poor. In nutritionally poor media, at temperatures below 26°C it produces thick walled chlamydospores, and it also produces curved elongated germ tube when transferred to mammalian serum from a peptone containing medium at 37°C. The yeast cell and the pseudo mycelium are stained by Gram's method (Gram positive).

*Candida albicans* grows well on Sabouraud's medium and on Blood agar. Its growth characteristics in other media, assimilation pattern, fermentation of carbohydrates and failure to split urea are some of the characters to differentiate from other *Candida* species. *Candida albicans* is not sensitive to antibacterial antibiotics. *Candida albicans* is pathogenic for rabbits, guinea pigs, and mice.



Fig. 8.17-1 Pseudomycelia

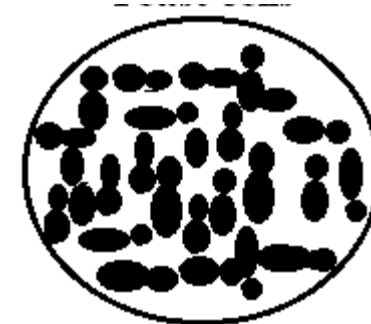


Fig. 8.17-2 Yeast cells

### PATHOGENESIS

*Candida albicans* causes infection when the defense mechanisms and the immunological conditions of the body are suppressed. So the infection by *Candida albicans* is also known as opportunistic infection. *Candia* is present in the healthy and moist areas of the skin. Infections of the mucus membrane are known as thrush. The infections may be of different types. When it causes infection in the vagina, it is called vaginitis or vaginal thrush. Pregnant women are affected more. There is whitish discharge with the pH below 5.2. If observed under microscope some pus cells and many yeast cells with pseudomycelia can be seen.

### Clinical Manifestations:

#### Cutaneous and Mucosal Candidiasis:

The superficial candidiasis is seen in the normal persons. AIDS, pregnancy, diabetes, young and old age, birth control pills and trauma are the risk factors associated with candidiasis.

Oral thrush occurs on the tongue, lips, gums or palate. It is a white patch with epithelial cells, yeast and pseudo hyphae. Oral thrush develops in most of the AIDS patients.

*Candida* invades the mucosa of the vagina and causes vulvo vaginitis which is characterized by irritation, pruritis and vaginal

discharge. This alters the microbial flora, local acidity or secretions.

*Candida* invades the skin and causes infection in the moist, warm parts of the body such as the axillae, groin and intergluteal folds. The infected area becomes red and moist and may develop deep vesicles. Interdigital involvement is most common in home makers, cooks, vegetable and fish handlers. It also causes infection of the nails and around the nail plates and is called onychomycosis, a painful, erythematous swelling of the nail fold.

### **Systemic Candidiasis:**

In normal persons if candidemia occurs, normal host defences eliminate candida. But candida invades blood stream in persons after surgery, intravenous drug abuse and in indwelling catheter patients. Systemic candidiasis is associated with chronic administration of corticosteroids or other immunosuppressive drugs. *Candida* causes endocarditis and also kidney infections, whereas urinary tract infections are often associated with catheters, diabetes, pregnancy and antibacterial antibiotics. In cellular immuno deficiency persons, candida causes chronic mucocutaneous infection from early childhood. There is no specific site for candida infection in the body.

### **LABORATORY DIAGNOSIS**

Swabs are used to collect the specimen from the infected areas. Exudates, sputum and faeces are also collected. *Candida* may be demonstrated in wet preparations. Smears are made and Gram stained and observed under microscope.

**Culture:** The specimens are inoculated onto Sabouraud's medium or on Blood agar. *Candida albicans* is differentiated from other *Candida* species by the colony morphology and Germ tube test. The production of pseudomycelium separates *Candida* from other genera and the assimilation of sugars differentiates it from other species of *Candida*. The interpretation of the results depends on the comparison of the number of organisms. A small number of yeasts in a single specimen of vaginal discharge cannot be considered.

Serological tests have no significance. Patients with chronic *Candida* infections and healthy members may have similar level of antibodies in the serum.

### **TREATMENT AND PREVENTION:**

As the *Candida* species cause opportunistic infections, the underlying cause for the infections must be identified. If the underlying conditions are like poor hygiene or diabetes, they can be corrected and the body takes care of candida. Polyene anti fungal agents or nystatin can be applied locally. For systemic infections Amphotericin-B with 5-Fluorocytosine or with Clotrimatazole can be given.

Since this is an endogenous infection, it cannot be prevented by immunization but the frequency can be made less by good medical practice and avoiding long term use of antibacterial antibiotics and immunosuppressive drugs. Cross infections can be controlled by avoiding contacts with infected persons and infected dusts.

### **Points to remember:**

1. *Candida* is yeast like fungus which produces pseudomycelium. There are several species in nature and they cause many diseases in man. The important species is *C. albicans*.
2. *Candida albicans* causes infection when the defense mechanism and the immunological conditions of the body are suppressed.
3. Vaginitis, oral thrush, skin and pulmonary infections are some of the infections caused by *C. albicans*.
4. *Candida* infections are diagnosed by Gram stain of the direct smears and by culture on Sabouraud's agar and biochemical identification.

## Chapter - 8.18

### CRYPTOCOCCUS NEOFORMANS

The genus *Cryptococcus* of yeasts produces no pseudomycellium and differs from *Candida* in this aspect. There is only one pathogenic species which is known as *Cryptococcus neoformans*. It is a spherical yeast with a capsule of various thickness. It reproduces by budding. The cell measures from 5-20  $\mu\text{m}$  in diameter and the capsule can be well seen in wet, India ink preparations. It is stained by Gram method [Gram positive].

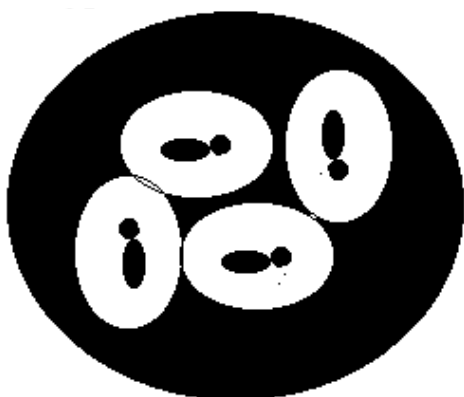


Fig. 8.18-1 *Cryptococcus neoformans*

*Cryptococcus neoformans* causes cryptococcosis which is a disease of the CNS, although the primary site of infection is the lungs. The disease occurs throughout the world but it is now seen most often in AIDS patients.

#### Clinical Manifestations

Meningitis is the main form of the disease but initially it causes infection in lungs.

#### Pathogenesis

The organism enters into the body through inhalation and reaches deep into the lung. The disease is more common in men than women. A mild pulmonary infection is the commonest form of cryptococcosis. There are no clear diagnostic features in symptomatic pulmonary infection. Lesions are formed, some may heal and some may become enlarged and encapsulated. An acute pneumonic type of disease has also been described.

Meningeal form of cryptococcosis may occur in healthy individuals also but it occurs in patients with abnormalities of the lymphocyte function. Around 3 – 20 % of individuals with AIDS develop cryptococcosis. Initially chronic meningitis or meningoencephalitis develops, with headache and low grade fever followed by changes in mental state, anorexia, visual disturbances and finally coma. The disease may last from a few months to several years and is fatal always unless treated. It produces chronic meningeal form in AIDS patients. Even though a disease of the CNS, it produces lesions on the skin, mucosa, viscera and bones. Sometimes it resembles tuberculosis and rarely it produces lesions on the skin and bones without any evidence of the infection.

*Cryptococcus neoformans* causes cryptococcosis which is a disease of the CNS.

#### Laboratory Diagnosis

Direct Microscopy and staining: CSF can be used for direct examination. In AIDS patients the yeast cells are more in number. The yeast cells of *C. neoformans* are round, 4 – 10  $\mu\text{m}$  in diameter and are surrounded by a mucopolysaccharide capsule. CSF is mixed with a drop of India ink or nigrosine and observed under the microscope. The capsule can be seen as a clear halo around the yeast cells.

Sputum, pus or brain tissues should be digested in potassium hydroxide before examination. For the examination of tissue sections, special fungal stains like PAS can be used. Alcian blue and mucicarmine stain the capsular material and is useful to differentiate *C. neoformans* from other capsulated organisms.



## Culture

The yeast cell is cultured on Sabouraud's agar at 25 – 30° and 37°C. Colonies appear in 2 – 3 days but culture should be kept for 3 weeks. In culture, *C. neoformans* appear as creamy white to yellow brown colonies and some are mucoid with well developed capsules and some may be dry which lack prominent capsules. Buds appear at any point on the cell surface but mycelium or pseudomycelium are not produced. Direct demonstration of capsulated yeast cells in CSF is the preliminary identification. It is confirmed by its ability to produce the enzyme urease.

## Antigen detection

Latex agglutination test is used for the detection of capsular polysaccharide antigen in CSF or blood. This test is highly specific and sensitive for the detection of cryptococcal meningitis and gives better results than microscopy and culture. In AIDS patients over 90 % shows positive by this test. ELISA can also be used for the detection of antigen.

## Antibody detection

A whole cell agglutination test for serum antibody is in less than 50% of the proven cases of Cryptococcal meningitis. This is because the antibodies are neutralized by antigen released during infection. Antibodies may reappear after treatment in the normal persons but not in the AIDS patients.

## Treatment

Immunocompetent persons are treated with oral fluconazole or itraconazole. For immunocompromised persons amphotericin B in combination with flucytosine is given intravenously. AIDS patients usually relapse after the initial course of therapy and may react badly to the drugs.

## Control

Individuals at risk of developing cryptococcosis should avoid contact with birds.

## Points to remember

1. The yeast cells of *C. neoformans* are round, 4 – 10 µm in diameter and are surrounded by a mucopolysaccharide capsule.
2. *Cryptococcus neoformans* causes cryptococcosis which is a disease of the CNS. Meningitis is the main form of the disease but initially it causes infection in lungs.
3. It produces chronic meningeal form in AIDS patients. Even though a disease of the CNS, it produces lesions on the skin, mucosa, viscera and bones.
4. Latex agglutination test is used for the detection of capsular polysaccharide antigen in CSF or blood. This test is highly specific and sensitive for the detection of cryptococcal meningitis.

## Chapter - 8.19

### MYCETOMA

Mycetoma is a chronic suppurative granulomatous sub-cutaneous infection with multiple discharging sinuses. This is otherwise known as fungal tumour. Usually it occurs in the foot and it is known as Madura foot. Other parts of the body like hand, neck, shoulder and head are also affected.

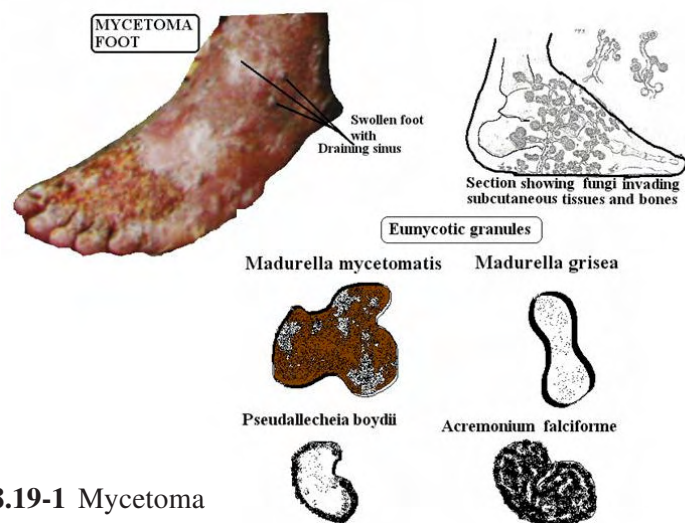


Fig. 8.19-1 Mycetoma

This is caused by two types of organisms. They are, 1. Actinomycotic agents, 2. Eumycotic agents. The actinomycotic agents are (a) *Nocardia* spp. (b) *Streptomyces* spp. (c) *Actinomyces*. Eumycetoma is caused by true fungi. They are (d) *Madurella mycetomatis* (e) *Madurella grisea* (f) *Pseudallescheria boydii* (g) *Acremonium falciforme* (h) *Exophiala jeanselmei*. There are some other fungi which also cause mycetoma infrequently (i) *Curvularia lunata* (j) *Curvularia geniculata* (k) *Penicillium mycetogenum* (l) *Fusarium solani*

### PATHOGENESIS:

The fungi are inhabitants of soil and vegetation. The causative agent enters through minor trauma. The disease usually begins as a small subcutaneous swelling of the foot, which enlarges, burrowing into the deeper tissues. It opens out through multiple sinuses discharging fluid with granules. The granules are micro colonies of the organism. The colour and consistency of the granules vary with the different agents.

S. No	Eumycetes	Actinomycetes
1	The hyphae size ranges from 2-10 $\mu\text{m}$	The filaments size range from 1-2 $\mu\text{m}$
2	The cell wall contains chitin, glucan and mannan	The cell wall contains peptidoglycan
3	There is definite nucleus	Only nuclear area
4	The cytoplasm contains mitochondria and endoplasmic reticulum	Not present
5	Usually reproduction by spore formation	By binary fission and fragmentation
6	Eumycetoma is caused by higher fungi	Actinomycetoma is caused by higher bacteria
7	Antibiotics are not very successful. Amputation is done sometimes	Antibacterial antibiotics are useful for treatment.

### LABORATORY DIAGNOSIS

#### SELECTION OF SPECIMEN

1. Pus is collected with granules
2. Swabs from deeper parts of the infection
3. The scrapings of the deeper parts [superficial parts may be contaminated with bacteria]
4. Biopsy material
5. Dressings which contain drained pus.

## TRANSPORT

Specimen should be placed in a sterile container, promptly transported to the laboratory to avoid contamination. The granules should be washed with sterile saline repeatedly to remove the bacteria.

Colour, size, consistency, microscopical appearance of granules should be noted.

## DIRECT EXAMINATION:

Granules are crushed and examined in saline and KOH.

## STAINING:

Gram stain: The granules are crushed, fixed and Gram stained. The filaments are Gram positive. From the size of the filament it is known whether it is Eumycotic or Actinomycotic granules.

## MORPHOLOGY OF EUMYCOTIC GRANULES:

*Madurella mycetomatis*: The granules are black in colour. They are made up of filaments which are found in cement like substances. They are uniformly pigmented.

### **Madurella greisea:**

The granules are black and are pigmented only at the periphery and the centre is hollow with pale hyphae. Cement is present only in ring.

### **Pseudo allacheria boydii:**

The granules are white or yellow in colour. The hyphae are broad septate seen at the periphery, they have club shaped ends.

*Acremonium falciforme* the granules are white or yellow, soft with hyaline hyphae. No cement substance is seen.

*Exophiala jeanselmi* the granules are black or dark brown in colour. They are elongated and soft. They look like worm cyst.

## ACTINOMYCOTIC GRANULES:

White or yellow or pink granules are produced by them.

For isolation SDA medium with or without antibiotics is used. The plates are incubated at room temperature and 37°C.

Biochemical tests are used mainly for *Nocardia* and *Streptomyces* species.

Animal pathogenicity is done for *Nocardia* species for which Swiss mice are used.

## CULTURES:

Samples should also be cultured at 25-30°C and 37°C, on Brain heart infusion agar or blood agar for Actinomycetes and on Sabouraud's agar for Eumycotic agents. The fungi that cause eumycetoma are all septate moulds. They appear in culture within 1 to 4 weeks. Serological precipitin tests are used to differentiate between eumycetoma and actinomycetoma and also to identify the specific organisms. But they are of little value for diagnosis in routine use.

## TREATMENT:

Eumycetoma does not respond to chemotherapy and radical surgery is usually necessary. For the cutaneous form treatment with potassium iodide is satisfactory. In disseminated disease intravenous amphotericin B is required.

## EPIDEMIOLOGY AND CONTROL:

Organisms producing mycetoma occur in soil and on vegetation. Barefoot farm labourers are most exposed. Proper cleaning of wounds and wearing shoes are reasonable control measures.

### Points to Remember

1. Mycetoma is a chronic, suppurative subcutaneous fungal infection. Two types of the organisms cause the infection, they are actinomycotic agents and eumycotic agents.
2. Different types of granules are seen in the mycetoma. They are collected, cleaned, washed and crushed for diagnostic purposes. When stained with Gram's staining, they become Gram positive.
3. Eumycotic mycetoma does not respond to chemotherapy.
4. Mycetoma producing organisms occur in soil and on vegetation.
5. Wearing of shoes while doing gardening is a reasonable control measure.

## Chapter - 8.20

### HERPES VIRUSES

The herpes viruses, a large family infecting many animal species, including humans, share a number of features, like structure, mode of replication, capacity to establish lifelong latent infection and re-activation.

At present there are eight human herpes viruses have been shown to be common in all populations. Studies with the eighth are awaited.

1. Herpes Simplex virus 1	HSV – 1
2. Herpes Simplex virus 2	HSV – 2
3. Varizella – Zoster virus	VZV
4. Epstein – Barr virus	EBV
5. Cytomegalo virus	CMV
6. Human Herpes virus 6	HHV – 6
7. Human Herpes virus 7	HHV – 7
8. Human Herpes virus 8	HHV – 8

#### STRUCTURE:

The Herpes virus is icosahedral, composed of 162 hollow hexagonal and pentagonal capsomeres. The core of double stranded DNA, in the form of a toroid is found in all herpes viruses and is surrounded by the icosahedral capsid. The nucleocapsid is surrounded by a lipid envelope derived from the infected cell's nuclear membrane. Viral glycoprotein spikes measuring 8nm in length are present on the surface of the envelope. An amorphous structure, containing several proteins found between the envelope and capsid is designated the tegument. The enveloped virion measures 120-200 nm; and the naked virion, measures 100nm.

#### CLASSIFICATION:

Classification of the numerous members of the herpes viridae is complicated.

##### 1. Alpha herpes viruses:

They are growing fast with a relatively short replicating cycle (12-18 hours) and are Cytolytic with a variable host range. They tend to establish latent infection in sensory nerve ganglia. Eg. HSV 1 & 2, VZV.

##### 2. Beta herpes viruses:

They are slow growing viruses with a long replicating cycle (more than 24 hours) and have a narrow host range. They tend to produce enlargement of infected cells (cytomegaly) and cause latent infection of salivary glands and kidneys. Eg. EBV & HHV 8.

#### HERPES VIRUS REPLICATION:

Herpes viruses multiply inside the nucleus of the infected cells. The series of events are described as follows. The glycoprotein spikes attach to the specific receptors present on the surface of the host cell. After attachment, the viral envelope fuses with the cell membrane. The nucleocapsid is transported through the cytoplasm to the nucleus. Uncoating occurs and the DNA becomes associated with the nucleus. Replication of viral DNA takes place within the nucleus. The viral capsid proteins are synthesized in the host cell cytoplasm, later migrate from the cytoplasm to the nucleus, where capsid assembly occurs and a new viral DNA is inserted and located in the inner shell. Viral glycoprotein spikes are processed in the golgi complex and incorporated into the inner layer of nuclear membrane from which the viral envelope is acquired. Mature viral particles are transported to the cell surface by membranous vacuoles and released. The length of replication cycle varies from 18-72 hours depending on the virus type. Cells productively infected with herpes viruses generally do not survive.

#### HERSPES SIMPLEX VIRUS

Herpes Simplex viruses are extremely widespread and are highly cytolytic. The Herpes Simplex viruses are responsible for a spectrum

of diseases ranging from gingivostomatitis to keratoconjunctivitis, encephalitis, genital diseases and infections of new born. They establish latent infections in trigeminal and sacral nerve ganglia, and recurrences are common.

### **TYPES:**

There are two types of HSV namely HSV 1 (HHV type 1) and HSV 2 (HHV type 2). The two viruses cross react serologically. They differ in their mode of transmission. HSV 1 spreads by direct contact, usually involving infected saliva or droplet spread from cases or carriers. HSV 2 is transmitted sexually or from a maternal genital infection to new born. This results in different clinical features of human infection.

### **PATHOGENESIS:**

Primary infection is usually acquired in early childhood between 2-5 years of age. Primary HSV infections are usually mild; in fact most of them are asymptomatic. HSV is transmitted by the contact of a susceptible person with an individual excreting virus. The virus enters mucosal surfaces or broken skin, multiplies locally with cell to cell spread. Then it invades local nerve endings and is transported to the dorsal root ganglia. After further replication in the ganglia, latency is established. Antibodies may not prevent recurrences but can reduce the severity of the clinical disease. Cell mediated immunity is more important in resistance and recovery from HSV infections. HSV diseases are more frequent and severe in AIDS patients. Generally HSV 1 produces 'above the waist' and HSV 2 'below the waist' lesions but the rule is not absolute. HSV 2 infection confers some protection against HSV 1 but not vice versa.

### **Latent infection:**

Following asymptomatic/symptomatic primary infection, virus resides in latently infected ganglia in a non-replicating state for the life of the host. Proper provocative stimuli like fever, stress, and exposure to UV and axonal injury can reactivate the virus from the latent state; the virus is transported back to the peripheral site and replication proceeds at the skin or mucous membranes.

### **Clinical Manifestation:**

#### **Oropharyngeal diseases:**

Primary HSV -1 infections are usually asymptomatic. Symptomatic infection is common in children (1-5 years) and involves the buccal and gingival mucosa of the mouth. Symptoms include fever, sore throat, vesicular and ulcerative lesions, edema, gingivostomatitis and gingivitis.

In adults, HSV1 causes pharyngitis and tonsillitis. Recurrent disease is characterized by a cluster of vesicles most commonly localized at the border of the lips.

#### **Skin and cutaneous infections:**

**Traumatic herpes:** Localized lesions caused by HSV – 1 or HSV – 2 may occur in aberrations that become contaminated with the virus.

**Herpetic whitlow:** An occupational disease seen on fingers of dentists and hospital personnel.

**Herpes gladiatorum:** In this condition lesions are seen on the bodies of wrestlers.

Eczema herpeticum is a primary infection, usually with HSV – 1 in a person with chronic eczema. Crops of vesicles appear on the affected area with widespread ulceration. In rare instances the illness may be fatal.

Fever blister or herpes febrilis is due to viral reactivation in fever patients.

**Eye infection:** HSV infection is the most common cause of corneal blindness in some developed countries.

Acute keratoconjunctivitis is a primary infection with HSV -1 in the eye. In Follicular conjunctivitis vesicle formation is seen in the lids.

**Keratitis:** Recurrent lesions of the eye are common and appear as dendritic keratitis or corneal ulcers or as vesicles on the eye lids.

**Blindness:** Recurrent keratitis with progressive involvement of the corneal stroma may lead to permanent opacification and blindness.

**Encephalitis:** HSV – 1 encephalitis is considered as the most common acute encephalitis in most parts of the world. HSV can cause sacral autonomic dysfunction, Guillain-Barre syndrome and Bell's palsy.

**Genital herpes:** Genital disease is more frequently caused by HSV – 2, although HSV -1 can also cause genital herpes. Genital herpes is characterized by vesiculo-ulcerative lesions of the penis of the male or of the cervix, vulva, vagina and perineum of the female

### **LABORATORY DIAGNOSIS:**

The diagnosis of the herpes virus infection may be made by microscopy, antigen or DNA detection, virus isolation, serology.

#### **Microscopy**

The Tzanck smear is a rapid, fairly sensitive and inexpensive diagnostic method. Smears are prepared from the base of the vesicles and stained with 1% aqueous toluidine blue for 15 seconds. Multi-nucleated giant cells, faceated nuclei with ground glass chromatin (Tzanck cells) are seen in a positive smear.

Intra nuclear type A inclusion bodies may be seen in Giemsa's stained smears.

The herpes antigen may be demonstrated in smears or sections from lesions by the fluorescent antibody technique.

#### **Isolation**

Virus isolation remains the definitive diagnostic approach. Virus may be isolated from herpetic lesions (skin, cornea or brain). It may also be found in throat washings, CSF and stool both during primary infection and during asymptomatic periods. Inoculation of tissue cultures is used for viral isolation. The appearance of typical cytopathic effects in cell culture in 2-3 days suggests the presence of HSV.

#### **Serology**

Serological methods are useful in the diagnosis of primary infection. Antibodies appear in 4-7 days after infection and reach a peak in 2-4 weeks. They can be measured by NT (Neutralization test), CFT

(Complement fixation test), ELISA, Radio Immuno Assay or Immuno Fluorescence

### **CONTROL:**

Transmission of HSV can be reduced by alleviating over crowding, practicing simple hygiene and education regarding the infectious stages. Sexual transmission may be significantly reduced by the use of condoms.

### **Points to remember:**

1. There are eight human herpes viruses
2. They are icosahedral double stranded DNA viruses
3. They replicate inside the nucleus and produce intranuclear inclusion bodies
4. Herpes viruses reside latently in the infected ganglia and get reactivated following different kinds of stress
5. HSV produces different kinds of clinical illness

## Chapter - 8.21

### HEPATITIS VIRUSES

#### Introduction:

The term 'viral hepatitis' is used to describe infections caused by a diverse group of viruses. They primarily infect liver. Six heterogeneous groups of viruses have been recognized, and named as Hepatitis A, B, C, D, E and G. Acute hepatitis may also occur in other viral infections, such as CMV, EB virus, HSV, and yellow fever virus. All these viruses present a similar clinical picture during the acute phase of the illness. A specific diagnosis can only be made in the laboratory. Common clinical manifestations are anorexia, nausea, vomiting, right upper quadrant pain, elevated liver enzymes and jaundice. The majority of infections are totally asymptomatic. Hepatitis virus type A and E are enterically transmitted. Hepatitis virus type B, C, D and G parenterally transmitted.

#### Hepatitis A - "Infectious Hepatitis"

This virus belongs to the family Picornaviridae. This is a small, non-enveloped icosahedral particle, 27 nm in diameter, containing a positive sense single stranded RNA genome.

#### PATHOGENESIS:

Virus enters via the feco-oral route. Replication takes place in the alimentary tract and spreads to infect the liver, where it multiplies in hepatocytes. Incubation period is 3-5 weeks (mean 28 days). Viraemia is transient. Virus is excreted in the stools for two weeks preceding the onset of symptoms, milder disease than Hepatitis B; and asymptomatic infections are very common, especially in children. Adults, especially pregnant women, may develop more severe disease. Although convalescence may be prolonged, there is no chronic form of the disease. Fulminant hepatitis is rare (0.1% of cases)

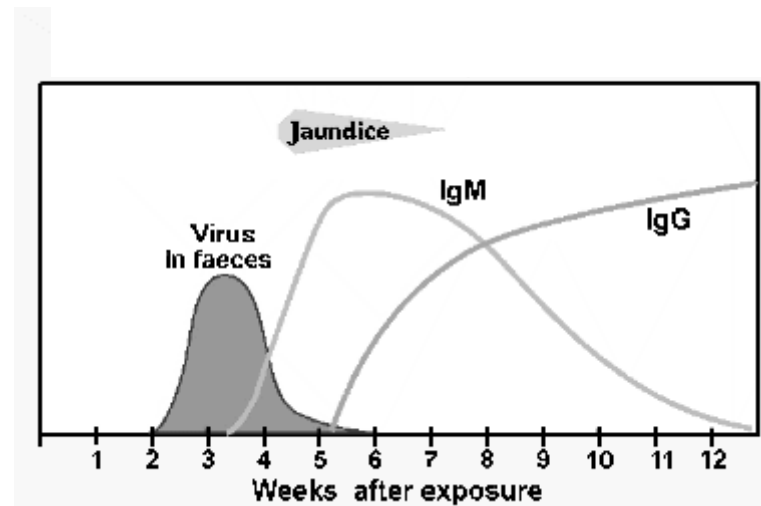


Fig. 8.21-1 Hepatitis A typical sequence of events following infection

#### MODE OF TRANSMISSION:

Large numbers of virus particles are excreted in stools before the onset of symptoms.

It is transmitted from case-to-case, via faecal-oral route. Outbreaks in creches are very common. Through contamination of food or water with sewage and infected food handlers or shell fish grown in sewage-polluted water the virus may be transmitted.

#### LABORATORY DIAGNOSIS:

Virus cannot be cultured *in vitro* from clinical material, and diagnosis is made on the presence of HAV-specific IgM in the patient's blood.

**PREVENTION:** Prevention is effected by 1) Passive immunization by the administration of normal immunoglobulin given to travelers to third world countries and household contacts of acute cases or by 2) active immunization with inactivated cell culture-derived vaccine.

#### Hepatitis E

Recently identified cause of enterically transmitted non-A, non-B hepatitis. It belongs to "Hepatitis E like virus" (earlier put in calicivirus).

It is a spherical, non enveloped, 27-34 nm particles containing a ssRNA genome.

### PATHOGENESIS:

Similar to hepatitis A; virus replicates in the gut initially, before invading the liver, and virus is shed in the stool prior to the onset of symptoms. Viraemia is transient. A large inoculum of virus is needed to establish infection. Incubation period is 30-40 days. Clinical picture presents as acute, self limiting hepatitis, no chronic carrier state exists. Predominantly affects young adults of age 15-40 years.

Complications lead to fulminant hepatitis in pregnant women. Mortality rate is high (up to 40%).

### EPIDEMIOLOGY:

Little is known yet. Large outbreaks have been described in India, Mexico and North Africa where the source of infection is usually gross faecal contamination of drinking water supplies. Case-to-case transmission to household contacts appear to be uncommon. This suggests that a large inoculum is needed to establish infection.

### LABORATORY DIAGNOSIS:

No routine laboratory tests are available as yet. Virus cannot be cultured *in vitro*.

Diagnosis is mainly done by:

1. Demonstration of Calicivirus-like particles in the stool, by electron microscopy.
2. Specific IgM in serum.
3. PCR HEV-specific sequences in stool.

### PARENTERALLY TRANSMITTED HEPATITIS - B, C, D and G

#### Hepatitis B

It belongs to the family **Hepadnaviridae**. Virion measures around 42 nm in size which contains a circular dsDNA genome. It is also known as "Dane particle."

Antigens of HBV:

**HBsAg** - surface antigen

**HBcAg** - core antigen

**HBeAg** - secreted protein

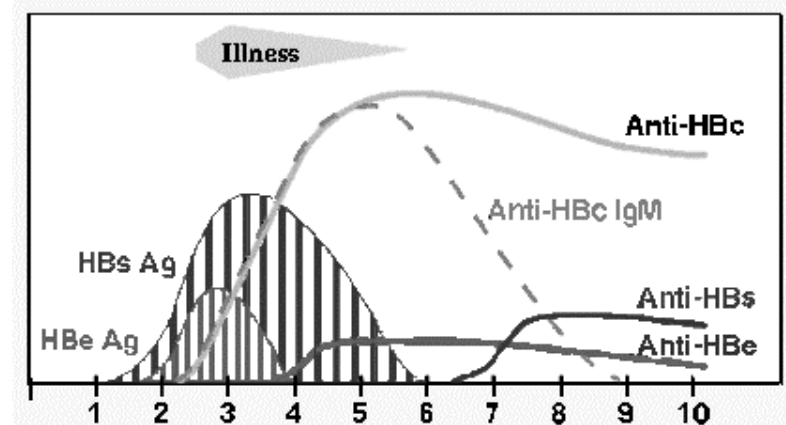


Fig. 8.21-2 Hepatitis B typical sequence of events following infection

### PATHOGENESIS:

Infection is parenterally transmitted. Incubation period ranges from 2 to 5 months. Primary virus replication takes place in the liver. Virus particles and viral surface proteins are shed in the blood stream. Prolonged viraemia is seen and the patient's blood is highly infectious. HBV causes a more severe disease than Hepatitis A. Asymptomatic infections occur frequently. 5% of infected individuals fail to eliminate the virus completely and become persistently infected. High risk group includes babies, young children, immunocompromised patients. HBV persists in the hepatocytes and on-going liver damage occurs due to the host immune response against the infected liver cells.

Two types of Chronic infection are seen:

- *Chronic Active Hepatitis* - There is aggressive destruction of liver tissue and rapid progression to cirrhosis or liver failure.



- *Chronic persistent Hepatitis* - the virus persists, but there is minimal liver damage.

Patients who become persistently infected are at risk of developing hepatocellular carcinoma (HCC). Fulminant hepatitis is rare and accounts for less than 1% of infections.

### EPIDEMIOLOGY:

World-wide there are 450 million persistent carriers of hepatitis B. Carriage rates vary markedly in different areas.

### Mode of transmission:

Hepatitis B is parenterally transmitted.

#### 1) Blood:

Through blood transfusions, serum products, sharing of needles, razors, tattooing, acupuncture, renal dialysis, organ donation.

#### 2) Sexual intercourse

3) **Horizontal transmission** in children, families, 'close personal contact'.

This is the major mode of transmission in South Africa where the majority of individuals become infected at between three and nine years of age.

Horizontal transmission also occurs in children's institutions and mental homes.

4) **Vertical transmission** - perinatal transmission from a carrier mother to her baby.

### LABORATORY DOIAGNOSIS:

Serology is based on the detection of viral antigens and antibodies, using RIA, ELISA.

### Viral antigens:

1. **Surface antigen (HBsAg)** is secreted in excess into the blood as 22 nm spheres and tubules. Its presence in serum indicates that virus replication is occurring in the liver.

2. **'e' antigen (HBeAg)** secreted protein is shed in small amounts into the blood. Its presence in serum indicates that a high level of viral replication is occurring in the liver.
3. **core antigen (HBcAg)** core protein is not found in blood

### Antibody response:

- 1) **Surface antibody** (anti-HBs) becomes detectable late in convalescence, and indicates immunity following infection. It remains detectable for life and is not found in chronic carriers.
- 2) **e antibody** (anti-HBe) becomes detectable as viral replication falls. It indicates low infectivity in a carrier.
- 3) **Core IgM** rises early in infection and indicates recent infection
- 4) **Core IgG** rises soon after IgM, and remains present for life in both chronic carriers as well as those who clear the infection. Its presence indicates exposure to HBV.

### Prevention

#### 1) Active Immunization

**Two types of vaccine are available:**

**Serum derived** - prepared from HBsAg purified from the serum of HBV carriers

**Recombinant HBsAg** - made by genetic engineering in yeasts

Both vaccines are equally safe and effective. The administration of three doses induces protective levels of antibodies in 95% of vaccine recipients. Universal immunization of infants was introduced in April 1995. Infants receive 3 doses at 6, 10 and 14 weeks of age. Vaccine should be administered to people at high risk of infection with HBV:

1. Health care workers
2. Sexual partners of chronic carriers
3. Infants of HBV carrier mothers.

## 2) Passive Antibody

Hepatitis B immune globulin should be administered to non immune individuals following single episode exposure to HBV-infected blood. For example: needle stick injuries.

## Hepatitis C

The major cause of parenterally transmitted non A non B hepatitis. It belongs to the family *Togaviridae*. It has a ssRNA genome and does not grow in cell culture, but can infect Chimpanzees.

## PATHOGENESIS

Incubation period is 6-8 weeks. It causes a milder form of acute hepatitis than does hepatitis B. But 50% individuals develop chronic infection, following exposure. Major complications are Chronic liver disease and Hepatocellular carcinoma. It is endemic in many countries and prevalent world-wide.

Transmission of HCV is by blood transfusions, blood products, organ donation, and by intravenous drug abusers.

The mechanism of community acquired infection is unclear. The other mode of transmission is through sexual intercourse.

## LABORATORY DIAGNOSIS:

- 1) **Serology:** Reliable serological tests have only recently become available. Detection of HCV-specific IgG indicates exposure, not infectivity.
- 2) PCR detects viral genome in patient's serum.

## Hepatitis D (Delta Agent)

It is a defective virus which requires Hepatitis B as a helper virus in order to replicate. Infection therefore only occurs in patients who are already infected with Hepatitis B. The virus particle 36 nm in diameter encapsulated with HBsAg, derived from HBV delta antigen is associated with virus particles ssRNA genome.

## CLINICAL FEATURES:

HDV increases the severity of liver disease in Hepatitis B carriers.

## Hepatitis G (HGV)

It belongs to the family of *Flaviviridae* and is distantly related to HCV. It was originally cloned from the serum of a surgeon with non-A, non-B, non-C hepatitis, has been called Hepatitis G virus. It was implicated as a cause of parenterally transmitted hepatitis, but is no longer believed to be a major agent of liver disease.

## Points to remember:

1. Six heterogeneous groups of viruses have been recognized, and named as Hepatitis A, B, C, D, E and G. which are implicated in viral hepatitis
2. HAV, and HEV are transmitted from case-to-case, via faecal-oral route. Hepatitis virus type B, C, D and G parenterally transmitted.
3. HAV and HBV infections can be prevented by active immunizations

## Chapter - 8.22

### HIV

#### Introduction

HIV, the etiological agent of Acquired immune deficiency syndrome (AIDS), belongs to the lentivirinae subfamily of the family Retroviridae. The subfamily lentivirinae includes the causative agents of the slow virus diseases Visna/Maedi in sheep and infectious anemias in goats and horses. Besides HIV, the related animal Immunodeficiency viruses such as SIV (Simian Immunodeficiency virus), FTLV are also assigned to this subfamily.

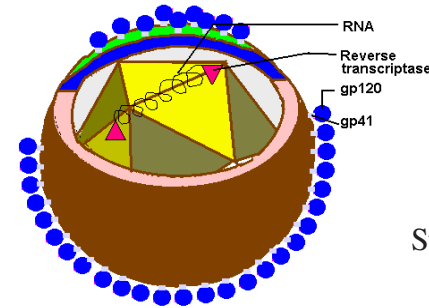
#### 8.25-1 Structure

HIV is a spherical enveloped virus measuring from 90-120nm in size. The nucleocapsid has an outer icosahedral shell and an inner cone shaped core. The core encloses two molecules of single-stranded RNAs and the enzyme reverse transcriptase, an RNA-dependant DNA polymerase.

#### Replication

HIV, in general Retroviruses differ from other RNA viruses in that they replicate and produce viral RNA from a DNA copy of the Virion RNA. HIV attaches to the CD4 receptor of T-helper lymphocytes by means of its external envelope glycoprotein gp120. Attachment is followed by entry of the virus by fusion of the two membranes, mediated by gp41. Once the RNA is released, the reverse transcriptase acts to form the double stranded DNA copy (pro virus). The viral DNA is transcribed into viral m-RNA and RNA using host RNA polymerase. Virions are assembled at the cell membrane where envelope and core proteins are located. When the naked virus buds out through the host cell surface membrane, it acquires a lipoprotein envelope, which consists of lipid derived from host cell membrane and glycoprotein which are virus coded. The major virus coded envelope proteins are surface

glycoprotein spike [gp120] and the transmembrane pedicle glycoprotein [gp41]. This type of growth cycle is termed as productive growth cycle. In the productive cycle the host cell is destroyed. Most often the double stranded DNA (provirus) is integrated into the host cell chromosome and remains latent. Once inserted into the host DNA, infection with HIV is permanent.



**Fig. 8.22-1**  
Structure of HIV

#### Pathogenesis

The typical course of HIV infection spans about ten years. There are various stages of HIV infection including primary infection, dissemination of virus to lymphoid organs, clinical latency, induction of HIV expression, clinical disease and death.

The duration between primary infection and progression to clinical disease averages about 10 years. Death usually occurs within 2-5 years after the onset of clinical symptoms.

#### Clinical manifestations

According to the Center for Disease Control, (USA) the HIV infection and its sequelae are classified into four groups.

Group I – Acute HIV infection/seroconversion illness.

Group II – Clinical latency/asymptomatic.

Group III – Persistent generalized lymphadenopathy.

Group IV – A – Constitutional disease ; B – Neurologic disease  
C – Secondary infectious disease ; D – Secondary cancers  
E – Other conditions.

**Acute HIV infection:**

This is otherwise called as seroconversion illness. The patient with HIV infection for 2-6 weeks experience symptoms resembling glandular fever and adenopathy. It is recognized in 5-10% of patients. Recovery occurs within weeks. Initially HIV antibodies are negative and rise during the course of illness.

**Clinical latency:**

All HIV infected individuals pass through a phase of asymptomatic infection otherwise called clinical latency, which extends up to several years. Patients are infectious and tests for HIV antibodies are positive. Viral multiplication takes place throughout the period of clinical latency. The CD4 T cell count decreases steadily and when the count falls to 200 or less full blown AIDS develops.

**Persistent generalized lymphadenopathy:**

The persistence of enlarged lymph nodes in two or more non contiguous extra inguinal sites for more than three months, in the absence of any other causes of adenopathy such as lymphomata is called as persistent generalized lymphadenopathy.

**Constitutional diseases:**

Patients in this group suffer from a variety of constitutional symptoms fever, persistent diarrhea and marked weight loss or with minor opportunistic infections. The patients are severely ill and present with generalized lymphadenopathy and splenomegaly. These symptoms are called as AIDS related complex (ARC) and the patients may progress to AIDS.

**Neurologic disease:**

About 90% of HIV patients have neurologic diseases such as toxoplasmosis, cryptococcosis and lymphoma of the central nervous system. Distinct neurological syndromes such as subacute encephalitis, vacuolar myelopathy, aseptic meningitis and dementia complex frequently occurs in patients with AIDS.

**Secondary infectious diseases:**

The major cause of death among AIDS patients is secondary infectious diseases caused by opportunistic pathogens. As a result of

the breakdown of the immune defense mechanisms these opportunistic infections progress rapidly leading to death.

The common bacterial opportunistic pathogens are:

Bacterial infections: Tuberculosis with *M.tuberculosis* and *M.avium-intracellulare.*, Salmonellosis with recurrent septicaemia, Streptococcal infections, Legionellosis.

Fungal infections: Candidiasis, Cryptococcosis, *Pneumocystis carinii* pneumonia, Aspergillosis and Histoplasmosis.

Parasitic infections: Cryptosporidiasis, Isosporiasis and Toxoplasmosis of brain.

Viral infections: CMV retinitis, HSV infection in bronchi lungs and oesophagus, Kaposi sarcoma due to HHV8.

Secondary cancers: Most common types of AIDS associated cancer are non-Hodgkins lymphoma and Kaposi's sarcoma. Anogenital cancers, Hodgkin's lymphoma, Burkitt's lymphoma are the other cancer types seen in AIDS patients.

**Paediatrics AIDS:**

Paediatrics AIDS is acquired from HIV infected mothers. The infected children develop severe humoral immunodeficiency and suffer from recurrent bacterial infection, chronic diarrhea, tuberculosis, lymphoid interstitial pneumonia and pulmonary lymphoid hyperplasia. However the children may also suffer from infections seen in older patients.

**Immunity:**

HIV infection and AIDS are characterized by profound immunosuppression. Antibodies to the envelope glycoproteins and core proteins(p24) develop within two months of primary infection. When the clinical signs and symptoms develop the anti p24 antibody level declines. In asymptomatic individuals high titres of anti-p24 antibody is present. During the asymptomatic period the number of CD4 T-cells decreases leading to the impairment of resistance to infection. The number of CD8 T-cells, increases as the disease develops. The destruction of CD4 T-cells occurs by replication of HIV, lysis of infected cells by cytotoxic T-cells, NK Cells & ADCC [Antibody dependent Cell-mediated cytotoxicity.] As a result of the decrease in CD4 T-cells and increase in CD8 T-cells, immunological changes like decrease in func-

tion of lymphocytes, macrophages and natural killer cells, decrease in the production of IL-2, interferon- $\alpha$  and other lymphokines, polyclonal activation of B-cells are observed. As the disease progresses, the full blown AIDS develops. The total lymphocyte count decreases to 2000 cu.mm, CD4 T-cell count decreases to 200 and the CD4:CD8 T-cells ratio is reversed. In majority of individuals with AIDS, loss of cutaneous hypersensitivity is seen.

**Laboratory Diagnosis:** Diagnosis of HIV infection can be done by virus isolation., antigen detection, and performing PCR. [Polymerase Chain Reaction), Serological test & Test for immunodeficiency are done.

**Modes of transmission:** HIV is transmitted by the following methods. Sexual contact with infected persons, by blood and blood products, sharing of needles in drug addicts, needle stick injury in health care workers and from infected mother to baby.

**Prevention:**

1. The best method of checking sexual transmission of HIV is health education regarding the danger of promiscuity and other high risk activities.
2. Persons indulging in high risk sexual practices should be counseled regarding 'safer sex'. The use of condoms offers considerable though not complete protection. The risk of HIV transmission increases with multiple partners.
3. Screening of blood donors is now mandatory. To eliminate complete danger in transfusion of blood and blood products p24 antigen screening is done.
4. Any person indulging in high risk practices should be restricted from donating blood, semen, cornea, bone marrow and other organs.
5. The use of disposable syringes, needles and other equipments should be obligatory.
6. Medical and nursing personal should take adequate precaution against the danger of 'needle-stick' injury.
7. To prevent vertical transmission from mother to baby, infected women should be advised against pregnancy. HIV is rarely transmitted through breast milk.

8. Normal social and domestic contact like shaking hands, hugging, putting cheeks together or dry kissing are safe. There is no confirmed evidence of transmission through saliva, mosquitoes, bed bugs, other blood sucking insects, air, food, water or fomites.

**Prophylaxis:**

No specific vaccine is available. The high mutability, diverse antigenic types and subtypes, long latency and persistence in infected cells as 'Provirus' pose serious problems in the development of vaccines.

**Treatment:**

Approaches to the treatment of AIDS include, the treatment and prophylaxis of infections and tumors. Prompt diagnosis and appropriate treatment of opportunistic infections and tumors in the early stage of AIDS helps the patients to resume normal life between episodes of illness. General management of the patient requires the understanding and cooperation of the health staff and relatives at home. Immuno restorative therapy such as administration of interleukin-2, thymic factors, leucocyte transfusion and bone marrow transplantation are not very helpful. Specific treatment with anti HIV drugs like Zidovudine (Azidothymidine, AZT), Didanosine, Zalcitabine, Lamivudine, Saquinavir, Ritonavir, Indinavir are used as monotherapy or in various combinations.

**Points to remember:**

1. HIV, the etiological agent of Acquired immune deficiency syndrome (AIDS), belongs to the lentivirinae subfamily of the family Retroviridae.
2. There are various stages of HIV infection including primary infection, dissemination of virus to lymphoid organs, clinical latency, induction of HIV expression, clinical disease and death.
3. HIV is transmitted by the following methods. Sexual contact with infected persons, by blood and blood products, sharing of needles in drug addicts, needle stick injury in health care workers and from infected mother to baby.
4. It is essential to follow the preventive measures mentioned.

## Chapter - 8.23

### BRUCELLOSIS

The genus *Brucella* consists of a group of Gram negative bacilli that are pathogens of animals, mainly domestic animals like goats, cattle, sheep and pigs. Infection in pregnant animals leads to abortion. Involvement of mammary glands leads to the excretion of brucella organism in milk for months or even years. Human beings get the infection from milk or milk products.

Brucellosis is a typical zoonotic disease and it spreads from animal to man but it does not spread from man to man. Fever, chills, sweating, malaise, weakness and various types of pains occur in man. Acute brucellosis causes intermittent or undulations of temperatures. So this fever is also known as undulant fever. But these types of symptoms do not occur in all the brucella infections and can be seen only in some.

Brucellae are Gram negative bacilli and are so short that they appear like cocci [coccobacilli]. They are non-motile, non-capsulated and non-sporing. They are aerobes and grow well in the presence of 5-10% carbon-di-oxide. They survive in the soil and manure for a long time. They have been isolated from butter, cheese and ice cream prepared from infected milk. They survive in meat, pork and may remain viable after refrigeration for several weeks. They are killed in 10 minutes by temperature of 60°C and infected milk is safe for use after Pasteurization.

There are three main species of *Brucella* and they differ in their animal host, some cultural and biological characters and in the amount of two antigens that are common for the three. They are *Brucella melitensis*, which infects goat and sheep, *B. abortus* which infects cattle and *B. suis* that infects pigs.

### Pathogenesis

The incubation period may last about 10-30 days and the infection may persist without showing any symptoms. If there is no fluctuation in the temperature, diagnosis may be difficult. All the species are pathogenic to man. The organism enters the body through skin abrasions, the mucus membrane of the alimentary and respiratory tracts. It reaches blood stream through the lymphatics. The infection may be there without producing any symptoms or it may cause classical undulant fever. The organism produces granulomatous lesions in the reticuloendothelial system, liver, spleen and bone. Complications may involve any part of the body. The organisms may survive inside the granulomata and cause relapses or hypersensitivity reaction.

### Clinical manifestations

Symptoms are associated with continued illness and vague symptoms of malaise, low grade fever, insomnia, irritability and joint pain with swelling. After such chronic brucellosis acute attack may be seen after many years.

### Laboratory diagnosis

Blood is collected as specimen and is cultured in glucose serum broth, in duplicates. Subcultures on to solid media are made and characteristic colonies are looked for. The blood cultures are kept at least for 6 weeks before they are discarded as negative.

### Serology

Antibodies may be detected 7-10 days after onset of clinical infection. In the acute stage agglutinating antibodies give high titre and begin to fall. Both agglutinating and complement fixing antibodies are found in the acute stage. Agglutinating antibodies are IgM and the complement fixing antibodies are IgG. When the disease becomes chronic, the IgM antibodies decrease and the agglutination titre may fall low or may show nil even when the patient is ill. But IgG antibodies are present during infection and they can be detected by complement fixation test. One more method to detect the non agglutinating antibodies

is the use of anti-human globulin serum. This helps in agglutinating Brucella suspension which is already sensitized by the non agglutinating antibodies in the patient serum.

### **Epidemiology**

*B. melitensis* was the first organism to be studied. The organism was first isolated from the spleen of fatal cases by an Army doctor, David Bruce in 1886. He was serving with the British Army on the island of Malta. So this fever was called Mediterranean or Malta fever. He described it as a coccus. During that time more Army and Navy personnel were affected. The name Brucella was given in honor of Bruce, to establish it as the cause of Mediterranean fever by transmitting the infection to monkeys. After 20 years Zammit a bacteriologist showed that the organism Brucella was transmitted to man through goat's milk.

In Great Britain *B. abortus* is the only species which causes human brucellosis. In spite of wide spread vaccination of cattle *B. abortus* infection remains endemic among cattle and milk is the major source of infection. A milk ring test is the screening test to detect the presence of agglutinating antibody in dairy cattle. *B. suis* causes infection when people eat infected pig meat or have contact with infected pigs. Horses are susceptible to all the three species of Brucella

### **Prevention and control**

#### **Vaccination**

Cattle should be vaccinated between 6 and 8 months of age to avoid abortion due to invasion of the organism to the uterus. A live attenuated vaccine, similar to one used to immunize cattle, has been used to immunize the persons who are at risk [veterinarians and farmers]. Otherwise this vaccine is not used for normal persons because of undesirable side effects.

#### **Pasteurization**

Pasteurization eliminates Brucella organisms from infected milk and milk products.

### **Points to remember**

1. Brucella causes a zoonotic disease called brucellosis. Disease spreads from animal to man and does not spread from man to man.
2. Acute brucellosis causes intermittent or undulations of temperatures. So this is called undulant fever.
3. They are coccobacilli and grow well in the presence of 5-10% carbon-di-oxide. There are three important species and they are *Brucella melitensis*, *B. abortus* and *B. suis*.
4. The organisms produce granulomatous lesions in the reticuloendothelial system, liver, spleen and bone.
5. They cause acute infections and later the infection becomes chronic.
6. Blood cultures are done. IgM antibodies appear in the acute infection and disappear completely. IgG antibodies are seen in chronic infection.
7. Animals are vaccinated to avoid abortion. Milk is pasteurized to eliminate the spread of brucellosis to man.

## Chapter - 8.24

# LYME DISEASE

### Introduction

Lyme disease is an infection caused by a spirochete called *Borrelia burgdorferi*. Initially many cases were identified in a town Lyme in Connecticut, USA and hence the illness is named as Lyme disease. It is an extremely complex illness, affecting skin, joints, heart, nervous system and others. Distinctive skin lesions called erythema migrans along with headache, stiff neck, myalgia, arthralgia, fatigue, and possible swelling of the lymph node usually recognize the disease, Not all the symptoms are present in every case. Untreated persons may develop meningoencephalitis, myocarditis, or even arthritis particularly of knees.

### Definition:

Lyme borreliosis is a tick transmitted spirochetal illness characterized by expanding skin lesions, Erythema migrans (EM) accompanied by flu like or meningitis like symptoms (stage 1), followed by frank meningitis, cranial or peripheral neuritis, carditis or migratory musculoskeletal pains (stage2), leading on to chronic arthritis or chronic neurologic or skin abnormalities (stage3).

### Etiology

Lyme disease is caused by the spirochete, *Borrelia burgdorferi*. This spiral bacterium is named after the discoverer, Willy Burgdorfer. This spirochete is 11-39 micrometers long and 0.3-0.4 micrometer wide. The spirochete is highly flexible, has 7-11 flagella and moves by rotation and twisting. It can readily be stained by simple stains and Giemsa stain. They survive in liquid environment such as mud water or blood. It grows in BSK (Barber, Stonner and Kelly) medium. The organism possesses 3-7 plasmids, one of which codes for two major proteins 31kDa OSP A protein and 34 kDa B protein. These proteins appear to undergo antigenic variation during the course of infection.

### Epidemiology

**Distribution:** Lyme disease has worldwide distribution and is present in USA, Eurasia, Japan, Australia etc.

**Vectors :** Ixodid ticks act as vectors. These include, *I. dammini*, *I. pacificus*, *I. ricinus*, *I. persulcatus*.

### Reservoir animals

**Small mammals:** Wood mouse, yellow necked field mouse, black striped mouse, bank vole, edible dormouse, meadow vole, water shrew, pigmy shrew and common shrew.

**Medium size mammals:** Hedge hog, varying hare, brown hare, brown rat, black rat, grey squirrel, red squirrel.

**Birds:** Tree pipit, robin, thrush nightingale, blue throat, great tit, pheasant, redstart, black cap, white throat, wren, black bird, song thrush.

### Pathogenesis

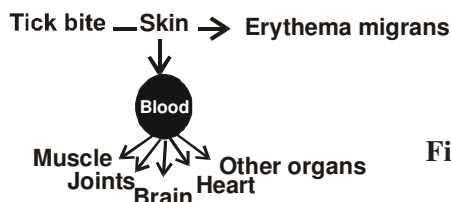


Fig. 8.24-1 Pathogenesis

After injected into the skin, the spirochetes may migrate outward in the skin producing Erythema migrans. It may also spread hematogenously to other organs. It has been isolated from skin, blood, CSF, synovial fluid, and also has been seen in affected tissues.

### Clinical manifestations:

Lyme disease occurs in stages with remissions and exacerbation and different clinical manifestations at different stages.

### STAGE 1

#### ERYTHEMA MIGRANS (EM)

After an incubation period of 3-32 days, EM occurs at the site of the tick bite. It begins as a red macule or papule that expands to



form a large annular lesion. Usually it has a bright red outer border and partial central clearing. As the Ixodid ticks are small, many patients do not remember the preceding bite. Lesions can be located anywhere. Generally they are commonly seen in the thigh, groin, and axilla. Lesion is warm but not often painful. Spirochetes may be present in the local site or they spread hematogenously through out the body. EM patients may develop secondary annular skin lesions. Dermal symptoms may accompany others like severe headache, mild neck stiffness, fever chills, migratory musculo skeletal pain arthralgia malaise and fatigue. Less common manifestations seen are generalized lymphadenopathy, splenomegaly hepatitis, sore throat nonproductive cough conjunctivitis, and testicular swelling. Fatigue and lethargy last for several months. Others may disappear within several weeks.

## STAGE 2

### NEUROLOGICAL SYMPTOMS

Symptoms suggestive of meningeal irritation may occur in early Lyme disease when EM is present. After several weeks to months about 15 percent of the patients develop frank neurological abnormalities. These include meningitis, subtle encephalitic signs, cranial neuritis, bilateral facial palsy, chorea or myelitis alone or in various combinations. CSF shows lymphocytic pleocytosis(100 cells/μl), elevated proteins, normal or slightly low glucose. These symptoms may resolve within months. Chronic symptoms may occur later.

### CARDIAC INVOLVEMENT

Within several weeks after the onset of illness, about 8% of patients develop cardiac symptoms. Most common abnormality was atrioventricular block. Rare cardiac symptoms are cardiomegaly, pancarditis. Cardiac symptoms may last for few weeks but may recur. Musculoskeletal symptoms may also be noticed commonly during this stage. Migratory pain in joints, tendons, bursae, muscle or bone are the symptoms present.

## STAGE 3:

### ARTHRITIS:

Within weeks to 2 years after the onset of infection 80% of

untreated patients develop joint symptoms. They include subjective joint pains, intermittent attack of arthritis to chronic erosive synovitis. The typical pattern is oligoarticular arthritis in large joints such as knee joints. Symptoms last for weeks to months. Small joints and periarticular sites may also be involved. Recurrence may last for many years. Chronic arthritis may lead to erosion of cartilage and bone.

## LABORATORY DIAGNOSIS

**Specimens:** Skin biopsy, slit smear, intradermal aspirates, Blood, and CSF are collected for examination

**Direct examinations :** Dark field microscopy, and Giemsa staining are done to demonstrate the organisms.

**Polymerase chain reaction(PCR) :** Blood, Plasma, Buffy coat, CSF, urine and Ticks are collected. From these specimens DNA is extracted and using Borrelia specific primers, the DNA is amplified and detected.

**Culture :** Specimens are inoculated into BSK medium, and the growth of the organisms are looked for.

**Serology :** Indirect immunofluorescence test and **ELISA** tests are done : Four fold rise in titre of specific IgM antibodies are demonstrated. Western blot test is done to confirm the diagnosis.

**Treatment:** Tetracyclines, doxy cycline, minocycline are used. Penicillins: Amoxycillin with probenecid are also effective.

**Prophylaxis:** Avoid Tick Bite.

### Points to remember

1. Lyme borreliosis is zoonotic disease. It is transmitted through the bite of Ixodid ticks.
2. Reservoir animals are small mammals and birds
3. Skin lesions, cardiac involvement, and CNS infections are common.
4. If not treated may lead to chronic arthritis.
5. Dark field microscopy, and Giemsa staining are done to demonstrate the organisms. Also, diagnosis is made by demonstrating specific antibodies.

## Section V

# IMMUNOLOGY

## Chapter 9.1

### ORGANS AND CELLS OF IMMUNE SYSTEM DEVELOPMENT OF CELLS IN THYMUS

In the previous class we have seen the structure and development of immune system. We have studied the structure of thymus gland and its functions. Thymus plays an important role in T cell development.

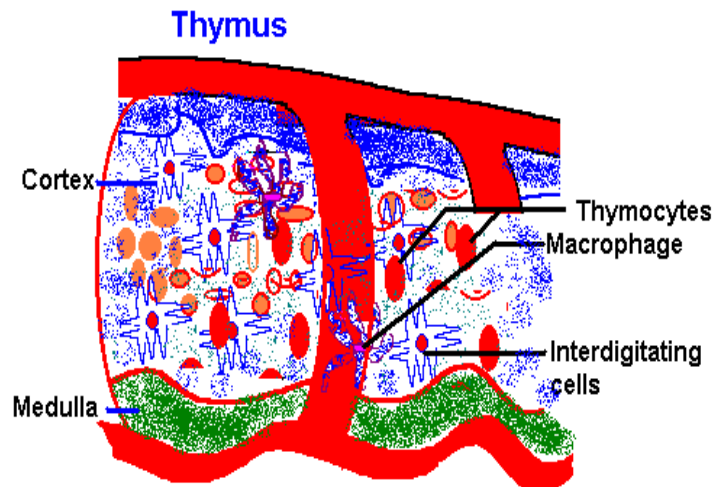


Fig. 9.1-1 Thymus

Thymus in mammals is a bilobed organ, located in the thoracic cavity overlying the heart and major blood vessels. Each lobe is organized into lobules separated from each other by a connective tissue called trabeculae within each lobule the lymphoid cells (thymocytes) are arranged into cortex and medulla.

The cortex contains relatively immature thymocytes. In medulla more mature thymocytes are seen. Immature prethymic cells from bone marrow come to cortex where they mature. Three types of epithelial cells are present in the thymic lobules. They are

1. Epithelial nurse cells which are in the outer cortex
2. The cortical epithelial cells which form an epithelial network and
3. The medullary epithelial cells which are organized into clusters.

In addition to these cells interdigitating dendritic cells (IDC) and macrophages both derived from bone marrow are also seen in thymus. These two cells are found in cortico-medullary junction. Epithelial cells, IDC and macrophages possess major histocompatibility MHC molecule which are crucial for T cell development and selection.

### Development of T cells in thymus

In the embryonic life the thymus develops from the third pharyngeal pouch. Initial epithelial rudiment is seeded with blood borne stem cells. The ectoderm of the third branchial cleft forms the epithelium of the thymic cortex. The endoderm of the third pharyngeal pouch differentiates into epithelium of thymic medulla.

Stem cells migrate into the thymus due to chemotactic signals emitted from rudiment,  $\beta 2$  microglobulin and components of MHC Class I molecule. The prethymic bone marrow derived stem cells that enter the thymic rudiment is a multipotent cell. The nurse cells present in the cortex support the proliferation of stem cells arriving from the bone marrow. These stem cells develop into large, actively proliferating, self renewing lymphoblasts which generate the thymocyte population. Cortical thymocytes are less mature than medullary thymocytes. The cortical cells migrate to and mature in the medulla. The most mature T cells leave the thymus via post capillary venules located at the cortico-medullary junction.

The T cells change their phenotype during maturation. Differentiation markers of functional significance is either acquired or lost during the progression from stem cells to T cells.

During T cell maturation, sequential changes occur in the membrane antigens. In the first stage, cells express  $CD_4^-$  and  $CD_8^-$  phenotype. In this stage cells are capable of giving rise to other lineages. In the second stage cells express  $CD_4^+$  and  $CD_8^+$  phenotype. In the third stage cells show major phenotypic changes. They become either  $CD_4$  T cells or  $CD_8$  T cells. Immature cell markers are absent as they become mature T cells. During this maturation in thymus, T cell receptor diversity and positive and negative selection occur.

**Points to remember:**

1. Thymus plays an important role in T cell development. It is organised into various sections containing different types of cells.

## Chapter - 9.2

### ANTIGEN AND ANTIGEN PRESENTATION

#### Definition:

Antigen is any substance that can bind to specific antibody molecule and specific receptors on lymphocytes.

Antigen can be either complete antigen/ Immunogen which can induce specific immune responses and react with the products of these responses or incomplete antigen/hapten. This is a chemically defined substance of low molecular weight that can not induce an adaptive immune response by itself

#### Requirements for immunogenicity: (properties)

Immunogenicity is not an inherent property of a molecule. It depends on various factors:

##### 1. Foreignness

Antigen molecule must be foreign to the host. For example when rabbit protein is injected in to rabbit no antibody response occurs. But when human protein is injected into rabbit antibody response is induced. Foreignness depends also on the presence in a molecule of chemical grouping entirely unfamiliar to an organism

##### 2. Size and shape

Molecular shape does not seem to influence immunogenicity but molecular size affects immunogenicity. Smaller the molecular size it is less immunogenic. Insulin MW 6000 is a poor immunogen. Higher the molecular weight it is a powerful immunogen. For example flagella is more immunogenic than polymerized flagellin which in turn more immunogenic than monomer of flagellin

##### 3. Complexity and composition

Synthetic polypeptides are generally used to study the effect of

complexity and composition. Increasing complexity contributes to molecule's immunogenicity

#### 4. Recognition by two lymphocyte types

1. T. independent antigens  
Certain T cell independent antigens require only stimulation of specific B cells to produce antibodies  
Ex: Staphylococcal enterotoxins,
2. T dependent antigens  
Many antigens require recognition by both B and T cells  
Ex: Sheep RBC in mice
3. A molecule's immunogenicity also depends on the Species.  
Example: Dextran is immunogenic in man and mice but not in rabbits and guinea pigs.

#### 5. Immunogenicity also depends on the dose and route of administration

Very small dose may not induce immune response but may induce tolerance. Very high dose may induce paralysis. Optimum dose induces good response. Route of injection influences immune response. In intra venous injection central stimulation occurs and good antibody response is induced. In intradermal administration local lymph node stimulation occurs leading to CMI response

#### 6. Intervals between injections influence immune response

Antigen must be administered with intervals

#### 7. Uses of adjuvants potentiate immune response

##### Epitope

Epitopes are the parts of an antigen which contact the antigen-binding sites of an antibody or the T cell receptor. It is an antigenic determining site of the antigen molecule.

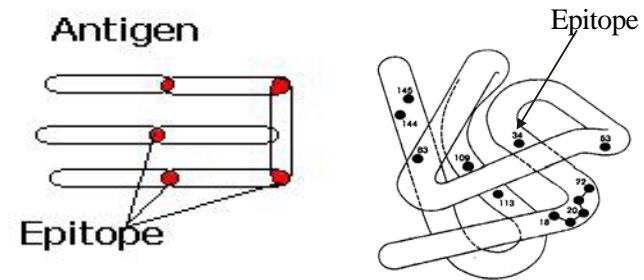


Fig.9.2-1 Epitopes present on the antigen

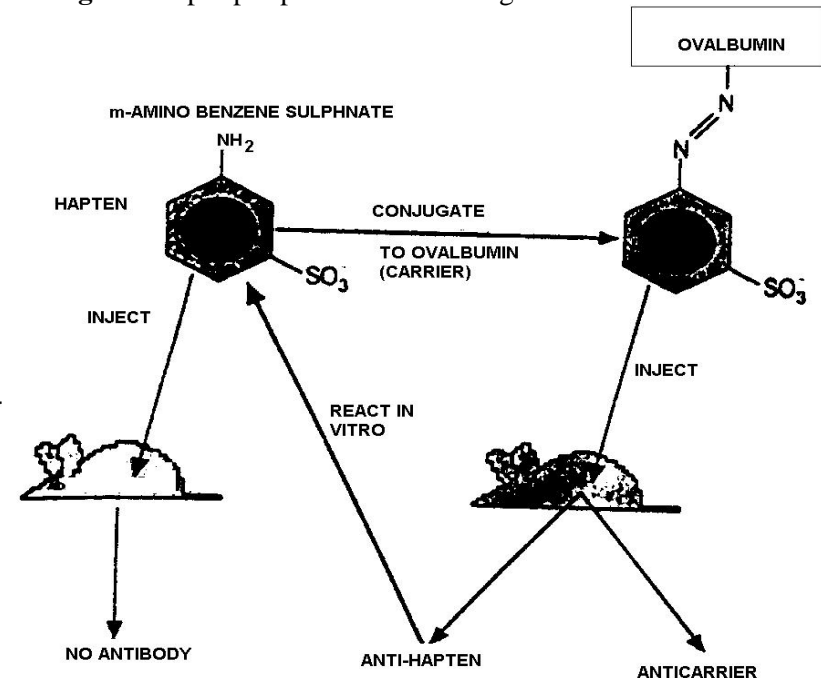


Fig.9.2-2 Mechanism of Haptens

##### HAPTENS

These are substances of low molecular weight that can not induce a specific immune response by itself. But are capable of reacting with preformed antibodies and pre induced CMI.

## CARRIER

A molecule which when conjugated to a non immunogenic molecule makes the latter immunogenic by providing epitopes (for helper T cells ) which the hapten lacks phagocytic or nonphagocytic cells which possess class I or class II MHC molecules on their surfaces.

### Antigen presenting cells

CELLS	PHAGO CYTOSIS	TYPE	LOCA-TION	CLASS II EXPRES-SION
(Monocyte / Macrophage lineage)	+	Monocytes Macrophages Marginal zone macrophages Kupffer cells microglia	Blood Tissue Spleen and lymph node Liver Brain	(+) to +++ inducible
Non-phagocytic Constitutive antigen-presenting cells	--	Langerhan's cells Interdigitating dendritic cells	Skin Lymphoid tissue	++ constitutive
		Follicular dendritic cells	Lymphoid tissue	--
Lymphocytes	--	B cells and T cells sites of immune reactions	Lymphoid tissues and at sites of Immune reactions	--To ++ inducible
Facultative antigen presenting cells	+	astrocytes	Brain	inducible
		Follicular cells endothelium	thyroid Vascular & lymphoid	Inducible
		Fibroblast	Connective	- To ++

Macrophages which are phagocytic cells that possess class II MHC molecules are the classical antigen presenting cells. Depending

on their location they have different names. (Table 9.1). Langerhan's cells, Interdigitating dendritic cells and follicular dendritic cells are some of the nonphagocytic cells that act as antigen presenting cells

## Development of APC

Precursor for the APC is the stem cells from bone marrow. Precursor gives rise to monocyte in blood. Monocytes in tissues form macrophages. Stem cells also give rise to dendritic cells found in tissue. Dendritic cells develop into Langerhan' cells in the tissues. Langerhan' cells pick up antigen, and move from the tissue to the lymph nodes. From the pool of recirculating T cells, they select and stimulate specific T cells.

## Development of antigen presenting cells

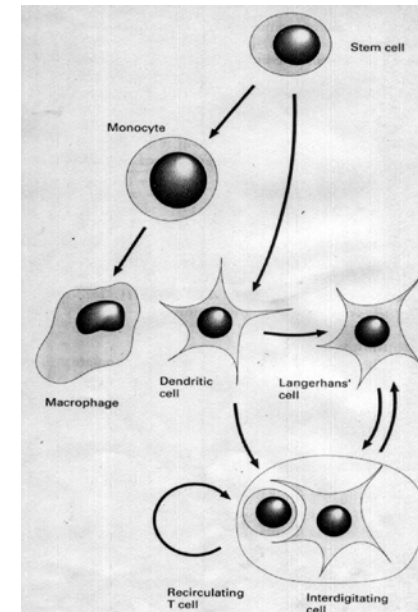
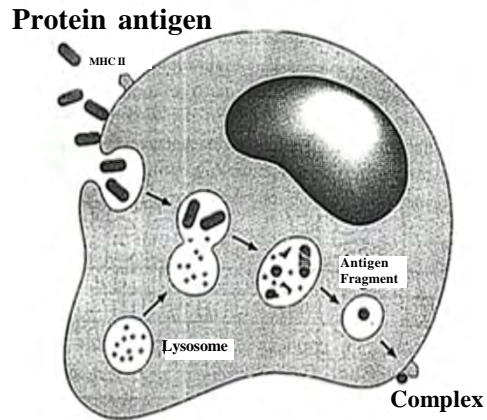


Fig.9.2-1 Development of antigen presenting cells

## Antigen processing (general view)

Antigen is attracted to the cells by chemotaxis and is attached to cell surface. Then it is internalized by phagocytosis. The antigen is

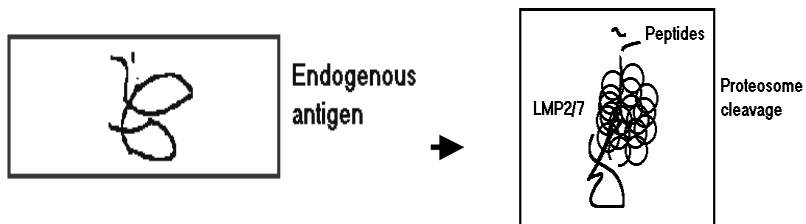
broken into small fragments. Antigen fragment is bound with MHC I or II molecule and transported to membrane.



**Fig.9.2-2** Processing of endogenous antigens

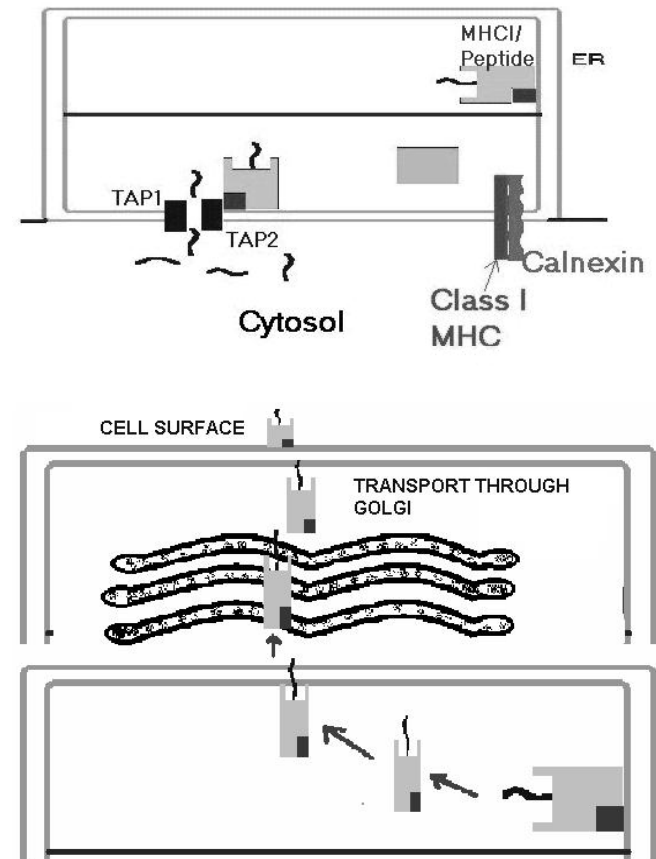
### Processing of endogenous antigens

Endogenous antigens are produced within the cell as in viral infection or the ones which are generated as a result of altered self antigens.



**Fig.9.2-3** Cleavage of endogenous antigen

These antigens are cleaved in proteasomes. Fragments are carried by protein 2/7. Delivered to TAP1 and TAP2 (transport associated proteins). Peptide binds to MHC class I molecule with  $\beta 2$  microglobulin.



**Fig.9.2-4** Peptide /MHC complex with TAP pass through Golgi system. They appear on the surface of cells to present the antigen to T cells.

### Exogenous antigen processing

- I. Class II MHC molecules are assembled from  $\alpha$  and  $\beta$  chains in the endoplasmic reticulum (ER) in association with invariant chain. The invariant chain ensures correct folding of the nascent class II molecules and inhibits premature binding of peptides in the ER.

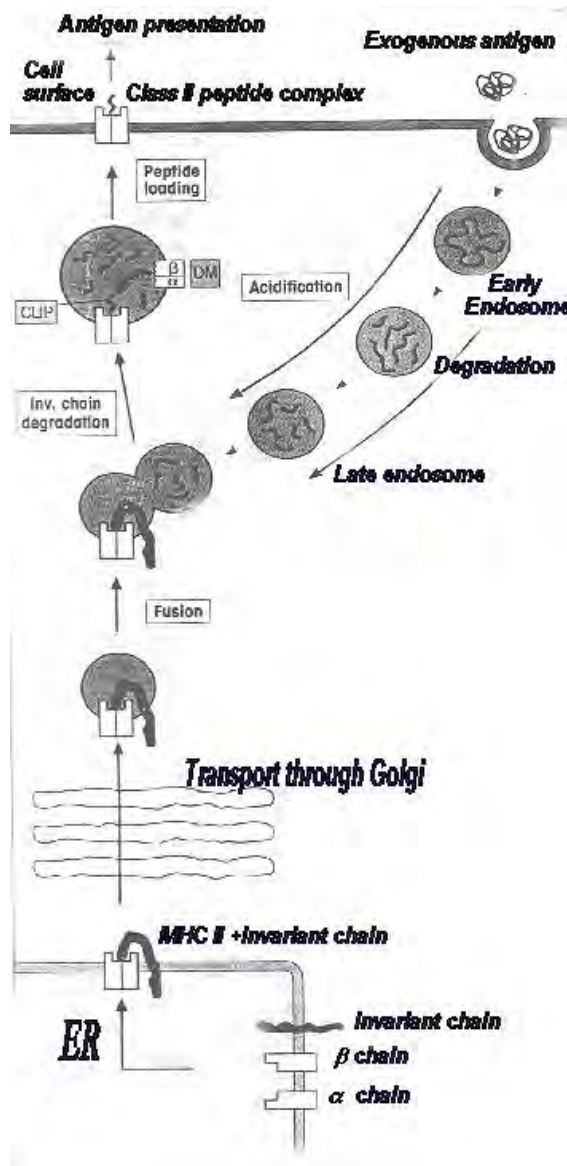


Fig.9.2-5 Overall view of exogenous antigen presentation

ER before class II reaches the endocyte compartment containing antigen. Its combination with class II allows transport to the Golgi and helps transport through Golgi.

- II. Exogenous antigen ( any infectious agent ) is phagocytosed with early endosome formation and then degradation of antigen occurs. Late endosomal vesicle is formed.
- III Late endosome fuses with class II MHC having a invariant chain. It contains partly degraded proteins from exogenous source and after the fusion, degradation of invariant chain occurs. The peptide is now found in the groove of MHC II. Now the complexes are transported to the membrane for presentation to the T cells.

**Points to remember**

1. Antigen is any substance that can bind to specific antibody molecule and specific receptors on lymphocytes.
2. Immunogenicity is not an inherent property of a molecule. It depends on various factors:
3. There are phagocytic and nonphagocytic antigen presenting cells
4. Endogenous antigens are processed and presented to T cells via MHC I molecules
5. Exogenous antigens are processed and presented to T cells via MHC II molecules



## Chapter - 9.3

# STRUCTURE AND CHARACTERISTICS OF ANTIBODIES

### Introduction:

In XI standard you have already studied the structure and functions of antibodies. In this class you will be studying little more about antibodies.

### Definition of antibodies:

Antibodies are glycoprotein molecules which are produced in response to an antigen, and react specifically with it in an observable manner.

Antibody is also known as immunoglobulins.

### Immunoglobulin classes

In man 5 major classes of Immunoglobulins are described. They are (1) Ig G which is the major serum component. (2) Ig M: It is a macroglobulin appears first after an antigenic stimulus. (3). Ig A which is present predominantly in secretions. (4) Ig D which is an important cell membrane receptor form. (5) Ig E is an immunoglobulin that is raised during allergic responses.

### Structure of antibodies

The general formula for antibody is  $(H_2 L_2)_n$ . The immunoglobulins are made up of 2 heavy chains and 2 light chains. These are held together by covalent bonds. These bonds are interchain disulphide bridges. Each chain is made of a number of loops. These loops are known as domains. Each domain is formed by intrachain disulphide bonds. There are 2 loop sections per L chain and 4 loop sections per H chain. There are two terminals in each chain. One is called C terminus and the other is called N terminus.

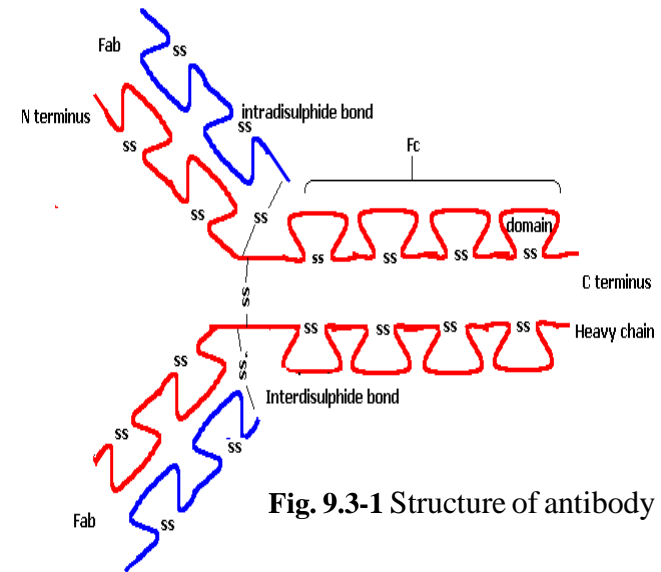


Fig. 9.3-1 Structure of antibody

### Light chain

C terminus contains the constant region.

N terminus contains the variable region.

L chain is named as Kappa ( $\kappa$ ) and lambda ( $\lambda$ ).

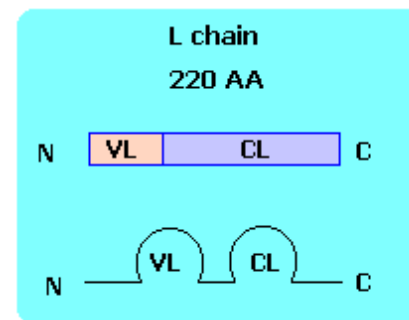


Fig. 9.3-2 Light Chain

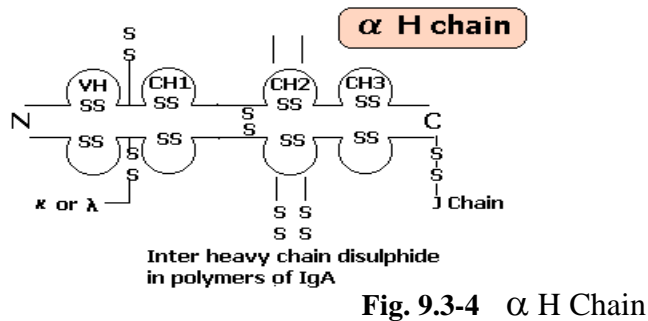
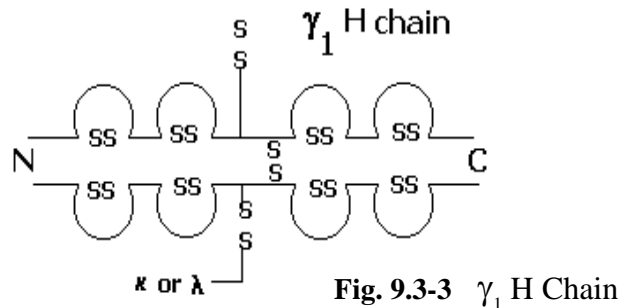
It contains two domains, domain at N terminus is variable domain of light chain and is called VL and domain at C terminus is constant domain called CL.

## Types of heavy chain

There are 5 different types of H chains. Based on the type of H chain the class of antibody is determined

They are:

- $\gamma$  Gamma - Ig G
- $\alpha$  Alpha - Ig A
- $\mu$  Mu - IgM
- $\xi$  Epsilon - Ig E
- $\delta$  Delta - IgD

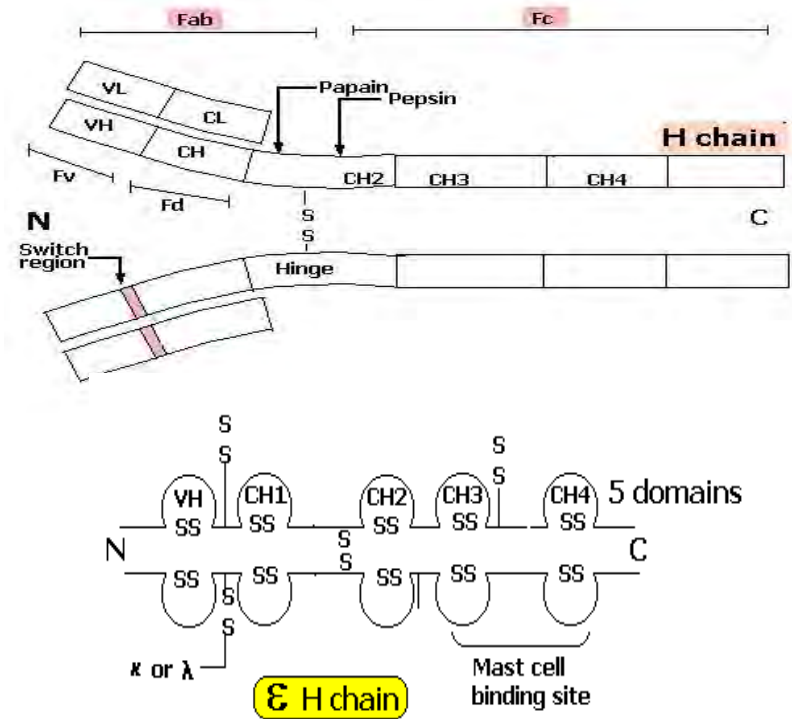


## Properties and functions of immunoglobulins

### Ig M

Ig M is the main immunoglobulin produced early in primary immune response. It is present on the surface of all uncommitted B lymphocytes. IgM is a pentamer and the valence is 10. It is present largely in blood. It is frequently associated with the immune response to

Antigenically complex, blood borne infectious agents. Ig M is the most efficient immunoglobulin in agglutination, complement fixation and other antigen antibody reactions. It is a potent activator of classical pathway of complement. This antibody does not cross placenta. It plays an important role in the defense against bacterial and viral diseases.



### Ig G

Ig G has two identical antigen binding sites and is bivalent. There are four subclasses namely Ig G1, Ig G2, Ig G3 and Ig G4. Ig G is the predominant antibody in secondary immune response. It plays an important role in defense against bacteria, viruses. It also neutralizes toxins. It crosses placenta and is found in large quantities in newborns.

### **Ig G subclasses:**

Structure: they differ in number and arrangement of interchain disulfide bonds.

Effector functions	IgG1	IgG2	IgG3	IgG4
C classical pathway	++	+	+++	--
Placental transfer	+	+	+	+
Binding to Staph Protein A	+++	+++	-	+++
Binding to strep protein G	+++	+++	+++	+++
Binding to Fc $\gamma$ RI	+++	-	+++	++
Binding to Fc $\gamma$ RIIIa	+	-	+	-
Binding to Fc $\gamma$ RIII	+	-	+	-

### **Ig A**

Ig A is found mainly in secretions like milk, tears, saliva and secretions of respiratory, intestinal and genital tracts. It protects the mucus membranes against microbial attack. Many microbes enter the body through these mucus membranes and Ig A offers the first line of defense. Each IgA molecule consists of two H<sub>2</sub>L<sub>2</sub> units and a J chain and a secretory component. The secretory component is a polypeptide synthesized by epithelial cells and it helps IgA to pass the mucosal surface, and resists digestion by intestinal digestive enzymes.

### **IgE**

IgE antibody is present in increased quantities in allergic individuals. The Fc portion of the molecule binds to mast cells and eosinophils. When this antibody combines with its antigen on the mast cell surface, it leads to allergic response.

### **Beneficial role of IgE**

IgE plays a major role in the defense against parasitic worms. Parasites liberate large quantities of allergens in the gut. These stimulate production of IgE and IgG in gut associated lymphoid

tissue(GALT). Mast cells maturing in the GALT are sensitized with IgE. These cells migrate to gut mucosa. They are triggered to release mediators that recruit eosinophils and neutrophils. These cells can kill IgE or IgG coated worms by variety of mechanisms

### **IgD**

IgD has no antibody function. It may act as antigen receptor on cells. In serum it is present in only trace amounts.

### **Points to remember:**

1. IgM antibody is the one which appears first. IgG antibodies appear later and stay for longer times. IgA antibodies offer first line of defense. IgE antibodies are involved in allergic reactions.

## Chapter - 9.4

### ANTIGEN ANTIBODY REACTIONS

#### IMMUNO FLUORESCENCE

##### FLUORESCENCE

Fluorescence is a phenomenon defined as an emission of light of a particular colour by a substance when it is irradiated with light of a different colour.

##### FLUOROCHROMES

Substances which exhibit the phenomenon of fluorescence are called fluorochromes. Fluorochromes are organic substances obtained by synthesis or natural methods.

There are many fluorochromes: For labelling antibodies the Fluorochrome should have the following properties:

1. Should have chemical group capable of forming stable compounds with protein molecules (azo carbamide, thiocarbamide, sulfonamide)
2. Fluorochromes that have not been coupled should be easy to remove.
3. Fluorescent light emitted should be powerful & should decline minimally.
4. Should not contain chemical groups that in combination with a protein could disturb the reaction.
5. The fluorescent colour of the conjugate should be different from that given off by normal cellular substrate (Autofluorescence)
6. The conjugate resulting from the coupling with the protein should be as stable as possible in normal condition of preservation.

7. Immunological reactivity should be retained .
8. Coupling method should be simple
9. Fluorochrome should be easy to synthesise, easy to manipulate, cheap and safe to those who manipulate them.

##### FLUOROCHROMES USED IN IMMUNOLOGY:

1. Fluorescein isothiocyanate (FITC)
2. Lysamine – rhodamine B-200 Sulphonyl chloride
3. Rhodamine B isothiocyanate (RBITC)

##### FLUOROCHROME LABELLING OF IMMUNOGLOBULINS:

General considerations: Serum or gamma globulins can be used for coupling

1. Gamma globulin is better because albumin in sera bind fast and
2.  $\text{NH}_4\text{SO}_4$  is used for precipitation of gamma globulin. It must be removed. Otherwise it competes with gamma globulin for the dye.
3. Another factor is the weight ratio between fluorochrome & proteins.
4. pH of the environment is important. Alkaline pH enhances the speed & amount of coupling.

##### REMOVAL OF EXCESS LABELLED:

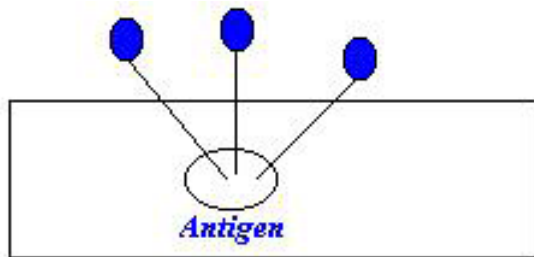
Dialysis, precipitation, adsorption to active charcoal, sephadex gel filtration G25 and ion exchange columns are used.

##### VARIOUS TECHNIQUES OF IMMUNOFLUORESCENCE:

First used by Coon's in 1942 for Pneumococcus in tissue sections.

**Direct technique : or single layer technique**

In this method antigen is treated once with antibody tagged with fluorochrome.

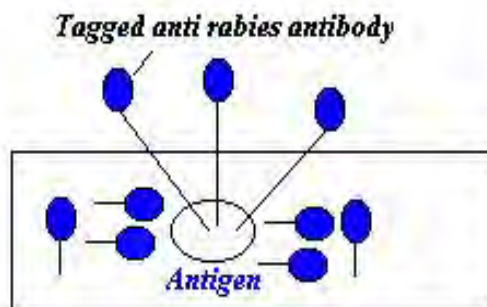


Example: Demonstration of Rabies antigen in impression smear.

1. Impression smear from hippocampus of infected dog is made and fixed

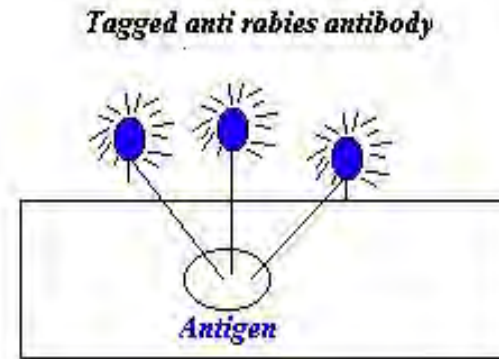


2. It is treated with antirabies antibody tagged with FITC and incubated



3. It is washed to remove un-reacted antibody.

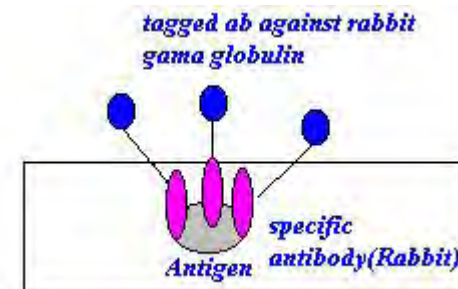
4. The preparation is examined for fluorescence



Similarly various other antigens can be demonstrated.

1. To demonstrate viruses and bacteria in respiratory specimens
2. To demonstrate Adenovirus, Chlamydia in conjunctival smear
3. To demonstrate GC and Mycoplasma in urethral smear.

**INDIRECT TECHNIQUE/ ANTIGLOBULIN METHOD/ DOUBLE LAYER TECHNIQUE:**



**PRINCIPLE:**

To demonstrate the antigen, first unlabelled specific antibody is used. Subsequently it is treated with tagged antibody to gamma globulin. (Thus if the first layer is rabbit antibody then the second layer is anti rabbit gamma globulin- tagged).

## PROCEDURE:

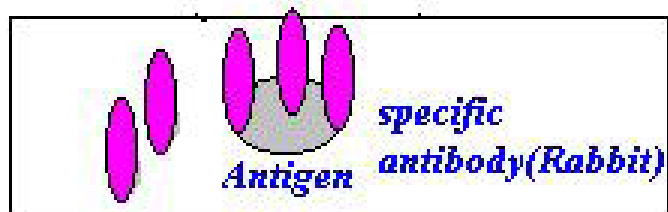
To demonstrate an unknown antigen in fixed preparation. The *test is done in two steps:*

### Step:1

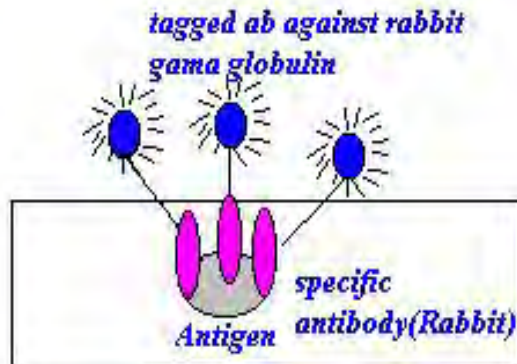
1. Unknown antigen is present in a fixed preparation.



2. It is treated with specific nonfluorescent serum



3. Incubated at 37°C for 10 – 20 min in wet chamber



4. Washed 3 – 4 successive baths 5 min each in phosphate buffered

saline. Antigen antibody complex is resistant to washings. The preparation is washed & dried.

### Step 2

1. To the washed dried preparation labeled anti species anti-globulin is added and incubated at 37°C for 15 – 30 minutes in wet chamber. It is washed and dried as in step 1.

When antigen – antibody complex has been formed in the first step, labelled antiglobulin will couple to specific antibody to antigen and a finely fluorescent complex will be formed.

## INDIRECT METHOD

Indirect method can be used for the detection of unknown antiserum with known antigen:

It is also used for the detection of unknown organism using known antiserum:

## USES:

### In bacteriology

It is used for typing, differentiation, identification, rapid diagnosis of bacteria and bacterial infections.

### For Mycoplasma

For demonstration in tissue culture, Intra cellular location and for pleuro pneumonia like organism etiology of primary atypical pneumonia by FA technique.

### Chlamydia

This test is used for demonstration and quantitation in infected cells

### In virology:

Immunofluorescent test is used for the following

1. Identification of viral antigens in various substrates

2. Establishing the site in the host cell where the antigens are synthesized
3. Identification & quantitation of antibody in sera
4. Dynamics of replication of viruses
5. Establishing the pathogenesis of some viral infections
6. Etiological diagnosis of some human and animal viral infections

### COMPARISON OF DIRECT AND INDIRECT METHODS

	<b>DIRECT</b>	<b>INDIRECT</b>
<i>Sensitivity</i>	Less	High (10 times higher than direct)
<i>Application</i>	Narrow Every antibody must be labelled eg: anti brucella labelled antibody anti typhi labelled antibody anti toxoplasma labelled antibody	one labelled antibody. anti globulin from a species Many different tests can be put up. eg: anti brucella, anti typhi anti toxoplasma antibody (rabbit), labelled rabbit anti gamaglobulin.
<i>Antibody titre</i>	May not be very high  Isolation and purification difficult.	High titre can be obtained.  Isolation and purification easy
<i>Specificity</i>	High (very few cross reactions)	May be low (cross reaction due to infection in animals)

### **Points to remember**

1. Fluorescence is a phenomenon defined as an emission of light of a particular colour by a substance when it is irradiated with light of a different colour
2. Substances which exhibit the phenomenon of fluorescence are called fluorochromes.
3. Fluorochromes are attached to immunoglobulins to trace the antigen – antibody reactions.

## Chapter - 9.5

### ELISA

ELISA is an immuno assay which uses labelled reagents for detecting antigens and antibodies. The test is exquisitely sensitive. It is also very economical in the use of reagents. This test is the most widely used one of all immunological assays because large number of tests can be performed in short time. This can also be automated.

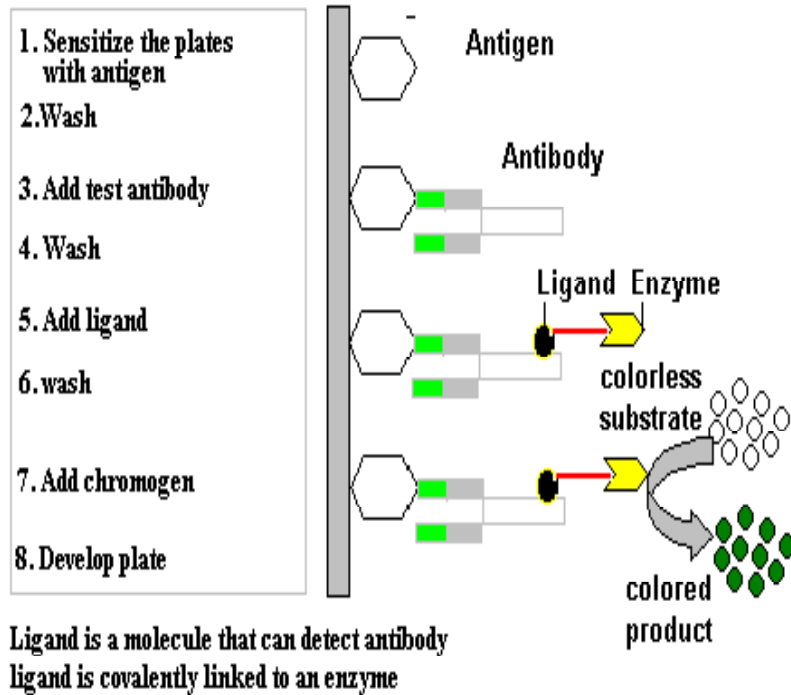


Fig. 9.5-1 Direct method to detect antibody

As in immunofluorescence assay a direct and indirect ELISA test can be done.

### DIRECT ELISA:

In the direct test solid phase (plastic plates) is sensitized with the antigen. In other words antigen is coated onto the solid phase. It is washed to remove unattached antigens. The test antibody is added and allowed to react with the antigen and excess unreacted antibody is washed off. Then a ligand containing enzyme is added which binds to the antibody molecule.

The enzyme used may be either alkaline phosphatase or Horse radish peroxidase. After washing, to remove the unattached ligand, the substrate for the enzyme used is added. If the enzyme is attached through the ligand to antibody molecule, it will react and release a chromogenic compound (coloured substance).

### Indirect binding assay

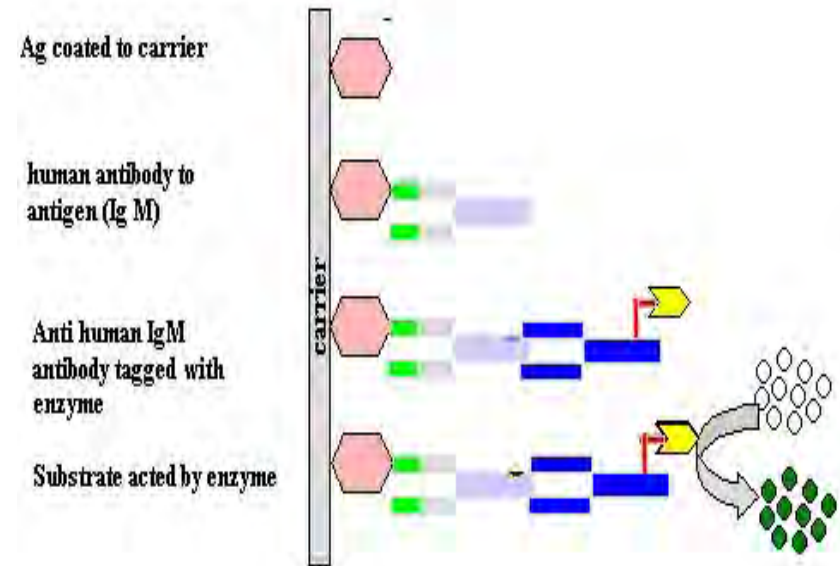


Fig. 9.5-2 Indirect binding assay

The final intensity of the colour is read with the help of a spectrophotometer.



In the indirect assay method an antigen is coated on to the surface of polystyrene wells. The specimen containing specific immunoglobulin for the suspected antigen is added followed by the enzyme labelled specific immunoglobulin (conjugate).

In a positive case, an invisible antibody-antigen complex is formed. The complex is made visible by the addition of a substrate, which the enzyme in the conjugate alters to produce a colour change. This reaction can be seen by the naked eye or measured by electronic means such as a spectrophotometer.

In the indirect method the antibody to immunoglobulin is tagged with the enzyme and not to the antibody that reacts with the antigen.

#### **APPLICATIONS:**

The ELISA technique offers important advantages over several other techniques used for the identification of viruses. These advantages include lower cost for supplies, greater sensitivity, and better reagent stability.

ELISA is used for the identification of the viral pathogens such as Hepatitis B virus, Rota viruses, Cytomegalo viruses, Herpes viruses, Rubella, bacteria such as species of Legionella, Streptococcus, Neisseria, Staphylococcus, and the protozoon Toxoplasma gondii etc. The detection of IgM and IgG antibodies is also possible with this technique.

The application of ELISA is reliable for the rapid detection of various viral infections, including Herpes Simplex virus 2, infectious mononucleosis, polio, Hepatitis B, mumps and measles.

#### **Points to remember:**

1. ELISA is enzyme linked immunosorbent assay.

2. Invisible antigen antibody complexes are made visible by tagging the antibody with enzymes and reacting with its substrate to produce a coloured end product.
3. This test is highly sensitive and is very useful for detecting pathogens or antibodies.

## Chapter - 9.6

### HYPERSENSITIVITY REACTIONS

Although immune system is protective, the same immunologic mechanisms that defend the host may some times result in severe damage to tissues and cause death occasionally. The harmful reaction as the result of antigen and the products of immune response results in hypersensitivity. This type of immune response may be immediate or delayed.

For hypersensitivity reaction to occur the individual should have initial contact with the allergen [antigen] which leads to sensitizing B or T cells. This is called as sensitizing or priming dose. Subsequent contact with the allergen causes manifestations of hypersensitivity. This is called as shocking dose.

#### Classification of hypersensitivity reactions:

Hypersensitivity reactions can be broadly classified into immediate and delayed hypersensitivity reactions.

Immediate hypersensitivity reactions are as follows.

1. Type I hypersensitivity – Anaphylaxis (Reaginic)
2. Type II hypersensitivity – cytotoxic and cytolytic reactions
3. Type III hypersensitivity – Immune complex disease

Delayed hypersensitivity reaction is also called

4. Type IV hypersensitivity or Delayed hypersensitivity.

These hypersensitivity reactions are classified based on the time required for a sensitized host to develop clinical reactions once he is exposed to an antigen.

Immediate hypersensitivity	Delayed hypersensitivity
1. Appears and recedes quickly.	1. Appears slowly and lasts longer.
2. Induced by antigens or haptens by any route.	2. Induced by infection, injection of antigen intradermally or with adjuvants or by skin contact.
3. Circulating antibodies are present and responsible for reaction.	3. Circulating antibodies may be absent and not responsible for reaction.
4. Antibody mediated reaction.	4. Cell mediated reaction.
5. Passive transfer possible with serum.	5. Cannot be transferred with serum but can be transferred by lymphocytes.
6. Desensitization easy does not last long.	6. Desensitization difficult but long lasting.

#### Type I hypersensitivity reaction:

##### Definition:

Type I hypersensitivity reactions are initiated by antigens reacting with cell bound antibody usually IgE. IgE is called reaginic antibody. IgE antibodies are cytotropic antibodies because they are fixed on the surface of tissue cells such as mast cells and basophils. The antigen combines with the cell fixed antibody leading to release of pharmacologically active substances (vasoactive amines) which produce clinical reaction.

- Clinical syndromes of Type I hypersensitivity are Anaphylaxis and Atopy
- Anaphylaxis (Ana – without; prophylaxis – protection)

Anaphylactic hypersensitivity can be passively transferred from a sensitive donor to a normal recipient by injection of serum. It is caused by IgE (reaginic antibody).

## Mechanism of anaphylaxis:

IgE antibody is a cytotoxic antibody. It has affinity for mast cells and basophils. So it will be attached on the surface of mast cells and basophils. When an allergen enters it will cross link to antibody molecules that are attached to the membrane of the mast cells. This causes an influx of  $\text{Ca}^{2+}$  and a decrease in the level of cAMP. As a result of this, degranulation of mast cells occurs and primary and secondary mediators of anaphylaxis are released. Primary mediators are Histamine, serotonin and secondary mediators are prostaglandin and platelet activating factor. These mediators cause different types of anaphylaxis.

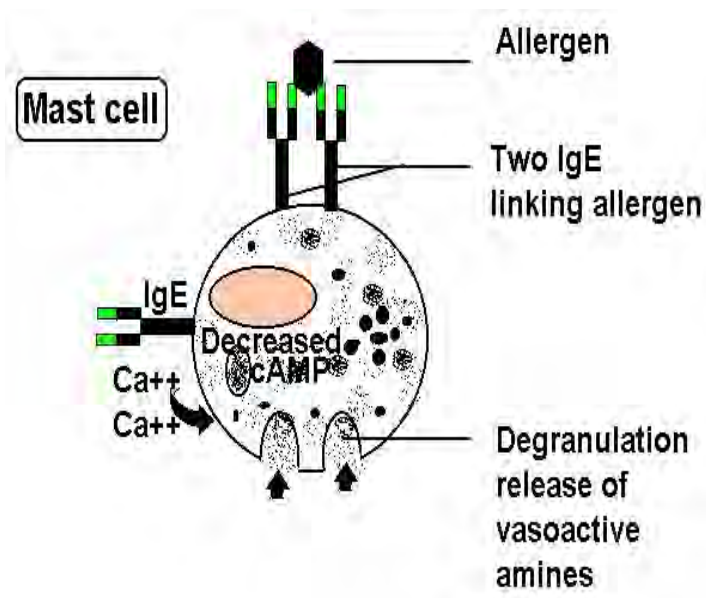


Fig. 9.6-1 Mast Cell

**Types of Anaphylaxis :** Anaphylaxis is categorized as follows.

1. Cutaneous anaphylaxis
2. Passive cutaneous anaphylaxis
3. Anaphylaxis invitro

## Cutaneous anaphylaxis

When a small shocking dose of an antigen is given intradermally to a sensitized host, there will be local “*wheal and flare*” response [local response [local anaphylaxis]. Wheal is a pale, central area of puffiness due to edema, which is surrounded by a hyperemia and erythema [redness]. Cutaneous anaphylaxis is useful in testing hypersensitivity of sensitized individuals hence a syringe loaded with adrenalin should always be kept ready to counteract the adverse effects of anaphylaxis.

## Passive Cutaneous anaphylaxis [PCA]

This is an extremely sensitive *invivo method* for detecting antibodies. A small volume of antibody is injected intradermally into a normal animal. If antigen, along with a dye such as *evans blue* is injected intravenously 4–24 hours afterwards, there will be an immediate bluing at the site of intradermal injection due to vasodilation and increased capillary permeability.

## Anaphylaxis in-vitro

Guinea pigs should be sensitized with a known antigen. Tissues are isolated from guinea pig and placed in Ringer’s Solution. When a specific antigen is added to the bath, the tissues will contract vigorously[fast]. This is called as “Schultz – Dale phenomenon”.

## Atopy

The term *Atopy* means out of place or strangeness. The antigens commonly involved in atopy are characteristically inhalants. Eg – Pollen, house dust or ingestants. Eg – Eggs, Milk. Some of them are contact allergens, to which skin and conjunctiva are exposed. The atopens [antigens] are not always good antigens but induce IgE antibodies.

## Hay Fever [Allergic Rhinitis]

It is an example of an atopic allergy involving the respiratory tract. Initial exposure involves air-borne allergens such as plant pollen, fungal spores, house dust mites, and they sensitize mast cells located within the mucous membranes. Re-exposure to allergen causes the typi-

cal anaphylactic responses like itchy & teary eyes, congested nasal passage, and coughing and sneezing.

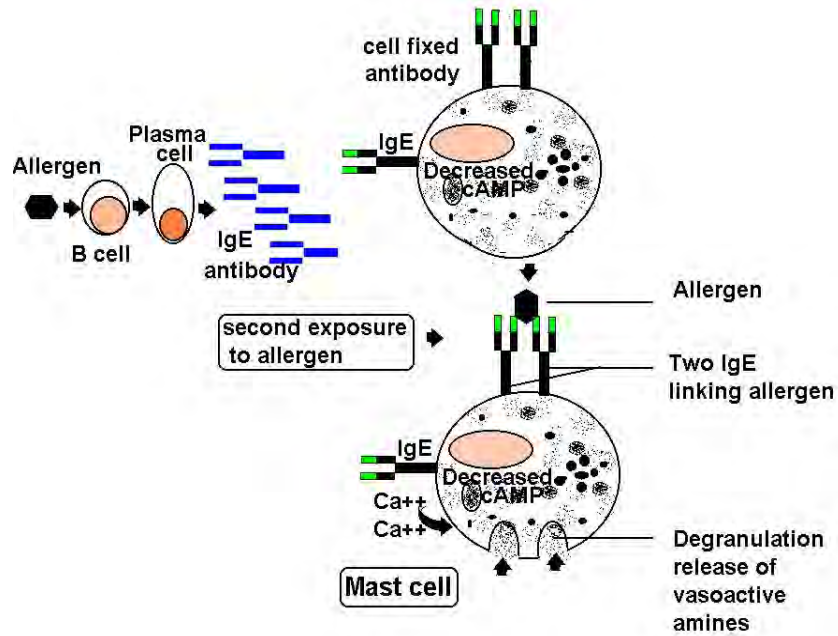


Fig. 9.6-2 Mechanism of Type I hypersensitivity reaction

### Demonstration of IgE antibodies

IgE can be detected by passive hemagglutination and by RAST. [Radio Allergo Sorbent Test].

### Therapy

1. Antihistamines can be given.

## TYPE II HYPERSENSITIVITY REACTIONS

[Cytotoxic Reactions]

### Definition

Cytotoxic type II reactions are initiated by antibody usually, IgG or IgM reacting with cell bound antigen.

### Mechanism of pathogenesis

IgG or IgM antibodies react with the antigen on the surface of cells (RBC.). This antigen – antibody reaction activates complement cascade. This results in opsonization and phagocytosis and later cell death or lysis.

### Clinical Features

Many types of cytotoxic reactions can be grouped according to the nature of target cells or tissue damage that occurs in the reaction.

1. Red blood cell lysis is the most important clinical phenomenon associated with cytotoxic reactions. Example is incompatible transfusion reactions

### Transfusion reactions

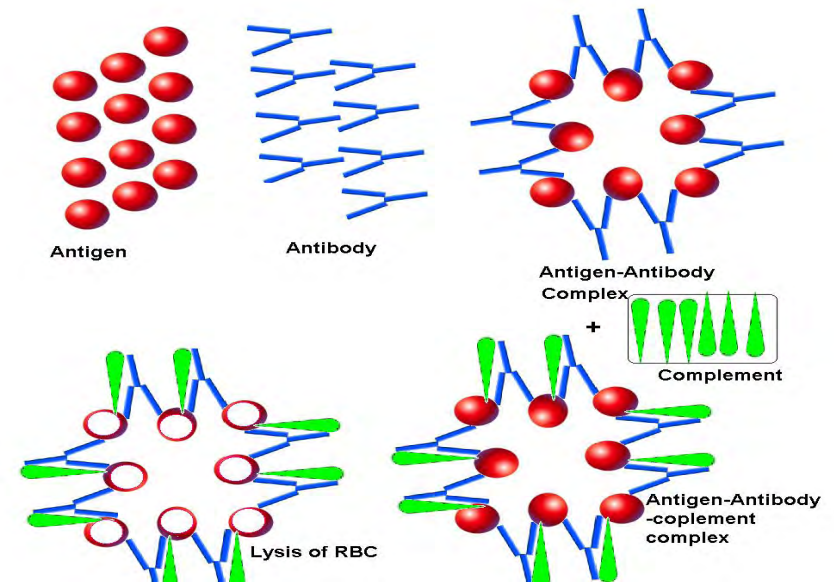


Fig. 9.6-3 Mechanism of Transfusion reactions

### 1.a. Haemolytic disease of the new born

Hemolytic disease of the new born is a potential fatal disease caused by maternal IgG antibodies directed against paternal antigens expressed on fetal red blood cells. The usual target of this response is

the Rh blood group antigen. Maternal anti Rh antibodies cross the placenta to attack the fetal red blood cells. This condition is also called erythroblastosis fetalis.

## 2. Auto immune hemolytic disease

In this disease, the symptoms include fatigue, fever, jaundice and splenomegaly due to the presence of antibodies directed against self red blood cell antigens and result in anemia.

## 3. Drug Induced reactions

Sedormid [Sedative] binds to platelets and causes thrombocytopenic purpura.

Chloramphenicol binds to WBCs and leads to agranulocytosis.

Phenacetin [tranquilizer] binds to RBC and induces hemolytic anemia

4. In rheumatic fever antibodies against group A streptococci cross react with cardiac tissues

## TYPE III HYPERSENSITIVITY

### [Immune Complex mediated disease]

#### Definition

Immune complex mediated reactions are initiated by antigen – antibody [immune] complexes that either are formed locally at the site of tissue damage or are deposited there from the circulation.

#### Types & Examples

Arthus reaction and Serum Sickness are examples of type III hypersensitivity reactions

#### 1. Arthus Reaction

In 1903, Arthus observed this reaction in rabbits when they were injected subcutaneously with horse serum. Initial injections were without any local effect, but with later injections, edema, induration and hemorrhagic necrosis resulted. This is called as Arthus reaction.

## Mechanism of Arthus reaction

When an antigen is injected intradermally it combines with antibody in the serum to form antigen – antibody complexes [Immune complex]. These immune complexes activate complement. Complement causes mast cell degranulation and attract neutrophils into the tissue. As a result of mast cell degranulation vasoactive amines such as histamine & leucotrienes are released. These increase the blood flow and capillary permeability. Lysosomal enzymes cause inflammation of the blood vessel endothelial membrane. As a result of the accumulation of immune complexes small thrombi are seen in blood vessels which cause reduced blood supply and lead to tissue necrosis.

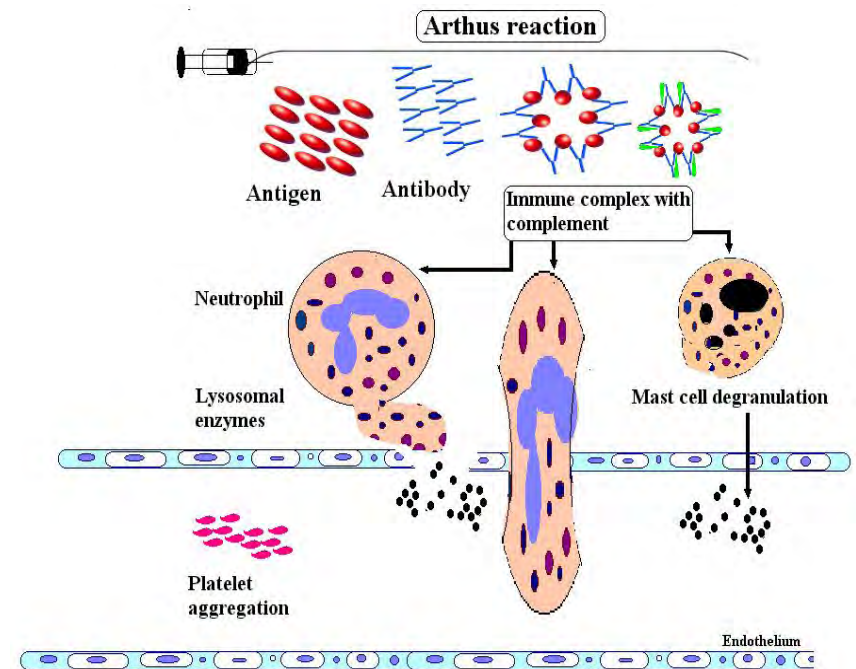


Fig. 9.6-4 Mechanism of Arthus Reaction

## 2. Serum Sickness.

Serum sickness was described by Von Pirquet and Schick in 1905.

This appeared 7–12 days following a single injection of a high concentration of foreign serum.

The clinical syndrome consists of fever, lymphadenopathy, splenomegaly, arthritis, glomerulonephritis rashes etc.

### **Mechanism of Pathogenesis**

The foreign serum and the antibodies against it form immune complexes. These immune complexes get deposited on the endothelial lining of blood vessels in various parts of the body causing inflammatory reaction. With more amount of antibody production these immune complexes are phagocytosed. This reaction becomes self limited.

### **Glomerulonephritis**

Acute post streptococcal glomerulonephritis is a well known immune complex disease. Its onset occurs several weeks after a group A beta hemolytic streptococcal infection

## **TYPE IV HYPERSENSITIVITY-**

### **Delayed type hypersensitivity(DTH)**

In Type IV hypersensitivity the antigen activates specifically sensitized T lymphocytes leading to the secretion of lymphokines, which mediate this hypersensitivity. It is a delayed type hypersensitivity. Two types of delayed type hypersensitivities are recognized.

They are

- (1) Tuberculin type
- (2) Contact dermatitis type

#### **1. Tuberculin type**

This form of hypersensitivity was described by Robert Koch. He observed that when patients with tuberculosis were given a subcutaneous injection of tuberculin [a lipoprotein antigen derived from tubercle bacilli], they developed fever & generalized sickness, and the injection site swelled and hardened.

### **Mechanism of tuberculin hypersensitivity**

When a small dose of tuberculin is injected intradermally in an individual sensitized to tuberculo-protein, after 12 hours lymphocytes begin to migrate from local blood vessels.

These lymphocytes go to the site of the antigen along with macrophages. These lymphocytes & macrophages react with the antigen and produce erythema & induration after 24–48 hours of the injection.

#### **2. Contact dermatitis hypersensitivity:**

Delayed type hypersensitivity sometimes results from skin contact with a variety of chemicals such as nickel, chromium, picryl chloride, drugs such as penicillin.

### **Mechanisms of Contact dermatitis**

These drugs or chemicals applied on the skin behave like haptens.

When these haptens combine with skin proteins, which act as carrier they form hapten-carrier complex. Antigen presenting cells[APC] carry this hapten-carrier complex to the lymphatics, from the lymphatics they go to the regional lymph nodes.

In the lymph nodes the antigen presenting cells present the hapten-carrier complex to the T-cells[CD<sup>4</sup> T cells]. These CD<sup>4</sup> T cells recognize the hapten-carrier complex<sup>4</sup> and release lymphokines or interleukins.

These interleukins activate the T-cells and macrophages, which in turn degrade the lesions varying from macules and papules to vesicles that breakdown leaving behind raw weeping areas typical of acute eczematous dermatitis. These reactions appear after 24–48 hours. This is called as contact dermatitis.

This hypersensitivity can be detected by a *Patch Test*.

### Tests for delayed type hypersensitivity

- Tuberculin skin test for tuberculin type hypersensitivity.
- Patch test for contact dermatitis.

### Therapy.

Avoid the use of allergens. Inflammatory response is reduced with the use of aspirin. Other immunosuppressive drugs can also be used.

### Points to remember

1. The harmful reaction of the immune system is the hypersensitivity reaction. This type of immune response may be immediate or delayed.

The immediate type reaction is antibody mediated and the delayed type is cell mediated. Together there are four types.

2. Type I immediate hypersensitivity reactions are initiated by antigens reacting with cell bound antibody usually IgE.

Ig E is called reaginic antibody. In type I, the antigen when combines with cell bound antibody, pharmacologically active substances are released and they produce clinical reactions.

3. Type II reactions are mediated by IgG or IgM antibodies which react with cell bound antigens. The antibodies react with antigens present on the RBCs.

The specific antibody for the RBC antigen combines with the antigen and there is lysis of RBC.

4. Type III reactions are mediated by antigen antibody complex. Either they are formed locally at the site of tissue damage or are deposited there from the circulation. Glomeronephritis comes under this type.
5. Type IV It is a cell mediated (T cell) delayed type hypersensitivity. They are tuberculin type and contact dermatitis hypersensitivity.

## Chapter - 9.7

### TISSUE TRANSPLANTATION

Transplantation in immunology means the transfer of cells, tissues or organs from one site to another. Many diseases can be cured by implantation of healthy organ or tissues or cells (a graft) from one individual (the donor) to another who is in need of a transplant (the recipient or host). The immune system protects the body from attack by foreign agents, and the same mechanism rejects grafts from anyone who is not genetically identical to the recipient.

Alexis Carrel reported the first transplantation in 1908. He interchanged both kidneys in nine cats. Some transplanted cats maintained urinary output for 25 days. Even though all the cats died, it was established that the transplanted organ could carry out normal function. Then in 1935 a Russian scientist attempted first human kidney transplantation. But the patient died because the kidney was rejected. Then the first successful human kidney transplantation was carried out in Boston in 1954 between identical twins.

Nowadays kidney, pancreas, heart, lung, liver, bone-marrow and cornea transplantations are performed even among non-identical individuals.

#### Immunological basis of graft rejection:

The immune response to a graft varies with the type of graft.

**Autograft** is self-tissue transferred from one body site to another in the same individual. This is done usually in burn patients.

**Isograft** is the tissue transfer between genetically identical individuals. In inbred mice the transfer of tissues can be carried out. In humans it is carried out between identical (monozygous) twins.

**Allograft** is tissue transferred between genetically different members of the same species. Example: organ donation from one person to another.

**Xenograft** is the transfer of tissue from one species to another. Example: the graft of a monkey heart into a human.

Autografts and isografts are usually accepted by the host because there is genetic identity between the graft and the host. In the case of allograft, it is recognized as foreign and rejected by the immune system. Xenografts exhibit greatest genetic variations and the grafts are rejected vigorously.

Antigenically similar tissues are called histocompatible, and they do not induce tissue rejection. Tissues that show antigenic differences are called histoincompatible and they induce immune response followed by rejection.

The rejection of foreign tissue is the result of an immune response to cell surface molecules, called histocompatibility antigens. There are two types of histocompatibility complex. They are major histocompatibility complex and minor histocompatibility complex. The major histocompatibility complex is a collection of genes arranged with in a continuous stretch of DNA on 6<sup>th</sup> chromosome in human and on 17<sup>th</sup> chromosome in mice. MHC is referred to as the HLA complex in humans and H<sub>2</sub> complex in mice. There are three classes of MHC genes.

#### Class I MHC genes:

They encode glycoproteins expressed in all nucleated cells. The main function of Class I gene products is the presentation of peptide antigens to T<sub>c</sub> cells.

#### Class II MHC genes:

They encode glycoproteins expressed on antigen presenting cells (Macrophages and B cells). They present the processed antigen to T<sub>H</sub> cells.



### **Class III MHC genes :**

These genes encode mainly the proteins that have immune functions, including components of complement system, and molecules involved in inflammation.

T cells play a key role in allograft rejection. Rodents born without a thymus have no mature T cells and cannot reject transplants. In normal rats if the thymus is removed before mature T cells are released or irradiated, they cannot reject grafts. If T cells are inoculated into these animals again, they regain the ability to reject grafts.

### **Blood Group Typing**

Before doing transplantation the cells of donors and recipient should be matched by matching blood group antigens and histocompatibility antigens.

Donors and Recipients are typed for RBC antigens. Differences in blood group antigens and MHC antigens are responsible for most of the graft – rejections.

Various tissue typing procedures have been developed to find out the potential donor and recipient. Initially both are screened for ABO blood – group compatibility. The blood group antigens are expressed on RBCs, epithelial cells and endothelial cells. If antibodies are produced to any of these antigens present on the graft that will induce antibody mediated complement lysis.

### **MHC antigen typing:**

HLA typing of potential donors and a recipient can be detected with a microcytotoxicity test. In a microtitre plate, white blood cells from the donors and recipient are distributed into a series of wells and then antibodies specific for various Class I and Class II MHC alleles are added to different wells. After incubation complement is added to the wells. If the white blood cells contain MHC antigens for which specific antibody is added, the cells are lysed upon addition of comple-

ment. These dead cells will take up a dye such as trypan blue. Antibody mediated microcytotoxicity will indicate the presence or absence of MHC allele.

Cell mediated graft rejection occurs in two stages:

1. Sensitization stage
2. Effector stage.

### **Sensitization stage:**

During this phase CD<sub>4</sub><sup>+</sup> and CD<sub>8</sub><sup>+</sup> T cells recognize the allo antigens (antigens present on the allograft) and proliferate in response. Both major and minor histocompatibility antigens are recognized. Host T<sub>4</sub> cell becomes activated when it interacts with an antigen – presenting cell. Recognition of the alloantigens expressed on the cells of a graft induces vigorous T cell proliferation in the host. The major proliferating cell is the CD<sub>4</sub><sup>+</sup> T cell, which recognizes Class II alloantigens. This amplified population of activated T<sub>H</sub> cells is thought to play a central role in inducing the various effector mechanisms or allograft rejection.

### **Effector stage:**

A variety of effector mechanisms participate in allograft rejection. The most important ones are cell mediated (T cell mediated) reactions which include delayed type hypersensitivity and cytotoxic lymphocyte mediated cytotoxicity. Antibody plus complement mediated lysis and antibody dependent cell mediated cytotoxicity are less common.

Graft rejection depends upon the type of tissue or organ grafted and also the immune response. Hyper acute rejection occurs within the first 24 hours, after transplantation. Acute reaction begins in the first few weeks after transplantation and chronic rejection reactions occur from months to years after transplantation.

### **Immune suppression:**

Allogenic transplantation needs some amount of immunosuppression if the transplant is to survive. But the immunosuppressive drugs act against all the antigens, which place the recipient at great risk of infection. Patients on long term immunosuppressive therapy are at increased risk of cancer, hypertension and other diseases.

Azathioprine is given just before and after transplantation. It inhibits mitosis. Both B and T cell proliferation is decreased in the presence of Azathioprine. Corticosteroids such as prednisone act as an anti-inflammatory agent. Cyclosporin A and Rapamycin are fungal metabolites with immunosuppressive properties. Lymphocytes are extremely sensitive to X-rays, so X-ray irradiation can be used to eliminate them in the transplant recipient just before grafting.

The most commonly transplanted organ is the kidney. Many common diseases such as diabetes and various types of nephritis result in kidney failure, as a result transplantation is required.

### **Graft versus – host disease:**

In leukemia, the patients are treated with cyclophosphamide (immunosuppressive drug) and the body is irradiated to kill all cancerous cells. Now this patient is immunosuppressed and will not reject any graft.

To have normal immune function (to fight infections etc) bone marrow cells which contain immunocompetent cells are transplanted from normal donors. In this case the bone marrow cells are not rejected by the recipient, but instead the immunocompetent cells present in the bone marrow, recognize the recipient tissues as foreign and reject the host.

This happens after activation, proliferation and production of cytokines leading to inflammatory reactions. This is called graft versus host (GVH) reaction. The reactions occur in the skin, gastrointestinal tract and liver. In severe GVH reaction liver failure occurs.

### **Points to remember:**

1. Transplantation is the transfer of cells, tissues or organs from one place to another in the same person or from one person to another.
2. Body recognizes foreign substances and fight against them by producing antibody or inducing cell mediated immunity.
3. The rejection of foreign tissues is the result of an immune response against cell surface molecules called histocompatibility antigens. There are three classes of MHC genes that play an important role in the rejection.
4. Before doing transplantation the cells of donor and recipient should be matched by matching blood group antigens and also histocompatibility antigens.
5. The immunity of the recipient is also suppressed by immunosuppressive drugs and corticosteroids to avoid rejection.
6. The most commonly transplanted organ is the kidney.

## Chapter 9.8

### VACCINES (IMMUNIZING AGENTS)

#### Introduction

Immunizing agents prevent the occurrence of disease by giving protection to the host. There are three ways by which one can prevent infections. One way is by reducing the exposure to pathogenic microorganisms. Another way is by acquiring immunity to the particular pathogen. The third way is by using antimicrobial agents to prevent colonization and infection.

#### IMMUNIZATION

It is the process by which an individual resists and overcomes infection by acquiring resistance. This resistance can be natural or artificially acquired. Resistance can be artificially acquired by the use of immunizing agents. There are two types of immunization:

1. Active immunization
2. Passive immunization

#### Active immunization

Active immunization involves the vigorous participation of the immune system to produce resistance. It may be achieved by giving 1. Live attenuated vaccine, 2. Killed/inactivated vaccine, 3. Toxoids, 4. Recombinant DNA vaccine, 5. Synthetic peptides, 6. Internal image antibody or by 7. DNA vaccines.

#### Live attenuated vaccine

Administration of live attenuated vaccine generally results in subclinical or mild clinical illness to limited extent. It provides both local and durable humoral immunity. It also induces cell mediated immunity.

#### Killed or inactivated vaccine

Killed or inactivated vaccine gives immunogenicity without

infectivity. It generally results in antibody production and the CMI is not induced.

#### Passive immunization

Passive immunization involves administration of preformed antibody obtained from humans or animals those have been actively immunized.

#### EXAMPLES OF AGENTS USED FOR ACTIVE IMMUNIZATION

Bacterial Vaccines	Type	Administration Frequency
Typhoid vaccine (TAB)	killed organisms	S/C in two doses
Cholera vaccine	killed	S/C 6 months
Plague vaccine	killed	S/C in 3 injections, 0.5 ml 1 week apart
BCG	Live attenuated	I/M soon after birth
Tetanus/diphtheria	Toxoid	I/M infancy & childhood. Adults every 10 years
<b>Viral Vaccines</b>		
Poliomyelitis	Live attenuated Inactivated	oral polio vaccine injectable vaccine
Mumps/measles/rubella	Live attenuated	S/C once
Yellow fever	Live attenuated	S/C once /10 year
Hepatitis B	Inactivated	I/M 3 doses
Passive immunization is carried out in the following infections		
<b>In Bacterial Infections</b>		
1. DIPHTHERIA	Diphtheria antitoxin	I/M or I/V 10,000 to 100,000U
2. TETANUS	Tetanus immunoglobulin (TIG)	I/M 250 U
3. PERTUSIS	Pertusis immunoglobulin	I/M 1.5 ml at an interval of 5-7 days
4. BOTULISM	Botulinum antitoxin	I/M or I/V
<b>Viral Infections</b>		
1. RABIES	Human rabies immunoglobulin	I/M two doses
2. HEPATITIS B	Hepatitis $\beta$ immunoglobulin	I/M two doses
3. MEASLES	Immunoglobulin	I/M
4. VARICELLA-	Hyperimmune serum From immunized donors	I/M
5. EBOLA VIRUS	Serum from convalescent persons	I/M

**Vaccines :** Vaccines are live or killed microorganisms or their products, which are used for immunization. There are different kinds of vaccine known. They are killed/inactivated vaccines, live attenuated vaccine, Sub unit vaccine, Recombinant DNA vaccine, Synthetic peptide vaccine, Internal image antibody vaccine, or DNA vaccine.

**Killed/inactivated vaccine:** This type of vaccines are prepared by killing the microorganisms by heat, formalin, alcohol, phenol, U-V light or Beta propiolactone. Any one of these methods inactivates the microorganisms. Examples of inactivated vaccines are TAB vaccine for enteric fever (Bacterial vaccine) and Salk polio vaccine (Viral vaccine).

**TAB vaccine :** TAB vaccine contains 1000 million *S. typhi*, 750 million *S. paratyphi A* and *S. paratyphi B* in 1 ml. These organisms are killed by heating at 50-60°C and preserved in .5% phenol. The vaccine is given in two doses of 0.5 ml subcutaneously at an interval of 4-6 weeks. In India, TAB vaccine has been replaced by the divalent typhoid-paratyphoid A vaccine eliminating paratyphoid B that is very rare in the country.

**Advantages of killed vaccine :** Killed vaccines are safe because they do not revert back to live or virulent forms

**Disadvantages of killed vaccines :** 1. Immunity lasts for short period of time 2. Booster dose is required.

### LIVE ATTENUATED VACCINES

**Attenuation:** It is the loss of virulence of microorganisms that they are antigenic but not pathogenic. Attenuation can be done by passage of the microorganisms through unfavorable hosts, repeated culturing in artificial media, growing them at high temperatures, growing in presence of weak antiseptics, desiccation (drying), and by prolonged storage of culture. Attenuated organisms are antigenic but not pathogenic. Example: BCG (Bacillus Calmette, Guerin)

**BCG vaccine:** This vaccine is prepared from a strain of *Mycobacterium bovis*. This *M. bovis* is attenuated by 239 serial subcultures in glycerin bile potato medium over a period of 13 years. Injection of BCG leads to dissemination and multiplication of the bacilli in different organs

with the production of small tubercles. Within a few weeks the bacilli stop multiplying although they survive in the tissues for an indefinite period of time. The lesions do not spread but instead disappear slowly. This self-limited infection induces delayed hypersensitivity and immunity (CMI).

### COMPARISON OF LIVE AND KILLED VACCINES

Characteristics	Killed/ Inactivated	Live attenuated
Immunity	Strong and appropriate	May be weak
Booster Doses	Required	Both humoral and CMI are induced at the site where the immunity is required.
Adjuvants	required	Not required
Safety	Safe if side effects checked	Not safe in immunocompromized persons
Spread	Nil	Vaccine strain spreads in the community

#### Advantages of live attenuated vaccines

1. Immunity lasts for several years.
2. Booster doses are not necessary

#### Disadvantages:

The live organisms may revert to virulent forms

### TOXOIDS

Toxins when treated with formalin is converted into toxoid which retains the antigenicity but loses its toxicity.

Tetanus toxoid and Diphtheria toxoid are used routinely for immunization.

#### Points to remember:

Vaccines are used to protect individuals from infections. Both live and killed vaccines are used. Both of them have advantages and disadvantages.

## Section - I

### GENERAL MICROBIOLOGY

#### Evaluation

#### Part I (Objective types)

##### Division A : Choose the correct answer

1. The discovery of the microbial world of 'animalcules' was made by -
  - a. Robert Koch.
  - b. Edward Jenner.
  - c. Anton Von Leeuwenhoeck.
  - d. Fleming.
2. The theory of spontaneous generation finally was disproved by the work of –
  - a. Jenner & Koch.
  - b. Redi & Spallazani.
  - c. Flory & Chain.
  - d. Pasteur & Tyndall.
3. The system of antiseptic surgery was developed by
  - a. John Tyndall
  - b. Joseph Lister
  - c. Louis Pasteur
  - d. Robert Koch
4. Postulates to establish a causal relationship between a specific microorganism and a specific disease were laid down by
  - a. Jacob Henle
  - b. Theodore Schwann
  - c. Felix Pouchet
  - d. Robert Koch
5. The fermentation of beer and wine by yeast was demonstrated by
  - a. John Needham
  - b. Franz Schulze
  - c. Francesco Redi
  - d. Theodore Schwann
6. The credit of making a compound microscope goes to
  - a. Robert hooke
  - b. Zaccharias
  - c. Knoll
  - d. Zernike
7. Unstained Treponema pallidum is seen through
  - a. Phase contrast microscope
  - b. Electron microscope
  - c. Dark field microscope
  - d. Fluorescent microscope
8. Complete detail of living cell is detectable under
  - a. Phase contrast microscope
  - b. Electron microscope
  - c. Dark field microscope
  - d. Fluorescent microscope

9. Light microscopes have a resolution of
- 0.1  $\mu\text{m}$
  - 0.2  $\mu\text{m}$
  - 0.5  $\mu\text{m}$
  - 0.8  $\mu\text{m}$
10. Fluorescent microscope is used in medical microbiology to observe pathogens such as
- Treponema pallidum
  - Mycobacterium tuberculosis
  - Staphylococcus aureus
  - E. coli
11. Micro organisms may be controlled by
- Removal
  - Inhibition
  - Killing
  - All the above
12. Which of the following is not a heavy metal?
- Mercury
  - Chlorine
  - Silver
  - Copper
13. The concentration of hypochlorite used should provide atleast
- 0.1 ppm of residual chlorine
  - 0.5 ppm of residual chlorine
  - 1 ppm of residual chlorine
  - 0.01 ppm of residual chlorine

14. Copper sulphate is more effective against
- Algae
  - Fungi
  - Bacteria
  - All the above
15. Which of the following is Quaternary ammonium salt
- Copper sulphate
  - Silver nitrate
  - Cetrimide
  - Ferric chloride
16. A collective term to define all the organized essential chemical changes that occur in a living cell is -
- Metabolism
  - Catabolism
  - Anabolism
  - Glycolysis.
17. The process of splitting of sugar to derive energy is a type of catabolism of glucose widely occurring in microorganisms, plants and animals is –
- Respiration
  - HMP shunt
  - Glycolysis
  - Digestion
18. TCA cycle is also known as
- Kreb's cycle
  - Citric acid cycle
  - Amphibolic cycle
  - All the above

19. Enzymes are produced by
  - a. Microbes
  - b. Animals
  - c. Plants
  - d. All the above
20. A substance acted upon by an enzyme is called
  - a. Cofactor
  - b. Coenzyme
  - c. Substrate
  - d. Holoenzyme

**Division B : Fill in the blanks:**

1. Some fungi are single celled like \_\_\_\_\_ and some \_\_\_\_\_ are multicellular.
2. \_\_\_\_\_ are single celled, unicellular eukaryotic microorganisms with atleast one nucleus and numerous intra cellular structures.
3. \_\_\_\_\_ drastically decreased child birth deaths by antiseptic techniques and practices.
4. \_\_\_\_\_ prepared rabies vaccine by injecting the pathogen into rabbits.
5. On July 6, 1885 Pasteur tested his pioneering rabies treatment on \_\_\_\_\_ for the first time.
6. The condenser in a dark field microscope contains an \_\_\_\_\_.
7. Phase contrast microscope was first described by \_\_\_\_\_.
8. Fluorescent microscope exposes a specimen to \_\_\_\_\_.
9. If a specimen does not have natural fluorescence it has to be stained with a fluorescent dye called \_\_\_\_\_.
10. \_\_\_\_\_ is a complex and highly advance microscope.
11. Ultra violet radiation includes rays of \_\_\_\_\_ wave length.
12. Sterilization with gamma rays is also known as \_\_\_\_\_.
13. The credit of introducing antiseptic agents goes to \_\_\_\_\_.
14. \_\_\_\_\_ is used to prevent the gonococcal infection of eyes of new born.
15. Dilute solutions of carbolic acid is \_\_\_\_\_.
16. Metabolism comprises of \_\_\_\_\_ and \_\_\_\_\_.
17. \_\_\_\_\_ is an energy yielding reaction in anaerobes occurring in the absence of oxygen.
18. \_\_\_\_\_ is the most important high energy transfer component found in the cell.
19. In respiration glucose is oxidized to \_\_\_\_\_.
20. \_\_\_\_\_ molecules are formed per molecule of NADH<sub>2</sub> oxidized.
21. \_\_\_\_\_ argued for the one of the antiseptic techniques.
22. \_\_\_\_\_ discovered Petri dish.
23. Pure culture was developed by \_\_\_\_\_.
24. Anthrax bacilli was identified by \_\_\_\_\_.
25. \_\_\_\_\_ developed a porcelain filters to remove bacteria from water in 1884.
26. Phagocytosis was identified by \_\_\_\_\_.

**Division C : Match the following:**

- |      |                            |                                 |
|------|----------------------------|---------------------------------|
| I.   | 1. Spherical bacteria      | A. Tyndallization               |
|      | 2. Sterilization technique | B. Swan necked flask            |
|      | 3. Spontaneous generation  | C. Cocci                        |
|      | 4. Agar                    | D. Tobacco Mosaic Virus         |
|      | 5. Dmitri Iwanoski         | E. Fannie Hesse                 |
| II.  | 1. Dark field microscope   | A. UV                           |
|      | 2. Cone of light           | B. Electron microscope          |
|      | 3. Fluorescent microscope  | C. Phase contrast microscope    |
|      | 4. Knoll and Ruska         | D. Scanning electron microscope |
|      | 5. Photographic plate      | E. Treponema pallidum           |
| III. | 1. Fungicide               | A. gamma rays                   |
|      | 2. Oligodynamic action     | B. Copper oxychloride           |
|      | 3. Malachite green         | C. fumigation                   |
|      | 4. Ethylene oxide          | D. metals                       |
|      | 5. Cold sterilization      | E. Gram positive bacteria       |
| IV.  | 1. Exoenzyme               | A. organic group                |
|      | 2. Endoenzyme              | B. metal ions                   |
|      | 3. Apoenzyme               | C. intracellular enzymes        |
|      | 4. Coenzyme                | D. protein portion              |
|      | 5. Cofactors               | E. extracellular enzymes        |
| V.   | 1. Edward Jenner           | A. Antiseptic theory            |
|      | 2. Lister                  | B. Cell                         |
|      | 3. Antonie von Leevanhoek  | C. Vaccine                      |
|      | 4. John Tyndall            | D. Animal Cules                 |
|      | 5. Robert Kock             | E. Spore formation              |

**Part II -- (Very short answers -- Two marks questions)**

1. Describe the size range of microorganisms.
2. Define viruses.
3. What is theory of Spontaneous generation?
4. What is tyndallization?
5. What is attenuation?
6. Who were involved in making the compound microscope?
7. What are the types of electron microscope?
8. Draw the path of light in dark field microscope.
9. What are the types of microscope?
10. Give two uses of fluorescent microscope.
11. Why microbial control is necessary?
12. What are antiseptic agents? Give examples.
13. What are bactericidal agents? Give examples.
14. What are the uses of different wave lengths of UV rays?
15. What are the methods used for the evaluation of antimicrobial action?
16. Define Metabolism
17. Define Anabolism
18. Define Catabolism
19. Define Glycolysis
20. Define Fermentation.
21. Who was the first person to see microorganisms ?
22. Define spontaneous generation.
23. What is the gene theory of disease ?
24. Define infectious disease.
25. What is chemotherapy ?
26. When was the golden age of microbiology ?



27. Why is the study of microbiology important ?
28. What is the antiseptic theory ?
29. Define Immunology.
30. What is an Antibiotic ?
31. What is an attenuated culture ?
32. Who discovered the antibiotic streptomycin ?
33. Who has suggested the use of agar-agar for culture media ?

**Part III -- (Short answers -- Five marks questions)**

1. State the Koch's postulates.
2. What are the contributions of Leeuwenhoek to microbiology?
3. Elaborate phase contrast microscope.
4. What are the basic steps involved in electron microscopy?
5. Write a short note on the control of microorganisms by radiation.
6. List out the methods of controlling microorganisms with suitable examples.
7. Write a short note on Fermentation.
8. Enzyme regulation by feedback inhibition
9. How did Pasteur's famous experiment defeat the theory of spontaneous generation ?
10. Discuss Koch's contribution to the field of microbiology.
11. Discuss the major contribution to microbiology by Alexander Fleming.
12. Explain John Tyndall's contribution to disprove the theory of spontaneous generation.

**Part IV -- (Essay type -- Ten marks questions)**

1. Elaborate on the work of Louis Pasteur.
2. Elucidate electron microscopy.
3. How will you evaluate the antimicrobial action of a disinfectant?
4. Describe the Embden-Meyerhof pathway.

**Section - II**  
**ENVIRONMENTAL MICROBIOLOGY**

**Evaluation**  
**Part I (Objective types)**

**Question A : Choose and write the correct answers :**

1. The World Environment Day is celebrated every year on
  - a) 5<sup>th</sup> July
  - b) 5<sup>th</sup> April
  - c) 5<sup>th</sup> June
  - d) 5<sup>th</sup> May
2. The principle involved in the air sampler Hesse's tube is
  - a) Centrifugal action
  - b) filtration
  - c) settling under gravity
  - d) impingement
3. Droplet nuclei are significant in the transmission of the diseases of
  - a) digestive system
  - b) nervous system
  - c) reproductive system
  - d) respiratory system
4. Air-borne infections are transmitted mainly by
  - a) aerosols from person to person
  - b) inhaling spores or hyphal fragments from soil
  - c) drinking contaminated water
  - d) objects such as handkerchiefs that are contaminated with respiratory secretions.
5. Primary treatment of sewage removes which per cent of BOD?
  - a) 5-10
  - b) 15-20
  - c) 20-25
  - d) 30-40
6. Which of the following is not an aerobic process?
  - a) Activated sludge process
  - b) trickling filter
  - c) sludge digestion
  - d) oxidation pond
7. Copper is used in water treatment as a
  - a) disinfectant
  - b) coagulant
  - c) indicator
  - d) none of the above.
8. Which of the following treatments removes phosphates and nitrates from sewage?
  - a) primary
  - b) secondary
  - c) tertiary
  - d) digester
9. The BOD roughly measured the amount of \_\_\_\_\_ in water?
  - a) degradable organic material
  - b) degradable inorganic material
  - c) oxygen
  - d) all the above
10. The major purpose of primary sewage treatment is to
  - a) reduce the BOD
  - b) remove pathogen
  - c) remove many of the suspended and floating particles
  - d) oxidize the organic constituents
11. The highest percentage of gas present in the atmosphere is
  - a) CO<sub>2</sub>
  - b) O<sub>2</sub>
  - c) N<sub>2</sub>
  - d) SO<sub>2</sub>

**Division B : Fill in the blanks**

1. The first United Nations conference on Environment and Development held at Sewden in the year \_\_\_\_\_.
2. In the environment biochemical changes occur due to \_\_\_\_\_.
3. Widely used coagulant in water treatment is \_\_\_\_\_.
4. Tertiary treatment in sewage treatment is also known as \_\_\_\_\_.

5. The trickling filter is employed for————— treatment.
6. Sludge as a fertilizer is recommended as a source of \_\_\_\_\_.

**Division C : Match the following**

- |                     |                         |
|---------------------|-------------------------|
| 1. Faecal coliforms | a) fertilizer           |
| 2. Cholera          | b) airborne             |
| 3. Droplet nuclei   | c) high organic content |
| 4. Sludge           | d) contaminated water   |
| 5. BOD              | e) indicator            |

**Part II -- (Very short answers – Two marks questions)**

1. Define air pollution.
2. Define aerosol.
3. Mention two important air borne diseases and their causative agents.
4. Mention two important methods of composting.
5. Define composting.
6. Define biogas.
7. Mention two important organisms responsible for biogas production.

**Part III -- (Short answers – Five marks questions)**

1. Write a short note on environmental microbiology.
2. Write critical notes on droplet, droplet, nuclei.
3. Write the impact of Eutrophication.
4. What are the common air-borne diseases and their causative agents ?
5. Write the uses of biogas.

6. Write short notes on oxidation pond.
7. Write critical notes on trickling filter.

**Part IV (Essay type – Ten marks questions)**

1. What are the air pollutants ? Write their sources and their impact on human health.
2. Mention the important methods adopted for sewage water treatment.
3. What are the methods adopted for composting ? Mention the important factors influencing the compost making.
4. Describe the biogas production from organic waste. Mention the organisms, steps involved in biogas production.

**FOOD MICROBIOLOGY**

**Part I**

**Division A : Choose and write the correct answer.**

1. The low pH of fruits is likely to inhibit
 

a) bacteria	b) molds
c) yeasts	d) actinomycetes
2. The most widely used sanitizing agents in food processing area are
 

a) hypochlorites	b) bromine water
c) chlorine dioxide	d) ozone
3. Which of the following is resistant to decomposition ?
 

a) Cellulose	b) hemicellulose	c) fructose	d) lignin
--------------	------------------	-------------	-----------
4. Salts and sugar preserve foods because they

- a) make them acid    b) produce a hypotonic environment  
c) deplete nutrients    d) produce a hypertonic environment.
5. The organisms most often involved in the spoilage of refrigerated fresh meat, poultry and eggs are the species of genus  
a) Bacillus                      b) Pseudomonas  
c) Lactobacillus                d) Streptococcus
6. Which of the following biofertilizers is most suitable for paddy crop ?  
a) Rhizobium    b) Acetobacter    c) Azotobacter    d) Azolla
7. Denitrification results in the formation of  
a) nitrate    b) nitrite    c) ammonia    d) nitrogen
8. The uptake of which of the following minerals is found to be enhanced by the mycorrhizae ?  
a) Sulfur    b) phosphorus    c) calcium    d) magnesium
9. Bacillus thuringiensis is a  
a) Biofertilizer                      b) Biopesticide  
c) Biosurfactant                      d) all the above
10. The water activity of a food can be lowered by  
a) dehydration                      b) drying  
c) freezing                              d) all the above

#### Division B : Fill in the blanks

- Low acid foods are referred as \_\_\_\_\_.
- \_\_\_\_\_ is the first person who identified the presence and role of microorganisms in food.
- Food forms ideal \_\_\_\_\_ for the growth of the microorganisms.
- BGA can be applied for \_\_\_\_\_ crop.
- Foods get contaminated during \_\_\_\_\_.

6. Preservatives are used to reduce the growth and activity of \_\_\_\_\_.

#### Division C : Match the following

- |                         |                          |
|-------------------------|--------------------------|
| 1. Aflatoxin            | a) Fermentation          |
| 2. Ropiness             | b) food poisoning        |
| 3. Botulism             | c) pasteurization        |
| 4. Sourmilk             | d) fungus                |
| 5. Heating              | e) food spoilage         |
| 6. Sorbates             | f) preservatives         |
| 7. Travellers diarrhoea | g) Shigella dysenteriae  |
| 8. Enterotoxin          | h) Clostridium botulinum |
| 9. Neurotoxin           | i) Staphylococcus aureus |
| 10. Bacillary dysentery | j) Escherichia coli      |

#### Part II (Very short answer – Two marks questions)

- Define food poisoning.
- What are the causes for food poisoning ?
- Mention two important chemicals that are used for food preservation.
- Define Humus.
- Define compost.
- Define biofertilizer.
- Define staple foods.
- Define pasteurization.
- Define chemical preservation.
- Write short notes on biogeochemical cycle.

11. Write critical notes on nitrification.
12. Define biopesticide.

**Part III (Short answers – Five marks question)**

1. What are the objectives of food preservation ?
2. Write critical notes on ammonification and denitrification.
3. Write the role of biofertilizers in agriculture.
4. What are the roles of mycorrhizae in Agriculture ? List out important biopesticides. Explain the role of *Bacillus thuringiensis* in controlling the pest.

**Part IV (Essay type – Ten marks questions)**

1. What are the principles of food preservation ? Mention different methods of food preservation for vegetables and fruits.
2. Draw a schematic diagram of nitrogen cycle and mention the important steps and organisms involved in it.
3. Describe the decomposition of organic matter in detail.
4. Describe the sulphur cycle with neat diagram.
5. Write short notes on *Azolla* and cyanobacterium. Write their importance in agriculture.

## INDUSTRIAL MICROBIOLOGY

**Division A : Choose and write the correct answer :**

1. Which of the following is an example of crude medium component ?
  - a) Corn steep liquor
  - b) Molasses
  - c) Soybean meal
  - d) All the above
2. Impellers used in fermentation helps in

- a) Aeration
- b) antifoaming
- c) agitation
- d) absorption

3. Wine can be produced by the fermentation of

- a) Berries
- b) Grapes
- c) Honey
- d) All the above

4. Which of the following is used for the production of wine ?

- a) Acetic acid bacteria
- b) Lactic acid bacteria
- b) propionic acid bacteria
- e) Yeasts

5. Citric acid is recovered by adding

- a) Calcium and sulfuric acid
- b) calcium and hydrochloric acid
- c) Sodium and sulfuric acid
- d) Sodium and hydrochloric acid

6. The maximum number of microorganisms is present in

- a) lag phase
- b) log phase
- c) stationary phase
- d) decline phase

7. In preservation of industrially important culture \_\_\_\_\_ method provides longer periods.

- a) Storage agar slope
- b) storage under liquid nitrogen
- c) Lyophilization
- d) all the above

**Division B : Fill in the blanks**

1. The growth phase of microorganisms passes through many stages in \_\_\_\_\_ culture.
2. \_\_\_\_\_ is the natural source for isolating high yielding

species of microorganisms.

3. In any systematic screening ——— screening is strictly essential.
4. The example for primary screening procedure is ———
5. Auxotrophic mutants are meant for ———.

#### Division C : Match the following

- |                             |                 |
|-----------------------------|-----------------|
| 1. Sodium benzoate          | a) Antibiotic   |
| 2. Penicillin               | b) Absorption   |
| 3. Wine                     | c) Citric acid  |
| 4. Organic acid             | d) Yeast        |
| 5. Immobilization technique | e) Preservative |

#### Part II - (Very short answers – Two marks questions)

1. Define solid culture.
2. Define batch culture.
3. Define primary screening.
4. Define lyophilization.
5. Define antibiotic.
6. Mention two important characters that are required for industrially important microbes.
7. Mention two important methods to select industrially important microbes.

#### Part III - (Short answer – Five marks questions)

1. List out industrially important microorganisms.
2. Describe the primary screening methods to select industrially important microbes.
3. Write critical notes on continuous culture.

4. What are the raw materials required for penicillin production?
5. What are the methods adopted to preserve microbial culture? Explain the storage agar slope method in detail.

#### Part IV (Essay type answer – Ten marks questions)

1. What are the methods adopted to select industrially important microorganisms?
2. Explain how will you improve the strain for industrial purposes.
3. Write the organisms, raw materials, industrial production of penicillin. What are the different types of penicillin ?
4. List out important organic acids. Explain industrial production of citric acid.
5. Describe the industrial process involved in wine production. Write the different types of wine and their alcohol percentage.
6. Define immobilization. Explain the different techniques of immobilization and write the advantages of immobilization techniques.

**Section - III**  
**MEDICAL BACTERIOLOGY**  
**Evaluation**  
**Part I (Objective types)**

**Division A : Choose the best answer:**

1. Fimbrial adhesins are seen in which of the following organisms?
  - a. E.coli
  - b. N.gonorrhoeae
  - c. N.meningitidis
  - d. All the above
2. Adhesion of Streptococcus pyogenes to pharyngeal epithelial cell is mediated by which of the following?
  - a. Fimbriae
  - b. Lipoteichoic acid
  - c. Lipopolysaccharide
  - d. flagella
3. A toxin which has pyrogenic activity is associated with which of the following?
  - a. Exotoxin
  - b. Enterotoxin
  - c. Endotoxin
  - d. All the above
4. Which type of colonies is produced by staph aureus on blood agar?
  - a. alpha haemolysis
  - b. beta haemolysis
  - c. gamma haemolysis
  - d. All the above.
5. Staphylococci are seen as:
  - a. Chains
  - b. Clusters
  - c. Twisted forms
  - d. cone shape
6. Staphylococci are:
  - a. Gram negative
  - b. Gram positive
  - c. Gram variable
  - d. All the above

7. Coagulase is produced by:
  - a. S. aureus
  - b. S.epidermidis
  - c. S.saprophyticus
  - d. S.hemolyticus
8. Streptococci are seen as:
  - a. Clusters
  - b. chains
  - c. long rods
  - d. club shaped form
9. Streptococci are:
  - a. Gram positive cocci
  - b. Gram negative cocci
  - c. Gram positive bacilli
  - d. Gram negative bacilli
10. A zone of complete clearing of blood around the colonies is called:
  - a. Alpha haemolysis
  - b. Beta haemolysis
  - c. gamma haemolysis
  - d. All the above
11. Lancefield grouping is based on :
  - a. Antigenic difference
  - b. Structural difference
  - c. difference in haemolysis
  - d. difference in chain length

12. Hyaluronidase is an enzyme Which acts on
- Cell surface
  - intercellular cement substance
  - cytoplasm
  - nucleic acid
13. Which of the following major antigens is involved in Rheumatic fever episodes?
- flagellin
  - Myosin
  - albumin
  - globulin
14. Necrotizing fasciitis is caused by which of the following?
- Staph.aureus
  - Str.pyogenes
  - C. diphtheriae
  - Clostridium tetani
15. Shigellae are Gram negative
- cocci
  - bacilli
  - spirals
  - comma shaped
16. Shigellae are subdivided in to
- two species
  - eight species
  - four species
  - six species

17. Shigellae cause
- amoebic dysentery
  - bacillary dysentery
  - diarrhea
  - colitis
18. E.coli present in the human intestine represents which of the following?
- Mutualism
  - Parsitism
  - Transient flora
  - carrier
19. Diphtheria toxin acts on which of the following?
- Nucleic acid synthesis
  - Protein synthesis
  - lipid synthesis
  - All the above
20. Vibrio cholerae are -
- Gram negative rods.
  - Gram positive rods.
  - Gram negative curved rods.
  - Gram variable rods.
21. Vibrios are -
- Motile by single flagellum
  - Motile by two flagella.
  - Motile by ten flagella.
  - Motile by more flagella.
22. The somatic antigen is -
- O antigen.
  - H antigen.
  - F antigen.
  - K antigen.



23. The stool of cholera is -
- Blood with mucous.
  - Rice – water stool.
  - Watery stool.
  - Normal stool.
24. Clostridium tetani is a
- Gram positive rod
  - Gram negative rod
  - Gram positive cocci
  - Gram negative cocci
25. How many types of toxins are produced by C. tetani?
- 2 types
  - 5 types
  - 4 types
  - 7 types
26. Clostridium tetani grows in:
- The presence of oxygen
  - in the absence of oxygen
  - both in presence and absence of oxygen
  - presence of carbon di oxide
27. Clostridium botulinum is a gram positive rod with :
- Terminal round spore.
  - Terminal oval spore.
  - Sub – terminal round spore.
  - Sub – terminal oval spore.
28. Clostridium botulinum is motile with :
- Single flagellum
  - Tuft of flagella
  - Peri-trichous flagella
  - No flagella.
29. C. botulinum grows :
- In the presence of oxygen
  - In the absence of Oxygen
  - In the presence or in the absence of oxygen
  - All of the above.

30. C. botulinum spores are –
- Round terminal
  - Round sub – terminal
  - Oval terminal
  - Oval sub – terminal.

**Division B : Fill in the blanks.**

- Adhesion of Streptococcus pyogenes to pharyngeal epithelial cells is mediated by\_\_\_\_\_
- Colonization of Ps.aeruginosa to respiratory epithelial cells is aided by\_\_\_\_\_
- \_\_\_\_\_ of Streptococcus pneumoniae inhibit phagocytosis
- M protein of Streptococcus pyogenes inhibits\_\_\_\_\_
- Bacterial cell wall bound toxic polysaccharide is known as\_\_\_\_\_
- In commensalism \_\_\_\_\_ dealt to either partner
- Prepuberty vaginal pH is \_\_\_\_\_
- On blood agar S.aureus produces\_\_\_\_\_ colonies
- For MRSA strains\_\_\_\_\_ is the drug of choice
- Beta lactamase splits \_\_\_\_\_ molecule
- Peeling of squamous epithelial cells is caused by\_\_\_\_\_ of S.aureus.
- \_\_\_\_\_ is involved in the development of dental caries
- Specific acquired resistance to Streptococcus pyogenes is given by antibodies to \_\_\_\_\_
- The enzyme \_\_\_\_\_ liquifies viscous exudates
- People harbor C.diphtheriae after an attack of the disease as\_\_\_\_\_

16. Resistance to diphtheria depends on the availability of \_\_\_\_\_ in the blood
17. Diphtheria spreads from one person to another by \_\_\_\_\_
18. Diphtheria toxin inactivates \_\_\_\_\_
19. In diphtheria a grayish \_\_\_\_\_ is formed over pharynx
20. The toxin produced by *Sh. dysenteriae* is called \_\_\_\_\_
21. The site of *Shigella* infection is \_\_\_\_\_ in the Peyer's patches.
22. Bacillary dysentery spreads by the \_\_\_\_\_ route.
23. The bacillary dysentery stool mainly consists of \_\_\_\_\_.
24. *Shigella flexneri* causes \_\_\_\_\_ in man
25. The toxin produced by cholera is \_\_\_\_\_
26. Two biotypes of *V. cholerae* are \_\_\_\_\_
27. The cholera toxin consists of \_\_\_\_\_ and \_\_\_\_\_ subunits
28. Cholera stool specimens are collected and inoculated into \_\_\_\_\_ water
29. The flagellar antigen are \_\_\_\_\_ antigens
30. Oxygen labile toxin of *Cl. tetani* is called \_\_\_\_\_
31. The neuro toxin of *Cl. tetani* is known as \_\_\_\_\_
32. The release of \_\_\_\_\_ is prevented by tetanus toxin
33. The stiffness of Jaw seen in tetanus is called \_\_\_\_\_.
34. The tetanus bacilli with spores give the appearance of \_\_\_\_\_.

35. *C. botulinum* causes the disease \_\_\_\_\_
36. *C. botulinum* produces \_\_\_\_\_ type of toxin.
37. Among the 7 botulinum toxins, \_\_\_\_\_ are the important ones.
38. *C. botulinum* produces a potent \_\_\_\_\_ in food.
39. Botulinum toxin produces \_\_\_\_\_ paralysis.
40. Chlamydiae are obligate \_\_\_\_\_ bacteria
41. As Chlamydiae have limited metabolic capacity they are called \_\_\_\_\_ parasites
42. Chlamydial inclusions are seen in \_\_\_\_\_
43. Chlamydia replicates within \_\_\_\_\_ of the host cell.
44. The infectious particle of *C. trachomatis* is called \_\_\_\_\_.
45. Chlamydia divides repeatedly by \_\_\_\_\_.

### Part II (Very short answers -- Two marks questions)

1. State the nature and action of endotoxin
2. State the characteristics of resident flora
3. Give characteristics of transient flora
4. How does normal flora compete with pathogens
5. What will be the result of interaction between parasites and hosts?
6. What is alpha haemolysis? Give examples of organisms producing it
7. What is beta haemolysis? Give examples of organisms producing it.
8. What are the sources of infection of *Staphylococcus aureus*?

9. What is the action of exfoliative toxin?
10. Which is the important test to identify *S.aureus*? Explain in two sentences
11. Why repeated episodes of *Str.pyogenes* infection increase the severity of rheumatic fever?
12. Explain the properties of M proteins
13. Explain the properties of M like protein
14. Describe the haemolytic activity of *Str.pyogenes*
15. What is gamma haemolysis? Give examples of organisms producing it.
16. Describe the characteristics of *C.diphtheriae*.
17. Describe the growth characteristics of *C.diphtheriae*.
18. State the composition of pseudomembrane.
19. State the characteristics of pseudomembrane seen in diphtheria.
20. Give the characteristics of *Salmonella*.
21. What are the four species of genus *Shigella*? On what basis they are divided?
22. Which is the solid medium used for the growth of vibrios? How do the colonies appear?
23. Describe vibrios.
24. Give the structure of tetanus bacilli
25. Where are the tetanus spores found?
26. How is passive immunization done for tetanus?
27. Describe the characteristics of *C.botulinum* spores.
28. State the morphological characteristics of *C. botulinum*.
29. Give a list of diseases produced by *Chlamydia trachomatis*

30. Give a list of diseases produced by *Chlamydia psittaci*
31. State the characteristics of Elementary body of *Chlamydiae*.
32. Tabulate the immunotypes of *Chlamydiae*.

### Part III -- Short answers -- Five marks questions

1. Describe the properties of capsule
2. Describe the properties of adhesins
3. What all the factors that contribute to bacterial virulence?
4. Describe the characteristics of vaginal flora
5. Explain the role of normal flora with example
6. What are the different types of infections produced by *Staphylococci*?
7. What are the specimens collected for the diagnosis of *Staphylococcal* infections?
8. Write short notes on the treatment of *Staphylococcal* infections
9. List and explain the characteristics of enzymes of *str.pyogenes*
10. Describe invasive soft tissue infections due to *Str.pyogenes*
11. Describe AGN and its mechanism of pathogenesis.
12. Describe the pathogenesis of Diphtheria
13. Describe the pathological features observed in diphtheria
14. Describe the Clinical manifestations of diphtheria
15. What are the different clinical syndromes produced by *Salmonella*?
16. What are the clinical features of bacillary dysentery?
17. Write short notes on shiga toxin.
18. Write briefly about laboratory diagnosis of bacillary dysentery.

19. Write short notes on general characters of vibrio.
20. What are the clinical manifestations of cholera?
21. How is *V. cholerae* diagnosed in the laboratory?
22. Write in short about the treatment of cholera.
23. Describe the clinical features of tetanus
24. Explain the laboratory diagnosis of tetanus
25. Give an account of treatment of tetanus
26. Describe the toxins of *C. botulinum*
27. Describe the clinical features of Botulism
28. How is botulism diagnosed in the laboratory.
29. Describe the reproduction in Chlamydia
30. Describe the characteristics of different antigens of Chlamydia
31. Describe the characteristics of inclusions of chlamydiae

**Part IV (Essay Type -- Ten marks questions)**

1. Explain nontoxic determinants of bacterial virulence
2. Describe the mechanisms by which bacteria enter the human body to cause disease.
3. Describe normal microbial flora of human body and their role .
4. List the toxins and enzymes produced by *S.aureus* and explain their actions.
5. Give the details of the infections produced by *Staphylococcus aureus* and their symptoms.
6. Describe invasive soft tissue infections due to *Str.pyogenes*.
7. Describe post streptococcal sequelae and their mechanism of pathogenesis.

8. Describe in detail the prophylaxis of diphtheria
9. Write in detail about the clinical features and pathogenesis of bacillary dysentery.
10. Discuss the source, spread and control of Bacillary dysentery.
11. Write in detail about pathogenesis, structure and function of cholera toxin.
12. Give a detail account of tetanus toxin and its mechanism of action
13. Describe the epidemiology, prevention and control of tetanus
14. Explain different types of botulism with clinical features.
15. List the differences between elementary and reticulate body
16. Describe the etiology, pathogenesis and laboratory diagnosis of Trachoma
17. Describe the laboratory diagnosis of *Mycoplasma*.

**Section - IV**  
**PARASITOLOGY, MYCOLOGY,**  
**VIROLOGY & ZOONOTIC DISEASES**  
**Evaluation**  
**Part I (Objective types)**

**Division A : Choose the best answer:**

1. Kala Azar is caused by
  - a. Trypanosoma brucei.
  - b. Leishmania donovani.
  - c. Bacteroides melaninogenicus.
  - d. Listeria monocytogenes
2. L. donovani was first cultivated by
  - a. Rogers.
  - b. Leishman.
  - c. Donovan.
  - d. Robert Koch.
3. L. donovani is transmitted by
  - a. Ticks.
  - b. Sand fly.
  - c. Mosquitoes.
  - d. Rat Flea.
4. T. brucei gambiensi is present in which place?
  - a. Eastern India.
  - b. South India.
  - c. West Africa.
  - d. All the above.
5. T. brucei rhodesiense is present in which place?
  - a. Middle East.
  - b. South east Asia.
  - c. East Africa.
  - d. South America.
6. In which part of the world T. cruzi is present?
  - a. Australia.
  - b. South Africa.
  - c. South America.
  - d. South India.
7. When the sexually mature adults are present in a host, that host is called
  - a. Intermediate host.
  - b. Definitive host.
  - c. Paratenic host.
  - d. Normal host.

8. Which of the following is the habitat of adult *F. hepatica*.

- a. Lungs.
- b. Intestine.
- c. Liver
- d. Brain.

9. *T. solium* is otherwise called

- a. Beef tape worm.
- b. Pork tape worm.
- c. Round worm.
- d. None of the above.

10. A tape worm segment is called

- a. Proglottid.
- b. Epiglottis
- c. Both.
- d. None of these.

11. The head of tapeworm is otherwise called

- a. Scolex.
- b. Proglottid
- c. Brain
- d. All the above.

12. The adult tape worm lives in the human

- a. Small intestine.
- b. Large intestine
- c. Rectum
- d. All the above.

13. The worms can live upto

- a. 25 seconds.
- b. 25 minutes.
- c. 25 days.
- d. 25 years.

14. *Candida* is:

- a. An yeast
- b. Yeast like fungus
- c. Mould
- d. Bacteria

15. *Candida albicans* produces:

- a. Spores
- b. Capsule
- c. Pseudomycelium
- d. All the above

16. Candida stains:
- Gram positive
  - Gram negative
  - Gram variable
  - Acid fast
17. Cryptococcus is a -
- Non – capsulated yeast cell.
  - Capsulated yeast cell
  - Mucous coated yeast cell.
  - Uncovered yeast cell.
18. Cryptococcosis is seen in –
- Tuberculosis patients.
  - Fever patients.
  - AIDS patients
  - No patients.
19. The mycetoma causing agents are of
- 4 types
  - 2 types
  - 3 types
  - 5 types
20. Meacetoma causing agents enter through
- mouth
  - nose
  - eye
  - minor trauma on the skin

21. The genome of Herpes virus is made up of
- SS DNA
  - SS RNA
  - DS DNA
  - DS RNA
22. Herpes viruses with a short replicating cycle and fast growth are classified as
- Beta Herpes virus
  - Alpha Herpes virus
  - Fast viruses
  - Gamma Herpes virus
23. Genital herpes is caused by
- HIV-1
  - HSV-1
  - HSV-2
  - HIV-2
24. Herpes fibrilis or fever blisters in fever patients is due to
- Primary infection
  - Viral replication
  - Viral reactivation
  - None of the above
25. Multinucleated giant cells seen in Herpes virus infections are called as
- Tzanck cells
  - Cancer cells
  - Clue cells
  - All the above
26. Hepatitis A virus belongs to the family
- Picornaviridae
  - Caliciviridae
  - Retroviridae
  - Hepadnaviridae
27. Hepatitis A and E are transmitted via
- Sexual contact
  - Needle stick
  - Feco-oral route
  - Animal bite.

28. Hepatitis B virus belongs to the family
- Picornaviridae
  - Caliciviridae
  - Retroviridae
  - Hepadnaviridae
29. HIV belongs to the family
- Caliciviridae
  - Flaviviridae
  - Retroviridae
  - Reoviridae
30. The genetic material of HIV is
- double stranded DNA
  - Single stranded DNA
  - Double stranded RNA
  - Single stranded RNA
31. HIV attaches to the CD4 receptor of
- T-helper lymphocytes
  - Platelets
  - B cells
  - RBC
32. By which of the following methods AIDS is not spread
- Blood transfusion
  - Sharing of needles
  - Shaking hands with infected persons
  - Sexual contact with infected persons.
33. Brucella organisms are
- Gram negative bacilli
  - Gram negative cocci
  - Gram positive bacilli
  - Gram positive cocci.
34. Brucella species causes
- Typhoid fever
  - Undulant fever
  - Rat bite fever
  - Viral fever
35. The name given to brucellosis in early days was
- Malta fever
  - undulant fever
  - Typhoid fever
  - Rat bite fever
36. Lyme disease is caused by
- Borrelia burgdorferi.
  - Leptospira interrogans.
  - Chlamydia psittacii.
  - All the above.
37. Lyme disease is transmitted by the bite of
- Sand fly.
  - Ticks.
  - Mosquitoes.
  - Culex mosquitoes.
38. Borrelia burgdorferi is cultivated in
- EMJH Medium.
  - BHI broth.
  - BSK medium
  - NNN medium.
39. In Lyme disease, a red macule or papule that expands to form a large annular lesion called
- Psoriasis.
  - Erythema migrans
  - Migraine.
  - Larva migrans.



40. In Lyme disease meningoencephalitis, myocarditis and chronic arthritis are seen in
- a. Untreated individuals.      b. Initial stages of infection.  
c. Treated individuals      d. All the above.

**Division B : Fill in the blanks**

1. *L. donovani* is present as \_\_\_\_\_ form in vertebrate host.
2. \_\_\_\_\_ medium is used in the cultivation of *L. donovani*.
3. *L. donovani* was first discovered in the year \_\_\_\_\_
4. *T. brucei gambiense* is endemic in \_\_\_\_\_
5. *T. brucei rhodesiense* kills its victim in \_\_\_\_\_
6. The reservoir of *T. brucei rhodesiense* [Rhodesian trypanosomiasis] is \_\_\_\_\_
7. Larval stages may survive but do not develop in \_\_\_\_\_ host.
8. Intermediate hosts are those in which one or more \_\_\_\_\_ as necessary part of the life cycle.
9. *F. hepatica* inhabits \_\_\_\_\_.
10. Taeniasis is caused by two important species, *Taenia* \_\_\_\_\_ and *Taenia* \_\_\_\_\_
11. Specialised structures called \_\_\_\_\_ anchor the tape worm to the host's intestinal wall.
12. Indirect \_\_\_\_\_ test is used as a serodiagnostic test for taeniasis.

13. Eradication of *Taenia* infection in humans is achieved by \_\_\_\_\_ and \_\_\_\_\_
14. \_\_\_\_\_ can be concentrated from the stool by both sedimentation and floatation techniques.
15. *Candida albicans* produces thick walled \_\_\_\_\_ below 26°C
16. Infection of the oral cavity by *C. albicans* is called \_\_\_\_\_
17. *C. albicans* produces curved elongated \_\_\_\_\_ in mammalian serum
18. The *Cryptococcus* capsule is made up of \_\_\_\_\_.
19. The disease caused by *Cryptococcus* is generally known as \_\_\_\_\_.
20. The main form of cryptococcal disease is \_\_\_\_\_
21. The specimen collected for meningitis is \_\_\_\_\_
22. Mycetoma opens out through \_\_\_\_\_
23. Eumycotic filaments are Gram \_\_\_\_\_
24. Herpes viruses multiply inside the \_\_\_\_\_ of the infected cells.
25. Herpes simplex viruses establish latent infection in \_\_\_\_\_.
26. Beta Herpes virus causes latent infection of \_\_\_\_\_.
27. The shape of Herpes viruses is \_\_\_\_\_.
28. Cytomegaly is produced by \_\_\_\_\_.

29. The genetic material of Hepatitis A virus is \_\_\_\_\_.
30. The genetic material of Hepatitis B virus is \_\_\_\_\_.
31. HBV is also known as \_\_\_\_\_.
32. Delta agent requires \_\_\_\_\_ for its replication.
33. HIV belongs to the subfamily \_\_\_\_\_.
34. The nucleocapsid of HIV has an outer \_\_\_\_\_.
35. The external envelope glycoprotein of HIV is \_\_\_\_\_.
36. The typical course of HIV infection spans about \_\_\_\_\_ years.
37. The CD4 T cell count decreases to \_\_\_\_\_ before full blown AIDS develops.
38. Brucellosis is a \_\_\_\_\_ disease.
39. Brucella infection in pregnant animals leads to \_\_\_\_\_.
40. Human beings get Brucella infection from \_\_\_\_\_.
41. Brucella organism appears like \_\_\_\_\_.
42. Brucella infected milk is safe for use after \_\_\_\_\_.
43. Brucella was first isolated by \_\_\_\_\_.
44. Lyme disease is named after the town \_\_\_\_\_ in Connecticut, USA.
45. \_\_\_\_\_ occurs at the site of tick bite.
46. Symptoms suggestive of meningeal irritation may occur in \_\_\_\_\_ stage of lyme disease.
47. \_\_\_\_\_ and \_\_\_\_\_ are done to demonstrate B.burgdorferi for laboratory diagnosis.

### Division C : Match the following

- |                                 |   |                             |
|---------------------------------|---|-----------------------------|
| 1. <i>T. brucei gambiense</i>   | - | a. Reduvid bug.             |
| 2. <i>T. cruzi</i>              | - | b. Sand fly.                |
| 3. <i>L. donovani</i>           | _ | c. Antelope.                |
| 4. <i>T. brucei rhodesiense</i> | - | d. <i>Glossina palpalis</i> |
|                                 |   | e. <i>Aedes aegypti</i> .   |

### Part II -- ( Very short answers - Two markquestions)

1. Describe the geographical distribution of Leishmaniasis.
2. Write a note on LD body.
3. Describe the ultrastructure of a Promastigote.
4. State the characteristics of tsetse fly.
5. List the measures adopted for the control of trypanosomiasis.
6. What happens to *T. cruzi* in reduvid bug ?
7. What is direct life cycle ?
8. What is indirect life cycle ?
9. Give the characteristics of *F. hepatica* egg.
10. What are the causative agents of Taeniasis?
11. Describe the structure of *Taenia solium*.
12. What are the clinical manifestations seen in Taeniasis.

13. Define Cysticercosis.
14. What is the treatment for human taeniasis ?
15. Which characteristics of *C.albicans* differentiate it from other candida species?
16. Where is *Candida albicans* present in the body? When does it cause an infection?
17. Describe *C. neoformans* shortly.
18. Describe the cryptococcal clinical manifestations.
19. What are the 4 methods of identification of Cryptococcal meningitis ?
20. Name the true fungi which cause mycetoma .
21. Name actinomycotic agents which cause mycetoma.
22. How mycetoma is treated?
23. What are Alpha herpes viruses? Give examples.
24. What are Beta herpes viruses? Give examples.
25. What are the types of HSV?
26. Write short notes on Hepatitis D virus.
27. Write short notes on HGV.
28. What are the modes of transmission of HIV?
29. What are the modes through which HIV is not spread?
30. How do brucella bacilli enter the blood stream?

31. Describe brucella organisms shortly.
32. Explain the species of *Brucella* and their animals.
33. What is lyme borreliosis ?
34. List the animal reservoirs of *Borrelia*.
35. What are the specimens collected for lyme disease ?
36. What are the treatment and prophylaxis for lyme disease ?
37. List the vectors of lyme disease.

**Part III : (Short answers - Five Mark questions)**

1. Describe the Life cycle of *Leishmania donovani*
2. Describe in detail the pathogenecity and clinincal manifestations of Leishmaniasis.
3. Describe the life cycle and transmission of *T. brucei gambiense*.
4. Describe the life cyle of *T. brucei rhodesiense*.
5. Describe the morphology and life cyle of *T. cruzi*.
6. Describe the laboratory diagnosis of Chaga's disease.
7. Describe the characteristics of Trematodes.
8. Describe the characteristics of Cestodes.
9. Describe the laboratory diagnosis of *F. hepatica* infection.
10. Describe the Life cycle and transmission of *Taenia solium*.
11. Explain the laboratory diagnosis and control measures of human taeniasis.

12. Describe the structure of *C. albicans* and its special forms.
13. What is the treatment and prevention of candida infections
14. Describe the pathogenesis of cryptococcosis.
15. Explain the treatment given in cryptococcal meningitis.
16. Give at least five points to differentiate Eumycetes from Actino mycetes which cause mycetoma.
17. What are the specimens collected for the diagnosis of mycetoma and how are they transported?
18. Write about the structure and classification of Herpes viruses.
19. Write a short note on Herpes virus replication.
20. Tabulate the important characteristics of hepatitis viruses.
21. Write short notes on Hepatitis C virus.
22. Write about the structure and classification of HIV.
23. What are the secondary infectious diseases in AIDS?
24. Write about the replication of HIV.
25. Explain the pathogenesis of brucellosis.
26. Give an account of brucella organisms and brucellosis.
27. Write a short note on Borrelia
28. How will you diagnose lyme disease in the laboratory ?

#### **Part IV - (Essay type - Ten Mark questions)**

1. Elaborate on the Laboratory diagnosis of Leishmaniasis.
2. Describe the life cycle of *T. cruzi* and the clinical aspects of the disease produced by it.
3. Describe the characteristics, life cycle and transmission of *F. hepatica*.
4. Describe in detail the general features, life cycle, treatment and laboratory diagnosis and control measures of human taeniasis.
5. Describe in detail the pathogenesis and laboratory diagnosis of candidiasis
6. Explain in detail about the laboratory diagnosis of Cryptococcosis.
7. Discuss in detail the direct examination of mycetoma granules, their morphology with diagrams.
8. Write in detail the pathogenesis of HSV.
9. Clinical manifestation of HSV infection.
10. Laboratory diagnosis of HSV.
11. Write in detail about Hepatitis A virus.
12. Write about Hepatitis E virus.
13. Write in detail about Hepatitis B virus.
14. Write about the clinical manifestations of HIV infection.
15. What are the preventive measures for HIV infection?
16. Explain the laboratory diagnosis and serology of brucellosis.
17. Explain in detail the epidemiology prevention and control of brucellosis
18. Write about the pathogenecity and clinical manifestations of lyme disease.

**Section - V**  
**IMMUNOLOGY**  
**Evaluation**  
**Part I (Objective types)**

**Division A : Choose the best answer:**

1. Thymus is located in which part of the body?
  - a. Respiratory tract.
  - b. Thoracic cavity
  - c. Abdomen.
  - d. Intestinal tract.
2. "Nurse cells" are present in which organ?
  - a. Skin.
  - b. Intestine.
  - c. Liver.
  - d. Thymus.
3. Which of the following happens during maturation of T cells in thymus?
  - a. Change in size of cell.
  - b. Change in differentiation markers.
  - c. Staining characteristics.
  - d. All of the above.
4. Exogenous antigen presentation is associated with which of the following MHC molecules?
  - a. MHC I
  - b. MHC II
  - c. MHC III
  - d. All the above.
5. Endogenous antigen presentation is associated with which of the following MHC molecules?
  - a. MHC I
  - b. MHC II
  - c. MHC III
  - d. All the above.
6. How many different types of heavy chains are seen in immunoglobulins?
  - a. Two.
  - b. Three.
  - c. Four.
  - d. Five.
7. How many types of light immunoglobulin chains are seen?
  - a. Two.
  - b. Three.
  - c. Four.
  - d. Five.
8. Which antibody appears first after a primary infection?
  - a. IgA.
  - b. IgG
  - c. IgM.
  - d. All the above.
9. In the direct immunofluorescence test which of the following is labelled with fluorochromes?
  - a. Antigen.
  - b. Specific antibody to antigen
  - c. Antibody to immunoglobulin.
  - d. All the above.

10. In the indirect immunofluorescence test, which of the following is labelled with fluorochromes?
- Specific antibody to antigen.
  - Antibody to immunoglobulin.
  - Antigen.
  - All the above.
11. For labelling antibody for immunofluorescence test, which of the following is used?
- Fluorescein.
  - Fluorescence Isothiocyanate.
  - Fluorescence Carbamide.
  - All the above.
12. Which of the following is a live vaccine?
- TAB.                                      b. Pertussis.
  - BCG                                         d. All the above.
13. Which of the following is a killed vaccine?
- TAB vaccine.                                b. Pertussis vaccine.
  - Phenolised Cholera vaccine.         d. All the above.
14. Which of the toxoids is used routinely for immunization?
- Diphtheria toxoid.                        b. Cholera toxoid.
  - E. coli toxoid.                              d. Pertussis toxoid.

15. There are \_\_\_\_\_ types of immediate hypersensitivity reactions.
2.    b. 3.    c. 4    d. 5.
16. Type I hypersensitivity reaction is \_\_\_\_\_ mediated.
- IgE    b. IgM.
  - IgG    d. IgA.
17. Blood transfusion reaction comes under
- Type I reaction.                              b. Type II reaction.
  - Type III reaction.                            d. Type IV reaction.

**Division B : Fill in the blanks**

- Thymus in mammals is a \_\_\_\_\_ organ.
- Immature pre-thymic cells from \_\_\_\_\_ come to cortex of thymus.
- Cortical thymocytes are less \_\_\_\_\_ than medullary thymocytes.
- Mature T cells leave the thymus via \_\_\_\_\_ located at cortico-medullary junction.
- Post capillary venules are located at \_\_\_\_\_ junction in thymus.
- The T cells change their \_\_\_\_\_ during maturation.
- The ectoderm of \_\_\_\_\_ forms thymic cortex.
- The endoderm of \_\_\_\_\_ differentiates into thymic medulla.

9. Flagella are more \_\_\_\_\_ than polyrised flagellin.
10. Increasing complexity contributes to molecules' \_\_\_\_\_
11. Very small dose of antigen may induce \_\_\_\_\_
12. Very high dose of antigen may induce \_\_\_\_\_
13. Antigenic determining site of an antigen is called \_\_\_\_\_
14. Dendritic cells develop into \_\_\_\_\_ cells in the tissues.
15. IgA is present predominantly in \_\_\_\_\_
16. IgE antibody is raised during \_\_\_\_\_ responses.
17. C terminus of light chain contains \_\_\_\_\_ region.
18. N terminus of light chain contains \_\_\_\_\_ region.
19. Typhoid [TAB] vaccine contains \_\_\_\_\_ organisms.
20. BCG contains \_\_\_\_\_ organisms.
21. CMI is induced more efficiently with \_\_\_\_\_ vaccine.
22. Immunity lasts for several years when immunized with \_\_\_\_\_ vaccine.
23. The harmful reaction of immune system is \_\_\_\_\_
24. Type III hypersensitivity is \_\_\_\_\_ mediated.
25. Delayed type hypersensitivity is \_\_\_\_\_ mediated.
26. Hemolytic disease of the new born is \_\_\_\_\_
27. Glomerulonephritis is a well known \_\_\_\_\_ disease.

## Part II -- ( Very short answers - Two markquestions)

1. List the types of epithelial cells present in thymus.
2. What signals attract stem cells to migrate to thymus?
3. Define an antigen.
4. State the role of dose of antigen and its immunogenic capacity.
5. Define an epitope.
6. Define Antibody.
7. List the major classes of antibodies.
8. Explain the formula for antibody.
9. State the beneficial role of IgE.
10. Define Fluorescence.
11. Give a list of fluorochromes used in immunology.
12. Name two enzymes used in ELISA test.
13. What is hypersensitivity?
14. Classify hypersensitivity reactions.
15. Explain the mechanism of pathogenesis of type II reaction.
16. What is Erythroblastosis Foetalis ?
17. Explain Type IV reaction.
18. Give the ways by which one can prevent infectious disease.
19. Define Immunization.

20. Define Active Immunization.
21. Define Passive Immunization.
22. Give a list of live attenuated vaccine.
23. State the advantages and disadvantages of vaccines.
24. What is toxoid? State its characteristics.

**Part III : (Short answers - Five Mark questions)**

1. With neat diagram describe the structure of thymus and label the various parts.
2. Describe the sequential changes that occur during T cell maturation.
3. Describe the development of antigen presenting cells.
4. Describe the structure of heavy chain of immunoglobulin molecule.
5. Describe the structure of light chain of immunoglobulin molecule.
6. Give the characteristics of IgG1.
7. Give the characteristics of IgG2.
8. Give the characteristics of IgG3.
9. Give the characteristics of IgG4.
10. Give the characteristics of IgM molecule.
11. Describe IgA and its function.
12. Compare direct and indirect immunofluorescence tests.
13. What are the differences between immediate and delayed type hypersensitivity reactions.
14. Explain the mechanism of anaphylaxis with diagram.
15. Explain Arthus reaction.
16. Explain tuberculin type reaction with its mechanism.
17. Describe the characteristics of TAB vaccine.
18. Describe the characteristics of BCG vaccine.
19. Describe the advantages and disadvantages of live and killed vaccines.
20. Describe the passive immunization for bacterial diseases.
21. Describe the passive immunization for viral diseases.
22. Compare the characteristics of live & killed vaccines.
23. Describe the method by which attenuation is carried out.

**Part IV - (Essay type - Ten Mark questions)**

1. Describe the development of T cells in thymus.
2. Describe the requirements for immunogenicity of an antigen.
3. List & describe the characteristics of antigen presenting cells.
4. Describe exogenous antigen presentation.
5. Describe endogenous antigen presentation.
6. Describe the structural characteristics of antibody molecule.



7. Give the properties of Fluorochromes to be used for labelling antibodies.
8. Explain direct method of immunofluorescence method.
9. Explain indirect immunofluorescence.
10. Describe in detail the techniques and uses of ELISA test.
11. Discuss in detail Type I hypersensitivity reactions.
12. Define Type II hypersensitivity reactions, their mechanism and clinical features.
13. Define delayed type hypersensitivity, classify and explain its mechanism in detail.
14. Write an essay on vaccines.

**Section - VI**  
**MICROBIAL GENETICS**  
**Evaluation**  
**Part I (Objective types)**

**Division A : Choose the best answer:**

1. Which of the following persons solved the structure of DNA ?  
(a) Ames (b) Watson and Crick.  
(c) Nirenberg-Khorana (d) Herbert Boyer.
2. The genetic code consists of how many codons ?  
(a) 64 (b) 32 (c) 128 (d) 16
3. A codon consists of how many nucleotides ?  
(a) 2 (b) 3 (c) 4 (d) 1
4. The codons were discovered by which of the following scientists ?  
(a) Marshall Nirenberg (b) Har Gobind Khorana  
(c) Philip Leader (d) All the above
5. Which of the following is a stop codon ?  
(a) UGA (b) GCU (c) CAG (d) AAG
6. How many sense codons are present in the genetic code ?  
(a) 64 (b) 61 (c) 60 (d) 20
7. Which of the following is involved in pyrimidine dimer repair ?  
(a) Mismatch repair (b) Photoreactivation  
(c) Excision repair (d) All the above.

**Division B : Fill in the blanks :**

1. The base sequence and the structure of DNA was solved by \_\_\_\_\_.
2. The genetic code consists of \_\_\_\_\_ codons.
3. A condon consists of \_\_\_\_\_ nucleotides.
4. The codons are written \_\_\_\_\_ as appear in the mRNA.
5. Three nucleotides code for \_\_\_\_\_ amino acid in a protein.
6. The correct reading frame is set by the \_\_\_\_\_ codon.
7. Change in nucleotide sequence from the parental DNA is called \_\_\_\_\_.
8. The agents that cause mutation are called \_\_\_\_\_.
9. Point mutation affects \_\_\_\_\_ in DNA.
10. Many known mutagens are \_\_\_\_\_.
11. Removal of bases in DNA is catalysed by \_\_\_\_\_.
12. Transfer of DNA from one bacterium to another carried out by phage is known as \_\_\_\_\_
13. In bacteria lytic cycle is induced by \_\_\_\_\_ phage.
14. Plasmids are \_\_\_\_\_ DNA molecules.
15. Two DNA fragments are joined together by \_\_\_\_\_.

**Division C : Match the following :**

- |                        |                         |
|------------------------|-------------------------|
| 1. Bacterio phage      | A. Palindromic sequence |
| 2. Plasmids            | B. Photo reactivation   |
| 3. Pyrimidine dimer    | C. Excision repair      |
| 4. Uracil glycosylase  | D. Conjugation          |
| 5. Restriction enzymes | E. Transduction         |
|                        | F. Ligation             |

**Part II**

(Very short answers - 2 mark questions)

1. Why a codon should have at least three nucleotides?
2. Define a gene.
3. What is a mutagen?
4. What is an auxotroph?
5. Define mutation.
6. What is a prototroph?
7. Define transition mutation.
8. Define transversion mutation.
9. What is a forward mutation?
10. Define a wild type.
11. Which organism is used for Ames test?
12. What is photo reactivation?
13. Define a genotype.
14. Define a phenotype
15. What is code degeneracy ?
16. State Watson - Crick rule.
17. What is Wobble hypothesis ?
18. List the type of alterations that can occur in the nucleotide sequences of DNA.
19. List general mechanisms of DNA repair.
20. Define lysogeny.

21. State the significance of Transduction.
22. What is palindromic sequence ? Give an example.

### **Part III**

(Short answers - 5 mark questions)

1. What is an Hfr cell?
2. What is a genetic code?
3. Name the three ways by which genetic exchange occurs in bacteria.
4. Describe the principle of the Ames test for identifying chemical carcinogens.
5. Describe the methods of detection of mutations.
6. Describe the phenotypic effects of mutants.
7. Describe the technique of isolation of mutants.
8. Describe excision repair mechanisms.
9. Describe Transduction.
10. Describe conjugation in bacteria.
11. With example, describe restriction enzyme and its action.
12. Define and state the properties of a cloning vector.
13. Describe Ti plasmid with diagram.
14. Describe the production and properties of plant protoplasts.

### **Part IV**

(Essay type - 10 mark questions)

1. Explain the three ways by which genetic exchange occurs in bacteria.
2. Describe the principle of the Ames test for identifying chemical carcinogens.
3. Describe the methods of animal cell culture.
4. Describe the production of Transgenic animals.
5. Describe the methods of gene transfer in plants.

## SECTION - VI

### Chapter - 10

## MICROBIAL GENETICS GENETIC CODE

The base sequence and the structure of DNA was solved by Watson and Crick in 1953. However, how the base sequence of DNA specifies the amino acid sequence of proteins remained elusive for another 10 years.

The question is: How many nucleotides are necessary to specify a simple amino acid?

		Second base				
		U	C	A	G	
U	UUU	UCU	UAU	UGU	U C A G	
	UUC	UCC	UAC	UGC		
	UUA	UCA	UAA	UGA		
	UUG	UCG	UAG	UGG		
C	CUU	CCU	CAU	CGU	U C A G	
	CUC	CCC	CAC	CGC		
	CUA	CCA	CAA	CGA		
	CUG	CCG	CAG	CGG		
A	AUU	ACU	AAU	AGU	U C A G	
	AUC	ACC	AAC	AGC		
	AUA	ACA	AAA	AGA		
	AUG	ACG	AAG	AGG		
G	GUU	GCU	GAU	GGU	U C A G	
	GUC	GCC	GAC	GGC		
	GUA	GCA	GAA	GGA		
	GUG	GCG	GAG	GGG		

**Fig.10-1** The genetic code consists of 64 codons. The codons are written 5' → 3' as appear in the mRNA.

The basic unit of the genetic code, the set of bases that encodes a single amino acid is a codon. Each nucleotide portion in mRNA can be occupied by one of four bases. A,G,C or U. If a codon consisted of a single nucleotide, only four different codons would be possible, which is not sufficient for the 20 different amino acids found in protein.

If codons are of two nucleotide each, such as UG, AC, GC etc, there would be  $4 \times 4 = 16$  possible codons. Even then it is not enough to code for 20 amino acids. Three nucleotides per codon may have  $4 \times 4 \times 4 = 64$  possible codons and can encode all 20 amino acids. The genetic code is a triplet code, in which three nucleotides code for each amino acid in a protein.

The codons were discovered in the early 1960's by Marshall Nirenberg, Heinrich Mathaei, Philip Leader and Har Gobind Khorana. The Genetic code in RNA form is summarized above.

If you analyze the chart, you may find that there are upto six different codons for a given amino acid. It is called Code degeneracy.

There are three codons UGA, UAG and UAA, involved in the termination of translation and are called Stop or nonsense codons. So the remaining 61 codons are called sense codons. Many codons differ only in the third position. For example, the codons GCU, GCC, GCA and GCG all of which begin with GC encodes the amino acid alanine.

The codon on the mRNA and the anticodon on the tRNA join during translation. The first two bases strictly follow the Watson and Crick rules. i.e., A with U; C with G, where as the third bases pair weakly. There may be flexibility. This process is called Wobble hypothesis.

Each sequence of nucleotides possesses three potential reading frames. The correct reading frame is set by the initiation codon. The initiation codon is usually AUG. The GUG and UUG are used in rare occasions. Three codons UAA, UAG and UGA do not code for any aminoacids. These codons signal the end of the protein in prokaryotes and eukaryotes. They are called as Stop codons, Termination codons or nonsense codons.

It was believed that genetic code is universal, meaning that each codon specifies the same amino acid in all organisms. Now it has been known that genetic code is not universal; a few exceptions have been found. Most of the exceptions are termination codons, but there are few cases in which one sense codon substitutes for another. The exceptions are mostly found in mitochondrial genes. A few non universal codons have also been found in nuclear genes of protozoans and in bacterial DNA.

### Mutation and its effect

The hydrogen bonded helical structure of DNA gives an extraordinary degree of stability to the structure of DNA molecule. Alterations on the DNA molecule reflected in a concomitant change in some properties of the cell. The alteration in the DNA molecule means a change in nucleotide sequence from the parental DNA is called mutation. Mutations can be defined as a heritable change in the sequence of nucleotides of DNA. Mutations may account for evolutionary changes in microorganisms.

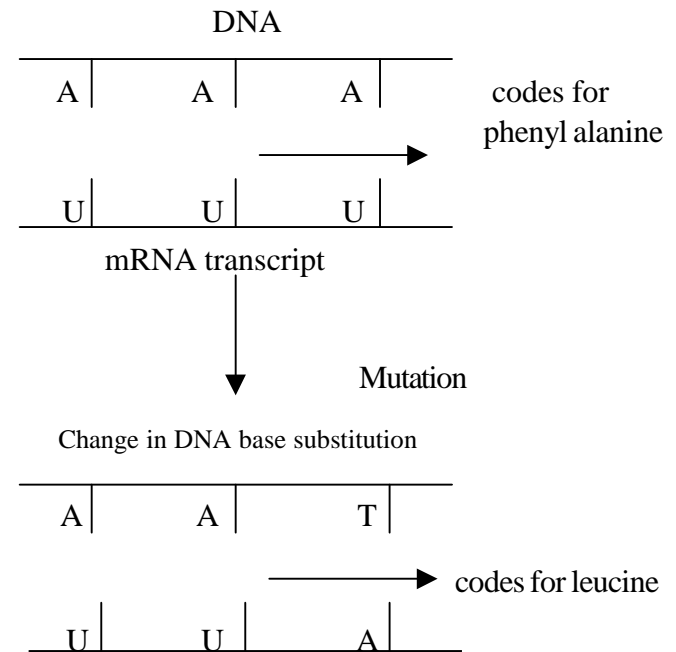
The organism's genotype refers to the genetic information contained in the DNA of the organism and the phenotype refers to the specific characteristics displayed by the organisms. Mutations alter the genotype of the organism and this may or may not be expressed in the phenotype depending on the nature of the mutation. Mutations may occur spontaneously or may be induced by agents. The agents that cause mutation are called mutagens. Spontaneous mutation frequencies are generally low and occur with a probability from  $10^{-7}$  to  $10^{-12}$  per generation. Induced mutation occurs at a higher frequency. In general there are 4 types of alterations which can occur in the nucleotide sequence of DNA.

1. Deletions, the loss of one or more nucleotides.
2. Addition, the acquisition of one or more nucleotides.
3. Transversions, the substitution of a purine for a pyrimidine and vice versa.
4. Transitions, purine-purine or pyrimidine-pyrimidine substitutions.

### Types of mutation and its effect:

The mutations can be divided into 1. Point mutation. 2. Frame shift mutation.

Point mutation affects a single base whereas frame shift mutation can affect more than one base in DNA. Point mutation involves base substitution or nucleotide replacement with which one base is substituted for another and a specific location in a gene. For example: a three base sequence of DNA is changed from AAA to AAT, during transcription the mRNA codon will change from UUU to UUA. When the information in the mRNA is used to synthesise the protein the amino acid leucine will be substituted for phenylalanine in the protein.[figure 10-2]



**Fig.10-2** Effect of mutation on change in amino acid sequence

In frame shift mutation there will be a deletion or insertion of one or more bases resulting in altered codon reading frame. Mutants can be classified based on the method of detection.

1. Morphological mutants: They have altered external form including size, shape, colour etc. eg: kernel colouring in corn, curled wing in *Drosophila*.
2. Lethal mutants : They have a change in the genotype that may lead to the death of an individual.
3. Biochemical mutants, or Auxotrophic mutants. They are deficient in synthesizing a particular chemical compound.
4. Resistant mutants : They are identified by their ability to grow in the presence of antibiotics.
5. Conditional mutants: They allow the mutant phenotype to be expressed only under certain conditions. Eg: high salt content (called restrictive mutants).

### Phenotypic effects of mutants

Mutants have a variety of phenotypic effects. The most common phenotype in natural populations of an organism is called wild type phenotype. A change from the wild type by genetic variation in the nucleotide sequence results in phenotypic variation which is called a mutant. A mutation that alters the wild type phenotype is called a forward mutation; where as a reverse mutation (a reversion) changes the mutant phenotype back into the wild type.

Phenotypic effects of mutation are used differently by the geneticians. A base substitution which alters codon in mRNA resulting in different amino acid is referred to as missense mutation. A nonsense mutation changes a sense codon in to nonsense codon (one that terminates translation). The protein will become nonfunctional if the non-sense mutation occurs early in the mRNA sequence. A silent mutation alters a codon that still specifies the same aminoacid. This property of the codon is called redundancy of the genetic code. A neutral mutation is a missense mutation that alters the aminoacid sequence of the protein that does not change its function. Neutral mutations will occur when one aminoacid is replaced by another which is chemically similar or when the altered aminoacid has little effect on the structure of the protein. Induced mutations are produced by agents called mutagens. Mu-

tagens include chemical agents and radiation. Table describes some mutagens and their effects.

### Some Mutagens and their effects.

Mutagen	Effects
<b>Chemical agents</b> Base analogue Eg: caffeine, 5 – bromouracil	Substitutes “look – alike” molecules for the normal nitrogenous base during replication. Effect: point mutation
Alkylating agent Eg:nitrosoguanidine	Adds an alkyl group such as methyl group (-CH <sub>3</sub> ) to nitrogenous base, resulting in incorrect pairing. Effect: point mutation.
Deaminating agent Eg: nitrous acid, nitrates, nitrites	Removes an amino group (-NH <sub>2</sub> ) from a nitrogenous base Effect: point mutation.
Acridine derivative Eg: acridine dyes, quinacrine	Inserts into DNA ladder between backbones to form a new ring, distorting the helix. Effect: frame shift mutation.
<b>Radiation</b> Ultraviolet	Links adjacent pyrimidines to each other, as in thymine dimer formation, and there by impairs replication.
X – ray and gamma ray	Ionize and break molecules in cells to form free radicals, which inturn break DNA

### Isolation of Mutants:

Scientists have devised various methods for isolating bacterial mutants from a large population of the cells. The basic approach to mutant selection begins by exposure of large population of cells to a mutagen. After exposure the mutant is selected against the unmutated parent cells. When the mutagenic agent is used for mutant isolation, many cells acquire lethal mutations and die. However, a significant proportions of mutant and wild type (prototrophs) cells will survive.

Two sequential selection steps are used to isolate the mutants from the surviving population. Both the prototrophs and the mutants are grown on a given media containing penicillin. Penicillin sensitive prototrophs are killed by the penicillin. Nutritional mutants (Auxotrophic mutants) survive in this environment, because they cannot grow on minimal medium. This nutritional mutants are then isolated on a complete medium.

### Ames test

Many of the known mutagens are Carcinogens, i.e., they cause cancer in animals. The potential carcinogenicity of a mutagen can be tested on animals. These procedures are time consuming and expensive. Bruce Ames at the University of California has developed a faster and less expensive procedure for the preliminary screening of a potential carcinogen. This test is called as Ames test. The Ames test causes a back mutation in an auxotrophic strains of *Salmonella typhimurium*.

The Ames test is a screening test for the detection of carcinogenic compounds by testing the ability of chemical agents to induce bacterial mutations. All mutagenic agents are not carcinogenic; however, the correlation between carcinogenesis and mutagenicity is about 83%. The Ames test serves as a screening test to indicate whether a compound has carcinogenic potential or not. However, tests on animals are still required to prove carcinogenicity.

In conventional method, the material is injected into the animal and observed for the development of tumors. If tumor develops, it is presumed that the substance has carcinogenic potential. Eventhough, this method works well, it is time consuming.

The standard way to test a chemical for mutagenesis is by exposing the strains of auxotrophic bacteria to the chemical and measure the rate of back mutations. In Ames test a strain of *Salmonella typhimurium* strain TA 98, which is auxotrophic for histidine is exposed to a chemical agent. After chemical exposure and incubation on histidine deficient medium, the rate of reversion to prototrophy is determined by counting the number of colonies that are seen on the histidine-deficient medium.

### DNA repair

The integrity of the DNA is maintained even under constant pressure from radiation, chemical mutagens and spontaneously arising changes. The rate of mutation always remains low, because of the efficient DNA repair systems.

There are four general mechanisms of DNA repair.

1. Mismatch repair
2. Direct repair
3. Base Excision repair
4. Nucleotide Excision repair

### Mismatch repair

During replication process the incorrectly inserted nucleotides are recognized and removed. When the error is recognized, the mismatch repair enzymes cut out the distorted section of the newly synthesized DNA and fill the gap with new nucleotides by using the original DNA strand as a template.

### Direct repair

These mechanisms do not replace the altered nucleotides but instead, change them back into their original structure. The best characterized direct repair mechanism is photoreactivation of UV induced pyrimidine dimmers. *E.coli* and eukaryotic cells possess an enzyme called photolyase that uses energy captured from light to break the covalent bonds that link the pyrimidines in a dimer. This is also called light repair or photoreactivation.



## Base Excision repair

In this repair mechanism the modified bases are excised and the entire nucleotide is replaced. The removal of bases is catalysed by a set of enzymes called DNA glycosylases. They recognize and remove a specified type of modified base by cleaving the bond that links that base to the 1' – carbon atom of deoxyribose. For example, uracil glycosylase recognizes and removes uracil produced by the deamination of cytosine.

## Nucleotide – Excision repair

It is a complex process and removes bulky DNA lesions. A set of complex enzymes detect the distorted DNA and additional enzymes separate the two nucleotide strands at the damage region. The single strand binding proteins stabilize the separated strands. Then, the sugar – phosphate backbone of the damaged strand is cleaved on both sides of the damage. One cut is made five nucleotides upstream (on the 3' side) of the damage and the other cut is made eight nucleotides (in prokaryotes) or from 21 to 23 nucleotides (in eukaryotes) downstream (on the 5' side) of the damage. The damaged portion of the DNA is removed and the gap is filled in by DNA polymerase and sealed by DNA ligase

## Plasmids

In addition to having a chromosome, many bacteria possess plasmids. Plasmids are small, circular DNA molecules. Plasmids are extra chromosomal DNA molecules found in most bacterial species and in some eukaryotes. Plasmids depend on the metabolic functions of the host for their reproduction. Plasmids use most of the replication machinery of the host.

Some plasmids are present in many copies per cell, whereas some others are present in only one or two copies. Characteristically, plasmid can be eliminated from the host cells in a process known as curing. Some commonly used curing agents are acridine mutagens, UV, ionizing radiation, thymine starvation etc. Plasmids relatively have few genes, usually less than 30. Plasmids can be classified in terms of their mode of existence and spread.

Many types of plasmids are found in a variety of bacterial strains. *E. coli* strains contain three main types of plasmids, the F, R and Col plasmids. The presence of an F, R or Col plasmid in a cell indicates the following characteristics acquired by the cell.

F-Plasmid or sex plasmid has the ability to transfer chromosomal genes and to transfer F itself to a cell lacking the plasmid.

R plasmid or the drug resistance plasmid acquires resistance to one or more antibiotics and has the ability to transfer the resistance to the cells lacking R.

Col, or the Colicinogenic factor has the ability to synthesize colicin, a protein capable of killing closely related bacterial strains that lack the Col plasmids.

## Gene transfer

Genetic recombination refers to the exchange of genes between two DNA molecules to form new combinations of genes on a chromosome. Like mutation, genetic recombination contributes to a population genetic diversity, which is the source of variation in evolution.

Microorganisms carry out several types of recombinations. Before the 1920's bacteria were thought to reproduce only by binary fission and had no way of genetic transfer comparable to that of sexual reproduction in eukaryotes. Since then, three mechanisms of gene transfer in bacteria have been identified

1. Transformation
2. Transduction
3. Conjugation

### 1. Transformation

Bacterial transformation was discovered in 1928 by Frederick Griffith, an English physician. To understand the mechanism of transformation, the DNA was extracted from donor organisms by a biochemical process which yields hundreds of naked DNA fragments from the bacterial chromosome.

The extracted DNA when placed in a medium with organisms capable of incorporating it, was taken up by organisms to a maximum of about 10 fragments. Uptake of DNA occurs only at a certain stage in a cell's growth cycle. A protein, that is released at this stage called the competence factor facilitates the entry of DNA. Not all bacteria can become competent, and not all can be transformed. Once the DNA reaches the entry site, because of the action of endonuclease, the double stranded DNA is cut into 7000 – 10000 nucleotides and the two strands are separated. Inside the cell the donor single stranded DNA combines by base pairing with a portion of the recipient chromosome. In the recipient cell, the enzymes cut a portion of the recipient DNA and replace it with the donor DNA, which becomes a permanent part of the recipient chromosome.

#### **Significance of transformation:**

The extent to which transformation contributes to the genetic diversity of organisms in nature is not clear. However, in the laboratory transformation studies are carried out to study the effects of DNA that differs from the DNA that the organisms already possess. It is also used to study the location of genes on a chromosome and to insert DNA from one species to another, in order to produce recombinant DNA.

## **2. Transduction**

Transduction is a process in which DNA is carried by a bacteriophage (bacterial virus). The phenomenon of transduction was discovered by Joshua Lederberg and Norton Zinder in *Salmonella* in 1952.

There are two phage types. They are

1. Virulent phage
2. Temperate phage

The virulent phages destroy the host cell DNA and direct the synthesis of phage particles. Finally they cause lysis of the host cell and the process is called lytic cycle. Temperate phages can replicate themselves as part of the chromosome (called prophage) or produce new phage particles and lyse the host cell. Persistence of the phage in the cell without the destruction of the host cell is called lysogeny.

Transduction can be specialized or generalized. In specialized transduction, the phage is incorporated into the chromosome and may transfer only genes adjacent to the phage. In generalized transduction, the phage can transfer only DNA fragment attached to it.

#### **Significance of Transduction**

Transduction is significant because it transfers genetic material and shows a close evolutionary relationship between prophage and host cell DNA. Since it is persistent in a cell, suggests a mechanism for viral origins of cancer and also provides a possible mechanism for understanding linkage.

#### **Conjugation in Bacteria**

Another mechanism by which genetic material is transferred from one bacterium to another is known as conjugation. Conjugation was discovered by Joshua Lederberg and Edward L. Tatum in 1946 in *Escherichia coli*.

Conjugation is mediated by a circular piece of DNA, called Plasmid. Plasmids are the extrachromosomal DNA molecules. Conjugation process requires contact between living cells. The cell to cell contact for the conjugation to occur is established by the sex pili of the bacterium. One type of genetic donor is called  $F^+$  and the recipient cells are  $F^-$ .

$F^+$  cells contain plasmids called F factors. These F factors are transferred to the  $F^-$  cells during conjugation. When the plasmid becomes incorporated into the chromosome, the cell is called an Hfr (High frequency of recombination) cell. During conjugation, a Hfr cell can transfer chromosomal DNA to an  $F^-$  cell.

#### **Significance of conjugation**

The significance of conjugation is that it increases the genetic diversity. This may represent an evolutionary stage between asexual and sexual reproduction. It also provides a means for bacterial genome mapping.

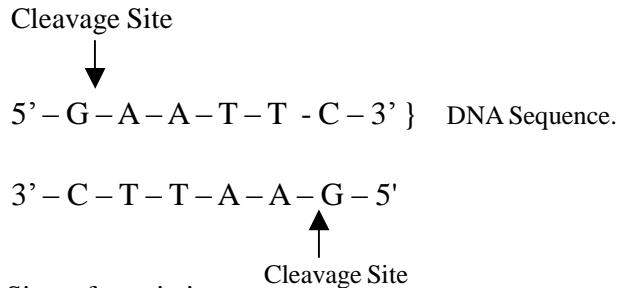
## Recombinant DNA methodology:

### Tools and Vectors

Genetic recombination of DNA occurs naturally in microbes as a process of gene transfer. From 1970 onwards scientists developed an artificial technique for making recombinant DNA. These techniques are called recombinant DNA technology. i.e., a process of forming a new combination of genes by artificial or natural means. For example, a gene from an animal can be inserted into the DNA of a bacterium, or a gene from a virus into a yeast. The recipient is then made to express the gene, which may code for a commercially useful product. The basic requirement for recombinant DNA technology is the availability of a DNA fragment.

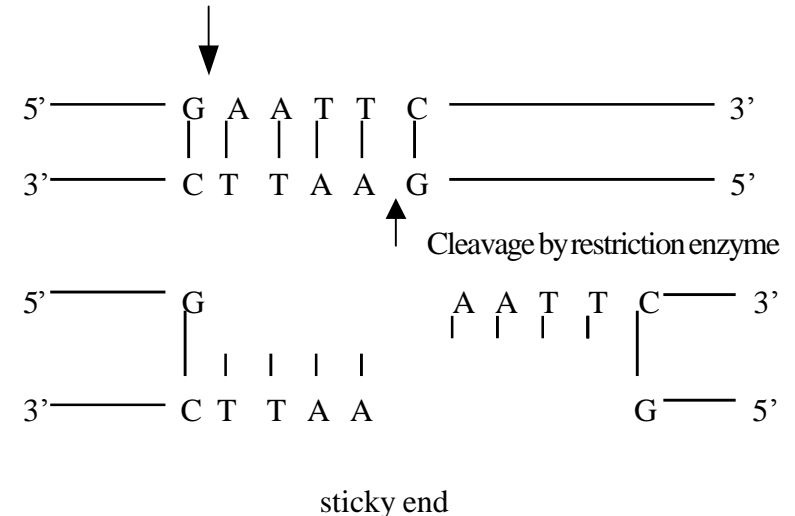
The DNA fragment can be generated by restriction enzymes. These are a special class of DNA cutting enzymes that exist in many bacteria. This was discovered in the late 1960s by Werner Arber and Hamilton Smith. These enzymes recognize and cut specific sequences of 4 to 6 base pairs long in double-stranded DNA.

The recognition sequences are always Palindromic sequences. i.e., reads the same on either direction of the DNA molecule. For example the restriction enzyme EcoRI isolated by Herbert Boyer in 1969 from *E.coli* cleaves the DNA between G and A in the base sequence GAATTC.



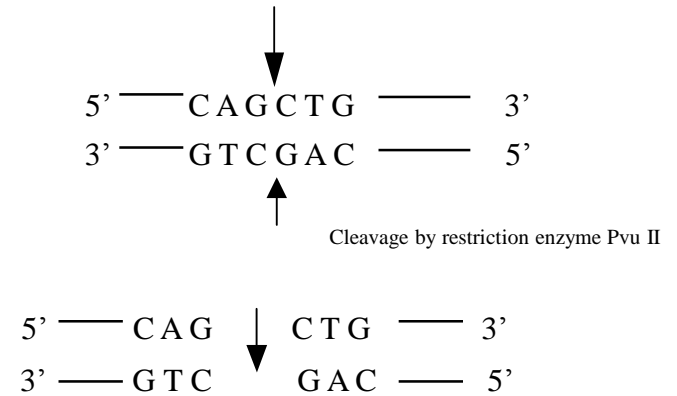
**Fig. 10-3** Cleavage Sites of restriction enzyme

When the two strands of DNA fragments separate, they form single-stranded complementary ends known as sticky ends or cohesive ends.



**Fig. 10-4** Mechanism of action of restriction enzyme

Not all restriction enzymes produce sticky ends. Some enzymes cut in the middle of its recognition site, producing blunt ended fragments.



**Fig. 10-5** Cleavage by restriction enzyme Pvu II

There are hundreds of restriction enzymes. A nomenclature for restriction enzymes was recommended by Smith and Nathans in 1973 and each enzyme is now represented by a three-letter code derived from the genus name of the bacteria from which the enzyme was isolated.

For Example

Hae – Enzyme isolated from *Haemophilus aegypticus*

Sma – Enzyme isolated from *Serratia marcescens*

Three kinds of restriction enzymes are currently known as Type I, Type II and Type III based on their property, action, and cleavage specificity on the DNA molecules.

The cohesive ends produced by the same restriction enzyme from different DNA strands will have complementary ends and will pair. When the cohesive ends have paired, the two DNA fragments can be joined together by the enzyme DNA ligase, which seals the nicks between the sugar-phosphate groups of the fragments.

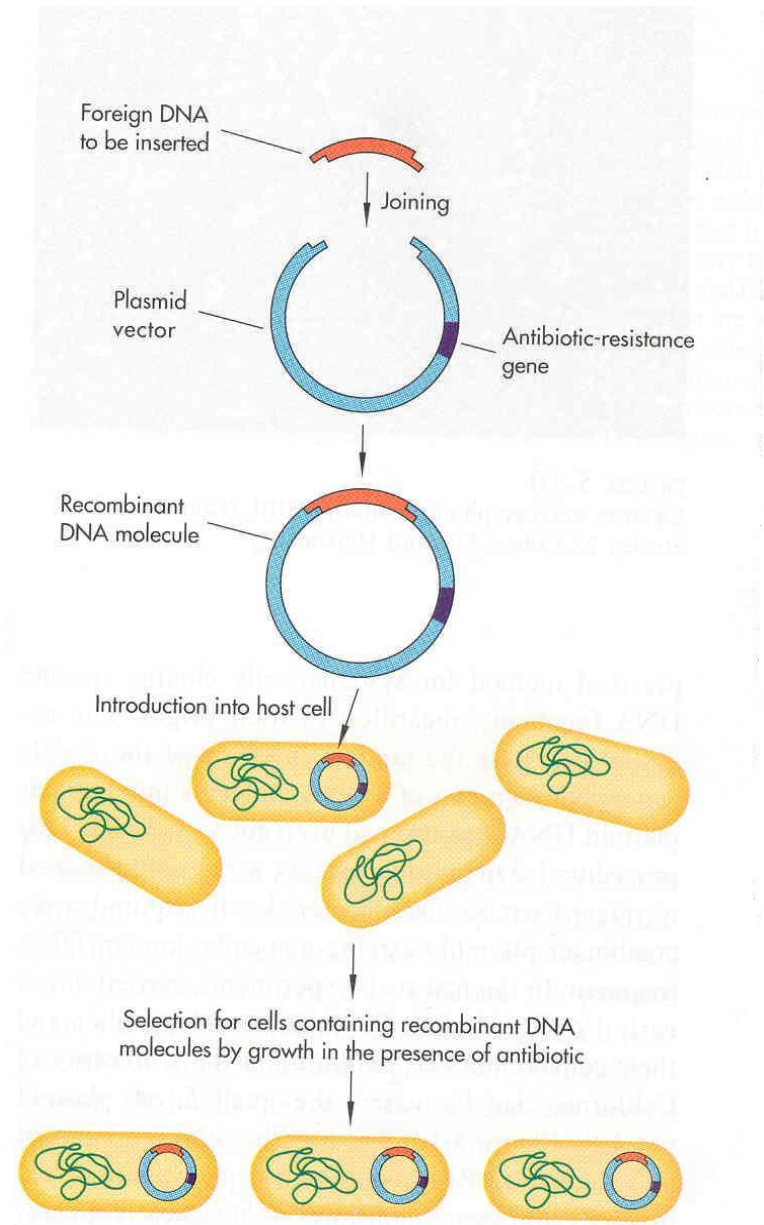
Fragments of DNA produced by restriction enzyme digestion cannot directly enter bacterial cells for cloning. It is joined to a vector. The vector can gain entry to a host cell, where it can be replicated or cloned into many copies. Vectors are the carrier of DNA molecules. To act as a vector, a DNA molecule must have the following properties.

1. Able to replicate independently.
2. Should contain a number of restriction enzyme cleavage sites.
3. Should carry a selectable marker (usually antibiotic resistant gene).
4. Should be easy to recover from the host cell.

There are number of vectors currently in use, which permit the cloning of DNA fragments over a wide size range, such as plasmid vectors, bacteriophage vectors, cosmid vectors, expression vectors, shuttle vectors, yeast artificial chromosomes etc.

The first recombinant plasmid capable of being replicated within a bacterial host was psc101 plasmid constructed by Stanley Cohen using transformation or phage injection. Each bacterial strain reproduces to yield a population containing a single type of recombinant molecule. The overall process is outlined in fig. 10-6.

The recombinant DNA opened up for the analysis of DNA from plants and animals. With the advent of new recombinant DNA procedures, now perfect methods of isolating desired DNA restriction fragments are available.



**Fig.10-6** Illustration of DNA fragment cloning in Plasmid

## Animal Biotechnology

### Cell Culture

Gene transfer techniques are used to produce transgenic animals. The potential prospects for animal biotechnology is the commercialization of cell and tissue based production of vaccines, monoclonal antibodies, pharmaceutical drugs, cancer research etc.

Animal cells can be cultured in artificial media in controlled conditions. However, the use of animal cells are restricted in terms of development potency. However, the use of animal cells are restricted in terms of development at an early developmental stage. Therefore, the only way to achieve germ line transformation in animals is to introduce DNA into totipotent cells prior to the developmental stage at which the germ line forms.

The first attempt to culture animal cells was started in 1907 by Ross Harrison. Thereafter the method was extended to culture mammalian cells *invitro*. There are many types of vertebrate cells which require support for growth in *invitro* conditions. These cells are called as anchorage-dependent cells. Plastic, glass or palladium is used as a substrate for such cells. The cell attachment to the substrate is increased by treatment with fibronectin or collagen. The chemical is drained, dried and the substrate is sterilized by UV light.

The medium for animal cell culture constitutes inorganic substances, provides the optimum growth factors. There are two types of media for animal cell culture.

1. Natural medium
2. Synthetic medium

The natural medium includes coagulants or plasma clots or biological fluids.

Synthetic media are of two types.

1. Serum – containing media
2. Serum – free media

The synthetic media are prepared by adding several organic and inorganic nutrients such as vitamins, salts, O<sub>2</sub>, CO<sub>2</sub> gas phases, serum proteins, carbohydrates, cofactors etc. Different types of synthetic media are used for different type of cells and tissues to be cultured. Prepared medium is sterilized by heat and steam or by filter sterilization.

### Isolation of animal tissue.

The animal materials are thoroughly washed with balanced salt solution and to avoid contamination with 70% ethanol and removed surgically under aseptic conditions. Some tissues consist of cells which are tightly aggregated. To get primary culture the tissue should be disaggregated by mechanical or enzymatic treatment. The dissociated cells are called as primary cells. The primary cells are seeded on culture medium in high density, and allowed to grow. The viable, primary cells adhere to the substrate. Such cells are called adherent cells and the culture is adherent culture.

The primary culture in the form of single cell suspension is sub-cultured by transferring into culture dishes and flasks containing special growth nutrients at optimal growth conditions. The unaltered form of cells grown for a limited number of generations is called cell line. The cell consists of similar or dissimilar lineages. A cell lineage with specific properties is called cell strain. The cell strain is cultured in large quantity in en masse in Bioreactors. The cultured cells are used for the production of human monoclonal antibodies and biochemicals.

Some important products produced from animal cell cultures are

1. Enzymes: Asperagenase, pepsin, Trypsin, rennin etc.,
2. Hormones: Leutinizing hormone. Follicle stimulating hormone etc.,
3. Vaccines: influenza vaccine, measles, mumps, rubella and rabies.
4. Monoclonal antibodies
5. Interferons.

### Transgenic animals

Transgenic animals are animals that carry foreign genes that have been artificially inserted into their genome. The foreign gene is constructed

using the recombinant DNA methodology. In addition to a structural gene, the foreign gene to be inserted also includes other sequences that enable it to be incorporated into the DNA of the host and to be correctly expressed by the cells of the host.

### Methods of producing transgenic animals:

The ability to introduce DNA into the germ line of mice is one of the greatest achievements of the twentieth century. There are two methods to produce transgenic mice.

1. Transforming embryonic stem cells (ES cells) growing in tissue culture with the desired DNA.
2. Injecting the desired gene into the pronucleus of a fertilized egg.

#### Method 1: Embryonic stem cell method:

The embryonic stem cells (ES cells) are harvested from the inner cell mass (ICM) of mouse blastocysts. They are grown in culture to retain their full potential to produce all the cells of the mature animal, including its gametes. Following the steps of recombinant DNA technology, DNA molecules containing the structural gene (for eg: insulin gene) and the vector sequences are made. Vector DNA helps to insert the insulin gene into the host DNA. It also carries the promoter and enhancer sequences to enable the gene to be expressed by the host.

The cultured cells are exposed to the recombinant DNA so that some will be incorporated into the ES cells. The successfully transformed cells will be selected and injected into the inner cell mass (ICM) of mouse blastocysts. A pseudopregnant mouse is developed by mating a female mouse with a vasectomized male. The stimulus of mating elicits the hormonal changes needed to make her uterus receptive. The embryos are transferred into her uterus. They will transplant and develop into healthy pups. To test the integration of the DNA, a small piece of tissue is removed from the tail and analysed for the desired gene. Not less than 10–20% will have the desired DNA and they will be heterozygous for the gene. Two heterozygous mice are mated and their offspring are screened for the 1 : 4 homozygous transgene.

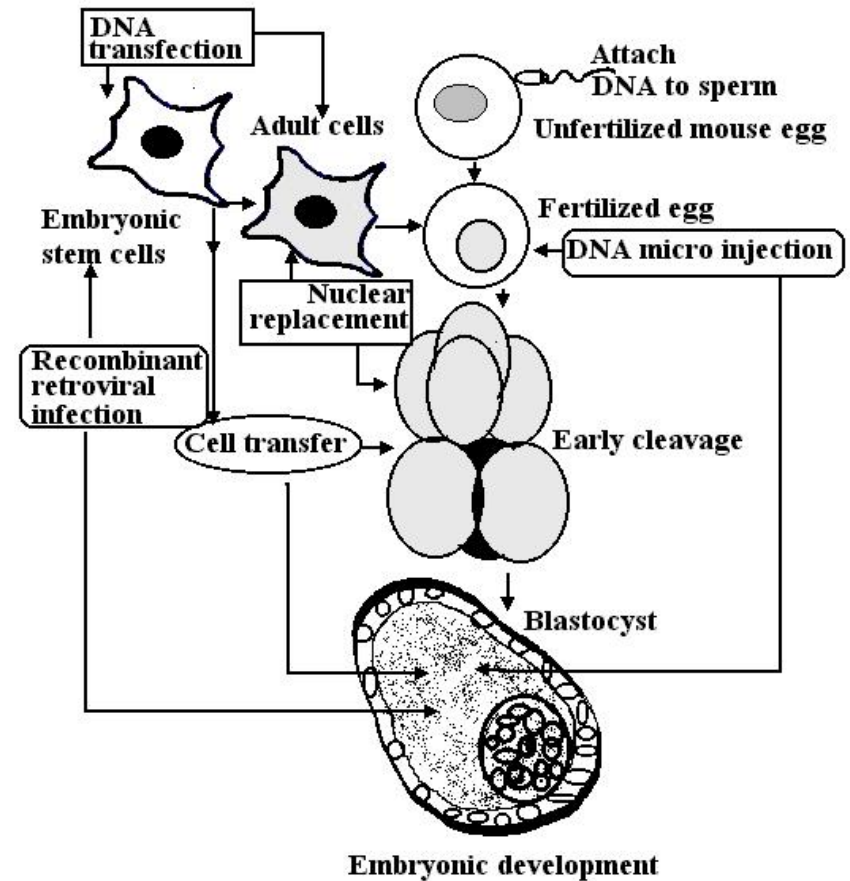


Fig. 10-7 Summary of the methods for producing Transgenic Animals

#### Method 2 Pronucleus method:

A freshly fertilized egg before the sperm head has become a pronucleus is harvested. The male pronucleus with the recombinant DNA is injected. The pronuclei are fused to form the diploid zygote nucleus and allowed to divide by mitosis to form a two cell embryo. The

embryos are implanted in a pseudopregnant foster mother. They implant successfully and develop into healthy pups. The procedure to establish transgenic animal is summarized in the fig.10-7.

Cloning or nuclear transfer, is the first stage in producing animal 'drug factories'. It allows transgenic animals to produce therapeutic chemicals for the treatment of cancer and other inflammation.

### **Examples of Transgenic animals:**

1. In February 1997, Dolly the sheep was born at the Roslin Institute in Edinburgh, the first clone of an adult mammal.
2. In January 1998, the two identical calves Molly and Polly (George and Charlie) with genetically engineered DNA having human gene expected to make them produce a protein helpful in blood clotting were created.

Following this US researchers have made the first modified monkey. The Rhesus monkey named ANDi ("inserted DNA") backwards received extra DNA while still an unfertilized egg. But, as with similar techniques, such as cloning, the method is far from perfect.

## **PLANT BIOTECHNOLOGY**

Conventional plant breeding requires a long time, and on an average, twelve generations of back crossing is required for a successful hybridization of two varieties. The new variety when entered into the field may have an effective lifetime of less than five years, because it becomes less competitive than higher yielding or more resistant varieties.

The modern high yielding varieties to have full potential yield require careful planning and application of fertilizers, plant growth regulators, herbicides and pesticides. All these methodologies are costly to agriculturists and it is a drain on energy resources. It is also a potential source for pollution.

New methods of crop development have given considerable promise for the future to indicate a change in crop protection. Gene cloning provides a new dimension to crop breeding to have direct changes on genotype of a plant. Two strategies are followed for plant biotechnology.

1. Gene addition – that is cloning is used to alter the characteristics of the plant by providing one or more new genes.
2. Gene substitution – in which genetic engineering techniques were used to inactivate one or more of the plant's existing genes.

The expression of foreign genes introduced into the plants was first demonstrated in early 1980's. At present we have more than 100 different plant species with genetic engineering methodology. The research on plant biotechnology is used to create plants with useful, genetically engineered characteristics such as insect resistance, herbicide tolerance, improved nutritional value etc. For gene transfer system, it is essential to have some of Tissue culture steps, which are a prequest for the successful production of transgenic plants.

### **Plant cell culture and protoplast:**

Tissue culture is a process, where a small piece of living tissue (explant) is isolated from a plant and grown aseptically for an indefinite period of time on a nutrient medium under environment controlled condition. The explant commonly selected are from cortex or meristematic tissues, such as buds, root tips, nodal segments or germinating seeds. For plant cells which develop into a callus, it is essential that a nutrient medium should be provided. Most media for a plant tissue culture contain inorganic salts, trace metals, vitamins organic nitrogen sources, inositol, sucrose and growth regulators. Before inoculating on to the nutrient medium, the explant has to be surface sterilized with sodium hypochlorite, hydrogen peroxide and mercuric chloride. The basic procedure for establishing and maintaining plant tissue culture is described in fig. 10-8.

On this medium the explant develops in to an undifferentiated mass of cells called callus. Once established, the callus can be propagated indefinitely by subdivision.

### Protoplast:

The callus when transferred into a liquid medium and agitated, will break to give suspension of isolated cells. Plant cells without cell walls are called protoplast. Protoplast can be produced from suspension cultures, callus tissue or intact tissue by treating them with cellulolytic and pectinolytic enzymes. Protoplasts are useful for plant cell manipulation. Protoplasts of similar or contrasting cell types can be fused to form hybrids. This process is known as protoplasmic fusion. When the protoplasts are placed on a nutrient medium they synthesize new cell walls within 5 to 10 days. These cells show a high degree of homogeneity and can yield a callus genetic stability.

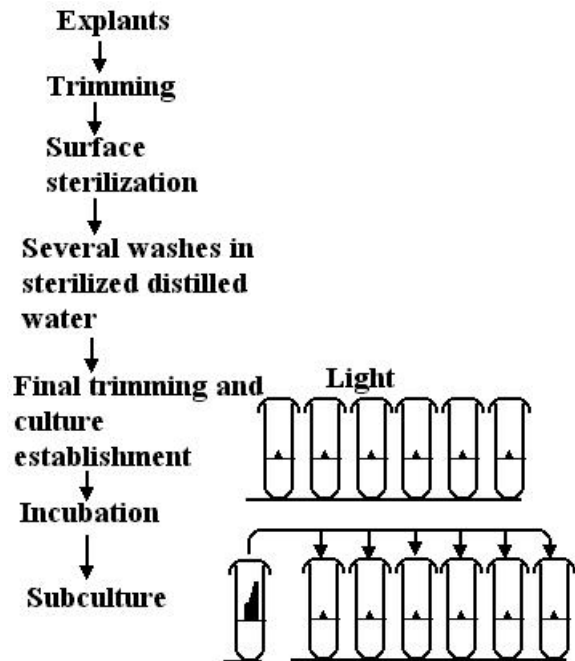


Fig.10-8: Basic procedure for Tissue culture and Subculture maintenance.

### Gene transfer:

Gene transfer to plants can be achieved by a bacterium called *Agrobacterium tumefaciens*. It is a gram negative, soil bacterium and a phytopathogen. During its normal part of the life cycle, the bacteria

can genetically transform plant cells. The genetic transformation leads to the formation of crown gall tumors. This crown gall disease is one of the agronomically important diseases and affects only the dicotyledonous plants. Crown gall formation is due to the transfer, integration, and expression of specific segments of bacterial plasmid DNA. Since this plasmid DNA induces a tumor like disease, is called as Ti plasmid (tumor induced). *Agrobacterium tumefaciens* harbours large plasmids (140 – 235 kilobase). The *Agrobacterium tumefaciens* has the capacity for unlimited growth as a callus in tissue culture, in media without hormones it also induces the synthesis of opines, the unusual amino acid derivatives not found in normal plants.

Based on the opine synthesis two type of plasmids are grouped. 1. Octopine Ti plasmid and 2. Nopaline Ti – plasmid (fig.10-9).

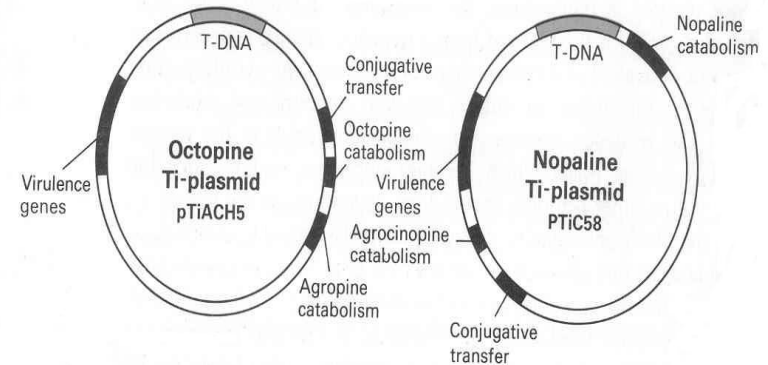


Fig. 10-9 Structure of Ti plasmid

The DNA that gets integrated in to the plant genome is called T DNA. The T-DNA region can vary from approximately 12 to 24 kilobase. There is a sequence of steps in the process of infection. The soil bacterium responds to certain plant phenolic compounds such as acetosyringone and hydroxy acetosyringone which are excreted by susceptible wounded plant. These molecules induce the virulence genes on the Ti plasmid. The products for the *vir* genes are essential for the



transfer and integration of T DNA region. The T DNA is transferred by a process which is similar to plasmid transfer from donor to recipient cell during conjugation. Once the T-DNA enters the plant it causes a crown gall disease.

### Ti plasmid derived vector system:

The simplest way to exploit the ability of Ti plasmid to genetically transform plants is to insert a desired DNA sequence in to the TDNA region. Then the Ti plasmid and the *A.tumefaciens* are used to deliver and insert the genes in to the genome of susceptible plant cell.

A simple procedure has been developed by Horsch and his group in 1985, which has been widely used in genetic engineering of plants (*Agrobacterium* mediated gene transfer).

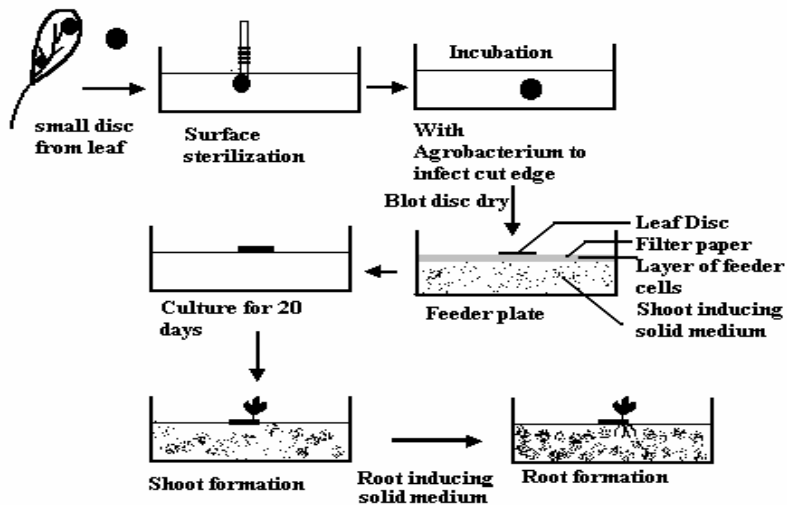


Fig.10-10 Leaf disc transformation by Ti – plasmid vectors

Small discs were punched off from leaves. The discs were surface sterilized and inoculated on to a culture medium containing *A.tumefaciens* transformed with recombinant genes. The discs were cultured for two days and transferred to a medium containing kanamycin and carbanicillin. Carbanicillin is used to kill the *Agrobacterium*. Following two to three weeks of incubation developed shoots were excised from the callus and transplanted to root induction medium. Plantlets that develop roots were subsequently transplanted to soil at about four to seven weeks after the inoculation step.

### Practicals

1. Gram's staining
2. Acid fast staining
3. Demonstration of rhizobium from root nodules
4. Kirby - Bauer technique of antibiotic sensitivity testing
5. Evaluation of disinfectants
6. Fermentation reaction\_gas production - Durham's tube technique
7. Biogas production
8. Mushroom cultivation - observation
9. Composting : Demonstration of microbial diversity
10. MPN test
11. Growth curve - turbidity method
12. Examination of yeast budding
13. Microscopic observation of curd
14. Observation of microbes from idly batter
15. Widal test
16. Blood grouping
17. Observation of heterocyst
18. Examination of fungal asexual spores
19. Gel diffusion technique
20. Examination of Tikka leaf spot/citrus canker