

# PHYSICS

## HIGHER SECONDARY SECOND YEAR

### VOLUME - II

Revised based on the recommendation of the  
Textbook Development Committee

Untouchability is a sin

Untouchability is a crime

Untouchability is inhuman

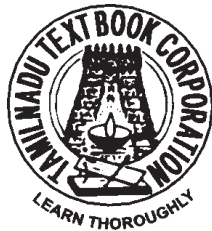

TAMILNADU TEXTBOOK  
CORPORATION

COLLEGE ROAD, CHENNAI - 600 006

© Government of Tamilnadu  
First edition - 2005  
Revised edition - 2007

CHAIRPERSON  
**Dr. S. GUNASEKARAN**

Reader  
Post Graduate and Research Department of Physics  
Pachaiyappa's College, Chennai - 600 030

#### REVIEWERS

##### **P. SARVAJANA RAJAN**

Selection Grade Lecturer in Physics  
Govt.Arts College  
Nandanam, Chennai - 600 035

##### **S. KEMASARI**

Selection Grade Lecturer in Physics  
Queen Mary's College (Autonomous)  
Chennai - 600 004

##### **Dr. K. MANIMEGALAI**

Reader in Physics  
The Ethiraj College for Women  
Chennai - 600 008

##### **G. SANKARI**

Selection Grade Lecturer in Physics  
Meenakshi College for Women  
Kodambakkam, Chennai - 600 024

##### **G. ANBALAGAN**

Lecturer in Physics  
Aringnar Anna Govt. Arts College  
Villupuram.

#### AUTHORS

##### **S. PONNUSAMY**

Asst. Professor of Physics  
S.R.M. Engineering College  
S.R.M. Institute of Science and Technology  
(Deemed University)  
Kattankulathur - 603 203

##### **S. RASARASAN**

P.G. Assistant in Physics  
Govt. Hr. Sec. School  
Kodambakkam, Chennai - 600 024

##### **GIRIJA RAMANUJAM**

P.G. Assistant in Physics  
Govt. Girls' Hr. Sec. School  
Ashok Nagar, Chennai - 600 083

##### **P. LOGANATHAN**

P.G. Assistant in Physics  
Govt. Girls' Hr. Sec. School  
Tiruchengode - 637 211  
Namakkal District

##### **Dr. N. VIJAYAN**

Principal  
Zion Matric Hr. Sec. School  
Selaipur  
Chennai - 600 073

##### **Dr. HEMAMALINI RAJAGOPAL**

Senior Scale Lecturer in Physics  
Queen Mary's College (Autonomous)  
Chennai - 600 004

Price : Rs.

This book has been prepared by the Directorate of School Education on behalf of  
the Government of Tamilnadu

This book has been printed on 60 G.S.M paper

Printed by of ~~fst~~ at :

## Preface

The most important and crucial stage of school education is the higher secondary level. This is the transition level from a generalised curriculum to a discipline-based curriculum.

In order to pursue their career in basic sciences and professional courses, students take up Physics as one of the subjects. To provide them sufficient background to meet the challenges of academic and professional streams, the Physics textbook for Std. XII has been reformed, updated and designed to include basic information on all topics.

Each chapter starts with an introduction, followed by subject matter. All the topics are presented with clear and concise treatments. The chapters end with solved problems and self evaluation questions.

Understanding the concepts is more important than memorising. Hence it is intended to make the students understand the subject thoroughly so that they can put forth their ideas clearly. In order to make the learning of Physics more interesting, application of concepts in real life situations are presented in this book.

Due importance has been given to develop in the students, experimental and observation skills. Their learning experience would make them to appreciate the role of Physics towards the improvement of our society.

The following are the salient features of the text book.

- The data has been systematically updated.
- Figures are neatly presented.
- Self-evaluation questions (only samples) are included to sharpen the reasoning ability of the student.

***While preparing for the examination, students should not restrict themselves, only to the questions/problems given in the self evaluation. They must be prepared to answer the questions and problems from the text/syllabus.***

**- Dr. S. Gunasekaran**  
Chairperson

# CONTENTS

	<b>Page No.</b>
6. Atomic Physics	1
7. Dual Nature of Radiation and Matter and Relativity	56
8. Nuclear Physics	83
9. Semiconductor Devices and their Applications	131
10. Communication Systems	198
Appendix	238
Logarithmic and other tables	242

## 6. Atomic Physics

At atmospheric pressure, air and other gases are poor conductors of electricity. This is because, they do not have free charged particles. However, electric current may be passed through a gas if by some mechanism, charged particles are produced in the gas. This can be done in many ways, such as (i) by applying a large potential difference across a gas column at very low pressure and (ii) by allowing X-rays to pass through the gases.

The study of electric discharge through gases gives valuable information regarding the structure of atoms. This has led to the discovery of electrons by J. J. Thomson and later on, to the discovery of X-rays by Roentgen.

### 6.1 Discharge of electricity through gases at low pressure - Discovery of electrons

A discharge tube is an arrangement to study the conduction of electricity through gases. It is a closed, strong glass tube of length 50 cm and diameter 4 cm, filled with a gas. Two metal electrodes C and A are fitted inside

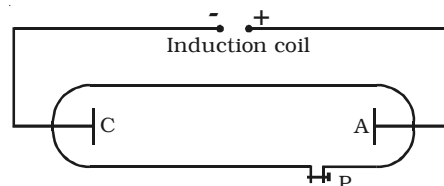

Fig 6.1 Discharge tube

the tube at the ends as shown in Fig 6.1. The side tube P is connected to a high vacuum pump and a low pressure gauge. The electrodes C and A are connected to the secondary of a powerful induction coil, which maintains a potential difference of 50,000 V. The electrode C connected to the negative terminal of the induction coil is called the cathode and the electrode A connected to the positive terminal is called the anode.

When the pressure of the gas inside the discharge tube is reduced by working the vacuum pump, to about 110 mm of Hg, no discharge occurs through the tube. At a pressure of about 100 mm of Hg, the discharge of electricity through the gas begins and irregular streaks of

light appear, accompanied by a crackling sound. As the pressure is reduced to the order of 10 mm of Hg, the irregular streaks broaden out into a luminous column extending from the anode, almost upto the cathode. This column is known as the positive column. With further reduction in pressure to around 0.01 mm of Hg, the positive column disappears and Crooke's dark space fills the whole tube. At this stage, the walls of the glass tube fluoresce with green colour. This greenish glow in the final stage of the gaseous discharge is found to be a fluorescence of the glass produced by some invisible rays emanating from the cathode (shown in the wrapper). These rays are called cathode rays and are found to be electrons.

### **6.1.1 Properties of Cathode rays**

Cathode rays have the following properties:

- (i) They travel in straight lines.
- (ii) Cathode rays possess momentum and kinetic energy.
- (iii) Cathode rays produce heat, when allowed to fall on matter.
- (iv) Cathode rays produce fluorescence when they strike a number of crystals, minerals and salts.
- (v) When cathode rays strike a solid substance of large atomic weight, X-rays are produced.
- (vi) Cathode rays ionize the gas through which they pass.
- (vii) Cathode rays affect the photographic plates.
- (viii) The cathode rays are deflected from their straight line path by both electric and magnetic fields. The direction of deflection shows that they are negatively charged particles.
- (ix) Cathode rays travel with a velocity upto  $(1/10)^{\text{th}}$  of the velocity of light.
- (x) Cathode rays comprises of electrons which are fundamental constituents of all atoms.

### 6.1.2 Positive rays (or) Canal rays

While conducting experiments on the gas discharge, in 1886, German Physicist, E. Goldstein, discovered that if the cathode used is perforated,

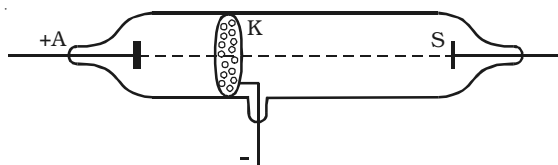

Fig 6.2 Production of canal rays.

luminous streams appeared in the tube behind the cathode. These streams were called as canal rays. The discharge tube designed by Goldstein is shown in Fig 6.2. The tube contains an anode (A), a perforated cathode (K) and a fluorescent screen (S). At a pressure of about 1mm of mercury, a luminous stream of particles were observed behind the cathode proceeding in a direction opposite to that of the cathode rays. Goldstein, called them as canal rays, since they pass through and emerge from the holes, in the cathode in straight lines, opposite to the direction of the cathode rays. From the nature of the deflection produced, by a magnetic field or electric field, these rays were found to be positively charged particles. Hence, canal rays are most commonly known as positive rays.

#### Properties of Canal rays

- (i) They are the streams of positive ions of the gas enclosed in the discharge tube. The mass of each ion is nearly equal to the mass of the atom.
- (ii) They are deflected by electric and magnetic fields. Their deflection is opposite to that of cathode rays.
- (iii) They travel in straight lines.
- (iv) The velocity of canal rays is much smaller than the velocity of cathode rays.
- (v) They affect photographic plates.
- (vi) These rays can produce fluorescence.
- (vii) They ionize the gas through which they pass.

### 6.1.3 Determination of specific charge ( $e/m$ ) of an electron – Thomson's method.

In 1887, J.J. Thomson, measured the specific charge ( $e/m$ ) of the cathode ray particles. The specific charge is defined as the charge per unit mass of the particle. Thomson discovered that the value of ( $e/m$ ) was independent of the gas used and also independent of the nature of the electrodes.

#### Principle

The fact that the cathode rays (electrons) are deflected by electric and magnetic fields is made use of in this method.

#### Experimental arrangement

A highly evacuated discharge tube used in this experiment is as shown in Fig. 6.3. Cathode rays are produced by the discharge between

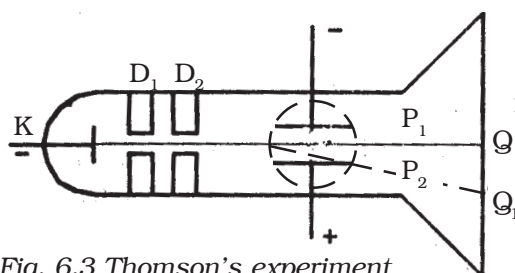

Fig. 6.3 Thomson's experiment

the cathode and the anodes  $D_1$  and  $D_2$ . A thin pencil of cathode ray comes out through fine pin holes in the anode discs. The cathode rays then pass between two parallel metal plates  $P_1$  and  $P_2$  and strike the flat face of the tube. This face is coated with suitable fluorescent material. A spot of

light is produced at  $Q$ . But when a potential difference  $V$  is applied between  $P_1$  and  $P_2$ , the beam is deflected to point  $Q_1$ . By the use of a pair of coils, uniform magnetic field is produced perpendicular to the plane of the paper and outwards through out the region between  $P_1$   $P_2$ .

#### Theory

##### 1. Determination of $V$

With a given electric intensity between the plates  $P_1$  and  $P_2$  the magnetic induction  $B$  is adjusted until the beam strikes the screen at the original position  $Q$ . Then the downward force  $Ee$  due to the electric field is balanced by the force  $Bev$  due to magnetic induction where  $e$  is the charge of the cathode ray particle and  $v$  is the velocity of the cathode rays.



$$Ee = Bev$$

$$v = \frac{E}{B} \quad \dots(1)$$

## 2. Determination of $e/m$

Now the magnetic induction is switched off. The deflection  $Q Q_1 = y$  caused by the electric field alone is measured. At the instant when the cathode rays enter the region between the plates  $P_1$  and  $P_2$ , initial velocity in the downward direction  $u = 0$

Acceleration along the downward direction  $a = \frac{Ee}{m}$ , where  $m$  is the mass of each cathode ray particle.

Time for which the electron moves in the electric field  $t = \frac{l}{v}$  where  $l$  is the length of either of the plates and  $v$  is the velocity of the electron.

The deflection produced on the cathode rays along the downward direction in the electric field is given by

$$y_1 = \frac{1}{2} \left( \frac{Ee}{m} \right) \left( \frac{l}{v} \right)^2 \quad \dots (2)$$

Substituting for  $v$  from equation (1) in equation (2) we get

$$y_1 = \frac{1}{2} \left( \frac{Ee}{m} \right) \left( \frac{l^2}{E^2} \right) B^2 = \frac{1}{2} \frac{e}{m} \frac{l^2 B^2}{E}$$

The displacement of the spot of light on the screen is given by (Fig 6.4)

$y = K y_1$ , where  $K$  is a constant determined by the geometry of the discharge tube. Substituting for  $y_1$  we get,

$$y = K \frac{1}{2} \frac{e}{m} \frac{l^2 B^2}{E} \quad \dots(3)$$

$$\frac{e}{m} = \frac{2yE}{Kl^2 B^2} \quad \dots(4)$$

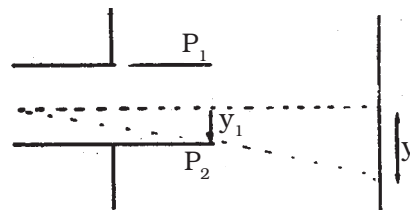

Fig. 6.4 Path of an electron in the electric field

By substituting the known values in the above relation  $e/m$  of an electron can be calculated. The value of  $e/m$  calculated using this experiment was found to be  $1.7592 \times 10^{11} \text{ C kg}^{-1}$

Note: The value of  $e/m$  of an electron can also be calculated, by applying uniform magnetic field perpendicular to the path of the electron.

#### **6.1.4 Determination of charge of an electron – Millikan's oil drop experiment**

Millikan's experiment is used for the measurement of charge of an electron.

##### **Principle**

This method is based on the study of the motion of uncharged oil drop under free fall due to gravity and charged oil drop in a uniform electric field. By adjusting uniform electric field suitably, a charged oil drop can be made to move up or down or even kept balanced in the field of view for sufficiently long time and a series of observations can be made.

##### **Experimental arrangement**

The apparatus consists of two horizontal circular metal plates A and B, about 22 cm in diameter and separated by a distance of about 16 mm as shown in Fig 6.5. The upper plate has a hole (H) in the middle. These plates are held together by insulating rods of glass or ebonite, so that they are perfectly parallel to each other.

The plates are surrounded by a constant temperature bath D and the chamber C containing dry air. The plates are connected to a battery which can provide a potential difference of the order of 10000 V.

##### **Theory**

A spray of fine droplets of a highly viscous liquid (such as glycerine) is produced by means of an atomiser (AT) near the hole H and enter the space between A and B. The droplets are illuminated by an arc lamp L and are seen through a microscope whose eyepiece is provided with a micrometer scale. One such droplet is viewed through the microscope as it descends under gravity. The viscous force due to air increases and soon it attains a constant terminal velocity and let it be  $v$ . The terminal velocity  $v$  of the droplet is measured using the microscope.

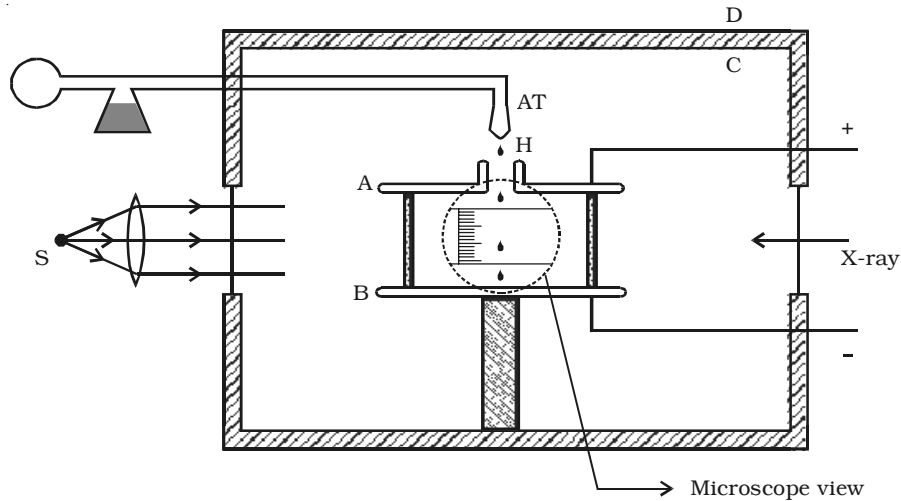

Fig 6.5 Millikan's oil drop experiment

**(i) Motion under gravity**

The gravitational force acting on the oil drop downwards is equal to  $mg = \frac{4}{3} \pi a^3 \rho g$ , where  $a$  is the radius of the oil drop,  $\rho$  is the density of the oil and  $g$ , the acceleration due to gravity.

The upthrust experienced by the oil drop due to the displaced air is  $\frac{4}{3} \pi a^3 \sigma g$ , where  $\sigma$  is the density of air.

$\therefore$  The net downward force acting on the oil drop = weight of the oil drop – upthrust experienced by the oil drop.

$$\begin{aligned}
 &= \frac{4}{3} \pi a^3 \rho g - \frac{4}{3} \pi a^3 \sigma g \\
 &= \frac{4}{3} \pi a^3 (\rho - \sigma) g \quad \dots(1)
 \end{aligned}$$

Since the oil drop attains a terminal velocity  $v$ , the net downward force acting on the oil drop is equal to the viscous force acting opposite to the direction of motion of the oil drop.

By Stoke's law, the viscous force on the oil drop is  $6\pi a\eta v$ , where  $\eta$  is the co-efficient of viscosity of air.

$$\frac{4}{3}\pi a^3(\rho - \sigma)g = 6\pi a\eta v \quad \dots(2)$$

The radius of the oil drop is,

$$a = \left[ \frac{9\eta v}{2(\rho - \sigma)g} \right]^{\frac{1}{2}} \quad \dots(3)$$

### **(ii) Motion under electric field**

The air inside the parallel plates is ionized by sending a beam of X-rays. The droplets pickup one or more electrons from the ionized air.

Let  $q$  be the charge carried by the droplet under observation. Let  $E$  be the electric field applied between the plates A and B, so that the drop moves upwards with a terminal velocity  $v_1$ , which can be determined using the microscope.

The force on the droplet due to electric field is  $Eq$ . Since the velocity of the droplet is uniform, we have

$$Eq = \frac{4}{3}\pi a^3(\rho - \sigma)g + 6\pi a\eta v_1$$

$$\therefore Eq - \frac{4}{3}\pi a^3(\rho - \sigma)g = 6\pi a\eta v_1 \quad \dots(4)$$

Adding equations (2) and (4),

$$Eq = 6\pi a\eta(v + v_1) \quad \dots(5)$$

Substituting the value of  $a$  in equation (5) from equation (3),

$$Eq = 6\pi\eta^{3/2}(v + v_1) \left[ \frac{9v}{2(\rho - \sigma)g} \right]^{\frac{1}{2}} \quad \dots(6)$$

If  $V$  is the potential difference between A and B,  $d$  is the distance between them, then  $E = \frac{V}{d}$

Millikan determined the value  $q$  for a large number of oil drops using equation (6) and found that they are an integral multiple of a

least value. The greatest common factor gives the charge  $e$  of the electron.

The charge of an electron was found to be  $1.602 \times 10^{-19}$  coulomb.

## 6.2 Atom models

As far back as 1803, Dalton, an English teacher, showed that the matter is made up of extremely small particles called atoms. Prout (1815), suggested that all elements are made up of atoms of hydrogen. Since many of the elements were found to have atomic weights that were not exact multiples of that of hydrogen, the suggestion was not accepted. After the discovery of radioactivity and electron, interest in the study of atomic structure increased and many models of atom were suggested at different times.

### 6.2.1 Thomson atom model

From the study of discharge of electricity through gases, it became clear that an atom consists of positive and negative charges. J.J. Thomson tried to explain the arrangement of positive charge and the electrons inside the atom. According to him, an atom is a sphere of positive charge having a radius of the order of  $10^{-10}$ m. The positive charge is uniformly distributed over the entire sphere and the electrons are embedded in the sphere of positive charge as shown in Fig 6.6. The total positive charge inside the atom is equal to the total negative charge carried by the electrons, so that every atom is electrically neutral.

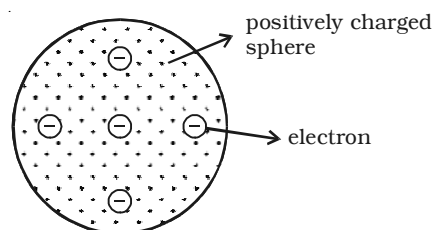

Fig 6.6 Thomson atom model

According to Thomson, if there is a single electron in the atom (like a hydrogen atom), the electron must be situated at the centre of the positive sphere. For an atom with two electrons (helium atom), the electrons should be situated symmetrically with respect to the centre of

the sphere i.e., opposite sides of the centre at a distance of  $\frac{r}{2}$ , where  $r$  is the radius of the positive sphere. In a three electron system of the atom, the electrons should be at the corners of a symmetrically placed equilateral triangle, the side of which was equal to the radius of the

sphere. In general, the electrons of an atom are located in a symmetrical pattern with respect to the centre of the sphere.

It was suggested that spectral radiations are due to the simple harmonic motion of these electrons on both sides of their mean positions. Moreover, the stability of the atom was very well explained on the basis of this model.

### **Drawbacks**

(i) According to electromagnetic theory, the vibrating electron should radiate energy and the frequency of the emitted spectral line should be the same as the electron. In the case of hydrogen atom, Thomson's model gives only one spectral line of about  $1300 \text{ \AA}$ . But the experimental observations reveal that hydrogen spectrum consists of five different series with several lines in each series.

(ii) It could not account for the scattering of  $\alpha$ -particles through large angles.

### **6.2.2 Rutherford's $\alpha$ - particle scattering experiment**

Rutherford and his associates studied the scattering of the  $\alpha$  - particles by a thin gold foil in order to investigate the structure of the atom. An  $\alpha$ -particle is a positively charged particle having a mass equal to that of helium atom and positive charge in magnitude equal to twice the charge of an electron. They are emitted by many radioactive elements. The scattering of  $\alpha$ -particles provide useful information about the structure of the atom.

#### **Experimental arrangement**

A fine pencil of  $\alpha$ -particles was obtained from a radioactive material like radium or radon by placing it in a lead box with narrow opening as shown in Fig 6.7.

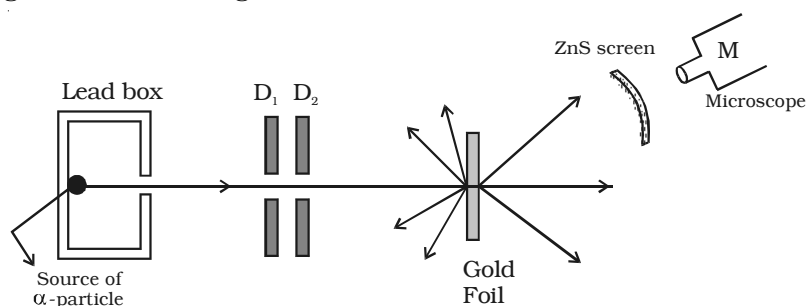

*Fig 6.7 Rutherford's  $\alpha$  - particle scattering experiment*

The  $\alpha$ -particles are emitted from the source in all possible directions, but only a narrow beam emerges from the lead box. The remaining  $\alpha$ -particles are absorbed in the lead box itself. After passing through the diaphragms  $D_1$  and  $D_2$ , a narrow beam of  $\alpha$ -particles incident on a thin gold foil, are scattered through different angles. The scattered  $\alpha$ -particles strike a fluorescent screen coated with zinc sulphide. When the  $\alpha$ -particles strike the screen, tiny flashes of light are produced. The observations can be made with the help of a low power microscope.

### **Observations and conclusions**

(i) Most of the  $\alpha$  particles either passed straight through the gold foil or were scattered by only small angles of the order of a few degrees. This observation led to the conclusion that an atom has a lot of empty space as shown in Fig 6.8.

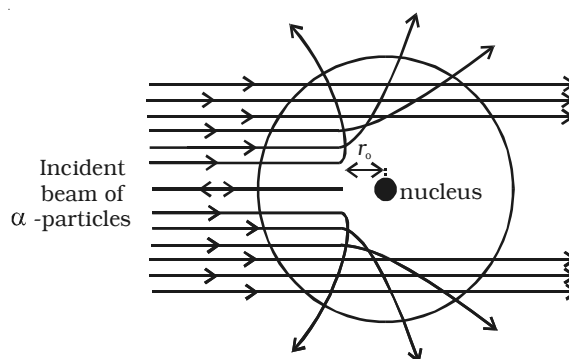

Fig 6.8 Scattering of  $\alpha$  - rays

(ii) A few  $\alpha$  particles were scattered in the backward direction, which led Rutherford to conclude that the whole of the positive charge was concentrated in a tiny space of about  $10^{-14}\text{m}$ . This region of the atom was named as nucleus. Only a small number of particles approaches the nucleus of the atom and they were deflected at large angles.

### **Distance of closest approach**

An  $\alpha$  particle directed towards the centre of the nucleus will move close upto a distance  $r_0$  as shown in Fig 6.8, where its kinetic energy will appear as electrostatic potential energy. After this, the  $\alpha$  particle begins to retrace its path. This distance  $r_0$  is known as the distance of the closest approach.

Let  $m$  and  $v$  be the mass and velocity of the  $\alpha$  particle directed towards the centre of the nucleus. Then, the kinetic energy of the particle,

$$E_k = \frac{1}{2}mv^2 \quad \dots(1)$$

Since, charge of an  $\alpha$ -particle is  $2e$  and that of the nucleus of the atom is  $Ze$ , the electrostatic potential energy of the  $\alpha$  particle, when at a distance  $r_o$  from the centre of the nucleus is given by,

$$E_p = \frac{1}{4\pi\epsilon_o} \cdot \frac{(2e)(Ze)}{r_o} \quad \dots(2)$$

where  $Z$  is the atomic number of the atom and  $\epsilon_o$ , the permittivity of free space.

On reaching the distance of the closest approach  $r_o$ , the kinetic energy of the  $\alpha$  particle appears as its potential energy.

$$\therefore E_p = E_k$$

$$\frac{1}{4\pi\epsilon_o} \cdot \frac{(2e)(Ze)}{r_o} = \frac{1}{2}mv^2$$

$$(or) \quad r_o = \frac{1}{4\pi\epsilon_o} \cdot \frac{4Ze^2}{mv^2} \quad \dots(3)$$

### 6.2.3 Rutherford atom model

Based on the results of  $\alpha$ -particle scattering experiment, Rutherford suggested the following picture of the atom.

(i) Atom may be regarded as a sphere of diameter  $10^{-10}m$ , but whole of the positive charge and almost the entire mass of the atom is concentrated in a small central core called nucleus having diameter of about  $10^{-14}m$  as shown in Fig 6.9a.

(ii) The electrons in the atom were considered to be distributed around the nucleus in the empty space of the atom. If the electrons were at rest, they would be attracted and neutralized by the nucleus. To overcome this, Rutherford suggested that the electrons are revolving around the nucleus in circular orbits, so that the centripetal force is provided by the electrostatic force of attraction between the electron and the nucleus.



(iii) As the atom is electrically neutral, the total positive charge of the nucleus is equal to the total negative charge of the electrons in it.

### **Drawbacks**

Rutherford atom model offered serious difficulties as regards the stability of the atom. Following are the two drawbacks of Rutherford's model: (i) The electron in the circular orbit experiences a centripetal acceleration. According to electromagnetic theory, an accelerated

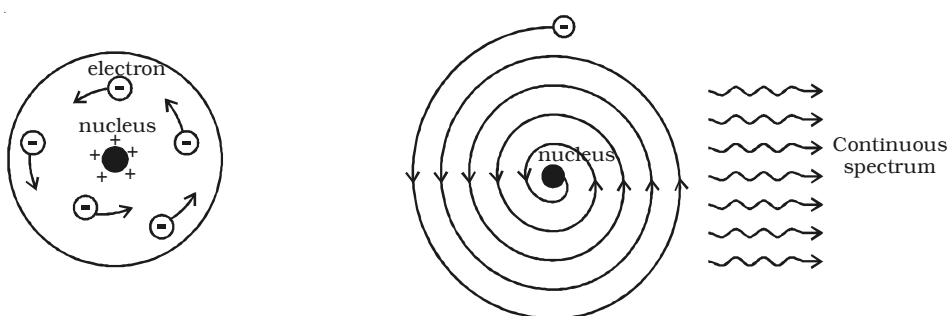

*Fig 6.9a Rutherford atom model      Fig 6.9b Motion of electrons in spiral path into the nucleus.*

electric charge must radiate energy in the form of electromagnetic waves. Therefore, if the accelerated electron lose energy by radiation, the energy of the electron continuously decreases and it must spiral down into the nucleus, as shown in Fig 6.9b. Thus, the atom cannot be stable. But, it is well known that most of the atoms are stable. (ii) According to classical electromagnetic theory, the accelerating electron must radiate energy at a frequency proportional to the angular velocity of the electron. Therefore, as the electron spiral towards the nucleus, the angular velocity tends to become infinity and hence the frequency of the emitted energy will tend to infinity. This will result in a continuous spectrum with all possible wavelengths. But experiments reveal only line spectra of fixed wavelength from atoms.

### **6.2.4 Bohr atom model**

Neils Bohr in 1913, modified Rutherford's atom model in order to explain the stability of the atom and the emission of sharp spectral lines. He proposed the following postulates :

(i) An electron cannot revolve round the nucleus in all possible orbits. The electrons can revolve round the nucleus only in those allowed or permissible orbits for which the angular momentum of the electron is an integral multiple of  $\frac{h}{2\pi}$  (where  $h$  is Planck's constant =  $6.626 \times 10^{-34}$  Js). These orbits are called stationary orbits or non-radiating orbits and an electron revolving in these orbits does not radiate any energy.

If  $m$  and  $v$  are the mass and velocity of the electron in a permitted orbit of radius  $r$  then angular momentum of electron =  $mvr = \frac{nh}{2\pi}$ , where  $n$  is called principal quantum number and has the integral values 1,2,3 ... This is called Bohr's quantization condition.

(ii) An atom radiates energy, only when an electron jumps from a stationary orbit of higher energy to an orbit of lower energy. If the electron jumps from an orbit of energy  $E_2$  to an orbit of energy  $E_1$ , a photon of energy  $h\nu = E_2 - E_1$  is emitted. This condition is called Bohr's frequency condition.

### **Radius of the $n^{\text{th}}$ orbit ( $r_n$ )**

Consider an atom whose nucleus has a positive charge  $Ze$ , where  $Z$  is the atomic number that gives the number of protons in the nucleus and  $e$ , the charge of the electron which is numerically equal to that of proton. Let an electron revolve around the nucleus in the  $n^{\text{th}}$  orbit of radius  $r_n$ .

By Coulomb's law, the electrostatic force of attraction between the nucleus and the electron =  $\frac{1}{4\pi\epsilon_0} \cdot \frac{(Ze)(e)}{r_n^2}$  ... (1)

where  $\epsilon_0$  is the permittivity of the free space.

Since, the electron revolves in a circular orbit, it experiences a centripetal force,  $\frac{mv_n^2}{r_n} = mr_n\omega_n^2$  ... (2)

where  $m$  is the mass of the electron,  $v_n$  and  $\omega_n$  are the linear velocity and angular velocity of the electron in the  $n^{\text{th}}$  orbit respectively.

The necessary centripetal force is provided by the electrostatic force of attraction.

For equilibrium, from equations (1) and (2),

$$\frac{1}{4\pi\epsilon_0} \cdot \frac{Ze^2}{r_n^2} = \frac{mv_n^2}{r_n} \quad \dots(3)$$

$$\frac{1}{4\pi\epsilon_0} \cdot \frac{Ze^2}{r_n^2} = mr_n\omega_n^2 \quad \dots(4)$$

From equation (4),

$$\omega_n^2 = \frac{Ze^2}{4\pi\epsilon_0mr_n^3} \quad \dots(5)$$

The angular momentum of an electron in  $n^{\text{th}}$  orbit is,

$$L = mv_n r_n = mr_n^2\omega_n \quad \dots(6)$$

By Bohr's first postulate, the angular momentum of the electron

$$L = \frac{nh}{2\pi} \quad \dots(7)$$

where  $n$  is an integer and is called as the principal quantum number.

From equations. (6) and (7),

$$mr_n^2\omega_n = \frac{nh}{2\pi}$$

$$\text{(or)} \quad \omega_n = \frac{nh}{2\pi mr_n^2}$$

squaring both sides,

$$\omega_n^2 = \frac{n^2h^2}{4\pi^2m^2r_n^4} \quad \dots(8)$$

From equations (5) and (8),

$$\frac{Ze^2}{4\pi\epsilon_0mr_n^3} = \frac{n^2h^2}{4\pi^2m^2r_n^4}$$

$$(or) \quad r_n = \frac{n^2 h^2 \epsilon_0}{\pi m Z e^2} \quad \dots(9)$$

From equation (9), it is seen that the radius of the  $n^{\text{th}}$  orbit is proportional to the square of the principal quantum number. Therefore, the radii of the orbits are in the ratio 1 : 4 : 9....

For hydrogen atom,  $Z = 1$

$\therefore$  From equation (9)

$$r_n = \frac{n^2 h^2 \epsilon_0}{\pi m e^2} \quad \dots(10)$$

Substituting the known values in the above equation we get,

$$r_n = n^2 \times 0.53 \text{ \AA}$$

$$\text{If } n = 1, r_1 = 0.53 \text{ \AA}$$

This is called Bohr radius.

### **Energy of an electron in the $n^{\text{th}}$ orbit ( $E_n$ )**

The total energy of the electron is the sum of its potential energy and kinetic energy in its orbit (Fig 6.10).

The potential energy of the electron in the  $n^{\text{th}}$  orbit is given by,

$$E_p = \frac{(Ze)(-e)}{4\pi\epsilon_0 r_n} = \frac{-Ze^2}{4\pi\epsilon_0 r_n} \quad \dots(11)$$

The kinetic energy of the electron in the  $n^{\text{th}}$  orbit is,

$$E_k = \frac{1}{2} m v_n^2 \quad \dots(12)$$

From equation (3),

$$\frac{1}{4\pi\epsilon_0} \cdot \frac{Ze^2}{r_n} = m v_n^2 \quad \dots(13)$$

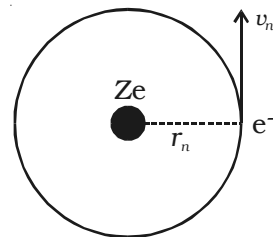

Fig 6.10 Energy of the electron

Substituting equation (13) in (12)

$$E_k = \frac{1}{2} \left[ \frac{1}{4\pi\epsilon_0} \frac{Ze^2}{r_n} \right] = \frac{Ze^2}{8\pi\epsilon_0 r_n} \quad \dots(14)$$

The total energy of an electron in its  $n^{\text{th}}$  orbit is,

$$\begin{aligned} E_n &= E_p + E_k = \frac{-Ze^2}{4\pi\epsilon_0 r_n} + \frac{Ze^2}{8\pi\epsilon_0 r_n} \\ E_n &= \frac{-Ze^2}{8\pi\epsilon_0 r_n} \quad \dots(15) \end{aligned}$$

Substituting the value of  $r_n$ , from equation (10) in equation (15),

$$E_n = \frac{-Z^2 m e^4}{8\epsilon_0^2 n^2 h^2} \quad \dots(16)$$

For hydrogen atom,  $Z = 1$

$$\therefore E_n = \frac{-m e^4}{8\epsilon_0^2 n^2 h^2}$$

Substituting the known values and calculating in electron-volt,

$$E_n = \frac{-13.6}{n^2} \text{eV} \quad \dots(17) \quad [\because 1\text{eV} = 1.602 \times 10^{-19}\text{J}]$$

As there is a negative sign in equation (17), it is seen that the energy of the electron in its orbit increases as  $n$  increases.

### **Frequency of spectral line**

According to Bohr's second postulate, when an electron jumps from an outer orbit of quantum number  $n_2$  to an inner orbit of quantum number  $n_1$ , the frequency of the photon emitted is given by,

$$\nu = \frac{E_{n_2} - E_{n_1}}{h}$$

Using equation (16)

$$\nu = \frac{Z^2 m e^4}{8\epsilon_0^2 h^3} \left( \frac{1}{n_1^2} - \frac{1}{n_2^2} \right) \quad \dots(18)$$

The wave number  $\bar{\nu}$  of a radiation is defined as number of waves per unit length. It is equal to reciprocal of the wavelength

$$\bar{\nu} = \frac{1}{\lambda} = \frac{\nu}{c} \quad [\text{since } c = \nu\lambda]$$

where c is the velocity of light

$\therefore$  From equation (18),

$$\bar{\nu} = \frac{Z^2 me^4}{8\epsilon_0^2 ch^3} \left( \frac{1}{n_1^2} - \frac{1}{n_2^2} \right) \quad \dots(19)$$

For hydrogen atom,  $Z=1$

$$\bar{\nu} = \frac{me^4}{8\epsilon_0^2 ch^3} \left( \frac{1}{n_1^2} - \frac{1}{n_2^2} \right) = R \left( \frac{1}{n_1^2} - \frac{1}{n_2^2} \right) \quad \dots(20)$$

where R is a constant called Rydberg's constant

$$\therefore R = \frac{me^4}{8\epsilon_0^2 ch^3} \quad \dots(21)$$

Substituting the known values, we get

$$R = 1.094 \times 10^7 \text{m}^{-1}$$

### 6.2.5 Spectral series of hydrogen atom

Whenever an electron in a hydrogen atom jumps from higher energy level to the lower energy level, the difference in energies of the two levels is emitted as a radiation of particular wavelength. It is called a spectral line. As the wavelength of the spectral line depends upon the two orbits (energy levels) between which the transition of electron takes place, various spectral lines are obtained. The different wavelengths constitute spectral series which are the characteristic of the atoms emitting them. The following are the spectral series of hydrogen atom.

#### (i) Lyman series

When the electron jumps from any of the outer orbits to the first orbit, the spectral lines emitted are in the ultraviolet region of the spectrum and they are said to form a series called Lyman series (Fig 6.11).

Here,  $n_1 = 1$ ,  $n_2 = 2,3,4 \dots$

The wave number of the Lyman series is given by,

$$\bar{\nu} = R \left( 1 - \frac{1}{n_2^2} \right)$$

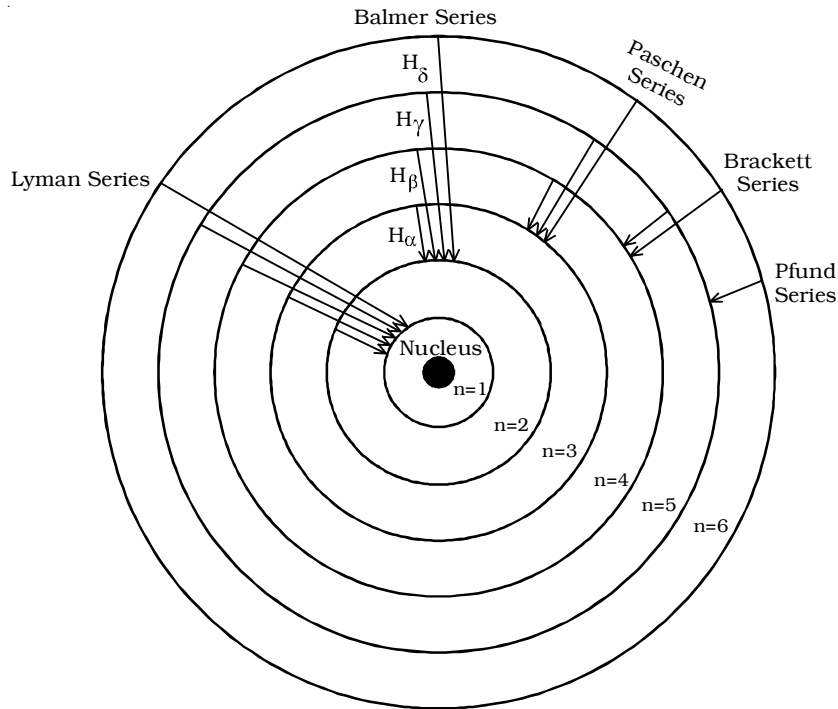

Fig 6.11 Spectral series of hydrogen atom

**(ii) Balmer series**

When the electron jumps from any of the outer orbits to the second orbit, we get a spectral series called the Balmer series. All the lines of this series in hydrogen have their wavelength in the visible region. Here  $n_1=2$ ,  $n_2 = 3,4,5 \dots$

The wave number of the Balmer series is,

$$\bar{\nu} = R \left( \frac{1}{2^2} - \frac{1}{n_2^2} \right) = R \left( \frac{1}{4} - \frac{1}{n_2^2} \right)$$

The first line in this series ( $n_2 = 3$ ), is called the H<sub>α</sub>-line, the second ( $n_2=4$ ), the H<sub>β</sub>-line and so on.

**(iii) Paschen series**

This series consists of all wavelengths which are emitted when the electron jumps from outer most orbits to the third orbit. Here  $n_2 = 4, 5, 6 \dots$  and  $n_1 = 3$ . This series is in the infrared region with the wave number given by

$$\bar{\nu} = R \left( \frac{1}{3^2} - \frac{1}{n_2^2} \right) = R \left( \frac{1}{9} - \frac{1}{n_2^2} \right)$$

**(iv) Brackett series**

The series obtained by the transition of the electron from  $n_2 = 5, 6, \dots$  to  $n_1 = 4$  is called Brackett series. The wavelengths of these lines are in the infrared region. The wave number is,

$$\bar{\nu} = R \left( \frac{1}{4^2} - \frac{1}{n_2^2} \right) = R \left( \frac{1}{16} - \frac{1}{n_2^2} \right)$$

**(v) Pfund series**

The lines of the series are obtained when the electron jumps from any state  $n_2 = 6, 7, \dots$  to  $n_1 = 5$ . This series also lies in the infrared region. The wave number is,

$$\bar{\nu} = R \left( \frac{1}{5^2} - \frac{1}{n_2^2} \right) = R \left( \frac{1}{25} - \frac{1}{n_2^2} \right)$$

**6.2.6 Energy level diagram**

The energy of the electron in the  $n^{\text{th}}$  orbit of the hydrogen atom is given by,

$$E_n = \frac{-13.6}{n^2} \text{ eV}$$

Energy associated with the first orbit of the hydrogen atom is,

$$E_1 = \frac{-13.6}{1^2} = -13.6 \text{ eV}$$

It is called ground state energy of the hydrogen atom.

Energy associated with the second orbit is given by,

$$E_2 = \frac{-13.6}{2^2} = -3.4 \text{ eV}$$



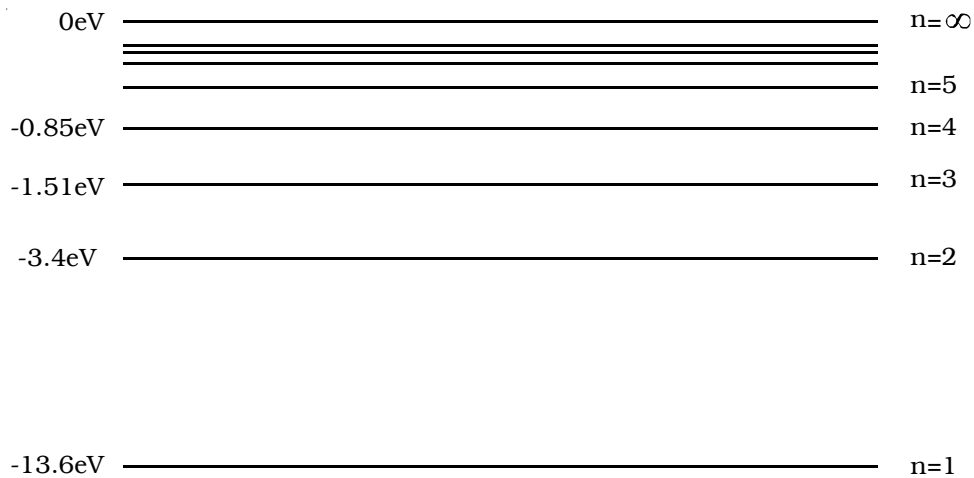

*Fig 6.12 Energy level diagram for hydrogen atom*

It is called energy of first excited state of the hydrogen atom. The energy of second, third, fourth, ... excited states of the hydrogen atom are,  $E_3 = -1.51$  eV,  $E_4 = -0.85$  eV,  $E_5 = -0.54$ eV ...

$$\text{when } n = \infty, E_{\infty} = \frac{-13.6}{\infty^2} = 0$$

Therefore, it is seen from the above values, that, the energy associated with a state becomes less negative and approaches closer and closer to the maximum value zero corresponding to  $n = \infty$ .

Taking these energies on a linear scale, horizontal lines are drawn which represent energy levels of the hydrogen atom (Fig 6.12). This diagram is known as energy level diagram.

### **6.2.7 Sodium and mercury spectra**

The sodium vapour lamp is commonly used in the laboratory as a source of monochromatic (single colour) light. Sodium vapour lamps and mercury lamps have been used for street lighting, as the two lamps give a more intense light at comparatively low cost. The mercury light is a composite light consisting of all colours in the visible spectrum. The wavelength of prominent lines emitted by the mercury source is presented in Table 6.1. The two lamps work on the principle of hot cathode positive column. Since, sodium and mercury atoms are in the

vapour state, they emit line spectra. The sodium vapour lamp emits yellow light of wavelength 5896Å and 5890Å. These lines are called sodium D<sub>1</sub> and D<sub>2</sub> lines.

**Table 6.1 Wavelength of spectral lines emitted by mercury  
(NOT FOR EXAMINATION)**

Colour	Wavelength (nm)
Violet I	398
Violet II	403
Blue	436
Bluish Green I	492
Bluish Green II	496
Green	546
Yellow I	577
Yellow II	579
Orange	609
Red	625

### 6.2.8 Excitation and ionization potential of an atom

According to Bohr's theory, there are certain discrete orbits permitted for the motion of the electron. Electron can revolve in these orbits without radiating energy. An atom is said to be in the ground state, when its energy is least. Before an atom can emit spectral radiation, the electron in it has to be raised to a higher orbit. This process is known as the excitation of the atom. The energy required to raise an atom from its normal state into an excited state is called *excitation potential energy* of the atom. For example, the energy required to transfer the electron in hydrogen atom from the ground state to the first excited state =  $(13.6 - 3.4) = 10.2\text{eV}$ . The energy required to raise it to the second excited state =  $(13.6 - 1.51) = 12.09\text{ eV}$ . The potentials corresponding to these energies are called as the excitation potentials.

The ionisation potential is that accelerating potential which makes the impinging electron acquire sufficient energy to knock out an electron from the atom and thereby ionise the atom. For hydrogen atom, the energy required to remove an electron from first orbit to its outermost orbit( $n=\infty$ )  $13.6 - 0 = 13.6\text{eV}$ . This energy is known as the ionization potential energy for hydrogen atom. 13.6 V is the ionisation potential of hydrogen atom.

The excitation potential and ionization potential are called as the critical potentials of the atom. The *critical potential* of an atom, is defined as the minimum potential required to excite a free neutral atom from its ground state to higher state.

#### **6.2.9 Shortcomings of Bohr's theory**

Bohr's theory was able to explain successfully a number of experimental observations and has correctly predicted the spectral lines of hydrogen atom. However, the theory fails in the following aspects.

(i) The theory could not account for the spectra of atoms more complex than hydrogen.

(ii) The theory does not give any information regarding the distribution and arrangement of electrons in an atom.

(iii) It does not explain, the experimentally observed variations in intensity of the spectral lines of the element.

(iv) When the spectral line of hydrogen atom is examined by spectrometers having high resolving power, it is found that a single line is composed of two or more close components. This is known as the fine structure of spectral lines. Bohr's theory could not account for the fine structure of spectral lines.

(v) It is found that when electric or magnetic field is applied to the atom, each of the spectral line split into several lines. The former effect is called as Stark effect, while the latter is known as Zeeman effect. Bohr's theory could not explain the Stark effect and Zeeman effect.

#### **6.2.10 Sommerfeld atom model**

In order to explain the observed fine structure of spectral lines, Sommerfeld introduced two main modifications in Bohr's theory.

(i) According to Sommerfeld, the path of an electron around the nucleus, in general, is an ellipse with the nucleus at one of its foci.

(ii) The velocity of the electron moving in an elliptical orbit varies at different parts of the orbit. This causes the relativistic variation in the mass of the moving electron.

Now, when elliptical orbits are permitted, one has to deal with two variable quantities.

(i) The varying distance of the electron from the nucleus ( $r$ ).

(ii) The varying angular position of the electron with respect to the nucleus i.e the azimuthal angle  $\phi$  (Fig 6.13).

To deal with these two variables, two quantum numbers are introduced

(i) The principal quantum number  $n$  of Bohr's theory, which determines the energy of the electrons, and (ii) a new quantum number called orbital (or azimuthal) quantum number ( $l$ ) which has been introduced to characterize the angular momentum in an orbit i.e., it determines the orbital angular momentum of the electron. Its values vary from zero to  $(n-1)$  in steps of unity.

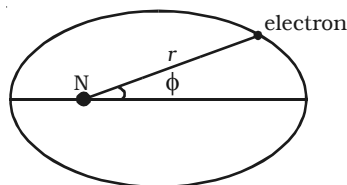

Fig 6.13 Sommerfeld atom model

This orbital quantum number ( $l$ ) is useful in finding the possible elliptical orbits. The possible elliptical orbits are such that

$$\frac{b}{a} = \frac{l+1}{n}$$

where  $a$  and  $b$  are semi-major and semi-minor axes respectively of the ellipse.

According to Sommerfeld's model, for any principal quantum number  $n$ , there are  $n$  possible orbits of varying eccentricities called sub-orbits or sub-shells. Out of  $n$  subshells, one is circular and the remaining (i.e.,  $n-1$ ) are elliptical in shape.

These possible sub-orbits possess slightly different energies because of the relativistic variation of the electron mass.

Consider the first energy level ( $n=1$ ). When  $n = 1$ ,  $l = 0$  i.e., in this energy level, there is only one orbit or sub-shell for the electron. Also, when  $a = b$ , the two axes of the ellipse are equal. As a result of this, the orbit corresponding to  $n=1$  is circular. This subshell is designated as  $s$  sub-shell. Since, this sub-shell belongs to  $n=1$ , it is designated as  $1s$  (Fig 6.14a).

Similarly, for the second energy level  $n=2$ , there are two permissible sub-shells for the electrons. For  $n=2$ ,  $l$  can take two values, 0 and 1.

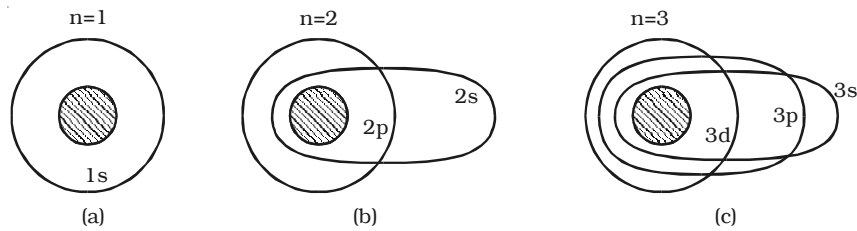

Fig 6.14 Various sub-shells for the electrons

When  $n = 2$ ,  $l = 0$ .

$$\frac{b}{a} = \frac{0+1}{2} = \frac{1}{2} \quad (\text{or}) \quad b = \frac{a}{2}$$

This subshell corresponding to  $l = 0$  is elliptical in shape and is designated as  $2s$ .

when  $n = 2$ ,  $l = 1$ .

$$\frac{b}{a} = \frac{1+1}{2} = \frac{2}{2} = 1 \quad (\text{or}) \quad b = a$$

This sub-shell corresponding to  $l = 1$  is circular in shape and is designated as  $2p$  (Fig 6.14b).

For  $n = 3$ ,  $l$  has three values 0, 1 and 2, i.e. there are three permissible sub-shells for the electrons.

when  $n = 3$ ,  $l = 0$ .

$$\frac{b}{a} = \frac{0+1}{3} = \frac{1}{3} \quad (\text{or}) \quad b = \frac{a}{3}$$

when  $n = 3$ ,  $l = 1$ .

$$\frac{b}{a} = \frac{1+1}{3} = \frac{2}{3} \quad (\text{or}) \quad b = \frac{2a}{3}$$

and when  $n = 3$ ,  $l = 2$ .

$$\frac{b}{a} = \frac{2+1}{3} = \frac{3}{3} \quad (\text{or}) \quad b = a$$

The sub-shells corresponding to  $l = 0, 1$  and  $2$  are designated as  $3s, 3p$  and  $3d$  respectively. The circular shell is designated as  $3d$  and the other two are elliptical in shape (Fig 6.14c).

It is common practice to assign letters to  $l$ -values as given below:

Orbital quantum number $l$	:	0	1	2	3	4
electron state	:	$s$	$p$	$d$	$f$	$g$

Hence, electrons in the  $l = 0, 1, 2, 3 \dots$  states are said to be in the  $s, p, d, f \dots$  states.

### ***Fine structure of spectral line***

Based on Sommerfeld atom model, the total energy of an electron in the elliptical orbit can be shown as,

$$E_n = \frac{-me^4Z^2}{8\epsilon_0^2h^2n^2}$$

This expression is the same as that obtained by Bohr. Thus the introduction of elliptical orbits gives no new energy levels and hence no new transition. In this way, the attempt of Sommerfeld to explain the fine structure of spectral lines failed. But soon, on the basis of variation of mass of electron with velocity, Sommerfeld could find the solution for the problem of the fine structure of the spectral lines.

According to Sommerfeld, the velocity of the electron is maximum when the electron is nearest to the nucleus and minimum when it is farthest from the nucleus, since the orbit of the electron is elliptical.

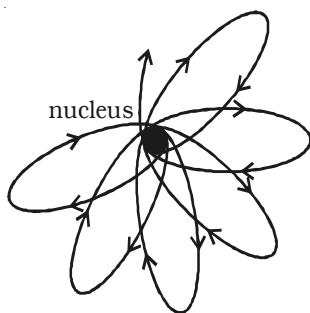

*Fig 6.15 Rosette path of an electron*

This implies that the effective mass of the electron will be different at different parts of its orbit. Taking into account the relativistic variation of the mass of the electron, Sommerfeld modified his theory and showed that the path of electron is not a simple ellipse but a precessing ellipse called a rosette (Fig 6.15).

Based on this idea, Sommerfeld successfully explained the fine structure of spectral lines of hydrogen atom.

### ***Drawbacks***

(i) Though Sommerfeld's modification gave a theoretical background of the fine structure of spectral lines of hydrogen, it could not predict the correct number of observed fine structure of these lines.

(ii) It could not explain the distribution and arrangement of electrons in atoms.

(iii) Sommerfeld's model was unable to explain the spectra of alkali metals such as sodium, potassium etc.

(iv) It could not explain Zeeman and Stark effect.

(v) This model does not give any explanation for the intensities of the spectral lines.

### 6.3. X-rays

A German scientist, Wilhelm Roentgen, in 1895, discovered X-rays when he was studying the phenomenon of discharge of electricity through gases.

After performing a series of experiments, Roentgen concluded that when a beam of fast moving electrons strike a solid target, an invisible penetrating radiation is produced. Due to the unknown nature of the radiation, Roentgen called these radiations as X - rays.

X-rays are electromagnetic waves of short wavelength in the range of  $0.5 \text{ \AA}$  to  $10 \text{ \AA}$ . Roentgen was awarded Nobel prize in 1901 for the discovery of X-rays.

#### 6.3.1 Production of X-rays - Modern Coolidge tube

X-rays are produced, when fast moving electrons strike a metal target of suitable material. The basic requirement for the production of X-rays are: (i) a source of electrons, (ii) effective means of accelerating the electrons and (iii) a target of suitable material of high atomic weight.

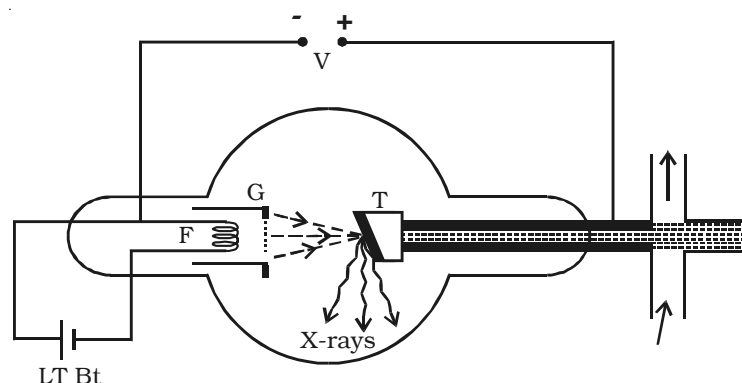

Fig 6.16 Coolidge tube

The modern type of X-ray tube designed by Coolidge is shown in Fig 6.16. It consists of a highly evacuated hard glass bulb containing a cathode and an anode target. The pressure inside the tube is  $10^{-6}$  mm of mercury. The cathode is a tungsten filament F and is heated by passing a current through it from a low tension battery. The electrons are emitted by the process of thermionic emission from the cathode. The filament is surrounded by a molybdenum cylinder G kept at a

negative potential to the filament. Hence, the electrons emitted from the filament are collimated into a fine pencil of electron beam.

The target T consists of a copper block in which a piece of tungsten or molybdenum is fixed. The anode should have the following characteristics :

(i) high atomic weight – to produce hard X-rays

(ii) high melting point – so that it is not melted due to the bombardment of fast moving electrons, which cause lot of heat generation.

(iii) high thermal conductivity – to carry away the heat generated.

The face of the copper anode is sloped at about  $45^\circ$  to the electron beam. Being good conductor of heat, copper helps to conduct the heat efficiently to the water cooling system. A high potential of about 20 kV is applied between filament F and the target T. Due to this high potential difference, the electrons emitted from the filament are accelerated. When these accelerated electrons strike the target, they give up their kinetic energy and thereby produce X-rays.

The intensity of X-rays depends upon the number of electrons striking the target. i.e. the rate of emission of electrons from the filament. This can be controlled by varying the filament current.

### **6.3.2 Soft X-rays and Hard X-rays**

X-rays are of two types : (i) Soft X-rays and (ii) Hard X-rays

#### **(i) Soft X-rays**

X-rays having wavelength of  $4\text{\AA}$  or above, have lesser frequency and hence lesser energy. They are called soft X – rays due to their low penetrating power. They are produced at comparatively low potential difference.

#### **(ii) Hard X-rays**

X-rays having low wavelength of the order of  $1\text{\AA}$  have high frequency and hence high energy. Their penetrating power is high, therefore they are called hard X-rays. They are produced at comparatively high potential difference.

The wavelength of X-rays depends upon the kinetic energy of the electrons producing them and this kinetic energy depends upon the potential difference between the filament and the target.



### **6.3.3 Properties of X-rays**

(i) X-rays are electromagnetic waves of very short wave length. They travel in straight lines with the velocity of light. They are invisible to eyes.

(ii) They undergo reflection, refraction, interference, diffraction and polarisation.

(iii) They are not deflected by electric and magnetic fields. This indicates that X-rays do not have charged particles.

(iv) They ionize the gas through which they pass.

(v) They affect photographic plates.

(vi) X-rays can penetrate through the substances which are opaque to ordinary light e.g. wood, flesh, thick paper, thin sheets of metals.

(vii) When X-rays fall on certain metals, they liberate photo electrons (Photo electric effect).

(viii) X-rays have destructive effect on living tissue. When the human body is exposed to X-rays, it causes redness of the skin, sores and serious injuries to the tissues and glands. They destroy the white corpuscles of the blood.

(ix) X-rays do not pass through heavy metals such as lead and bones. If such objects are placed in their path, they cast their shadow.

### **6.3.4 Detection of X-rays**

The basic properties which are generally used for the detection of X-rays are : (i) blackening of a photographic plate and (ii) the ionization produced by X-rays in a gas or vapour. An ionization chamber, which utilizes the property of ionization, is generally used to detect and measure the intensity of X-rays.

### **6.3.5 Absorption of X-rays**

When X-rays pass through any material, a part of the X-ray energy is absorbed by the material. If a beam of X-rays of intensity  $I$  passes through a length  $dx$  of any material, its intensity is decreased by  $dI$ . For any given material, the amount of absorbed intensity is  $\mu I dx$  where  $\mu$  is called the absorption co-efficient. i.e.,  $dI = -\mu I dx$

### 6.3.6 Diffraction of X-rays

Soon after the discovery of X-rays, Schuster pointed out that X-rays behave as electromagnetic waves of wavelength much shorter than that of visible light. Attempts were made to measure the wavelength of X-rays by means of diffraction gratings which proved unsuccessful, as the grating failed to disperse X-rays on account of their very small wavelength. Obviously, diffraction effects can only be observed if the spacing between the lines ruled on the grating is of the order of magnitude of wavelength of the wave used. Thus, in order to diffract X-rays, grating with much finer rulings, having distance between rulings comparable to the wavelength of X-rays are required. It is impossible to construct a grating of such fine dimensions artificially.

In a crystal, the atoms or molecules are arranged symmetrically in a three dimensional space. Any plane containing an arrangement of atoms is known as lattice plane or cleavage plane. The spacing between the atoms is of the order of  $10^{-10}$  m, comparable to the wavelength of X-rays. It was suggested that the regular arrangement of atoms or molecules in the cleavage planes of a crystal might provide a grating element suitable to diffract X-rays. The crystal might serve as a three dimensional grating, whereas optical grating is a two dimensional one.

### 6.3.7 Laue experiment

Von Laue, in 1913, suggested that a crystal can act as a three dimensional grating for an X-ray beam. The experimental arrangement used to produce diffraction in X-rays by Laue is shown in Fig 6.17(a). X-rays from the X-ray tube is collimated into a fine beam by two slits

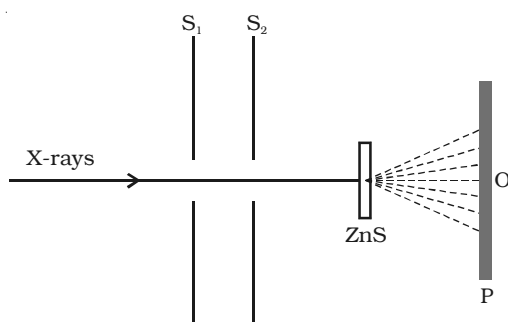

Fig 6.17 (a) Laue experimental set up

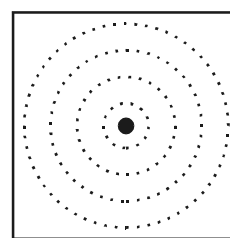

Fig 6.17 (b) Laue spot

$S_1$  and  $S_2$ . The beam is now allowed to pass through a zinc sulphide ( $ZnS$ ) crystal. The emergent rays are made to fall on a photographic plate P. The diffraction pattern so obtained consists of a central spot at O and a series of spots arranged in a definite pattern about O as shown in Fig 6.17b. The central spot is due to the direct beam, whereas the regularly arranged spots are due to the diffraction pattern from the atoms of the various crystal planes. These spots are known as Laue spots. The Laue experiment has established following two important facts :

- (i) X-rays are electro magnetic waves of extremely short wave length.
- (ii) The atoms in a crystal are arranged in a regular three dimensional lattice.

### 6.3.8 Bragg's law for X-ray diffraction

W.L. Bragg and W.H. Bragg studied the diffraction of X-rays in detail and used a crystal of rock salt to diffract X-rays and succeeded in measuring the wavelength of X-rays.

Consider homogeneous X-rays of wave length  $\lambda$  incident on a crystal at a glancing angle  $\theta$ . The incident rays AB and DE after reflection from the lattice planes Y and Z travel along BC and EF respectively as shown in Fig 6.18.

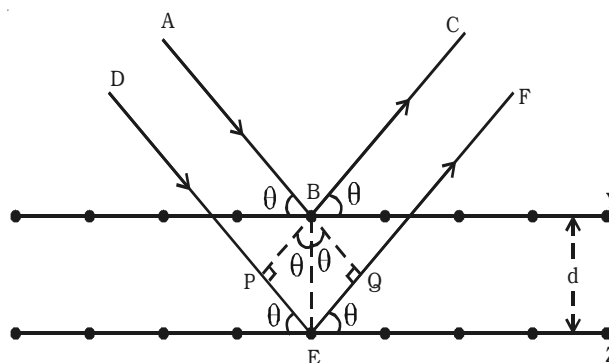

Fig 6.18 Bragg's law

Let the crystal lattice spacing between the planes be  $d$ . BP and BQ are perpendiculars drawn from B on DE and EF respectively. Therefore, the path difference between the two waves ABC and DEF is equal to  $PE + EQ$ .

$$\text{In the } \triangle PBE, \sin \theta = \frac{PE}{BE} \text{ (or) } PE = BE \sin \theta = d \sin \theta$$

In the  $\triangle QBE$ ,  $\sin \theta = \frac{EQ}{BE}$  (or)  $EQ = BE \sin \theta = d \sin \theta$

$\therefore$  Path difference =  $PE + EQ = d \sin \theta + d \sin \theta = 2d \sin \theta$

If this path difference  $2d \sin \theta$  is equal to integral multiple of wavelength of X-ray i.e.  $n\lambda$ , then constructive interference will occur between the reflected beams and they will reinforce with each other. Therefore the intensity of the reflected beam is maximum.

$\therefore 2d \sin \theta = n\lambda$

where,  $n = 1, 2, 3 \dots$  etc.

This is known as Bragg's law.

### 6.3.9 Bragg's X-ray spectrometer

Bragg's spectrometer used to determine the wavelength of X-rays is shown in Fig 6.19. Bragg's spectrometer is similar in construction to an ordinary optical spectrometer.

X-rays from an X-ray tube are made to pass through two fine slits  $S_1$  and  $S_2$  which collimate it into a fine pencil. This fine X-ray beam is then made to fall upon the crystal 'C' (usually sodium chloride crystal) mounted on the spectrometer table. This table is capable of rotation about a vertical axis and its rotation can be read on a circular graduated scale S. The reflected beam after passing through the slits  $S_3$  and  $S_4$

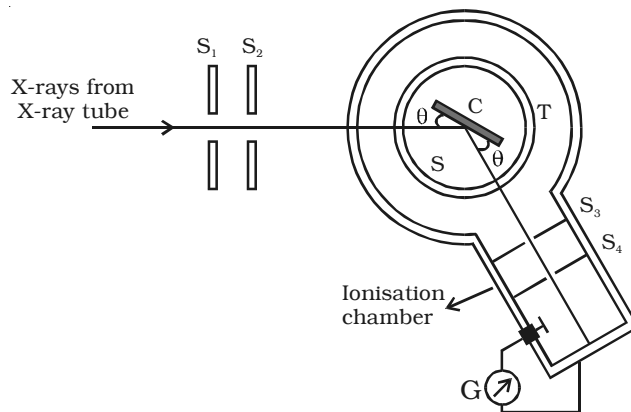

Fig 6.19 Bragg's spectrometer

enters the ionization chamber. The X-rays entering the ionization chamber ionize the gas which causes a current to flow between the electrodes and the current can be measured by galvanometer G. The ionization current is a measure of the intensity of X-rays reflected by the crystal.

The ionization current is measured for different values of glancing angle  $\theta$ . A graph is drawn between the glancing angle  $\theta$  and ionization current (Fig 6.20). For certain values of glancing angle, the ionization current increases abruptly. The

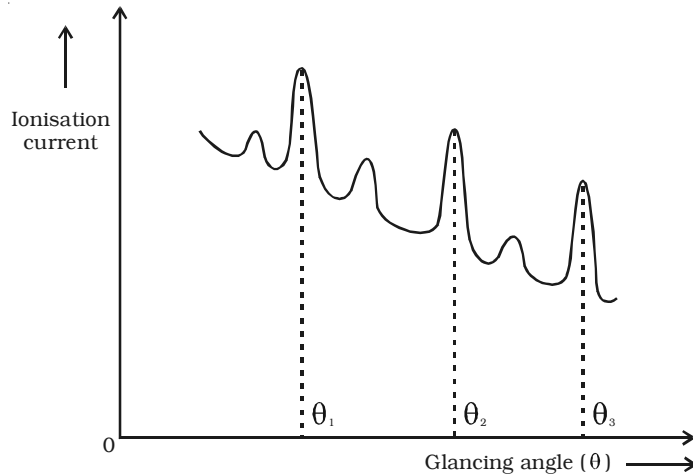

Fig 6.20 Plot of glancing angle and ionisation current

The first peak corresponds to first order, the second peak to second order and so on. From the graph, the glancing angles for different orders of reflection can be measured. Knowing the angle  $\theta$  and the spacing  $d$  for the crystal, wavelength of X-rays can be determined.

### 6.3.10 X-ray spectra - continuous and characteristic X-ray spectra.

The spectrum from an X-ray tube contains two distinct parts :

#### (i) Continuous X-ray spectra

It consists of radiations of all possible wavelengths, from a certain lower limit to higher values continuously, as in the case of visible light.

#### Origin - Continuous X-ray spectra

X-rays are produced, when high velocity electrons strike the target material of high atomic number. It has also been mentioned in the production of X-rays, that most of the energy of the electrons goes into the heating of the target material.

A few fast moving electrons penetrate deep into the interior of the atoms of the target material and are attracted towards the nuclei by the attractive forces of their nuclei. Due to these forces, the electrons get deflected from their original path. As a result of this, the electrons are decelerated, and hence energy of the electron decreases continuously. This loss of energy during retardation is given off in the form of X-rays

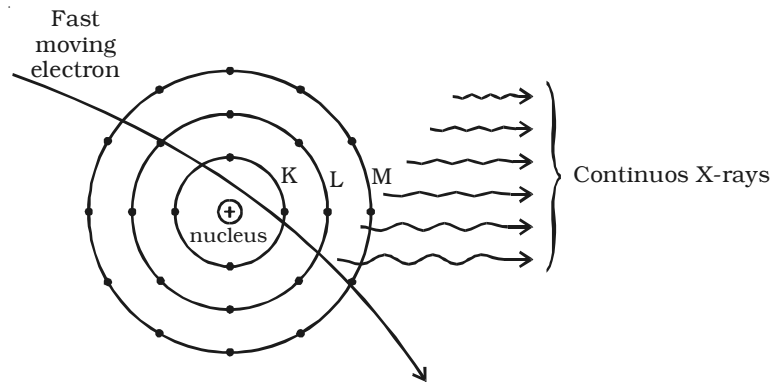

Fig 6.21 Origin of continuous X – rays

of continuously varying wavelength. The X – rays consist of continuous range of frequencies upto a maximum frequency  $\nu_{\max}$  or minimum wave length  $\lambda_{\min}$ . This is called as continuous X – rays. The minimum wave length depends on the anode voltage. If  $V$  is the potential difference between the anode and the cathode

$$eV = h\nu_{\max} = \frac{hc}{\lambda_{\min}} \quad [\because \nu = \frac{c}{\lambda}]$$

The minimum wavelength of the given radiation is,

$$\lambda_{\min} = \frac{hc}{eV}$$

where  $h$  is Planck's constant,  $c$  is the velocity of light and  $e$ , the charge of the electron. Substituting the known values in the above equation.

$$\lambda_{\min} = \frac{6.626 \times 10^{-34} \times 3 \times 10^8}{1.6 \times 10^{-19} \times V} = \frac{12400}{V} \text{ \AA}$$

For the given operating voltage, the minimum wave length is same for all metals.

### (ii) Characteristic X-ray spectra

It consists of definite, well defined wavelengths superimposed on the continuous spectrum. These spectral lines generally occur in the form of small groups and are characteristic of the material of the target.

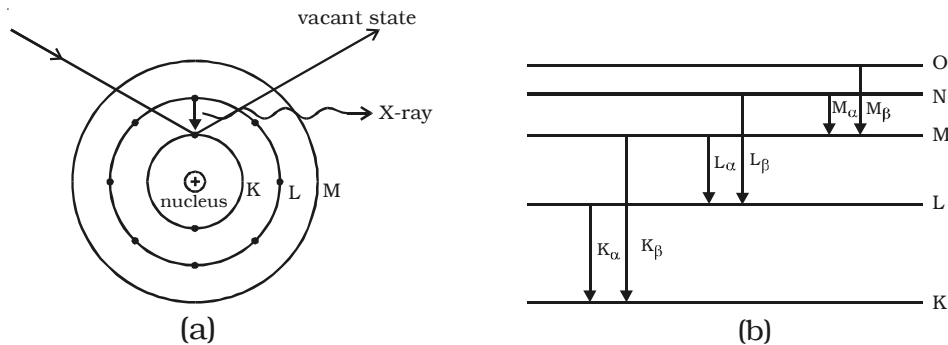

Fig 6.22 Characteristic X-ray spectra

### Origin – Characteristic X-ray spectra

Few of the fast moving electrons having velocity of about  $(1/10)^{\text{th}}$  of the velocity of light may penetrate the surface atoms of the target materials and knock out the tightly bound electrons even from the inner most shells (like K, L shells) of the atom. Fig 6.22a shows the case, when the fast moving electrons knock off one electron from K-Shell and the vacancy is filled by the nearby electron from the L shell. During this transition, the energy difference is radiated in the form of X-rays of very small wave length. This corresponds to  $K_{\alpha}$  – line of the series. The frequency  $\nu_1$  of this line is given by the relation  $(E_K - E_L) = h\nu_1$ . Suppose, the electron from M shell jumps to the K shell, it gives out  $K_{\beta}$  line and so on. If an electron jumps from the M-Shell to the vacant state in L-Shell, it contributes  $L_{\alpha}$  line and if the vacancy in L-Shell is filled up by an electron of N shell, it contributes  $L_{\beta}$  and so on (Fig 6.22b). The frequency of radiation depends upon the target material. The X-ray spectra consists of sharp lines and is the characteristic of target material. Hence this spectra is known as characteristic spectra.

#### 6.3.11 Moseley's law

Moseley investigated systematically, the characteristic radiations emitted by different targets. Based on his experiments, he has concluded that the frequency of the spectral line in the characteristic X-ray spectrum is directly proportional to the square of the atomic number ( $Z$ ) of the element considered. This is known as Moseley's law.

$$\text{i.e } \nu \propto Z^2 \quad \text{or} \quad \sqrt{\nu} = a(Z - b)$$

where  $a$  and  $b$  are constants depending upon the particular spectral line.

### ***Applications of Moseley's law***

(i) Any discrepancy in the order of the elements in the periodic table can be removed by Moseley's law by arranging the elements according to the atomic numbers and not according to the atomic weights.

(ii) Moseley's law has led to the discovery of new elements like hafnium (72), technetium (43), rhenium (75) etc.

(iii) This law has been helpful in determining the atomic number of rare earths, thereby fixing their position in the periodic table.

### ***6.3.12 Applications of X-rays***

X-rays have a number of applications. Some of them are listed below:

#### ***Medical applications***

(i) X-rays are being widely used for detecting fractures, tumours, the presence of foreign matter like bullet etc., in the human body.

(ii) X-rays are also used for the diagnosis of tuberculosis, stones in kidneys, gall bladder etc.

(iii) Many types of skin diseases, malignant sores, cancer and tumours have been cured by controlled exposure of X-rays of suitable quality.

(iv) Hard X-rays are used to destroy tumours very deep inside the body.

#### ***Industrial applications***

(i) X-rays are used to detect the defects or flaws within a material

(ii) X-rays can be used for testing the homogeneity of welded joints, insulating materials etc.

(iii) X-rays are used to analyse the structure of alloys and the other composite bodies.

(iv) X-rays are also used to study the structure of materials like rubber, cellulose, plastic fibres etc.

#### ***Scientific research***

(i) X-rays are used for studying the structure of crystalline solids and alloys.



(ii) X-rays are used for the identification of chemical elements including determination of their atomic numbers.

(iii) X-rays can be used for analyzing the structure of complex molecules by examining their X-ray diffraction pattern.

## 6.4 Laser

The light emitted from an ordinary light source is incoherent, because the radiation emitted from different atoms has no definite phase relationship with each other. For interference of light, coherent sources are essential. Two independent sources cannot act as coherent sources. For experimental purposes, from a single source, two coherent sources are obtained. In recent years, some sources have been developed, which are highly coherent known as LASER. The word 'Laser' is an acronym for Light Amplification by Stimulated Emission of Radiation. The difference between ordinary light and laser beam is pictorially depicted in Fig 6.23.

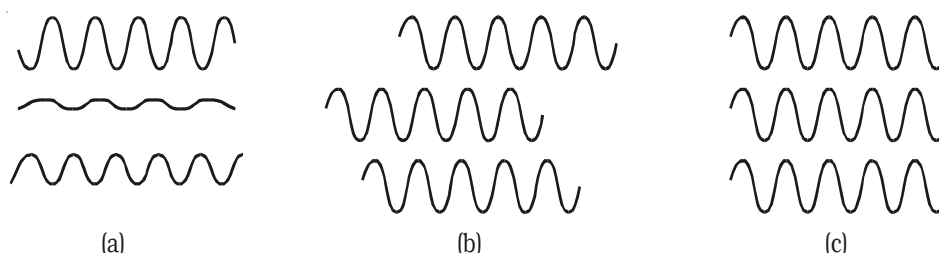

Fig 6.23 Wave forms from (a) ordinary light source  
(b) monochromatic source and (c) laser source

### 6.4.1 Characteristics of laser

The laser beam (i) is monochromatic. (ii) is coherent, with the waves, all exactly in phase with one another, (iii) does not diverge at all and (iv) is extremely intense

### 6.4.2 Spontaneous and stimulated emission

An atom may undergo transition between two energy states  $E_1$  and  $E_2$ , if it emits or absorbs a photon of the appropriate energy  $E_2 - E_1 = h\nu$ .

In a system of thermal equilibrium, the number of atoms in the ground state ( $N_1$ ) is greater than the number of atoms in the excited state ( $N_2$ ). This is called normal population (Fig 6.24). Consider a sample of free atoms, some of which are

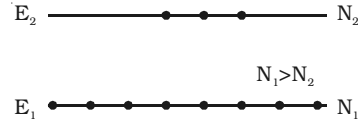
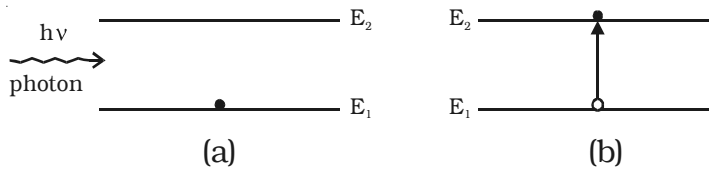

Fig 6.24 Normal population

in the ground state with energy  $E_1$  and some in the excited energy state with energy  $E_2$ . If photons of energy  $h\nu = E_2 - E_1$  are incident on the sample, the photons can interact with the atoms in the ground state and are taken to excited state. This is called stimulated or induced absorption (Fig 6.25). The process by which the atoms in the ground



state is taken to the excited state is known as pumping.

Fig 6.25 Stimulated or induced absorption

If the atoms are taken

to the higher energy levels with the help of light, it is called optical pumping. If the atoms in the ground state are pumped to the excited state by means of external agency, the number of atoms in the excited state ( $N_2$ ) becomes greater than the number of atoms in the ground state ( $N_1$ ). This is called population inversion (Fig 6.26).

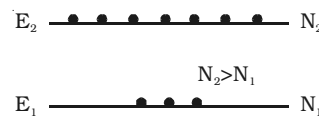

Fig 6.26 Population inversion

The life time of atoms in the excited state is normally  $10^{-8}$  second. Some of the excited energy levels have greater life times for atoms ( $10^{-3}$ s). Such energy levels are called as the metastable states. If the excited energy level is an ordinary level, the excited atoms return to the lower (or) ground energy state immediately without the help of any external agency. During this transition (Fig 6.27), a photon of energy  $E_2 - E_1 = h\nu$  is emitted. This is called spontaneous emission.

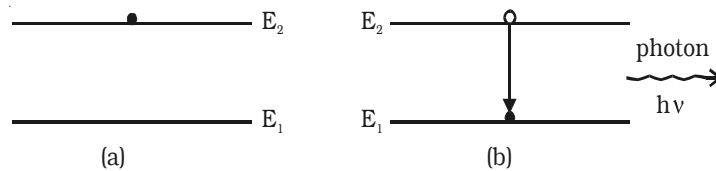

Fig 6.27 Spontaneous emission

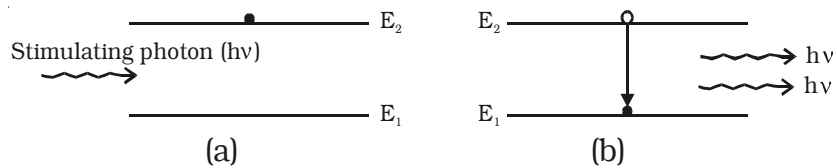

Fig 6.28 Stimulated emission

If the excited state is a metastable state, the atoms stay for some time in these levels. The atoms in such metastable state can be brought to the lower energy levels with the help of photons of energy  $h\nu = E_2 - E_1$ . During this process, a photon of energy  $E_2 - E_1 = h\nu$  is emitted. This is known as stimulated emission (or) induced emission (Fig 6.28). A photon produced by stimulated emission is called secondary photon (or) stimulated photon. The secondary photon is always in phase with the stimulating photon. These photons in turn stimulate the emission further and the process continues to give a chain - reaction. This is called laser action and by this action all the emitted photons having same energy and same frequency are in phase with each other. Hence, a highly monochromatic, perfectly coherent, intense radiation is obtained in laser.

#### **Conditions to achieve laser action**

- (i) There must be an inverted population i.e. more atoms in the excited state than in the ground state.
- (ii) The excited state must be a metastable state.
- (iii) The emitted photons must stimulate further emission. This is achieved by the use of the reflecting mirrors at the ends of the system.

#### **6.4.3 Ruby laser**

The Ruby laser was first developed by T.Maiman in 1960. It consists of a single crystal of ruby rod of length 10 cm and 0.8 cm in diameter. A ruby is a crystal of aluminium oxide  $Al_2O_3$ , in which some of aluminium ions ( $Al^{3+}$ ) are replaced by the chromium ions ( $Cr^{3+}$ ). The opposite ends of ruby rod are flat and parallel; one end is fully silvered and the other is partially silvered (i.e.) semi transparent. The ruby rod is surrounded by a helical xenon flash tube which provides the pumping light to raise the chromium ions to upper energy level (Fig 6.29). In the xenon flash tube, each flash lasts several milliseconds and in each flash a few thousand joules of energy is consumed.

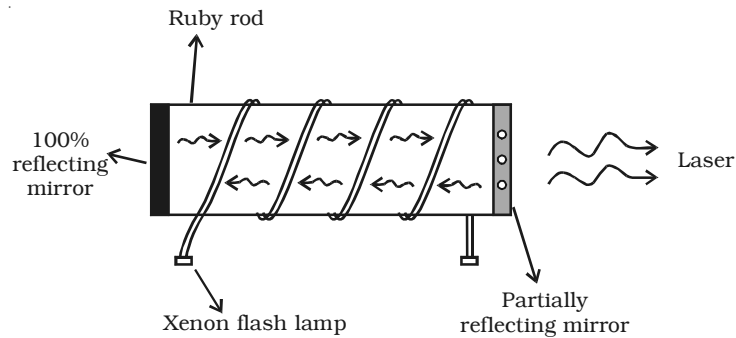

Fig 6.29 Ruby laser

The simplified energy level diagram of chromium ions in a ruby laser, indicating appropriate excitation and decay is shown in Fig 6.30. In normal state, most of the chromium ions are in the ground state  $E_1$ . When the ruby rod is irradiated by a flash of light, the  $5500 \text{ \AA}$  radiation (green colour) photons are absorbed by the chromium ions which are

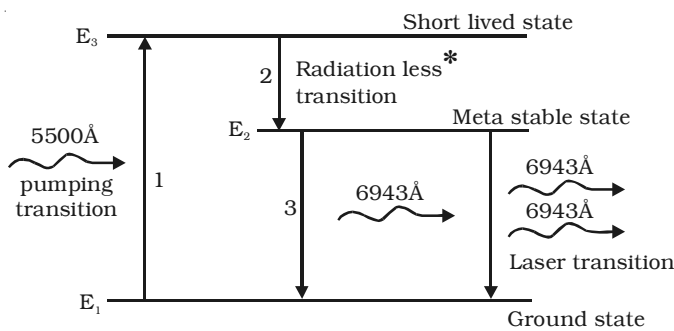

Fig 6.30 Energy level diagram for ruby laser

pumped to the excited state  $E_3$ . The excited ion gives up part of its energy to the crystal lattice and decay without giving any radiation to the meta stable state  $E_2$ . Since, the state  $E_2$  has a

much longer lifetime ( $10^{-3}$ s), the number of ions in this state goes on increasing. Thus population inversion is achieved between the states  $E_2$  and  $E_1$ . When the excited ion from the metastable state  $E_2$  drops down spontaneously to the ground state  $E_1$ , it emits a photon of wavelength  $6943 \text{ \AA}$ . This photon travels through the ruby rod and is reflected back and forth by the silvered ends until it stimulates other excited ion and causes it to emit a fresh photon in phase with stimulating photon. Thus the reflections will amount to the additional stimulated emission – the so called amplification by stimulated

\* In this process, radiation emitted, is used to heat up the system, hence no radiation comes out of the system.

emission. This stimulated emission is the laser transition. Finally, a pulse of red light of wave length  $6943 \text{ \AA}$  emerges through the partially silvered end of the crystal.

#### 6.4.4. Helium - neon laser

A continuous and intense laser beam can be produced with the help of gas lasers.

A simplified diagram showing basic features of a He - Ne gas laser is shown in Fig 6.31.

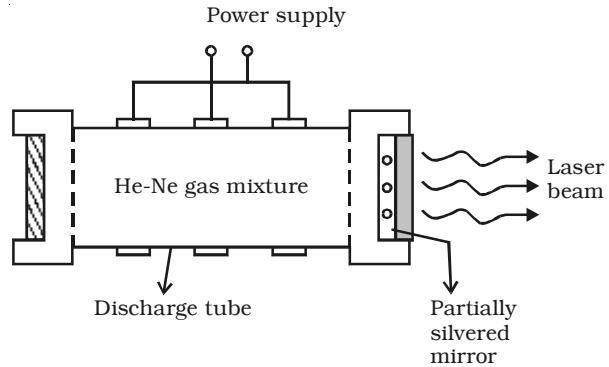

Fig 6.31 He - Ne laser

He - Ne laser system consists of a quartz discharge tube containing helium and neon in the ratio of 1 : 4 at a total pressure of about 1 mm of Hg. One end of the tube is fitted with a perfectly reflecting mirror and the other end with partially reflecting mirror.

A powerful radio frequency generator is used to produce a discharge in the gas, so that the helium atoms are excited to a higher energy level.

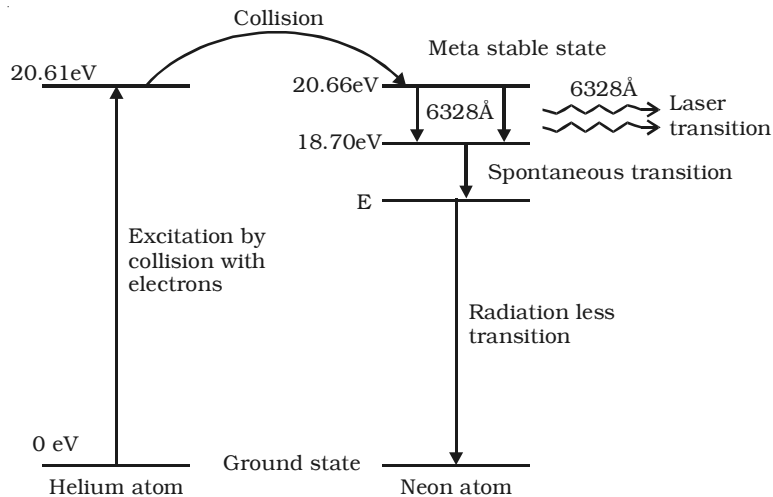

Fig 6.32 Energy level diagram for He-Ne laser system

The energy level diagram for *He* and *Ne* atoms are shown in Fig 6.32. When an electric discharge passes through the gas, the electron in the discharge tube collide with the *He* and *Ne* atoms and excite them to metastable states of energy 20.61 eV and 20.66 eV respectively above the ground state. Some of the excited helium atoms transfer their energy to unexcited Ne atoms by collision. Thus, He atom help in achieving a population inversion in Ne atoms. When an excited Ne atom drops down spontaneously from the metastable state at 20.66 eV to lower energy state at 18.70 eV, it emits a 6328 Å photon in the visible region. This photon travelling through the mixture of the gas, is reflected back and forth by the reflector ends, until it stimulates an excited neon atom and causes it to emit a fresh 6328 Å photon in phase with the stimulating photon. This stimulated transition from 20.66 eV level to 18.70 eV level is the laser transition. The output radiations escape from the partially reflecting mirror. The neon atoms drop down from the 18.70 eV level to lower state E, through spontaneous emission emitting incoherent light. From this level E, the Ne atoms are brought to the ground state through collision with the walls of the tube. Hence the final transition is radiationless.

#### **6.4.5 Applications of laser**

Due to high coherence, high intensity, laser beams have wide applications in various branches of science and engineering.

##### **Industrial applications**

- (i) The laser beam is used to drill extremely fine holes in diamonds, hard sheets etc.,
- (ii) They are also used for cutting thick sheets of hard metals and welding.
- (iii) The laser beam is used to vapourize the unwanted material during the manufacture of electronic circuit on semiconductor chips.
- (iv) They can be used to test the quality of the materials.

##### **Medical applications**

- (i) In medicine, micro surgery has become possible due to narrow angular spread of the laser beam.
- (ii) It can be used in the treatment of kidney stone, tumour, in cutting and sealing the small blood vessels in brain surgery and retina detachment.
- (iii) The laser beams are used in endoscopy.
- (iv) It can also be used for the treatment of human and animal cancer.

### **Scientific and Engineering applications**

(i) Since the laser beam can stay on at a single frequency, it can be modulated to transmit large number of messages at a time in radio, television and telephone.

(ii) The semiconductor laser is the best light source for optical fiber communication.

(iii) Narrow angular spread of the laser beam makes it a very useful tool for microwave communication. Communication with earth satellites and in rocketry. Laser is also used in accurate range finders for detecting the targets.

(iv) The earth-moon distance has been measured with the help of lasers.

(v) It is used in laser Raman Spectroscopy.

(vi) Laser is also used in holography (three dimensional lensless photography)

(vii) Laser beam can determine precisely the distance, velocity and direction as well as the size and form of the objects by means of the reflected signal as in radar.

### **Holography**

When an object is photographed by a camera, a two dimensional image of three dimensional object is obtained. A three dimensional image of an object can be formed by holography. In ordinary photography, the amplitude of the light wave is recorded on the photographic film. In holography, both the phase and amplitude of the light waves are recorded on the film. The resulting photograph is called hologram.

### **6.4.6 MASER**

The term MASER stands for Microwave Amplification by Stimulated Emission of Radiation. The working of maser is similar to that of laser. The maser action is based on the principle of population inversion followed by stimulated emission. In maser, the emitted photon, during the transition from the metastable state belongs to the microwave frequencies. The paramagnetic ions are used as maser materials. Practical maser materials are often chromium or gadolinium ions doped as impurities in ionic crystals. Ammonia gas is also a maser material. Maser provides a very strong tool for analysis in molecular spectroscopy.

### Solved Problems

- 6.1 A beam of electrons moving with a uniform speed of  $4 \times 10^7 \text{ ms}^{-1}$  is projected normal to the uniform magnetic field where  $B = 1 \times 10^{-3} \text{ Wb/m}^2$ . What is the path of the beam in magnetic field?

**Data :**  $v = 4 \times 10^7 \text{ ms}^{-1}$   
 $B = 1 \times 10^{-3} \text{ Wb/m}^2$   
path of the electron,  $r = ?$

**Solution :** Since, the electrons are released normally to the magnetic field, the electrons travel in a circular path.

$$\therefore Bev = \frac{mv^2}{r} \quad (\text{or}) \quad r = \frac{mv}{Be}$$
$$r = \frac{9.1 \times 10^{-31} \times 4 \times 10^7}{1 \times 10^{-3} \times 1.6 \times 10^{-19}}$$
$$r = 0.2275 \text{ m.}$$

- 6.2 In Thomson's experiment for the measurement of  $\left(\frac{e}{m}\right)$  of an electron, the beam remains undeflected, when the electric field is  $E = 10^5 \text{ V/m}$  and the magnetic field is  $B = 10^{-2} \text{ tesla}$ . The beam was originally accelerated through a potential difference of 285 volt. Calculate the value of the specific charge  $\left(\frac{e}{m}\right)$  of the electron.

**Data :**  $E = 10^5 \text{ Vm}^{-1}$ ,  $B = 10^{-2} \text{ tesla}$ ,  $V = 285 \text{ volt}$ ,  $\frac{e}{m} = ?$

**Solution :** The energy of the electron =  $eV$

$$\text{The kinetic energy of the electron} = \frac{1}{2} mv^2$$

$$\therefore eV = \frac{1}{2} mv^2 \quad (\text{or}) \quad \frac{e}{m} = \frac{v^2}{2V}$$

But, under the action of crossed electric and magnetic fields,



$$Bev = Ee \text{ (or) } v = \frac{E}{B}$$

$$\therefore \frac{e}{m} = \frac{E^2}{2B^2V} = \frac{(10^5)^2}{2 \times (10^{-2})^2 \times 285}$$

$$\frac{e}{m} = 1.754 \times 10^{11} \text{ C kg}^{-1}$$

- 6.3 In Millikan's experiment, an oil drop of mass  $4.9 \times 10^{-14} \text{ kg}$  is balanced by applying a potential difference of 2 kV between the two plates which are 8 mm apart. Calculate the number of elementary charges on the drop. Take  $g = 10 \text{ ms}^{-2}$ .

**Data :**  $m = 4.9 \times 10^{-14} \text{ kg}$ ;  $V = 2 \text{ kV} = 2 \times 10^3 \text{ V}$ ;

$d = 8 \text{ mm} = 8 \times 10^{-3} \text{ m}$ ;  $g = 10 \text{ ms}^{-2}$ ;

$n = \text{number of elementary charges on the drop} = ?$

**Solution :**  $Eq = mg$  (or)  $q = \frac{mg}{E}$

But  $E = \frac{V}{d}$

$$\therefore q = \frac{mg}{(V/d)} = \frac{mgd}{V} = \frac{4.9 \times 10^{-14} \times 10 \times 8 \times 10^{-3}}{2 \times 10^3}$$

$$q = 1.96 \times 10^{-18} \text{ C}$$

But  $q = ne$

$$\therefore n = \frac{q}{e} = \frac{1.96 \times 10^{-18}}{1.6 \times 10^{-19}} = 12.25 \approx 12$$

- 6.4 An  $\alpha$  - particle is projected with an energy of 4 MeV directly towards a gold nucleus. Calculate the distance of its closest approach. Given : atomic number of gold = 79 and atomic number of  $\alpha$  particle = 2.

**Data :** energy of the  $\alpha$  - particle = 4 MeV =  $4 \times 10^6 \text{ eV}$

$$= 4 \times 10^6 \times 1.6 \times 10^{-19} \text{ J}$$

$$E_K = 6.4 \times 10^{-13} \text{ J.}$$

$$Z = 79, r_o = ?$$

$$\text{Solution : } r_o = \frac{2Ze^2}{4\pi\epsilon_o E_K} = \frac{2 \times 79 \times (1.6 \times 10^{-19})^2 \times 9 \times 10^9}{6.4 \times 10^{-13}}$$

$$r_o = 5.688 \times 10^{-14} \text{ m.}$$

6.5 Wavelength of Balmer first line is 6563Å. Calculate the wavelength of second line.

**Data :** For Balmer I line,  $n_1 = 2, n_2 = 3, \lambda_1 = 6563\text{Å}$

For Balmer II line,  $n_1 = 2, n_2 = 4, \lambda_2 = ?$

**Solution :** For Balmer I line,

$$\frac{1}{\lambda_1} = R \left[ \frac{1}{n_1^2} - \frac{1}{n_2^2} \right]$$

$$\frac{1}{\lambda_1} = R \left[ \frac{1}{2^2} - \frac{1}{3^2} \right] = R \left[ \frac{5}{36} \right] \quad \dots(1)$$

For Balmer II line,

$$\frac{1}{\lambda_2} = R \left[ \frac{1}{2^2} - \frac{1}{4^2} \right] = \frac{3}{16} R \quad \dots(2)$$

Dividing equation (1) by equation (2),

$$\frac{\lambda_2}{\lambda_1} = \frac{R(5/36)}{R(3/16)} = \frac{5}{36} \times \frac{16}{3} = \frac{20}{27}$$

$$\text{(or) } \lambda_2 = \lambda_1 \cdot \left( \frac{20}{27} \right) = 6563 \times \frac{20}{27} = 4861 \text{ Å}$$

6.6 On the basis of Bohr's theory, calculate the velocity and time period of revolution of the electron in the innermost orbit ( $n=1$ ) of the hydrogen atom. Given : Bohr's Radius ( $r_1$ ) = 0.53Å.

**Data :**  $n = 1, r_1 = 0.53\text{Å} = 0.53 \times 10^{-10} \text{ m}$

$v = ?, T = ?$

$$\text{Solution : Kinetic energy of the electron} = \frac{1}{2} m v_n^2 = \frac{Z e^2}{8\pi\epsilon_o r_n}$$

$$\frac{1}{2} m v_n^2 = \frac{Z e^2}{8 \pi \epsilon_0 \left[ \frac{n^2 h^2 \epsilon_0}{\pi m Z e^2} \right]} \quad \left[ \because r_n = \frac{n^2 h^2 \epsilon_0}{\pi m Z e^2} \right]$$

$$\text{(or)} \quad v_n = \frac{Z e^2}{2 \epsilon_0 n h}$$

For hydrogen atom  $Z = 1$  and for  $n = 1$ ,

$$\begin{aligned} v_1 &= \frac{e^2}{2 \epsilon_0 h} = \frac{(1.6 \times 10^{-19})^2}{2 \times 8.854 \times 10^{-12} \times 6.626 \times 10^{-34}} \\ &= 2.1818 \times 10^6 \text{ ms}^{-1} \end{aligned}$$

(Note: Velocity can also be calculated using Bohr's first postulate)

$$\text{Period} = \text{Time taken for one revolution} = T = \frac{2 \pi r_1}{v_1}$$

$$\therefore T = \frac{2 \times 3.142 \times 0.53 \times 10^{-10}}{2.1818 \times 10^6} \quad \left[ \because \text{time} = \frac{\text{distance}}{\text{velocity}} \right]$$

$$T = 1.5265 \times 10^{-16} \text{ s}$$

6.7 The Rydberg constant for hydrogen is  $1.097 \times 10^7 \text{ ms}^{-1}$ . Calculate the short and long wavelength limits of Lyman series.

**Data :**  $R = 1.097 \times 10^7 \text{ m}^{-1}$

For short wavelength limit of Lyman Series,

$$n_1 = 1, n_2 = \infty, \lambda_s = ?$$

For long wavelength limit of Lyman series,

$$n_1 = 1, n_2 = 2, \lambda_l = ?$$

**Solution:** The wave number for Lyman series is,

$$\bar{\nu} = R \left[ \frac{1}{n_1^2} - \frac{1}{n_2^2} \right]$$

For short wavelength limit,

$$\bar{\nu}_s = \frac{1}{\lambda_s} = R \left[ \frac{1}{1^2} - \frac{1}{(\infty)^2} \right] = R$$

$$\text{(or)} \quad \lambda_s = \frac{1}{R} = \frac{1}{1.097 \times 10^7} = 911.6 \text{ \AA}$$

For long wavelength limit,

$$\frac{1}{\lambda_l} = \frac{1}{\lambda_1} = R \left[ \frac{1}{1^2} - \frac{1}{2^2} \right] = \frac{3}{4} R$$

$$\lambda_l = \frac{4}{3R} = \frac{4}{3 \times 1.097 \times 10^7}$$

$$\lambda_l = 1215 \text{ \AA}$$

- 6.8 In Bragg's spectrometer, the glancing angle for first order spectrum was observed to be  $8^\circ$ . Calculate the wavelength of X-ray, if  $d = 2.82 \times 10^{-10}$  m. At what angle will the second maximum occur?

**Data :** For  $n = 1$ ,  $\theta_1 = 8^\circ$ ;  $d = 2.82 \times 10^{-10}$  m;  $\lambda = ?$

For  $n = 2$ ,  $\theta_2 = ?$

**Solution :** When  $n = 1$ ,  $2d \sin \theta_1 = (1) \lambda$

$$\text{(or)} \quad \lambda = 2 \times 2.82 \times 10^{-10} \times \sin 8^\circ = 0.7849 \text{ \AA}$$

When  $n = 2$ ,  $2d \sin \theta_2 = (2) \lambda$

$$\sin \theta_2 = \frac{\lambda}{d} = \frac{0.7849 \times 10^{-10}}{2.82 \times 10^{-10}} = 0.2783$$

$$\theta_2 = \sin^{-1} (0.2783) = 16^\circ 9'$$

- 6.9 Calculate the longest wavelength that can be analysed by a rock salt crystal of spacing  $d = 2.82 \text{ \AA}$  in the first order.

**Data :**  $d = 2.82 \text{ \AA} = 2.82 \times 10^{-10}$  m ;  $n = 1$  ;  $\lambda_{\max} = ?$

**Solution :** For longest wavelength,  $(\sin \theta)_{\max} = 1$

$$\therefore 2d (\sin \theta)_{\max} = \lambda_{\max}$$

$$\text{(or)} \quad \lambda_{\max} = \frac{2 \times 2.82 \times 10^{-10} \times 1}{1}$$

$$\lambda_{\max} = 5.64 \times 10^{-10} \text{ m}$$

6.10 Monochromatic X-ray of wavelength  $1\text{\AA}$ , when falls on a crystal, successive reflections take place at angles  $30^\circ$  and  $45^\circ$  respectively. Find the lattice constant of the crystal.

**Data :**  $\theta_1 = 30^\circ$ ;  $\theta_2 = 45^\circ$ ;  $\lambda = 1\text{\AA}$ ;  $d = ?$

**Solution :**

$$n\lambda = 2d \sin \theta_1 \quad \dots(1)$$

$$(n+1)\lambda = 2d \sin \theta_2 \quad \dots(2)$$

equation (2) - equation (1)

$$\lambda = 2d (\sin \theta_2 - \sin \theta_1)$$

$$\therefore d = \frac{\lambda}{2(\sin \theta_2 - \sin \theta_1)} = \frac{1 \times 10^{-10}}{2(\sin 45^\circ - \sin 30^\circ)}$$

$$= \frac{1}{2\left(\frac{1}{\sqrt{2}} - \frac{1}{2}\right)} = \frac{1}{\sqrt{2} - 1} = 0.414$$

$$\therefore d = 2.415 \text{\AA}$$

6.11 Hydrogen atom in its ground state is excited by means of a monochromatic radiation of wavelength  $970.6 \text{\AA}$ . How many different transitions are possible in the resulting emission spectrum? Find the longest wavelength amongst these. (Ionisation energy of hydrogen atom in its ground state is  $13.6 \text{ eV}$  and take  $h = 6.6 \times 10^{-34} \text{ Js}$ )

**Data :** Wavelength of incident radiation =  $970.6 \text{\AA} = 970.6 \times 10^{-10} \text{ m}$

Ionisation energy of hydrogen atom in its ground state =  $13.6 \text{ eV}$

(i) number of possible transitions = ?

(ii) longest wavelength emitted = ?

**Solution :** Energy of the excited state,

$$E = \frac{hc}{\lambda} = \frac{6.6 \times 10^{-34} \times 3 \times 10^8}{970.6 \times 10^{-10} \times 1.6 \times 10^{-19}} = 12.75 \text{ eV}$$

$$E_n = -13.6 + 12.75 = -0.85 \text{ eV}$$

$$E_n = \frac{-13.6}{n^2}$$

$$\text{or } n^2 = \frac{-13.6}{E_n} = \frac{-13.6}{-0.85} = 16$$

$$\text{or } n = 4$$

The number of possible transitions in going to the lower state and hence the number of different wavelengths in the spectrum will be six (shown in the figure)

The longest wavelength corresponds to minimum energy difference, (ie for transition  $4 \rightarrow 3$ )

$$E_3 = \frac{-13.6}{3^2} = -1.51 \text{ eV}$$

$$\frac{hc}{\lambda_{\max}} = E_4 - E_3$$

$$\begin{aligned} \text{or } \lambda_{\max} &= \frac{6.6 \times 10^{-34} \times 3 \times 10^8}{(1.51 - 0.85) \times 1.6 \times 10^{-19}} \\ &= 18.75 \times 10^{-7} \text{ m} \\ \lambda_{\max} &= 18750 \text{ \AA} \end{aligned}$$

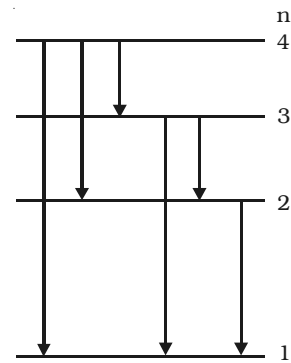

### Self evaluation

*(The questions and problems given in this self evaluation are only samples. In the same way any question and problem could be framed from the text matter. Students must be prepared to answer any question and problem from the text matter, not only from the self evaluation.)*

- 6.1 The cathode rays are  
(a) a stream of electrons (b) a stream of positive ions  
(c) a stream of uncharged particles (d) the same as canal rays
- 6.2 A narrow electron beam passes undeviated through an electric field  $E = 3 \times 10^4$  V/m and an overlapping magnetic field  $B = 2 \times 10^{-3}$  Wb/m<sup>2</sup>. The electron motion, electric field and magnetic field are mutually perpendicular. The speed of the electron is  
(a)  $60 \text{ ms}^{-1}$  (b)  $10.3 \times 10^7 \text{ ms}^{-1}$   
(c)  $1.5 \times 10^7 \text{ ms}^{-1}$  (d)  $0.67 \times 10^{-7} \text{ ms}^{-1}$
- 6.3 According to Bohr's postulates, which of the following quantities take discrete values?  
(a) kinetic energy (b) potential energy  
(c) angular momentum (d) momentum
- 6.4 The ratio of the radii of the first three Bohr orbit is,  
(a)  $1 : 1/2 : 1/3$  (b)  $1 : 2 : 3$   
(c)  $1 : 4 : 9$  (d)  $1 : 8 : 27$
- 6.5 The first excitation potential energy or the minimum energy required to excite the atom from ground state of hydrogen atom is,  
(a) 13.6 eV (b) 10.2eV  
(c) 3.4 eV (d) 1.89 eV
- 6.6 According to Rutherford atom model, the spectral lines emitted by an atom is,  
(a) line spectrum (b) continuous spectrum  
(c) continuous absorption spectrum (d) band spectrum
- 6.7 Energy levels A, B, C of a certain atom correspond to increasing values of energy (i.e.,)  $E_A < E_B < E_C$ . If  $\lambda_1, \lambda_2, \lambda_3$  are the wavelengths of radiations corresponding to the transitions C to B, B to A and C to A respectively, which of the following statements is correct.

- (a)  $\lambda_3 = \lambda_1 + \lambda_2$   
 (b)  $\lambda_3 = \frac{\lambda_1 \lambda_2}{\lambda_1 + \lambda_2}$   
 (c)  $\lambda_1 = \lambda_2 + \lambda_3 = 0$   
 (d)  $\lambda^2_3 = \lambda^2_1 + \lambda^2_2$

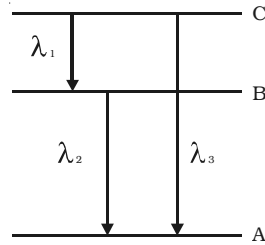

- 6.8 The elliptical orbits of electron in the atom were proposed by  
 (a) J.J.Thomson (b) Bohr  
 (c) Sommerfeld (d) de Broglie
- 6.9 X-ray is  
 (a) phenomenon of conversion of kinetic energy into radiation.  
 (b) conversion of momentum  
 (c) conversion of energy into mass  
 (d) principle of conservation of charge
- 6.10 In an X-ray tube, the intensity of the emitted X-ray beam is increased by  
 (a) increasing the filament current  
 (b) decreasing the filament current  
 (c) increasing the target potential  
 (d) decreasing the target potential
- 6.11 The energy of a photon of characteristic X-ray from a Coolidge tube comes from  
 (a) the kinetic energy of the free electrons of the target  
 (b) the kinetic energy of ions of the target  
 (c) the kinetic energy of the striking electron  
 (d) an atomic transition in the target.
- 6.12 A Coolidge tube operates at 24800 V. The maximum frequency of X-radiation emitted from Coolidge tube is  
 (a)  $6 \times 10^{18}$  Hz (b)  $3 \times 10^{18}$  Hz  
 (c)  $6 \times 10^8$  Hz (d)  $3 \times 10^8$  Hz



- 6.13 In hydrogen atom, which of the following transitions produce a spectral line of maximum wavelength
- (a)  $2 \rightarrow 1$  (b)  $4 \rightarrow 1$   
(c)  $6 \rightarrow 5$  (d)  $5 \rightarrow 2$
- 6.14 In hydrogen atom, which of the following transitions produce a spectral line of maximum frequency
- (a)  $2 \rightarrow 1$  (b)  $6 \rightarrow 2$   
(c)  $4 \rightarrow 3$  (d)  $5 \rightarrow 2$
- 6.15 After pumping process in laser,
- (a) the number of atoms in the ground state is greater than the number of atoms in the excited state.  
(b) the number of atoms in the excited state is greater than the number of atoms in the ground state.  
(c) the number of atoms in the ground state is equal to the number atoms in the excited state.  
(d) No atoms are available in the excited state.
- 6.16 The chromium ions doped in the ruby rod
- (a) absorbs red light (b) absorbs green light  
(c) absorbs blue light (d) emits green light
- 6.17 What are cathode rays?
- 6.18 Write the properties of cathode rays.
- 6.19 Describe the J.J. Thomson method for determining the specific charge of electron.
- 6.20 Describe Millikan's oil drop experiment to determine the charge of an electron.
- 6.21 Explain the results of Rutherford  $\alpha$ -particle scattering experiment.
- 6.22 What are the drawbacks of Rutherford atom model?
- 6.23 State the postulates of Bohr atom model.
- 6.24 Obtain the expression for the radius of the  $n^{\text{th}}$  orbit of an electron based on Bohr's theory.
- 6.25 Prove that the energy of an electron for hydrogen atom in  $n^{\text{th}}$  orbit

$$\text{is, } E_n = \frac{-me^4}{8\epsilon_0^2 n^2 h^2} .$$

- 6.26 Explain the spectral series of hydrogen atom.
- 6.27 What is meant by energy level diagram?
- 6.28 What are the drawbacks of Sommerfeld atom model?
- 6.29 Define : excitation potential energy and ionization potential energy.
- 6.30 What are X-rays?
- 6.31 What are hard X-rays and soft x-rays?
- 6.32 Write the properties of X-rays?
- 6.33 Why ordinary plane transmission gratings cannot be used to produce diffraction effects in X-rays?
- 6.34 State and obtain Bragg's law.
- 6.35 Explain how a Bragg's spectrometer can be used to determine the wavelength of X-rays.
- 6.36 Explain the origin of characteristic x-rays.
- 6.37 State : Moseley's law.
- 6.38 Write the differences between spontaneous emission and stimulated emission.
- 6.39 What is meant by normal population?
- 6.40 What are the important characteristics of laser?
- 6.41 How does the laser light differ from ordinary light?
- 6.42 Explain the working of Ruby laser with neat sketch.
- 6.43 With the help of energy level diagram, explain the working of He-Ne laser.
- 6.44 What are various applications of laser in medical field?

### **Problems**

- 6.45 An electron beam passes through a transverse magnetic field of  $2 \times 10^{-3}$  tesla and an electric field  $E$  of  $3.4 \times 10^4$  V/m acting simultaneously. If the path of the electrons remain undeviated, calculate the speed of electrons. If the electric field is removed, what will be the radius of the electron path?
- 6.46 In Millikan's experiment, a drop of diameter  $10^{-4}$  cm with a density  $0.9 \text{ gm/cm}^3$  is observed. The plates are 2 cm apart. A potential of 72 V applied across the plates keeps the drops just in balance. How many electronic charges are there in the oil drop?

- 6.47 Calculate the distance of closest approach of  $\alpha$  -particles to the copper nucleus when  $\alpha$  -particles of 5 MeV are scattered back by a thin sheet of copper ( $Z$  for copper = 29).
- 6.48 For the Paschen series, calculate the wavelength of the first member and the series limit. Given  $R$ , Rydberg constant =  $1.094 \times 10^7 \text{m}^{-1}$ .
- 6.49 An X-ray diffraction of a crystal gave the closest line at an angle of  $6^\circ 27'$ . If the wavelength of X-ray is  $0.58 \text{\AA}$ , find the distance between the two cleavage planes.
- 6.50 How much should be the voltage of an X-ray tube so that the electrons emitted from the cathode may give an X-ray of wavelength  $1 \text{\AA}$  after striking the target.
- 6.51 Calculate the mass of an electron from the known values of specific charge and charge of electron.
- 6.52 Find the minimum wavelength of X-rays produced by an X-ray tube at 1000 kV.

#### Answers

- |  |                 |  |                 |
|--|-----------------|--|-----------------|
| <b>6.1</b> (a)   | <b>6.2</b> (c)  | <b>6.3</b> (c)                                     | <b>6.4</b> (c)  |
| <b>6.5</b> (b)   | <b>6.6</b> (b)  | <b>6.7</b> (b)                                     | <b>6.8</b> (c)  |
| <b>6.9</b> (a)   | <b>6.10</b> (a) | <b>6.11</b> (d)                                    | <b>6.12</b> (a) |
| <b>6.13</b> (c)  | <b>6.14</b> (a) | <b>6.15</b> (b)                                    | <b>6.16</b> (b) |
| <b>6.45</b> $v = 1.7 \times 10^7 \text{ms}^{-1}$ ; $r = 4.834 \times 10^{-2} \text{m}$ |                 |  |                 |
| <b>6.46</b> $n = 8$  |                 | <b>6.47</b> $r_o = 1.670 \times 10^{-14} \text{m}$ |                 |
| <b>6.48</b> $\lambda_1 = 18752 \text{\AA}$ ; $\lambda_\alpha = 8204 \text{\AA}$        |                 | <b>6.49</b> $d = 2.581 \text{\AA}$                 |                 |
| <b>6.50</b> $V = 12.4 \text{kV}$   |                 | <b>6.51</b> $m = 9.11 \times 10^{-31} \text{kg}$   |                 |
| <b>6.52</b> $\lambda_{\min} = 0.0124 \text{\AA}$                                       |                 |  |                 |

## 7. Dual Nature of Radiation and Matter and Relativity

The true nature of light is difficult to assess. Experiments showed that light exhibited wavelike properties of diffraction and interference. On the other hand, photoelectric effect indicates that light has the aspects of a particle photon, with both energy and momentum. Thus light exhibits a wave-particle duality.

The wave-particle duality was extended to particles as matter waves by Louis de Broglie. His theoretical study on the nature of particles and waves led to the invention of a new mechanics of particles called quantum mechanics.

### 7.1 Photoelectric effect

Photoelectric emission is the phenomena by which a good number of substances, chiefly metals, emit electrons under the influence of radiation such as  $\gamma$  rays, X-rays, ultraviolet and even visible light. This effect was discovered by Heinrich Hertz in 1887 while working with resonance electrical circuits. A year later, Hallwachs, Elster and Geitel investigated the phenomenon with a simple experimental arrangement.

#### 7.1.1 Hallwachs Experiment

Hallwachs experimental set-up to study the photo electric effect is shown in Fig 7.1. It consists of an evacuated quartz bulb with two zinc plates cathode C and anode A. The plates are connected to a battery and a sensitive galvanometer. In the absence of any radiation incident on the plates, there is no flow of current and hence there is no deflection in the galvanometer. But, when an electro magnetic radiation like ultraviolet radiation is allowed to fall on the plate C which is connected to the negative terminal of the battery, a current begins to flow, indicated by the deflection in the galvanometer (G). But, when ultraviolet radiation is

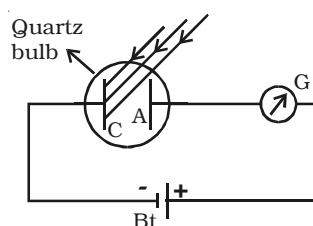

Fig 7.1 Photo-electric effect

made to fall on A, there is no deflection in the galvanometer. These observations reveal that the particles emitted by the plate C due to the photoelectric effect are negatively charged. These particles were found to be electrons. The observed current known as the photoelectric current is due to the flow of electrons.

After the study of photoelectric effect by Hallwachs, scientists J.J.Thomson, Lenard, Richardson, Compton did a series of experiments to study the relationship between photoelectric current, intensity of incident radiation, velocity and the kinetic energy of the photo electrons, and their dependence on the wave length of incident radiation used.

### **7.1.2 Effect of intensity of incident radiation on photo electric current**

Keeping the frequency of the incident radiation and the potential difference between the cathode and the anode at constant values, the intensity of incident radiation is varied. The corresponding photoelectric current is measured in the microammeter.

It is found that the photo electric current increases linearly with the intensity of incident radiation (Fig 7.2).

Since the photoelectric current is directly proportional to the number of photoelectrons emitted per second, it implies that the number of photoelectrons emitted per second is proportional to the intensity of incident radiation.

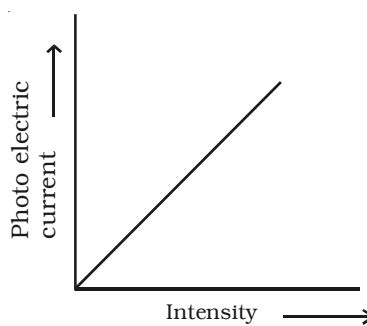

*Fig 7.2 Variation of photoelectric current with intensity of incident radiation.*

### **7.1.3 Effect of potential difference on the photoelectric current**

For a given metallic surface C, keeping the intensity ( $I_1$ ) and frequency of the incident radiation constant, the effect of potential difference between the plates on the photoelectric current can be studied. Fig 7.3 shows the variation of photo electric current with the potential difference  $V$  between the two plates. When the positive potential of A is increased, the photoelectric current is also increased. However, if the positive potential is further increased such that it is large enough to collect all the photo electrons emitted from the plate C, the photoelectric current reaches a certain maximum value and this

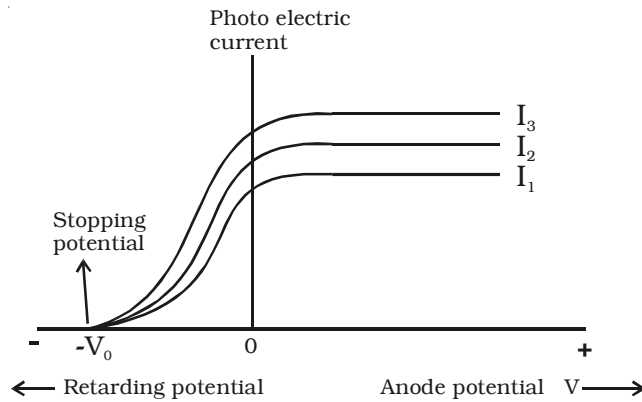

Fig 7.3 Variation of photo electric current with potential difference.

current is known as saturation current. If the potential of the plate A is made negative, the photocurrent does not immediately drop to zero but flows in the same direction as for positive potential. This shows that the photo electrons are emitted from the plate C with finite velocity. If the negative or retarding potential is further increased, the photo current decreases and finally becomes zero at a particular value. Thus, the minimum negative (retarding) potential given to the anode for which the photo electric current becomes zero is called the cut-off or stopping potential.

If  $m$  is the mass of the photo electron emitted with a velocity  $v_{max}$  then the kinetic energy associated with it is  $\frac{1}{2}mv_{max}^2$ .

Since at the stopping potential  $V_0$ , the fastest electron is just prevented from reaching the plate A, workdone in bringing the fastest electron to rest = kinetic energy of the fastest electron.

$$eV_0 = \frac{1}{2}mv_{max}^2$$

The above equation indicates that the stopping potential depends upon the velocity of the fastest electron.

The experiment is repeated with the incident radiation of same frequency, but of higher intensities  $I_2$  and  $I_3$ . It is found from the graph, the saturation currents are proportional to the intensities of the radiation. But, the stopping potential remains the same for all the intensities. Thus, for a given frequency of incident radiation, the stopping potential is independent of its intensity.

### 7.1.4 Effect of frequency of incident radiation on stopping potential

Keeping the photosensitive plate (C) and intensity of incident radiation a constant, the effect of frequency of the incident radiations

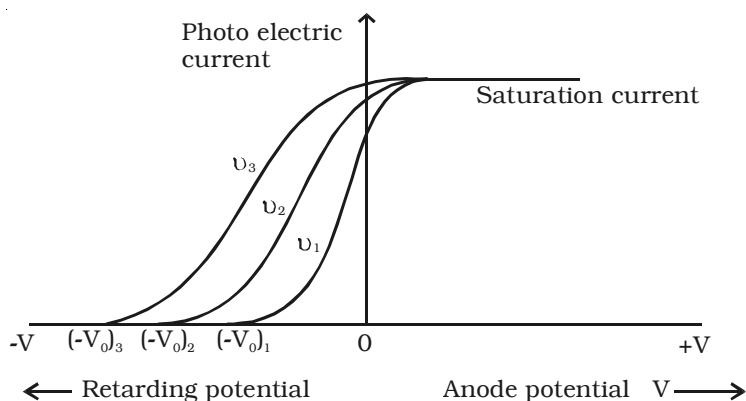

Fig 7.4 Variation of photoelectric current with applied potential difference for different frequency of incident radiation.

on stopping potential is studied. Fig 7.4 shows the variation of the photo electric current with the applied potential difference  $V$  for three different frequencies. From the graph, it is found that higher the frequency of the incident radiation, higher is the value of stopping potential  $V_o$ . For frequencies  $\nu_3 > \nu_2 > \nu_1$ , the corresponding stopping potentials are in the same order  $(V_o)_3 > (V_o)_2 > (V_o)_1$ .

It is concluded from the graph that, the maximum kinetic energy of the photoelectrons varies linearly with the frequency of incident radiation but is independent of its intensity.

If the frequency of the incident radiation is plotted against the corresponding stopping potential, a straight line is obtained as shown in Fig 7.5. From this graph, it is found that at a frequency  $\nu_o$ , the value of the

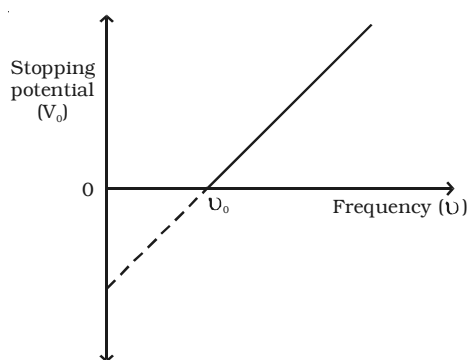

Fig 7.5 Variation of stopping potential with frequency of incident radiation.

stopping potential is zero. This frequency is known as the threshold frequency for the photo metal used. The photoelectric effect occurs above this frequency and ceases below it. Therefore, threshold frequency is defined as the minimum frequency of incident radiation below which the photoelectric emission is not possible completely, however high the intensity of incident radiation may be. The threshold frequency is different for different metals.

#### **7.1.5 Laws of photoelectric emission**

The experimental observations on photoelectric effect may be summarized as follows, which are known as the fundamental laws of photoelectric emission.

(i) For a given photo sensitive material, there is a minimum frequency called the threshold frequency, below which emission of photoelectrons stops completely, however great the intensity may be.

(ii) For a given photosensitive material, the photo electric current is directly proportional to the intensity of the incident radiation, provided the frequency is greater than the threshold frequency.

(iii) The photoelectric emission is an instantaneous process. i.e. there is no time lag between the incidence of radiation and the emission of photo electrons.

(iv) The maximum kinetic energy of the photo electrons is directly proportional to the frequency of incident radiation, but is independent of its intensity.

#### **7.1.6 Light waves and photons**

The electromagnetic theory of light proposed by Maxwell could not explain photoelectric effect. But, Max Planck's quantum theory successfully explains photoelectric effect. According to Planck's quantum theory, light is emitted in the form of discrete packets of energy called 'quanta' or photon. The energy of each photon is  $E = h\nu$ , where  $h$  is Planck's constant.

Photon is neither a particle nor a wave. In the phenomena like interference, diffraction, polarisation, the photon behaves like a wave. In the phenomena like emission, absorption and interaction with matter (photo electric effect) photon behaves as a particle. Hence light photon has a dual nature.



### 7.1.7 Einstein's photoelectric equation

In 1905, Albert Einstein, successfully applied quantum theory of radiation to photoelectric effect.

According to Einstein, the emission of photo electron is the result of the interaction between a single photon of the incident radiation and an electron in the metal. When a photon of energy  $h\nu$  is incident on a metal surface, its energy is used up in two ways :

(i) A part of the energy of the photon is used in extracting the electron from the surface of metal, since the electrons in the metal are bound to the nucleus. This energy  $W$  spent in releasing the photo electron is known as photoelectric work function of the metal. The work function of a photo metal is defined as the minimum amount of energy required to liberate an electron from the metal surface.

(ii) The remaining energy of the photon is used to impart kinetic energy to the liberated electron.

If  $m$  is the mass of an electron and  $v$ , its velocity then

Energy of the incident photon =  
Work function + Kinetic energy of the electron

$$h\nu = W + \frac{1}{2} mv^2 \quad \dots(1)$$

If the electron does not lose energy by internal collisions, as it escapes from the metal, the entire energy  $(h\nu - W)$  will be exhibited as the kinetic energy of the electron. Thus,  $(h\nu - W)$  represents the maximum kinetic energy of the ejected photo electron. If  $v_{max}$  is the maximum velocity with which the photoelectron can be ejected, then

$$h\nu = W + \frac{1}{2} mv_{max}^2 \quad \dots(2)$$

This equation is known as Einstein's photoelectric equation.

When the frequency ( $\nu$ ) of the incident radiation is equal to the threshold frequency ( $\nu_o$ ) of the metal surface, kinetic energy of the electron is zero. Then equation (2) becomes,

$$h\nu_o = W \quad \dots(3)$$

Substituting the value of  $W$  in equation (2) we get,

$$h\nu - h\nu_o = \frac{1}{2} mv_{max}^2 \quad \text{(or)} \quad h(\nu - \nu_o) = \frac{1}{2} mv_{max}^2$$

This is another form of Einstein's photoelectric equation.

### 7.1.8 Experimental verification of Einstein's photoelectric equation

Einstein's photoelectric equation is,

$$\frac{1}{2} mv^2 = h(\nu - \nu_0) \quad \dots(1)$$

If  $V_0$  is the stopping potential and  $e$ , the electronic charge, then

$$\frac{1}{2} mv^2 = eV_0 \quad \dots(2)$$

From equations (1) and (2),

$$eV_0 = h(\nu - \nu_0)$$

$$\text{(or)} \quad V_0 = \left(\frac{h}{e}\right)\nu - \left(\frac{h}{e}\right)\nu_0 \quad \dots(3)$$

This is an equation of a straight line. Millikan verified equation (3) experimentally and found that it is in harmony with the observed facts.

### 7.2 Photoelectric cells and their applications

The photoelectric cell is a device which converts light energy into electrical energy. The photo electric cells are of three types:

- (i) Photo emissive cell
- (ii) Photo voltaic cell and
- (iii) Photo conductive cell

In this section, a simple photo emissive cell is discussed. It consists of a highly evacuated bulb B made of glass or quartz. A semi cylindrical metal plate C connected to the negative terminal of a battery, acts as cathode. This plate is coated with a low work function material such as caesium oxide, in order to get large number of photo electrons. A thin platinum wire A is connected to the positive terminal of the battery and kept along the axis of the metal plate C and this serves as the anode as shown in Fig 7.6.

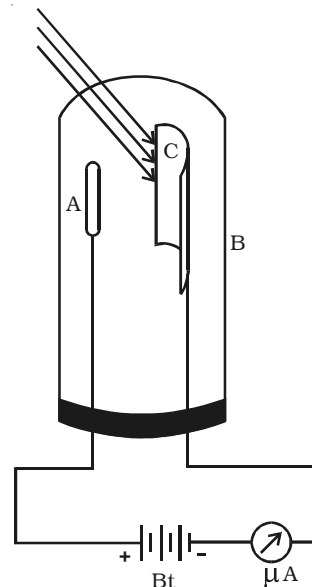

Fig 7.6 Photo emissive cell

When a light of suitable wave length falls on the cathode, photo electrons are emitted, which are attracted by the anode A. The resulting current is measured by a micro ammeter. The current produced by this type of cell is proportional to the intensity of the incident light for a given frequency.

### ***Applications of photo electric cells***

(i) Photoelectric cells are used for reproducing sound in cinematography.

(ii) They are used for controlling the temperature of furnaces.

(iii) Photoelectric cells are used for automatic switching on and off the street lights.

(iv) Photoelectric cells are used in the study of temperature and spectra of stars.

(v) Photoelectric cells are also used in obtaining electrical energy from sunlight during space travel.

(vi) These cells are used in instruments measuring light illumination.

(vii) These cells are used in opening and closing of door automatically.

(viii) Photoelectric cells are used in burglar alarm and fire alarm. In burglar alarm, ultraviolet light is continuously made to fall on the photo-cell installed at the door-way. A person entering the door interrupts the beam falling on the photo-cell. The abrupt change in photocurrent is used to start an electric bell ringing. In fire alarm, a number of photo-cells are installed at suitable places in a building. In the event of breaking out of fire, light radiations fall upon the photo-cell. This completes the electric circuit through an electric bell or a siren which starts operating as a warning signal.

### **7.3 Matter waves**

The radiant energy has dual aspects of particle and wave, hence a natural question arises, if radiation has a dual nature, why not the matter. In 1924, a French Physicist Louis de Broglie put forward the bold hypothesis that moving particles should possess wave like

properties under suitable conditions. He reasoned this idea, from the fact, that nature is symmetrical and hence the basic physical entities – matter and energy should have symmetrical characters. If radiation shows dual aspects, so should matter.

### **7.3.1 de Broglie's wavelength of matter waves**

de Broglie equated the energy equations of Planck (wave) and Einstein (particle).

For a wave of frequency  $\nu$ , the energy associated with each photon is given by Planck's relation,

$$E = h\nu \quad \dots(1)$$

where  $h$  is Planck's constant.

According to Einstein's mass energy relation, a mass  $m$  is equivalent to energy,

$$E = mc^2 \quad \dots(2)$$

where  $c$  is the velocity of light.

If,  $h\nu = mc^2$

$$\therefore \frac{hc}{\lambda} = mc^2 \text{ (or) } \lambda = \frac{h}{mc} \quad \dots(3) \quad \text{(since } \nu = \frac{c}{\lambda} \text{)}$$

For a particle moving with a velocity  $v$ , if  $c = v$  from equation (3)

$$\lambda = \frac{h}{mv} = \frac{h}{p} \quad \dots(4)$$

where  $p = mv$ , the momentum of the particle. These hypothetical matter waves will have appreciable wavelength only for very light particles.

### **7.3.2 de Broglie wavelength of an electron**

When an electron of mass  $m$  and charge  $e$  is accelerated through a potential difference  $V$ , then the energy  $eV$  is equal to kinetic energy of the electron.

$$\frac{1}{2} mv^2 = eV \quad \text{(or) } v = \sqrt{\frac{2eV}{m}} \quad \dots(1)$$

The de Broglie wavelength is ,

$$\lambda = \frac{h}{mv}$$

Substituting the value of  $v$ ,

$$\lambda = \frac{h}{m\sqrt{\frac{2eV}{m}}} = \frac{h}{\sqrt{2meV}} \quad \dots(2)$$

Substituting the known values in equation (2),

$$\lambda = \frac{12.27}{\sqrt{V}} \text{ \AA}$$

If  $V = 100$  volts, then  $\lambda = 1.227 \text{ \AA}$  i.e., the wavelength associated with an electron accelerated by 100 volts is  $1.227 \text{ \AA}$ .

Since  $E = eV$  is kinetic energy associated with the electron, the equation (2) becomes,

$$\lambda = \frac{h}{\sqrt{2mE}}$$

### 7.3.3 Wave mechanical concept of atom

According to de Broglie's hypothesis, an electron of mass  $m$  in motion with a velocity  $v$  is associated with a wave whose wavelength  $\lambda$  is given by

$$\lambda = \frac{h}{mv} \quad \dots(1)$$

where  $h$  is Planck's constant.

On the basis of de Broglie's hypothesis, an atom model was proposed in which the stationary orbits of Bohr's model were retained, but with the difference that electron in various orbits behaves as a wave. This is shown in Fig 7.7.

It was suggested that stationary orbits are those in which orbital circumference ( $2\pi r$ ) is an integral multiple of de Broglie wavelength  $\lambda$ ,

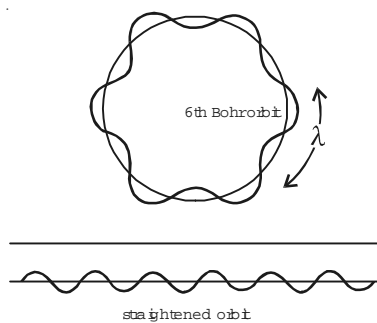

Fig 7.7 Wave concept of atom

i.e., stationary orbits for an electron are those which contain the complete waves of electron.

$$\text{Thus, } 2\pi r = n\lambda \quad \dots(2)$$

where  $n = 1, 2, 3 \dots$  and  $r$  is the radius of the circular orbit.

Substituting equation (1) in equation (2),

$$2\pi r = n\lambda \left( \frac{h}{mv} \right) \quad (\text{or}) \quad mv r = \frac{nh}{2\pi} \quad \dots(3)$$

From equation (3), it is seen that the total angular momentum of the moving electron is an integral multiple of  $\frac{h}{2\pi}$ . Thus, de Broglie's concept confirms the Bohr's postulate.

#### **7.4 Electron microscope**

The electron microscope, like optical microscope, is an instrument principally used in the research laboratory for magnifying small objects. The wave nature of moving electron is the basis for the electron microscope. The resolving power of a microscope is the least distance between two points which can be distinguished. The resolving power of a microscope is limited by the wave length of the radiation used. In optical microscope, the visible light is used to illuminate the object and the highest magnification obtained with the best optical microscope is about 2000. Since, the wavelength of X-rays is smaller than that of the visible light, one can think of having an X-ray microscope. However, X-rays cannot be focussed as visible radiations are focussed using lenses. On the other hand, electrons having de Broglie wavelength of the order of X-rays can be focussed easily using electric and magnetic fields and one can build a high resolving power microscope using electrons.

For electrons accelerated by a potential difference of about 60,000 volts, the wavelength is about  $5 \times 10^{-12}$  m. This is  $10^5$  times smaller than that of visible light. Hence the resolving power of an electron microscope will be 1,00,000 times greater than that of an optical microscope.

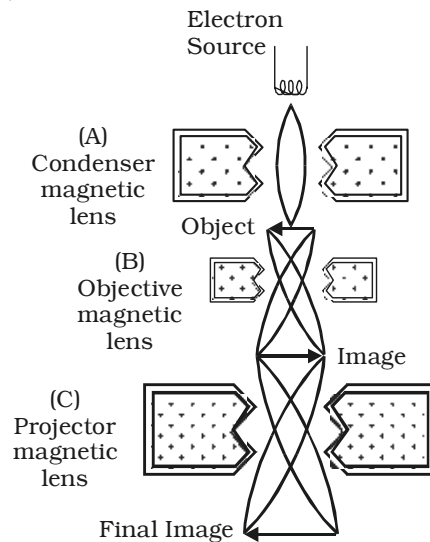

*Fig 7.8 Schematic diagram of electron microscope*

**Construction and working**

The schematic diagram of an electron microscope is shown in Fig 7.8. An electron microscope is similar in principle to an optical microscope. The modern electron microscope is usually of transmission type in which magnetic lenses of short focal length are used to obtain large magnification. An electron beam emitted by a filament is accelerated through a large potential difference in a device called electron gun. The fine beam of electrons is made to pass through the centre of the doughnut shaped electromagnet A (condenser magnetic lens). The electrons get deflected to form a parallel beam which strikes the object to be magnified. It should be noted that the electrons will be transmitted more through the transparent parts of the object and transmitted in less number through comparatively denser portions. The transmitted beam will thus have the likeness of the object traversed by it. The second electro magnet B (objective magnetic lens) causes the electron beam to diverge to produce enlarged image of the object. The electromagnet C (projector magnetic lens) focusses the electron beam from the part of the enlarged image on the fluorescent screen producing still greater

magnification. The image obtained on the fluorescent screen is made visible by scintillation for direct view. It can also be obtained on a suitable photographic plate for a permanent record. Sharp focussing is obtained by adjusting the intensity of magnetic fields produced by electro magnets. Since, the electron beam operates in vacuum, the apparatus is mounted in a chamber which is completely evacuated.

**Uses:**

(i) It is used in the industry, to study the structure of textile fibres, surface of metals, composition of paints etc.

(ii) In medicine and biology, it is used to study virus, and bacteria.

(iii) In Physics, it has been used in the investigation of atomic structure and structure of crystals in detail.

**Limitations**

An electron microscope is operated only in high vacuum. This prohibits the use of the microscope to study living organisms which would evaporate and disintegrate under such conditions.

**7.5 Relativity**

In Newtonian mechanics, mass, time, length and space were treated as absolute. It is regarded that space existed without any reference to objects. Space was considered absolute and at rest.

In the wave theory of light, it is assumed that a medium called ether exists in space and pervaded all space in the universe. But as per Michelson and Morley experiment, the concept of ether and absolute space become meaningless. In Einstein's view, there is no absolute space and all motions are relative. The time, mass, length and space are interdependent and are not absolute. Einstein, in 1905, profounded the special theory of relativity. The special theory of relativity deals with objects and systems, which are either moving at a constant speed with respect to one another or at rest.

---

*Albert Einstein published his special theory of relativity and the theory of photo electric effect in the same year 1905. It was a very productive year for him - and for Physics.*



### **7.5.1 Concept of Space**

In classical mechanics, motion in absolute space led to two useful results.

(i) Fixed frame of reference by which the position or motion of any object in the universe could be measured.

(ii) The geometrical form of an object remains the same irrespective of changes in position or state of motion of the object or observer.

### **Concept of time**

According to classical mechanics,

(i) The time interval between two events has the same value for all observers irrespective of their motion.

(ii) If two events are simultaneous for an observer, they are simultaneous for all observers, irrespective of their position or motion. This means simultaneity is absolute.

### **Concept of mass**

In classical mechanics, the mass of the body is absolute and constant and independent of the motion of the body.

### **7.5.2 Frame of reference**

A system of co-ordinate axes which defines the position of a particle in two or three dimensional space is called a frame of reference.

The simplest frame of reference is the Cartesian co-ordinate system in which the position of a particle is specified by three co-ordinates  $x, y$  and  $z$ . There are infinite number of reference frames in the universe. Our earth itself is a frame of reference. There are two types of frames of reference (i) inertial and (ii) non – inertial frames.

#### **(i) Inertial (or) unaccelerated frames.**

A frame of reference is said to be inertial, when the bodies in this frame obey Newton's law of inertia and other laws of Newtonian mechanics. In this frame, a body remains at rest or in continuous motion unless acted upon by an external force.

#### **(ii) Non-inertial (or) accelerated frames**

A frame of reference is said to be a non-inertial frame, when a body not acted upon by an external force, is accelerated. In this frame, Newton's laws are not valid.

## 7.6 Special theory of relativity

It is a direct outcome of new realisations of the nature of mass, length and time. It discards the absolute motion through space and deals with objects or observers, that are moving with uniform velocities relative to each other.

The two fundamental postulates of the special theory of relativity are :

- (i) The laws of Physics are the same in all inertial frames of reference.
- (ii) The velocity of light in free space is a constant in all the frames of reference.

### 7.6.1 Length contraction

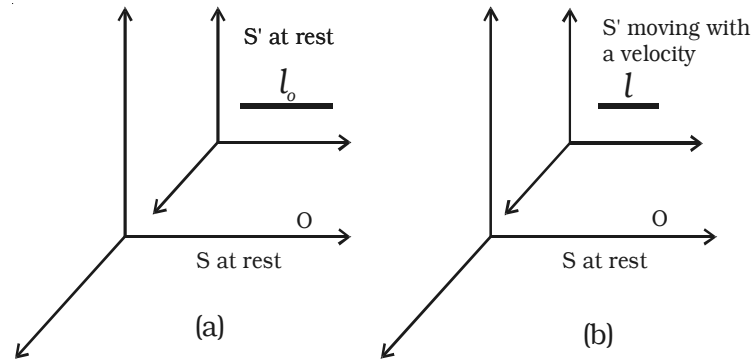

Fig 7.9 Length contraction

Consider two frames of references S and S' to be initially at rest. A rod is placed in the frame of reference S' and an observer O is in S (Fig 7.9). The length of the rod in S' as measured by the observer in S is  $l_0$ .

Now the frame of reference S' moves with a velocity  $v$  along the positive X-axis. Now, the length of the rod is measured as  $l$  by the observer in S. Then

$$l = l_0 \sqrt{1 - \frac{v^2}{c^2}}$$

i.e.,  $l < l_0$

Thus the length of the rod moving with a velocity  $v$  relative to the observer at rest is contracted by a factor  $\sqrt{1 - \frac{v^2}{c^2}}$  in the direction of motion. This is known as Lorentz – Fitzgerald contraction.

Example : A circular object will appear as an ellipse for a fast moving observer as shown in Fig 7.10.

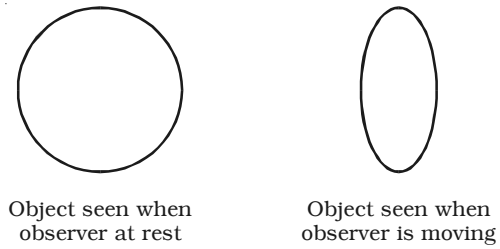

Fig. 7.10

### 7.6.2 Time dilation

Consider two frames S and S'. Let S' be moving with a velocity  $v$  with respect to S in the positive X-direction. Suppose a clock situated in the frame S' at a position gives out signals at an interval  $t_0$ .

If this interval is observed by an observer in frame S, then the interval  $t$  recorded by him is

$$t = \frac{t_0}{\sqrt{1 - \frac{v^2}{c^2}}}$$

i.e.  $t > t_0$

To a stationary observer in S, time interval appears to be lengthened by a factor  $\frac{1}{\sqrt{1 - \frac{v^2}{c^2}}}$  In otherwords, a moving clock appears

to be slowed down to a stationary observer. This is known as time dilation.

Example : The clock in the moving space ships will appear to go slower than the clocks on the earth.

### 7.6.3 Variation of mass with velocity

According to Newtonian mechanics, the mass of a body does not change with velocity. But according to Einstein, the mass of the body changes with velocity. Einstein established the relation between the mass of a body at rest ( $m_0$ ) and the mass of the same body moving with a velocity  $v$  is,

$$m = \frac{m_0}{\sqrt{1 - \frac{v^2}{c^2}}}$$

Example : Electrons accelerated in a particle accelerator, cyclotron with a very high velocity acquire increased mass, exactly as predicted by the above expression.

### 7.7 Einstein's mass-energy equivalence

Consider a body of rest mass  $m_0$ . A force  $F$  is acting on it in X-direction. According to Newton's second law of motion, force is defined as the rate of change of momentum.

$$\text{i.e. } F = \frac{d}{dt} (mv) \quad \dots(1)$$

According to the theory of relativity, both mass and velocity are variable, therefore

$$F = m \frac{dv}{dt} + v \frac{dm}{dt} \quad \dots(2)$$

If a body is displaced through a distance  $dx$  due to the force  $F$  then, the increase in kinetic energy  $dE_k$  of the body is

$$\begin{aligned} dE_k &= Fdx \\ &= \left( m \frac{dv}{dt} + v \frac{dm}{dt} \right) dx \\ &= m dv \frac{dx}{dt} + v dm \frac{dx}{dt} \\ dE_k &= mv dv + v^2 dm \quad \dots(3) \end{aligned}$$

From Einstein's theory of relativity

$$m = \frac{m_0}{\sqrt{1 - v^2/c^2}}$$

$$m^2 = \frac{m_0^2 c^2}{c^2 - v^2}$$

$$m^2 c^2 - m^2 v^2 = m_0^2 c^2$$

Differentiating we get,

$$c^2 2m dm - v^2 2m dm - m^2 2v dv = 0.$$

$$c^2 dm = mv dv + v^2 dm \quad \dots(4)$$

Comparing equations (3) and (4) we get,

$$dE_k = c^2 dm \quad \dots(5)$$

Thus the change in kinetic energy  $dE_k$  is directly proportional to the change in mass  $dm$

When a body is at rest, its velocity is zero and  $m = m_0$ . When its velocity is  $v$  its mass becomes  $m$ . Therefore integrating equation (5)

$$\int_0^{E_k} dE_k = c^2 \int_{m_0}^m dm$$

$$E_k = c^2 (m - m_0) = mc^2 - m_0 c^2$$

This is the relativistic formula for kinetic energy.  $m_0$  is the rest mass and  $m_0 c^2$  is the internal energy (rest mass energy or rest energy).

$\therefore$  Total energy = kinetic energy of the moving body  
+ rest mass energy

$$\begin{aligned} E &= E_k + m_0 c^2 \\ &= mc^2 - m_0 c^2 + m_0 c^2 \\ E &= mc^2 \end{aligned}$$

This is Einstein's mass-energy equivalence.

### **Implications of the equivalence between mass and energy**

Particles like electron, proton, neutron have mass. If a particle has mass, it has rest energy  $m_0 c^2$  and may or may not have other forms of energy such as kinetic energy and potential energy. The particle of light, the photon has zero mass but has energy.

It is possible to convert an isolated system of particles with mass into a system of particles with less mass, even zero mass. Similarly, it is possible to convert a particle of zero mass into a particle with mass.

(i.e) Rest energy is converted into other types of energy (mass is converted into energy) or other types of energy are converted into rest energy (energy is converted into mass). Hence, the statement “mass energy equivalence” comes true and the total energy is conserved in the isolated system.

**Example :** When an electron meets its antiparticle the positron, both of them annihilate and form two photons. Since, the total energy is conserved, the total energy associated with the electron - positron pair (kinetic energy + rest energy) is transferred to the photons that have no rest energy (no mass). Also, an energetic photon (zero mass) can create an electron - positron pair (particles with mass).

Other examples such as nuclear fission and fusion process are discussed in the next chapter nuclear physics.

### Solved Problems

7.1 The work function of zinc is  $6.8 \times 10^{-19}$  J. What is the threshold frequency for emission of photoelectrons from zinc?

**Data :**  $W = 6.8 \times 10^{-19}$  J  $\nu_0 = ?$

**Solution :** Work function  $W = h\nu_0$

$$\therefore h\nu_0 = 6.8 \times 10^{-19}$$

$$\nu_0 = \frac{6.8 \times 10^{-19}}{6.626 \times 10^{-34}}$$

$$\nu_0 = 1.026 \times 10^{15} \text{ Hz.}$$

7.2 A metallic surface when illuminated with light of wavelength  $3333 \text{ \AA}$  emits electrons with energies upto  $0.6 \text{ eV}$ . Calculate the work function of the metal.

**Data :**  $\lambda = 3333 \text{ \AA}$ ,  $K.E = 0.6 \text{ eV}$ ;  $W = ?$

**Solution :** Work function,  $W = h\nu - \text{kinetic energy}$

$$\text{or } W = \frac{hc}{\lambda} - K.E$$

$$= \left( \frac{6.626 \times 10^{-34} \times 3 \times 10^8}{3333 \times 10^{-10}} \right) - (0.6 \times 1.6 \times 10^{-19})$$

$$= (5.96 \times 10^{-19}) - (0.96 \times 10^{-19})$$

$$W = 5 \times 10^{-19} \text{ J}$$

$$W = \frac{5 \times 10^{-19}}{1.6 \times 10^{-19}} \text{ eV}$$

$$W = 3.125 \text{ eV.}$$

- 7.3 Lithium has a work function of 2.3 eV. It is exposed to light of wavelength  $4.8 \times 10^{-7}$  m. Find the maximum kinetic energy with which the electron leaves the surface. What is the longest wavelength which can produce the photo electrons?

(Given  $h = 6.626 \times 10^{-34}$  Js ;  $e = 1.6 \times 10^{-19}$  C).

**Data :**  $W = 2.3$  eV ;  $h = 6.626 \times 10^{-34}$  Js ;  $e = 1.6 \times 10^{-19}$  C.

longest wavelength = ? ; kinetic energy = ?

**Solution :** Kinetic energy of ejected electrons =  $h\nu - W$

$$\text{But, } h\nu = \frac{hc}{\lambda} = \frac{6.626 \times 10^{-34} \times 3 \times 10^8}{4.8 \times 10^{-7}} \text{ joule}$$

$$h\nu = \frac{6.626 \times 10^{-34} \times 3 \times 10^8}{4.8 \times 10^{-7} \times 1.6 \times 10^{-19}}$$

$$h\nu = 2.588 \text{ eV}$$

$\therefore$  Kinetic energy of ejected electrons

$$= 2.588 - 2.3$$

$$\text{K.E} = 0.288 \text{ eV}$$

$$\text{Work function } W = h\nu_0 = \frac{hc}{\lambda_0}$$

$$\therefore \lambda_0 = \frac{hc}{W}$$

$$\text{longest wavelength } \lambda_0 = \frac{6.626 \times 10^{-34} \times 3 \times 10^8}{2.3 \times 1.6 \times 10^{-19}}$$

$$\lambda_0 = 5.40 \times 10^{-7} \text{ m.}$$

- 7.4 Calculate the de Broglie wave length of an electron, if the speed is  $10^5 \text{ ms}^{-1}$ . (Given  $m = 9.1 \times 10^{-31}$  kg;  $h = 6.626 \times 10^{-34}$  Js)

**Data :**  $m = 9.1 \times 10^{-31}$  kg ;  $v = 10^5 \text{ ms}^{-1}$  ;

$h = 6.626 \times 10^{-34}$  Js ;  $\lambda = ?$

**Solution :** Wave length  $\lambda = \frac{h}{mv}$

$$= \frac{6.626 \times 10^{-34}}{9.1 \times 10^{-31} \times 10^5}$$

$$\lambda = 72.81 \text{ \AA}$$

7.5 What is the de Broglie wave length of an electron of kinetic energy 120 eV?

**Data :**  $K.E = 120 \text{ eV} = 120 \times 1.6 \times 10^{-19} \text{ J} ; \lambda = ?$

**Solution :**  $\lambda = \frac{h}{\sqrt{2mE}}$

$$\lambda = \frac{6.626 \times 10^{-34}}{\sqrt{2 \times 9.1 \times 10^{-31} \times 120 \times 1.6 \times 10^{-19}}}$$

$$\lambda = 1.121 \times 10^{-10} \text{ m.}$$

7.6 In the Bohr model of hydrogen atom, what is the de Broglie wave length  $\lambda$  for the electron when it is in the (i)  $n = 1$  level and (ii)  $n = 4$  level. In each case, compare the de Broglie wave length to the circumference of the orbit.

**Data :**  $n = 1, n = 4, \lambda = ?$

**Solution :** By Bohr's first postulate,

$$\text{angular momentum of the electron} = \frac{nh}{2\pi}$$

$$mvr = \frac{nh}{2\pi}$$

$$\therefore \frac{2\pi r}{n} = \frac{h}{mv} \quad \dots(1)$$

$$\text{But, } \lambda = \frac{h}{mv} \quad \dots(2) \quad (\text{de Broglie wave length})$$

From equations (1) and (2)

$$\lambda = \frac{2\pi r}{n} \quad \dots(3)$$



(i)  $n = 1, r = r_1 = 0.53 \text{ \AA}$   
 $\therefore \lambda_1 = 2\pi r_1 = 2\pi (0.53) \text{ \AA} = 3.328 \text{ \AA}.$

From equation (3)  $\frac{\lambda}{2\pi r} = \frac{1}{n}$ , for  $n = 1$ ,

$$\frac{\lambda}{2\pi r} = 1, \text{ i.e. } \lambda = 2\pi r$$

$\therefore$  In first orbit, de Broglie wavelength of the electron is equal to the circumference of the orbit.

(ii)  $n = 4, r_4 = 4^2 r_1.$

From equation (3)  $\lambda_4 = \frac{2\pi r_4}{4} = \frac{2\pi(4^2 r_1)}{4}$

i.e.  $\lambda_4 = 2\pi \times 4 \times (0.53) \text{ \AA}$   
 $\lambda_4 = 13.313 \text{ \AA}$

and from  $\lambda_4 = \frac{2\pi r_4}{4}$ , the de Broglie wavelength of the electron in the fourth orbit is equal to one fourth of the perimeter.

7.7 Find the accelerating potential of the electron, when its de Broglie wavelength is  $1 \text{ \AA}$ .

**Data :**  $\lambda = 1 \text{ \AA} ; V = ?$

**Solution :**  $\lambda = \frac{12.27}{\sqrt{V}} \text{ \AA}.$

$$\sqrt{V} = \frac{12.27 \times 10^{-10}}{\lambda} = \frac{12.27 \times 10^{-10}}{1 \times 10^{-10}}$$

$$V = (12.27)^2 = 150.55 \text{ V}$$

7.8 At what speed is a particle moving if the mass is equal to three times its rest mass.

**Data :**  $m = 3 m_0 ; v = ?$

**Solution :** 
$$m = \frac{m_0}{\sqrt{1 - \frac{v^2}{c^2}}}$$

$$3m_0 = \frac{m_0}{\sqrt{1 - \frac{v^2}{c^2}}}$$

$$\begin{aligned} v &= 0.943 c \\ &= 0.943 \times 3 \times 10^8 \\ v &= 2.829 \times 10^8 \text{ ms}^{-1} \end{aligned}$$

7.9 How fast would a rocket have to go relative to an observer for its length to be corrected to 99% of its length at rest.

**Data :**  $\frac{l}{l_0} = 99\% = \frac{99}{100}; \quad v = ?$

**Solution :** 
$$l = l_0 \sqrt{1 - \frac{v^2}{c^2}}$$

$$l = \frac{99}{100} l_0$$

$$\frac{l}{l_0} = \frac{99}{100}$$

$$\therefore \frac{99}{100} = \sqrt{1 - \frac{v^2}{c^2}}$$

$$\begin{aligned} \therefore v &= 0.141 c \\ v &= 0.141 \times 3 \times 10^8 \\ v &= 0.423 \times 10^8 \text{ ms}^{-1} \end{aligned}$$

### Self evaluation

*(The questions and problems given in this self evaluation are only samples. In the same way any question and problem could be framed from the text matter. Students must be prepared to answer any question and problem from the text matter, not only from the self evaluation.)*

- 7.1 A photon of frequency  $\nu$  is incident on a metal surface of threshold frequency  $\nu_0$ . The kinetic energy of the emitted photoelectron is
- (a)  $h(\nu - \nu_0)$                       (b)  $h\nu$   
(c)  $h\nu_0$                                 (d)  $h(\nu + \nu_0)$
- 7.2 The work function of a photoelectric material is 3.3 eV. The threshold frequency will be equal to
- (a)  $8 \times 10^{14}$  Hz                      (b)  $8 \times 10^{10}$  Hz  
(c)  $5 \times 10^{20}$  Hz                      (d)  $4 \times 10^{14}$  Hz.
- 7.3 The stopping potential of a metal surface is independent of
- (a) frequency of incident radiation  
(b) intensity of incident radiation  
(c) the nature of the metal surface  
(d) velocity of the electrons emitted.
- 7.4 At the threshold frequency, the velocity of the electrons is
- (a) zero                                      (b) maximum  
(c) minimum                                (d) infinite
- 7.5 The photoelectric effect can be explained on the basis of
- (a) corpuscular theory of light  
(b) wave theory of light  
(c) electromagnetic theory of light  
(d) quantum theory of light
- 7.6 The wavelength of the matter wave is independent of
- (a) mass                                      (b) velocity  
(c) momentum                              (d) charge

7.7 If the kinetic energy of the moving particle is  $E$ , then the de Broglie wavelength is,

(a)  $\lambda = \frac{h}{\sqrt{2mE}}$

(b)  $\lambda = \frac{\sqrt{2mE}}{h}$

(c)  $\lambda = h\sqrt{2mE}$

(d)  $\lambda = \frac{h}{E\sqrt{2m}}$

7.8 The momentum of the electron having wavelength  $2\text{\AA}$  is

(a)  $3.3 \times 10^{24} \text{ kg m s}^{-1}$

(b)  $6.6 \times 10^{24} \text{ kg m s}^{-1}$

(c)  $3.3 \times 10^{-24} \text{ kg m s}^{-1}$

(d)  $6.6 \times 10^{-24} \text{ kg m s}^{-1}$

7.9 According to relativity, the length of a rod in motion

(a) is same as its rest length

(b) is more than its rest length

(c) is less than its rest length

(d) may be more or less than or equal to rest length depending on the speed of the rod

7.10 If 1 kg of a substance is fully converted into energy, then the energy produced is

(a)  $9 \times 10^{16} \text{ J}$

(b)  $9 \times 10^{24} \text{ J}$

(c) 1 J

(d)  $3 \times 10^8 \text{ J}$

7.11 What is photoelectric effect?

7.12 Define stopping potential.

7.13 Define threshold frequency.

7.14 Define work function.

7.15 Explain the variation of photoelectric current with applied voltage.

7.16 State the laws of photoelectric emission.

7.17 Explain Einstein's theory of photoelectric effect

7.18 What are photo-cells?

7.19 What are the applications of photo-cells?

7.20 What are matter waves?

- 7.21 Derive an expression for de Broglie wavelength of matter waves.
- 7.22 Draw a neat sketch of an electron microscope. Explain its working.
- 7.23 Mention the applications of electron microscope.
- 7.24 Define frame of reference.
- 7.25 State the postulates of special theory of relativity.
- 7.26 Discuss the concept of space, time and mass.
- 7.27 Explain length contraction.
- 7.28 Explain time dilation.
- 7.29 If a body moves with the velocity of light, what will be its mass? Comment on your result.
- 7.30 Derive Einstein's mass energy equivalence.

### **Problems**

- 7.31 The photoelectric threshold wavelength of a metal is 5000 Å. Find (i) the work function in electron volts and (ii) the kinetic energy of the photoelectrons in electron volts, ejected by the light of wave length 4000 Å.
- 7.32 Red light of wavelength 670 nm produces photoelectrons from a certain metal which requires a stopping potential of 0.5 V. What is the work function and threshold wavelength of the metal?
- 7.33 Calculate the velocity of a photoelectron if the work function of the target material is 1.24 eV and the wave length of incident light is  $4.36 \times 10^{-7}$  m.
- 7.34 The rest mass of an electron is  $9.1 \times 10^{-31}$  kg. What will be its mass if it moves with  $4/5^{\text{th}}$  of the speed of light?
- 7.35 Calculate the threshold frequency of photons which can remove photoelectrons from (i) caesium and (ii) nickel surface (work function of caesium is 1.8 eV and work function of nickel is 5.9 eV)
- 7.36 If the speed of photoelectrons is  $10^4 \text{ ms}^{-1}$ , calculate the frequency of the radiation incident on a potassium metal? Work function of potassium is 2.3 eV?
- 7.37 Ultra violet light of wave length 2271 Å from a source irradiates a photo-cell which is made of molybdenum metal. If the stopping potential is 1.3 volt, calculate the work function of the metal. How

would the photo cell respond to a high intensity ( $10^5 \text{ Wm}^{-2}$ ) red light of wavelength  $6328 \text{ \AA}$  produced by He - Ne Laser?

- 7.38 The work function of Iron is  $4.7 \text{ eV}$ . Calculate the cut off frequency and the corresponding cut off wave length for this metal.
- 7.39 For an observer imagined to be moving at a speed of  $36 \times 10^6 \text{ km/hr}$ , length of the rod measures  $1\text{m}$ . Find the length of the rod as measured by a stationary observer.
- 7.40 The time interval measured by an observer at rest is  $2.5 \times 10^{-8}\text{s}$ . What is the time interval as measured by an observer moving with a velocity  $v = 0.73 c$ .
- 7.41 Calculate the rest energy of an electron in MeV (mass of an electron  $9.11 \times 10^{-31} \text{ kg}$ ).
- 7.42 A proton is moving at a speed of  $0.900$  times the velocity of light. Find its kinetic energy in joules and MeV.

#### Answers

- |  |  |                |                |
|--|--|----------------|----------------|
| <b>7.1</b> (a)   | <b>7.2</b> (a)                                   | <b>7.3</b> (b) | <b>7.4</b> (a) |
| <b>7.5</b> (d)   | <b>7.6</b> (d)                                   | <b>7.7</b> (a) | <b>7.8</b> (c) |
| <b>7.9</b> (c)   | <b>7.10</b> (a)                                  |                |                |
| <b>7.31</b> $2.475 \text{ eV}, 0.62 \text{ eV}$                              | <b>7.32</b> $1.354 \text{ eV}, 917.2 \text{ nm}$ |                |                |
| <b>7.33</b> $7.52 \times 10^5 \text{ ms}^{-1}$                               | <b>7.34</b> $15.16 \times 10^{-31} \text{ kg}$   |                |                |
| <b>7.35</b> $4.34 \times 10^{14} \text{ Hz}; 1.42 \times 10^{15} \text{ Hz}$ |  |                |                |
| <b>7.36</b> $0.56 \times 10^{15} \text{ Hz}$                                 |  |                |                |
| <b>7.37</b> $4.166 \text{ eV}$ , As $v_0 > v$ , electrons are not emitted.   |  |                |                |
| <b>7.38</b> $1.1 \times 10^{15} \text{ Hz}; 2.64 \times 10^2 \text{ nm}$     | <b>7.39</b> $1.0006 \text{ m}$                   |                |                |
| <b>7.40</b> $3.658 \times 10^{-8} \text{ s}$                                 | <b>7.41</b> $0.512 \text{ MeV}$                  |                |                |
| <b>7.42</b> $1.955 \times 10^{-10} \text{ J}; 1221.8 \text{ MeV}$            |  |                |                |

## 8. Nuclear Physics

The atomic nucleus was discovered by Earnest Rutherford in 1911. Rutherford's experiment on scattering of alpha particles proved that the mass of the atom and the positive charge is concentrated in a very small central core called nucleus. The dimension of nucleus is much smaller than the overall dimension of the atom. The nucleus is surrounded by orbiting electrons.

### 8.1 Nucleus

The nucleus consists of the elementary particles, protons and neutrons which are known as nucleons. A proton has positive charge of the same magnitude as that of electron and its rest mass is about 1836 times the mass of an electron. A neutron is electrically neutral, whose mass is almost equal to the mass of the proton. The nucleons inside the nucleus are held together by strong attractive forces called nuclear forces.

A nucleus of an element is represented as  ${}_Z X^A$ , where X is the chemical symbol of the element. Z represents the atomic number which is equal to the number of protons and A, the mass number which is equal to the total number of protons and neutrons. The number of neutrons is represented as N which is equal to A-Z. For example, the chlorine nucleus is represented as  ${}_{17}Cl^{35}$ . It contains 17 protons and 18 neutrons.

#### 8.1.1 Classification of nuclei

##### (i) Isotopes

Isotopes are atoms of the same element having the same atomic number Z but different mass number A. The nuclei  ${}_1H^1$ ,  ${}_1H^2$  and  ${}_1H^3$  are the isotopes of hydrogen. In other words isotopes of an element contain the same number of protons but different number of neutrons. As the atoms of isotopes have identical electronic structure, they have identical chemical properties and placed in the same location in the periodic table.

### **(ii) Isobars**

Isobars are atoms of different elements having the same mass number  $A$ , but different atomic number  $Z$ . The nuclei  ${}_8\text{O}^{16}$  and  ${}_7\text{N}^{16}$  represent two isobars. Since isobars are atoms of different elements, they have different physical and chemical properties.

### **(iii) Isotones**

Isotones are atoms of different elements having the same number of neutrons.  ${}_6\text{C}^{14}$  and  ${}_8\text{O}^{16}$  are some examples of isotones.

## **8.1.2 General properties of nucleus**

### **Nuclear size**

According to Rutherford's  $\alpha$ -particle scattering experiment, the distance of the closest approach of  $\alpha$  - particle to the nucleus was taken as a measure of nuclear radius, which is approximately  $10^{-15}\text{m}$ . If the nucleus is assumed to be spherical, an empirical relation is found to hold good between the radius of the nucleus  $R$  and its mass number  $A$ . It is given by

$$R \propto A^{1/3}$$

$$R = r_0 A^{1/3}$$

where  $r_0$  is the constant of proportionality and is equal to  $1.3 \text{ F}$  ( $1 \text{ Fermi, F} = 10^{-15} \text{ m}$ )

### **Nuclear density**

The nuclear density  $\rho_N$  can be calculated from the mass and size of the nucleus.

$$\rho_N = \frac{\text{Nuclear mass}}{\text{Nuclear volume}}$$

$$\text{Nuclear mass} = Am_N$$

where,  $A$  = mass number

and  $m_N$  = mass of one nucleon and is approximately equal to  $1.67 \times 10^{-27} \text{ kg}$

$$\text{Nuclear volume} = \frac{4}{3} \pi R^3 = \frac{4}{3} \pi (r_0 A^{1/3})^3$$



$$\therefore \rho_N = \frac{A m_N}{\frac{4}{3}\pi(r_0 A^{1/3})^3} = \frac{m_N}{\frac{4}{3}\pi r_0^3}$$

Substituting the known values, the nuclear density is calculated as  $1.816 \times 10^{17} \text{ kg m}^{-3}$  which is almost a constant for all the nuclei irrespective of its size.

The high value of the nuclear density shows that the nuclear matter is in an extremely compressed state.

### **Nuclear charge**

The charge of a nucleus is due to the protons present in it. Each proton has a positive charge equal to  $1.6 \times 10^{-19} \text{ C}$ .

$\therefore$  The nuclear charge =  $Ze$ , where  $Z$  is the atomic number.

### **Atomic mass unit**

It is convenient to express the mass of a nucleus in atomic mass unit (amu), though the unit of mass is kg. One atomic mass unit is considered as one twelfth of the mass of carbon atom  ${}_6\text{C}^{12}$ . Carbon of atomic number 6 and mass number 12 has mass equal to 12 amu.

$$1 \text{ amu} = 1.66 \times 10^{-27} \text{ kg}$$

The mass of a proton,  $m_p = 1.007276 \text{ amu}$

This is equal to the difference in mass of the hydrogen atom which is 1.007825 amu and the mass of electron.

The mass of a neutron,  $m_n = 1.008665 \text{ amu}$

The energy equivalence of one amu can be calculated in electron-volt

Einstein's mass energy relation is,  $E = mc^2$

Here,  $m = 1 \text{ amu} = 1.66 \times 10^{-27} \text{ kg}$

$$c = 3 \times 10^8 \text{ ms}^{-1}$$

$$\therefore E = 1.66 \times 10^{-27} \times (3 \times 10^8)^2 \text{ J}$$

One electron-volt (eV) is defined as the energy of an electron when it is accelerated through a potential difference of 1 volt.

$$1 \text{ eV} = 1.6 \times 10^{-19} \text{ coulomb} \times 1 \text{ volt}$$

$$1 \text{ eV} = 1.6 \times 10^{-19} \text{ joule}$$

$$\text{Hence, } E = \frac{1.66 \times 10^{-27} \times (3 \times 10^8)^2}{1.6 \times 10^{-19}} \text{ eV} = 931 \times 10^6 \text{ eV}$$

$$= 931 \text{ million electronvolt} = 931 \text{ MeV}$$

Thus, energy equivalent of 1 amu = 931 MeV

### **Nuclear mass**

As the nucleus contains protons and neutrons, the mass of the nucleus is assumed to be the mass of its constituents.

$$\text{Assumed nuclear mass} = Zm_p + Nm_n,$$

where  $m_p$  and  $m_n$  are the mass of a proton and a neutron respectively. However, from the measurement of mass by mass spectrometers, it is found that the mass of a stable nucleus ( $m$ ) is less than the total mass of the nucleons.

$$\text{i.e. mass of a nucleus, } m < (Zm_p + Nm_n)$$

$$Zm_p + Nm_n - m = \Delta m$$

where  $\Delta m$  is the mass defect

Thus, the difference in the total mass of the nucleons and the actual mass of the nucleus is known as the mass defect.

**Note :** In any mass spectrometer, it is possible to determine only the mass of the atom, which includes the mass of  $Z$  electrons. If  $M$  represents the mass of the atom, then the mass defect can be written as

$$\Delta m = Zm_p + Nm_n + Zm_e - M$$

$$= Zm_H + Nm_n - M$$

where  $m_H$  represents the mass of one hydrogen atom

### **Binding energy**

When the protons and neutrons combine to form a nucleus, the mass that disappears (mass defect,  $\Delta m$ ) is converted into an equivalent amount of energy ( $\Delta mc^2$ ). This energy is called the binding energy of the nucleus.

$$\therefore \text{Binding energy} = [Zm_p + Nm_n - m] c^2$$

$$= \Delta m c^2$$

The binding energy of a nucleus determines its stability against disintegration. In other words, if the binding energy is large, the nucleus is stable and vice versa.

The binding energy per nucleon is

$$\frac{BE}{A} = \frac{\text{Binding energy of the nucleus}}{\text{Total number of nucleons}}$$

It is found that the binding energy per nucleon varies from element to element. A graph is plotted with the mass number A of the nucleus along the X-axis and binding energy per nucleon along the Y-axis (Fig 8.1).

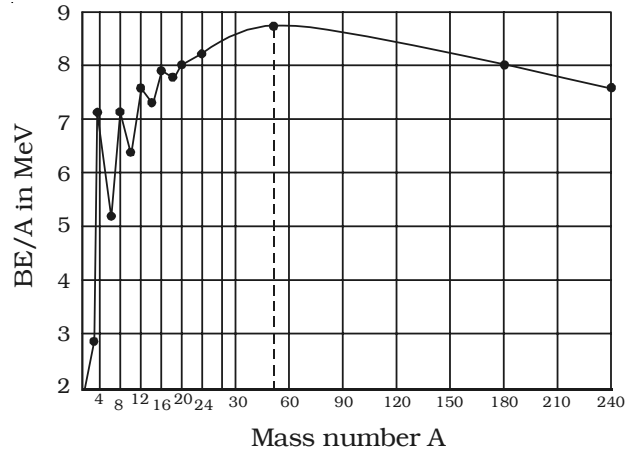

Fig 8.1 Binding energy graph

#### Explanation of binding energy curve

(i) The binding energy per nucleon increases sharply with mass number A upto 20. It increases slowly after A = 20. For A < 20, there exists recurrence of peaks corresponding to those nuclei, whose mass numbers are multiples of four and they contain not only equal but also even number of protons and neutrons. Example:  ${}^2\text{He}^4$ ,  ${}^4\text{Be}^8$ ,  ${}^6\text{C}^{12}$ ,  ${}^8\text{O}^{16}$ , and  ${}^{10}\text{Ne}^{20}$ . The curve becomes almost flat for mass number between 40 and 120. Beyond 120, it decreases slowly as A increases.

(ii) The binding energy per nucleon reaches a maximum of 8.8 MeV at A=56, corresponding to the iron nucleus ( ${}^{56}_{26}\text{Fe}$ ). Hence, iron nucleus is the most stable.

(iii) The average binding energy per nucleon is about 8.5 MeV for nuclei having mass number ranging between 40 and 120. These elements are comparatively more stable and non radioactive.

(iv) For higher mass numbers the curve drops slowly and the BE/A is about 7.6 MeV for uranium. Hence, they are unstable and radioactive.

(v) The lesser amount of binding energy for lighter and heavier nuclei explains nuclear fusion and fission respectively. A large amount of energy will be liberated if lighter nuclei are fused to form heavier one (fusion) or if heavier nuclei are split into lighter ones (fission).

## 8.2 Bainbridge mass spectrometer - Determination of isotopic masses of nuclei

Bainbridge mass spectrometer is an instrument used for the accurate determination of atomic masses. A schematic diagram of this spectrometer is shown in Fig 8.2.

Atoms with one or more electrons removed, have a net positive charge and they become positive ions. A beam of positive ions produced in a discharge tube is collimated into a fine beam by two narrow slits  $S_1$  and  $S_2$ . This fine beam enters into a velocity selector. The velocity selector

allows the ions of a particular velocity to come out of it, by the combined action of an electric and a magnetic field. The velocity selector consists of two plane parallel plates  $P_1$  and  $P_2$ , which produces a uniform electric field  $E$  and an electromagnet, to produce uniform magnetic field  $B$  (represented by the dotted circle). These two fields are at right angles to each other and to the direction of the beam.

The electric field and magnetic field are so adjusted that the deflection produced by one field is nullified by the other, so that the ions do not suffer any deflection within the velocity selector. Let  $E$  and  $B$  be the electric field intensity and magnetic induction respectively and  $q$  be the charge of the positive ion. The force exerted by the electric field is equal to  $qE$  and the force exerted by the magnetic field is equal to  $Bqv$  where  $v$  is the velocity of the positive ion.

$$qE = Bqv$$

$$v = E/B$$

Only those ions having this velocity  $v$ , pass out of the velocity selector and then through the slit  $S_3$ , to enter the evacuated

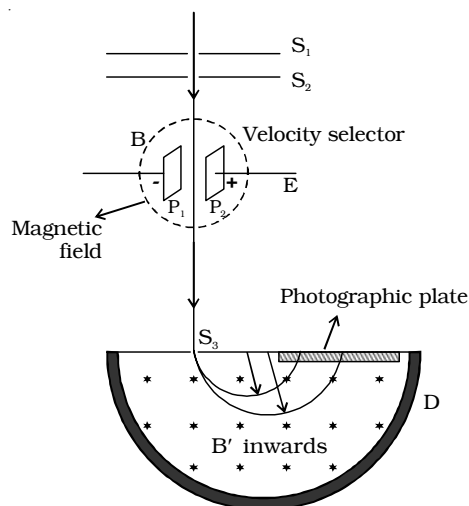

Fig 8.2 Bainbridge mass spectrometer

chamber D. These positive ions having the same velocity are subjected to another strong uniform magnetic field of induction  $B'$  at right angles to the plane of the paper acting inwards. These ions are deflected along circular path of radius  $R$  and strike the photographic plate. The force due to magnetic field  $B'qv$  provides the centripetal force.

$$B'qv = \frac{mv^2}{R}$$

$$m = \frac{B'qR}{v}$$

Substituting  $v = E/B$

$$m = \frac{BB'qR}{E}$$

Ions with different masses trace semi-circular paths of different radii and produce dark lines on the plate. The distance between the opening of the chamber and the position of the dark line gives the diameter  $2R$  from which radius  $R$  can be calculated.

Since  $q$ ,  $B$ ,  $B'$ ,  $E$  and  $R$  are known, the mass of the positive ions and hence isotopic masses can be calculated.

### 8.3 Nuclear force

The nucleus of an atom consists of positively charged protons and uncharged neutrons. According to Coulomb's law, protons must repel each other with a very large force, because they are close to each other and hence the nucleus must be broken into pieces. But this does not happen. It means that, there is some other force in the nucleus which overcomes the electrostatic repulsion between positively charged protons and binds the protons and neutrons inside the nucleus. This force is called nuclear force.

(i) Nuclear force is charge independent. It is the same for all the three types of pairs of nucleons (n-n), (p-p) and (n-p). This shows that nuclear force is not electrostatic in nature.

(ii) Nuclear force is the strongest known force in nature.

(iii) Nuclear force is not a gravitational force. Nuclear force is about  $10^{40}$  times stronger than the gravitational force.

(iv) Nuclear force is a short range force. It is very strong between two nucleons which are less than  $10^{-15}$  m apart and is almost negligible at a distance greater than this. On the other hand electrostatic, magnetic and gravitational forces are long range forces that can be felt easily.

Yukawa suggested that the nuclear force existing between any two nucleons may be due to the continuous exchange of particles called mesons, just as photons, the exchange particle in electromagnetic interactions.

However, the present view is that the nuclear force that binds the protons and neutrons is not a fundamental force of nature but it is secondary.

#### **8.4 Radioactivity**

The phenomenon of radioactivity was discovered by Henri Becquerel in 1896. He found that a photographic plate wrapped in a black paper was affected by certain penetrating radiations emitted by uranium salt. Rutherford showed later that the radiations from the salt were capable of ionising a gas. The current produced due to the ions was taken as a measure of activity of the compound.

A few years later Madame Marie Curie and her husband Piere Curie discovered the highly radioactive elements radium and polonium. The activity of the material has been shown to be the result of the three different kinds of radiations,  $\alpha$ ,  $\beta$  and  $\gamma$ .

The phenomenon of spontaneous emission of highly penetrating radiations such as  $\alpha$ ,  $\beta$  and  $\gamma$  rays by heavy elements having atomic number greater than 82 is called radioactivity and the substances which emit these radiations are called radioactive elements.

The radioactive phenomenon is spontaneous and is unaffected by any external agent like temperature, pressure, electric and magnetic fields etc.

### 8.4.1 Alpha, beta and gamma rays

The existence of the three distinct types of radiations,  $\alpha$ ,  $\beta$  and  $\gamma$ -rays can be easily found by the following experiment. A small amount of radium (R) is placed at the bottom of a small hole drilled in a lead block, which is kept in an evacuated chamber (Fig. 8.3).

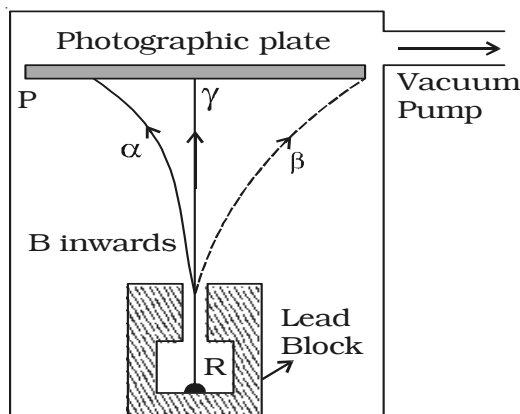

Fig 8.3 Radioactivity

A photographic plate is placed at a short distance above the lead block. A strong magnetic field is applied

at right angles to the plane of the paper and acting inwards. Three distinct traces can be seen on the photographic plate when it is developed. The trace towards left is due to positively charged particles. They are named  $\alpha$ -particles. The trace towards the right is due to negatively charged particles. They are named  $\beta$ -particles. The undeviated trace is due to neutral radiations which are called  $\gamma$ -rays. If an electric field is applied, the  $\alpha$ -rays are deflected towards the negative plate,  $\beta$ -rays towards the positive plate and  $\gamma$ -rays are not deflected.

#### Properties of $\alpha$ -rays

(i) An  $\alpha$  - particle is a helium nucleus consisting of two protons and two neutrons. It carries two units of positive charge.

(ii) They move along straight lines with high velocities.

(iii) They are deflected by electric and magnetic fields.

(iv) They produce intense ionisation in the gas through which they pass. The ionising power is 100 times greater than that of  $\beta$ -rays and 10,000 times greater than that of  $\gamma$ -rays.

(v) They affect photographic plates.

(vi) They are scattered by heavy elements like gold.

(vii) They produce fluorescence when they fall on substances like zinc sulphide or barium platinocyanide.

### **Properties of $\beta$ - rays**

(i)  $\beta$ -particles carry one unit of negative charge and mass equal to that of electron. Therefore, they are nothing but electrons.

(ii) The  $\beta$ -particles emitted from a source have velocities over the range of  $0.3c$  to  $0.99c$ , where  $c$  is the velocity of light.

(iii) They are deflected by electric and magnetic fields.

(iv) The ionisation power is comparatively low

(v) They affect photographic plates.

(vi) They penetrate through thin metal foils and their penetrating power is greater than that of  $\alpha$ -rays

(vii) They produce fluorescence when they fall on substances like barium platinocyanide.

### **Properties of $\gamma$ - rays**

(i) They are electromagnetic waves of very short wavelength.

(ii) They are not deflected by electric and magnetic fields.

(iii) They travel with the velocity of light.

(iv) They produce very less ionisation.

(v) They affect photographic plates.

(vi) They have a very high penetrating power, greater than that of  $\beta$ -rays.

(vii) They produce fluorescence.

(viii) They are diffracted by crystals in the same way like X-rays are diffracted.

### **8.5 Radioactive displacement law**

During a radioactive disintegration, the nucleus which undergoes disintegration is called a parent nucleus and that which remains after the disintegration is called a daughter nucleus. In 1913, Soddy and Fajan framed the displacement laws governing radioactivity.

#### **$\alpha$ -decay**

When a radioactive nucleus disintegrates by emitting an  $\alpha$ -particle, the atomic number decreases by two and mass number decreases by four. The  $\alpha$ -decay can be expressed as

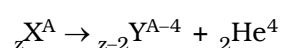



Example : Radium ( ${}_{88}\text{Ra}^{226}$ ) is converted to radon ( ${}_{86}\text{Rn}^{222}$ ) due to  $\alpha$ -decay

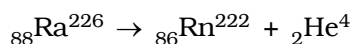

### **$\beta$ -decay**

When a radioactive nucleus disintegrates by emitting a  $\beta$ -particle, the atomic number increases by one and the mass number remains the same.  $\beta$ -decay can be expressed as

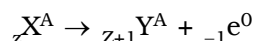

Example : Thorium ( ${}_{90}\text{Th}^{234}$ ) is converted to protoactinium ( ${}_{91}\text{Pa}^{234}$ ) due to  $\beta$ -decay

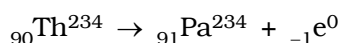

At a time, either  $\alpha$  or  $\beta$ -particle is emitted. Both  $\alpha$  and  $\beta$  particles are not emitted during a single decay.

### **$\gamma$ -decay**

When a radioactive nucleus emits  $\gamma$ -rays, only the energy level of the nucleus changes and the atomic number and mass number remain the same.

During  $\alpha$  or  $\beta$ -decay, the daughter nucleus is mostly in the excited state. It comes to ground state with the emission of  $\gamma$ -rays.

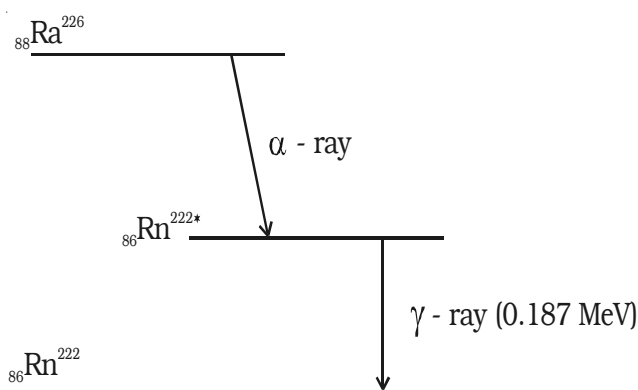

Fig 8.4 Gamma decay

Example : During the radioactive disintegration of radium ( ${}_{88}\text{Ra}^{226}$ ) into radon ( ${}_{86}\text{Rn}^{222}$ ), gamma ray of energy 0.187 MeV is emitted, when radon returns from the excited state to the ground state (Fig 8.4).

### **Radioactive law of disintegration**

Rutherford and Soddy found that the rate of disintegration is independent of physical and chemical conditions. The rate of disintegration at any instant is directly proportional to the number of

atoms of the element present at that instant. This is known as radioactive law of disintegration.

Let  $N_0$  be the number of radioactive atoms present initially and  $N$ , the number of atoms at a given instant  $t$ . Let  $dN$  be the number of atoms undergoing disintegration in a small interval of time  $dt$ . Then the rate of disintegration is

$$-\frac{dN}{dt} \propto N$$

$$\frac{dN}{dt} = -\lambda N \quad \dots(1)$$

where  $\lambda$  is a constant known as decay constant or disintegration constant. The negative sign indicates that  $N$  decreases with increase in time.

Equation (1) can be written as

$$\frac{dN}{N} = -\lambda dt$$

Integrating,  $\log_e N = -\lambda t + C \quad \dots(2)$

where  $C$  is a constant of integration.

At  $t = 0, N = N_0$

$\therefore \log_e N_0 = C$

Substituting for  $C$ , equation (2) becomes

$$\log_e N = -\lambda t + \log_e N_0$$

$$\log_e \left( \frac{N}{N_0} \right) = -\lambda t$$

$$\frac{N}{N_0} = e^{-\lambda t}$$

$$N = N_0 e^{-\lambda t} \quad \dots(3)$$

Equation (3) shows that the number of atoms of a radioactive substance decreases exponentially with increase in time (Fig 8.5).

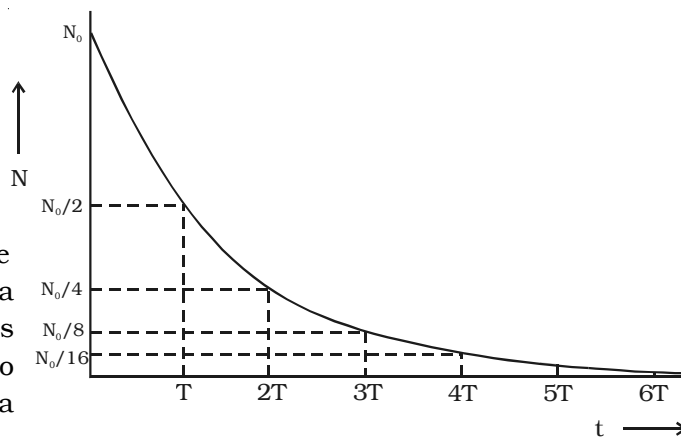

Fig 8.5 Radioactive law of disintegration

Initially the disintegration takes place at a faster rate. As time increases,  $N$  gradually decreases exponentially. Theoretically, an infinite time is required for the complete disintegration of all the atoms.

### **Half life period**

Since all the radioactive elements have infinite life period, in order to distinguish the activity of one element with another, half life period and mean life period are introduced.

The half life period of a radioactive element is defined as the time taken for one half of the radioactive element to undergo disintegration.

From the law of disintegration

$$N = N_0 e^{-\lambda t}$$

Let  $T_{1/2}$  be the half life period. Then, at  $t = T_{1/2}$ ,  $N = \frac{N_0}{2}$

$$\therefore \frac{N_0}{2} = N_0 e^{-\lambda T_{1/2}}$$

$$\log_e 2 = \lambda T_{1/2}$$

$$T_{1/2} = \frac{\log_e 2}{\lambda} = \frac{\log_{10} 2 \times 2.3026}{\lambda} = \frac{0.6931}{\lambda}$$

The half life period is inversely proportional to its decay constant.

The concept of half time period can be understood from Fig 8.5.

For a radioactive substance, at the end of  $T_{1/2}$ , 50% of the material remain unchanged. After another  $T_{1/2}$  i.e., at the end of  $2 T_{1/2}$ , 25% remain unchanged. At the end of  $3 T_{1/2}$ , 12.5% remain unchanged and so on.

### **Mean life**

When the radioactive substance is undergoing disintegration, the atom which disintegrates at first has zero life and that disintegrates at last has infinite life. The actual life of each atom ranges from zero to infinity.

The mean life of a radioactive substance is defined as the ratio

**Note :**

Fraction of radioactive substance left undecayed is,  $\frac{N}{N_0} = \left(\frac{1}{2}\right)^n$  where  $n$  is the number of half lives.

$$n = \frac{\text{Total time}}{\text{Half life}}$$

of total life time of all the radioactive atoms to the total number of atoms in it.

$$\therefore \text{Mean life} = \frac{\text{Sum of life time of all the atoms}}{\text{Total number of atoms}}$$

The mean life is calculated from the law of disintegration and it can be shown that the mean life is the reciprocal of the decay constant.

$$\tau = \frac{1}{\lambda}$$

The half life and mean life are related as

$$T_{1/2} = \frac{0.6931}{\lambda} = 0.6931 \tau$$

### **Activity**

The activity of a radioactive substance is defined as the rate at which the atoms decay. If  $N$  is the number of atoms present at a certain time  $t$ , the activity  $R$  is given by

$$R = -\frac{dN}{dt}$$

The unit of activity is becquerel named after the scientist Henri Becquerel

$$\therefore 1 \text{ becquerel} = 1 \text{ disintegration per second}$$

The activity of a radioactive substance is generally expressed in curie. Curie is defined as the quantity of a radioactive substance which gives  $3.7 \times 10^{10}$  disintegrations per second or  $3.7 \times 10^{10}$  becquerel. This is equal to the activity of one gram of radium.

### **8.6 Neutron - Discovery**

In 1930, two German Physicists Bothe and Becker found that when beryllium was bombarded with  $\alpha$  -particles, a highly penetrating radiation was emitted. This radiation was capable of traversing through a thick layer of lead and was unaffected by electric and magnetic fields. At that time, the radiation was thought to be  $\gamma$ -rays.

In 1932, Irene Curie and F. Joliot found that those radiations were able to knock out protons from paraffin and similar substances that are rich in hydrogen. Chadwick in the same year discovered that the emitted radiation consists of particles of mass nearly equal to proton and no charge. He called them as neutrons. The above reaction can be written as

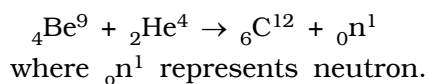

### 8.6.1 Properties of neutrons

(i) Neutrons are the constituent particles of all nuclei, except hydrogen.

(ii) Neutrons are neutral particles with no charge and mass slightly greater than that of protons. Hence, they are not deflected by electric and magnetic fields.

(iii) Neutrons are stable inside the nucleus. But outside the nucleus they are unstable. The free neutron decays with an emission of proton, electron and antineutrino, with half life of 13 minutes.

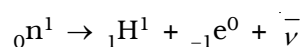

(iv) As neutrons are neutral, they can easily penetrate any nucleus.

(v) Neutrons are classified according to their kinetic energy as (a) slow neutrons and (b) fast neutrons. Both are capable of penetrating a nucleus causing artificial transmutation of the nucleus.

Neutrons with energies from 0 to 1000 eV are called slow neutrons. The neutrons with an average energy of about 0.025 eV in thermal equilibrium are called thermal neutrons.

Neutrons with energies in the range between 0.5 MeV and 10 MeV are called fast neutrons. In nuclear reactors, fast neutrons are converted into slow neutrons using moderators.

### 8.7 Artificial radioactivity

Artificial radioactivity or induced radioactivity was discovered by Irene Curie and F. Joliot in 1934. This is also known as man-made radioactivity. The phenomenon by which even light elements are made radioactive by artificial or induced methods is called artificial radioactivity.

Curie and Joliot showed that when lighter elements such as boron and aluminium were bombarded with  $\alpha$ -particles, there was a continuous emission of radioactive radiations, even after the  $\alpha$ -source had been removed. They showed that the radiation was due to the emission of a particle carrying one unit positive charge with mass equal to that of an electron. This particle is known as positron and the reaction is

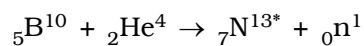

The nitrogen atom is radioactive and decays with a half life of about 10.1 minutes into a stable isotope of carbon with the emission of a positron

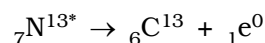

In the case of Aluminium,

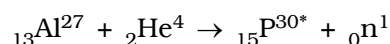

Radio-phosphorous decays into a stable isotope of silicon with the emission of a positron. The half life of radioactive phosphorous is about 3 minutes.

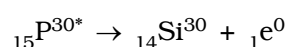

Artificial radioactivity follows the same laws of natural radioactivity. Artificial radioactive elements emit electrons, positrons, neutrons and  $\gamma$  rays.

### **Production of artificial radio-isotopes**

(i) Artificial radio-isotopes are produced by placing the target element in the nuclear reactor, where plenty of neutrons are available.



(ii) Another method of production of artificial radio-isotope is to bombard the target element with particles from particle accelerators like cyclotron.

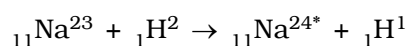

### **8.7.1 Applications of radio-isotopes**

The radio-isotopes have wide applications in medicine, agriculture, industry and research. A radio-isotope is added to a particular system and the course of the isotope is studied to understand the system.

#### **(i) Medical applications**

In medical field, radio-isotopes are used both in diagnosis and therapy. Radio cobalt ( $\text{Co}^{60}$ ) emitting  $\gamma$ -rays is used in the treatment of cancer. Gamma rays destroy cancer cells to a greater extent.

Radio-sodium ( $\text{Na}^{24}$ ) is used to detect the presence of blocks in blood vessels, to check the effective functioning of heart in pumping blood and maintaining circulation. Radio-iodine ( $\text{I}^{131}$ ) is used in the detection of the nature of thyroid gland and also for treatment. Radio-iodine is also used to locate brain tumours.

Radio-iron ( $\text{Fe}^{59}$ ) is used to diagnose anaemia. An anaemic patient retains iron in the blood longer than normal patient.

Radio-phosphorous ( $\text{P}^{32}$ ) is used in the treatment of skin diseases.

**(ii) Agriculture**

In agriculture, radio-isotopes help to increase the crop yields. Radio-phosphorous ( $\text{P}^{32}$ ) incorporated with phosphate fertilizer is added to the soil. The plant and soil are tested from time to time. Phosphorous is taken by the plant for its growth and radio-phosphorous is found to increase the yield.

Sprouting and spoilage of onions, potatoes, grams etc. are prevented by exposure to a very small amount of radiation. Certain perishable cereals remain fresh beyond their normal life span when exposed to radiation.

**(iii) Industry**

In Industry, the lubricating oil containing radio-isotopes is used to study the wear and tear of the machinery.

**(iv) Molecular biology**

In molecular biology radio-isotopes are used in sterilising pharmaceutical and surgical instruments.

**(v) Radio-carbon dating**

In the upper atmosphere,  $\text{C}^{14}$  is continually formed from  $\text{N}^{14}$  due to the bombardment by neutrons produced from cosmic rays.

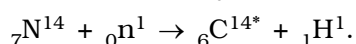

The  $\text{C}^{14}$  is radioactive with half life of 5570 years.

The production and the decay of  $\text{C}^{14}$  are in equilibrium in atmosphere. The ratio of  $\text{C}^{14}$  and  $\text{C}^{12}$  atoms in atmosphere is  $1 : 10^6$ . Hence, carbon dioxide present in the atmosphere contains a small portion of  $\text{C}^{14}$ .

Living things take  $\text{C}^{14}$  from food and air. However with death, the intake of  $\text{C}^{14}$  stops, and the  $\text{C}^{14}$  that is already present begins to decay. Hence the amount of  $\text{C}^{14}$  in the sample will enable the calculation of time of death i.e, the age of the specimen could be estimated. This is called radio-carbon dating. This method is employed in the dating of wooden implements, leather clothes, charcoal used in oil paintings, mummies and so on.

### **8.7.2 Biological hazards of nuclear radiations**

When  $\gamma$ -ray or any high energy nuclear particle passes through human beings, it disrupts the entire normal functioning of the biological system and the effect may be either pathological or genetic.

The biological effects of nuclear radiation can be divided into three groups

- (i) Short term recoverable effects
- (ii) long term irrecoverable effects and
- (iii) genetic effect

The extent to which the human organism is damaged depends upon (i) the dose and the rate at which the radiation is given and (ii) the part of the body exposed to it.

Smaller doses of radiation exposure produce short term effects such as skin disorder and loss of hair.

If the exposure is 100 R\*, it may cause diseases like leukemia (death of red blood corpuscle in the blood) or cancer. When the body is exposed to about 600 R, ultimately it causes death. Safe limit of receiving the radiations is about 250 milli roentgen per week.

The genetic damage is still worse. The radiations cause injury to genes in the reproductive cells. This gives rise to mutations which pass on from generation to generation.

The following precautions are to be taken for those, who are working in radiation laboratories.

- (1) Radioactive materials are kept in thick-walled lead container.
- (2) Lead aprons and lead gloves are used while working in hazardous area.
- (3) All radioactive samples are handled by a remote control process.
- (4) A small micro-film badge is always worn by the person and it is checked periodically for the safety limit of radiation.

---

\* The radiation exposure is measured by the unit called roentgen (R). One roentgen is defined as the quantity of radiation which produces  $1.6 \times 10^{12}$  pairs of ions in 1 gram of air.



### 8.7.3 Artificial transmutation

Artificial transmutation is the conversion of one element into another by artificial methods. The first successful artificial transmutation was carried out by Rutherford. When nitrogen was bombarded with  $\alpha$ -particles of sufficient energy, a rare isotope of oxygen ( ${}_8\text{O}^{17}$ ) and a proton were formed.

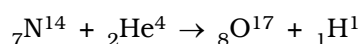

This process is called nuclear reaction.

In a nuclear reaction, the sum of initial atomic numbers (charges) is equal to the sum of the final atomic numbers, i.e conservation of charges is satisfied. In the same way, conservation of nucleons is also satisfied. But the initial rest mass is not equal to the final rest mass. The energy equivalence of the difference between the rest masses is equal to the nuclear reaction energy  $Q$ . The nuclear reaction can be written as

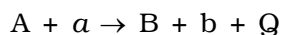

where  $A$  is the target nucleus and  $a$ , the bombarding particle.  $B$  and  $b$  are the product nucleus and particle.

### 8.7.4 Particle accelerators

A particle accelerator is a device used to accelerate the charged particles, which are required in the study of artificial transmutation of elements. Hence the accelerator is the basic device in high energy particle physics.

Accelerators can be divided broadly into two types.

(i) The first type belongs to electrostatic accelerators in which charged particles are accelerated by applying a constant potential difference. The final energy is determined by the amount of the potential difference. The Cockcroft–Walton and Van de Graaff generators belong to this class. These accelerators can accelerate particles only upto a few million electron-volts.

(ii) The second type is the cyclic or synchronous accelerator, which accelerate particles in multiple steps imparting a small energy in each successive step. Example : Linear accelerator, cyclotron, betatron, synchrocyclotron and synchrotron. They can accelerate particles to

energy of the order of  $10^9$  eV (GeV), of course, with each machine having its own energy limit.

The action of Van de Graaff generator and cyclotron have been already dealt in previous chapters.

### 8.8 Geiger - Muller counter

Geiger - Muller counter is used to measure the intensity of the radioactive radiation. When nuclear radiations pass through gas, ionisation is produced. This is the principle of this device.

#### Construction

The G.M tube consists of a metal tube with glass envelope (C) acting as the cathode and a fine tungsten wire (W) along the axis of the tube, which acts as anode (Fig 8.6). The tube is well insulated from the anode wire.

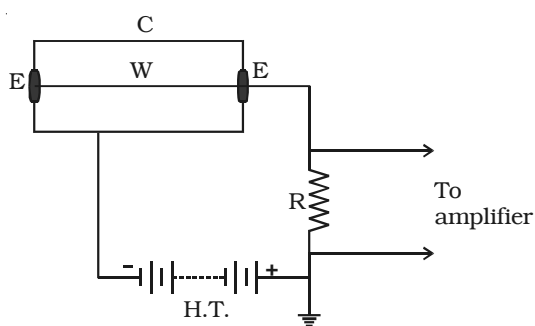

Fig 8.6 G.M Counter

The tube is filled with an inert gas like argon at a low pressure. One end is fitted with a thin mica sheet and this end acts as a window through which radiations enter the tube. A high potential difference of about 1000 V is applied between the electrodes through a high resistance R of about 100 mega ohm.

#### Operation

When an ionising radiation enters the counter, primary ionisation takes place and a few ions are produced. These ions are accelerated with greater energy due to the high potential difference and they cause further ionisation and these ions are multiplied by further collisions. Thus an avalanche of electrons is produced in a short interval of time. This avalanche of electrons on reaching the anode generates a current pulse, which when passing through R develops a potential difference. This is amplified by electronic circuits and is used to operate an electronic counter. The counts in the counter is directly proportional to the intensity of the ionising radiation.

The ionisation of the gas is independent of the type of the incident radiation. Hence, G.M. counter does not distinguish the type of radiation that enters the chamber.

Wilson's cloud chamber is another type of particle detector. This was the first instrument to record the visual observation of the tracks of the charged particles, when they pass through matter.

### 8.9 Nuclear fission

In 1939, German scientists Otto Hahn and F. Strassman discovered that when uranium nucleus is bombarded with a neutron, it breaks up into two fragments of comparable masses with the release of energy.

The process of breaking up of the nucleus of a heavier atom into two fragments with the release of large amount of energy is called nuclear fission. The fission is accompanied of the release of neutrons. The fission reactions with  ${}_{92}\text{U}^{235}$  are represented as

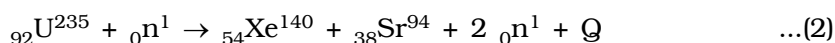
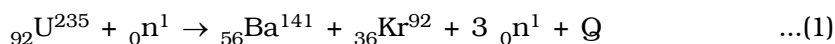

In the above examples the fission reaction is taking place with the release of 3 neutrons and 2 neutrons. On an average 2.5 neutrons per fission are actually released. Of the many possible fission reactions of  ${}_{92}\text{U}^{235}$ , the reaction given in equation (1) is the most favourable.

#### **Energy released in fission**

Let us calculate the amount of energy released during the fission of  ${}_{92}\text{U}^{235}$  with a neutron. The fission reaction is

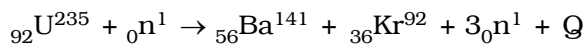

$$\text{Mass of } {}_{92}\text{U}^{235} = 235.045733 \text{ amu}$$

$$\text{Mass of } {}_0\text{n}^1 = 1.008665 \text{ amu}$$

$$\text{Total mass of the reactant} = 236.054398 \text{ amu}$$

$$\text{Mass of } {}_{56}\text{Ba}^{141} = 140.9177 \text{ amu}$$

$$\text{Mass of } {}_{36}\text{Kr}^{92} = 91.8854 \text{ amu}$$

$$\text{Mass of 3 neutrons} = 3.025995 \text{ amu}$$

$$(3 \times 1.008665)$$

$$\text{Total mass of the products} = 235.829095 \text{ amu}$$

$$\therefore \text{Mass defect} = 236.054398 - 235.829095 = 0.225303 \text{ amu}$$

$$\text{As, } 1 \text{ amu} = 931 \text{ MeV, energy released in a fission} =$$

$$0.225303 \times 931 \approx 200 \text{ MeV}$$

Niels Bohr and John A. Wheeler explained the nuclear fission process with the help of liquid drop model. A liquid drop has a spherical shape due to surface tension. On applying external force the sphere changes into ellipsoid, which may change into a dumb bell shape when the force is larger. This may break at the narrow end into two portions.

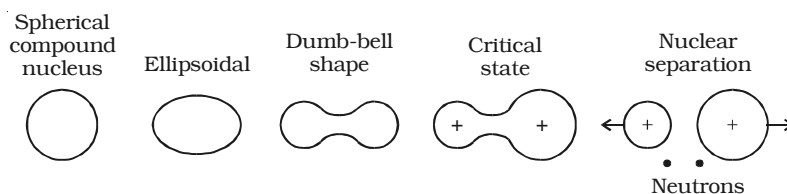

*Fig 8.7 Bohr – Wheeler’s explanation of Nuclear fission*

In the same way, when the heavier nucleus absorbs a neutron, a compound nucleus is formed and is left in an excited state. The excitation energy sets up a series of rapid oscillations. The compound nucleus undergoes distortion from spherical to dumb bell shape. Each portion of the dumb bell has a positive charge and one repels the other. This results in fission and the formation of fission fragments (Fig 8.7)

### **8.9.1 Chain reaction**

Consider a neutron causing fission in a uranium nucleus producing three neutrons. The three neutrons in turn may cause fission in three uranium nuclei producing nine neutrons. These nine neutrons in turn may produce twenty seven neutrons and so on. A chain reaction is a self propagating process in which the number of neutrons goes on multiplying rapidly almost in a geometrical progression.

Two types of chain reactions are possible. In the uncontrolled chain reaction, the number of neutrons multiply indefinitely and the entire amount of energy is released within a fraction of a second. This type of chain reaction takes place in atom bombs.

In the controlled chain reaction the number of fission producing neutron is kept constant and is always equal to one. The reaction is sustained in a controlled manner (Fig 8.8). Controlled chain reaction is taking place in a nuclear reactor.

When a thermal neutron bombards  $U^{235}$  nucleus, it breaks into two fission fragments and three fast neutrons (Fig 8.8). One neutron may escape and one neutron may be captured by  $U^{238}$  which decays to

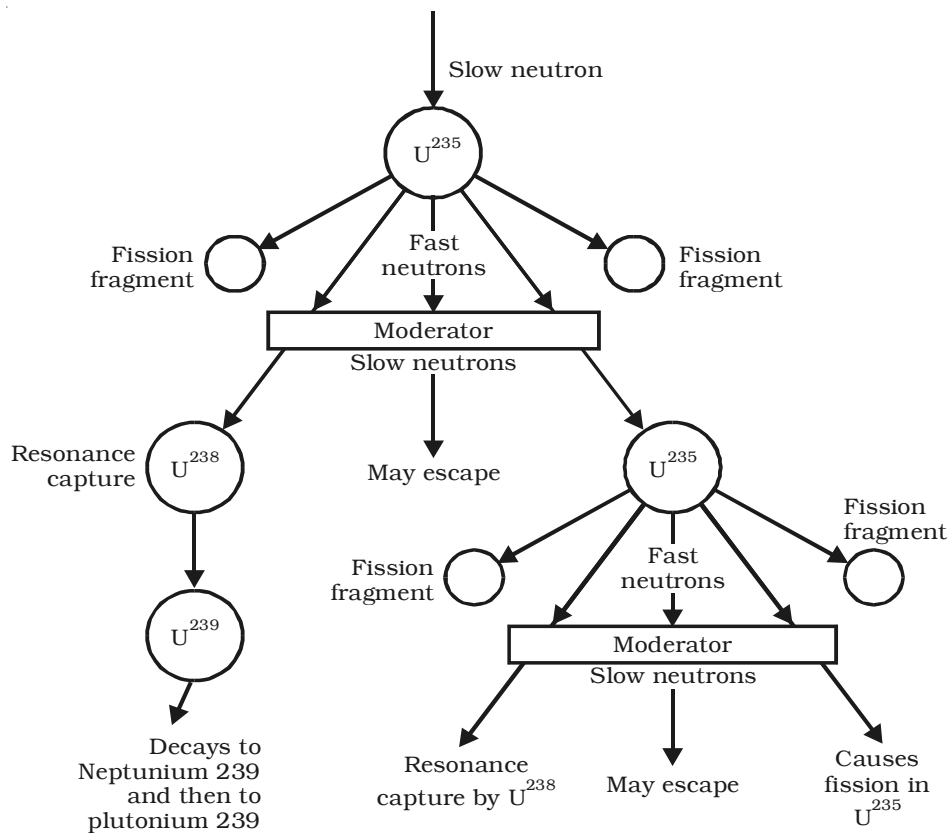

Fig 8.8 Controlled chain reaction

$\text{Np}^{239}$  and then to  $\text{Pu}^{239}$ . One neutron is available for carrying out chain reaction. The chain reaction is possible, only when the loss of neutrons is less than the neutrons produced.

### Critical size

Critical size of a system containing a fissile material is defined as the minimum size in which atleast one neutron is available for further fission reaction. The mass of the fissile material at the critical size is called critical mass. The chain reaction is not possible if the size is less than the critical size.

### 8.9.2 Atom bomb

Atom bomb is based on the principle of uncontrolled fission chain reaction. Natural uranium consists of 99.28% of  $\text{U}^{238}$  and 0.72% of  $\text{U}^{235}$ .  $\text{U}^{238}$  is fissionable only by fast neutrons. Hence, it is essential in

a bomb that either  $U^{235}$  or  $Pu^{239}$  should be used, because they are fissionable by neutrons of all energies.

An atom bomb consists of two hemispheres of  $U^{235}$  (or  ${}_{94}Pu^{239}$ ), each smaller than the critical size and are kept apart by a separator aperture (Fig 8.9).

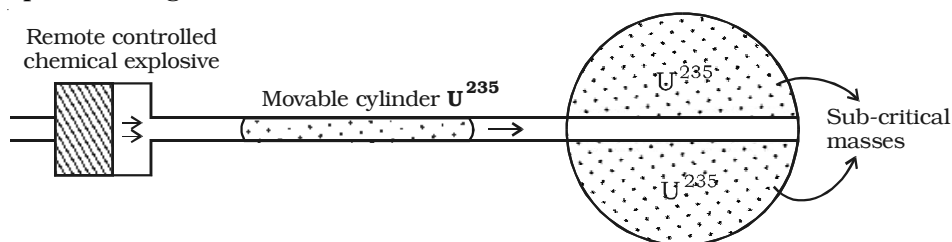

Fig 8.9 Atom bomb

When the bomb has to be exploded, a third well fitting cylinder of  $U^{235}$  (or  ${}_{94}Pu^{239}$ ) whose mass is also less than the critical mass, is propelled so that it fuses together with the other two pieces. Now the total quantity is greater than the critical mass and an uncontrolled chain reaction takes place resulting in a terrific explosion.

The explosion of an atom bomb releases tremendous amount of energy in the form of heat, light and radiation. Temperature of millions of degree celsius and pressure of millions of atmosphere are produced. Such explosions produce shock waves. The release of dangerously radioactive  $\gamma$ -rays, neutrons and radioactive materials produce a health hazards over the surroundings for a long time. These bombs were used in world war II and were exploded over Hiroshima and Nagasaki in Japan. We are quite familiar with the amount of destruction and hazard.

### 8.9.3 Nuclear reactor

A nuclear reactor is a device in which the nuclear fission reaction takes place in a self sustained and controlled manner. The first nuclear reactor was built in 1942 at Chicago USA.

Depending on the purpose for which the reactors are used, they may be calssified into research reactors, production reactors and power reactors. Research reactors are used primarily to supply neutrons for research purpose and for production of radio-isotopes. The purpose of production reactors is to convert fertile (non-fissile but abundant) material into fissile material. The power reactor converts nuclear fission

energy into electric power. The power reactors can be further classified into boiling water reactor, pressurised water reactor, pressurised heavy water reactor and fast breeder reactor depending upon the choice of the moderator and the coolant used.

Numerous reactors of different designs have been constructed all over the world for a variety of purposes, but there exists a number of general features common to all the reactors. The schematic diagram of a nuclear reactor is shown in Fig 8.10.

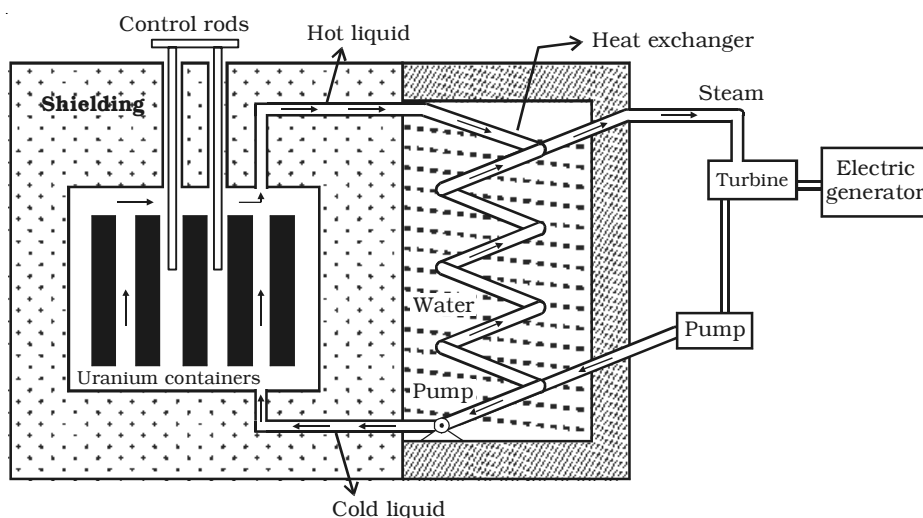

Fig 8.10 Nuclear reactor

**(i) Fissile material or fuel**

The fissile material or nuclear fuel generally used is  ${}_{92}\text{U}^{235}$ . But this exists only in a small amount (0.7%) in natural uranium. Natural uranium is enriched with more number of  ${}_{92}\text{U}^{235}$  (2 – 4%) and this low enriched uranium is used as fuel in some reactors. Other than  $\text{U}^{235}$ , the fissile isotopes  $\text{U}^{233}$  and  $\text{Pu}^{239}$  are also used as fuel in some of the reactors.

In the pressurised heavy water reactors (PHWR) built in our country, natural uranium oxide is used as fuel. Tiny pellets of uranium oxide are packed in thin tubes of zirconium alloy and sealed to form a fuel rod. Nineteen such rods are tied together to form a fuel bundle. The reactor vessel which goes by the name ‘Calandria’ has about three hundred tubes passing through it. The fuel bundles are placed in these

tubes. The part of the reactor vessel which contains the fuel rods is known as reactor core.

In the pressurised light water reactors (PWR), low enriched uranium is used. In the fast breeder test reactor (FBTR) at Kalpakkam, a mixture of the carbides of uranium and plutonium is used as fuel. The fuel of the prototype fast breeder reactor (PFBR) that is being built at Kalpakkam, is a mixture of oxides of plutonium and uranium. In the fast breeder reactors, the fuel pellets are packed in special stainless steel tubes to withstand the high temperature. Kamini [Kalpakkam mini reactor] is the only operating reactor in the world which uses  ${}_{92}\text{U}^{233}$  as fuel. In this reactor, the fuel is an alloy of uranium and aluminium and is in the form of plates.

### **(ii) Moderator**

The function of a moderator is to slow down fast neutrons produced in the fission process having an average energy of about 2 MeV to thermal neutrons with an average energy of about 0.025 eV, which are in thermal equilibrium with the moderator. Ordinary water and heavy water are the commonly used moderators. A good moderator slows down neutrons by elastic collisions and it does not remove them by absorption. The moderator is present in the space between the fuel rods in a channel. Graphite is also used as a moderator in some countries.

In fast breeder reactors, the fission chain reaction is sustained by fast neutrons and hence no moderator is required.

### **(iii) Neutron source**

A source of neutron is required to initiate the fission chain reaction for the first time. A mixture of beryllium with plutonium or radium or polonium is commonly used as a source of neutron.

### **(iv) Control rods**

The control rods are used to control the chain reaction. They are very good absorbers of neutrons. The commonly used control rods are made up of elements like boron or cadmium. The control rods are inserted into the core and they pass through the space in between the fuel tubes and through the moderator. By pushing them in or pulling out, the reaction rate can be controlled. In our country, all the power reactors use boron carbide ( $\text{B}_4\text{C}$ ), a ceramic material as control rod.



### **(v) The cooling system**

The cooling system removes the heat generated in the reactor core. Ordinary water, heavy water and liquid sodium are the commonly used coolants. A good coolant must possess large specific heat capacity and high boiling point. The coolant passes through the tubes containing the fuel bundle and carries the heat from the fuel rods to the steam generator through heat exchanger. The steam runs the turbines to produce electricity in power reactors.

The coolant and the moderator are the same in the PHWR and PWR. In fast breeder reactors, liquid sodium is used as the coolant. A high temperature is produced in the reactor core of the fast breeder reactors. Being a metal substance, liquid sodium is a very good conductor of heat and it remains in the liquid state for a very high temperature as its boiling point is about 1000° C.

### **(vi) Neutron reflectors**

Neutron reflectors prevent the leakage of neutrons to a large extent, by reflecting them back. In pressurised heavy water reactors the moderator itself acts as the reflector.

In the fast breeder reactors, the reactor core is surrounded by depleted uranium (uranium which contains less than 0.7% of  ${}_{92}\text{U}^{235}$ ) or thorium ( ${}_{90}\text{Th}^{232}$ ) which acts as neutron reflector. Neutrons escaping from the reactor core convert these materials into  $\text{Pu}^{239}$  or  $\text{U}^{233}$  respectively.

### **(vii) Shielding**

As a protection against the harmful radiations, the reactor is surrounded by a concrete wall of thickness about 2 to 2.5 m.

### **Breeder reactor**

${}_{92}\text{U}^{238}$  and  ${}_{90}\text{Th}^{232}$  are not fissile materials but are abundant in nature. In the reactor, these can be converted into a fissile material  ${}_{94}\text{Pu}^{239}$  and  ${}_{92}\text{U}^{233}$  respectively by absorption of neutrons. The process of producing more fissile material in a reactor in this manner than consumed during the operation of the reactor is called breeding. A fast reactor can be designed to serve as a good breeder reactor.

### **Uses of reactors**

- (1) Nuclear reactors are mostly aimed at power production, because of the large amount of energy evolved with fission.
- (2) Nuclear reactors are useful to produce radio-isotopes.

(3) Nuclear reactor acts as a source of neutrons, hence used in the scientific research.

***Nuclear power programme in India***

The atomic energy commission was established in 1948 with Dr. Homi J. Bhabha as its first chairman. The Department of Atomic Energy has constituted many research reactors and critical facilities of different designs and with varying power levels. Research reactors are powerful tools for carrying out basic and applied research in a number of disciplines. The research reactors in India include Apsara, Cirus, Dhruva and Purnima in Bhabha Atomic Research Centre (BARC) Trombay, Maharashtra, and Kamini at Indira Gandhi Centre for Atomic Research (IGCAR), Kalpakkam, Tamil Nadu. They support research work, that requires the use of neutrons and also to produce radio isotopes for use in research, medicine, agriculture, industry, food preservation, etc. One more research reactor at Kalpakkam, Fast Breeder Test Reactor (FBTR) is mainly used to test fuel and other materials used in the fast reactors and to develop sodium technology.

Nuclear Power Corporation of India Ltd. (NPCIL) is the public sector company which owns, constructs and operates nuclear power plants in India. NPCIL plans to put up a total installed nuclear power capacity of 20,000 MW by the year 2020.

India's nuclear power programme has fourteen reactors in operation. There are twelve pressurised heavy water reactors (PHWR) and two boiling water reactors (BWR) with a total power generation capacity of 2770 MW. The operating nuclear power reactors are given in the table 8.1

**Table 8.1 Operating nuclear power reactors (NOT FOR EXAMINATION)**

<b>Location</b>	<b>Type</b>	<b>Capacity</b>	<b>Number of units</b>
Tarapur, Maharashtra Kota, Rajasthan	BWR	160 MW	2
	PHWR	100 MW	1
		200 MW	1
		220 MW	2
Kalpakkam, Tamil Nadu	PHWR	170 MW	1
		220 MW	1
Narora, Uttarpradesh	PHWR	220 MW	2
Kakrapara, Gujarat	PHWR	220 MW	2
Kaiga, Karnataka	PHWR	220 MW	2

The nuclear power reactors under construction are given in the table 8.2

**Table 8.2 Nuclear power reactors under construction  
(NOT FOR EXAMINATION)**

Location	Type	Capacity	Number of units	Expected criticality date
Tarapur, Maharashtra (3 & 4)	PHWR	540 MW	2	Unit 3 - July 2006 Unit 4 - Dec. 2004
Kaiga, Karnataka (3 & 4)	PHWR	220 MW	2	Unit 3 - Dec. 2006 Unit 4 - June 2007
Rajasthan (5 & 6)	PHWR	220 MW	2	Unit 5 - May 2007 Unit 6 - Nov. 2007
Koodankulam, Tamil Nadu (1 & 2)	PWR	1000 MW	2	Unit 1 - 2007 Unit 2 - 2008
Kalpakkam, Tamil Nadu (3)	PFBR	500 MW	1	Unit 3 - 2010

### 8.10 Nuclear fusion

Nuclear fusion is a process in which two or more lighter nuclei combine to form a heavier nucleus. The mass of the product nucleus is always less than the sum of the masses of the individual lighter nuclei. The difference in mass is converted into energy. The fusion process can be carried out only at a extremely high temperature of the order of  $10^7$  K because, only at these very high temperatures the nuclei are able to overcome their mutual repulsion. Therefore before fusion, the lighter nuclei must have their temperature raised by several million degrees. The nuclear fusion reactions are known as thermo-nuclear reactions.

#### 8.10.1 Hydrogen bomb

The principle of nuclear fusion is used in hydrogen bomb. It is an explosive device to release a very large amount of energy by the fusion of light nuclei. The temperature required for the purpose of fusion is produced by fission reactions. The explosion of an atom bomb produces temperature of the order of 50 million degree celcius. A suitable assembly of deuteron and triton is arranged at the sight of the explosion of the atom bomb. Favourable temperature initiates the fusion of light nuclei in an uncontrolled manner. This releases enormous amount of heat energy.

The fusion reaction in hydrogen bomb is

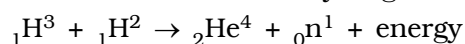

### 8.10.2 Stellar energy

Fusion is the source of stellar energy. The temperature of the interior of the sun is about  $1.4 \times 10^7$  K and the temperature of some stars is of the order  $10^8$  K. It has been estimated that the total energy radiated by sun is about  $3.8 \times 10^{26}$  joule per second. The origin of such a tremendous amount of energy is neither chemical nor gravitational. The fusion of protons into helium is supposed to release energy in sun and stars. All the elements like hydrogen and helium are in a highly ionised state called plasma at such a high temperature. The energy produced in fusion is responsible for the maintenance of high temperature of the sun and stars and also for the emission of energy in the form of heat and light.

Proton–proton cycle and carbon–nitrogen cycle are the two important types in which nuclear fusion takes place in sun and stars.

#### **Proton – Proton cycle**

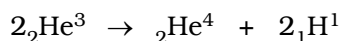
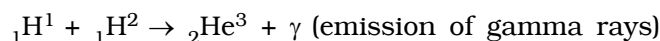

The reaction cycle is written as

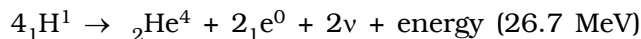

Thus four protons fuse together to form an alpha particle and two positrons with a release of large amount of energy.

#### **Carbon – Nitrogen Cycle**

The following cycle of reactions take place in carbon – nitrogen cycle in which carbon acts as a catalyst.

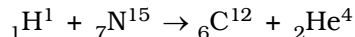
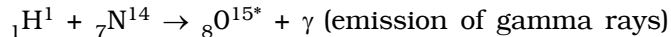
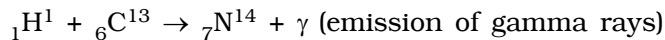
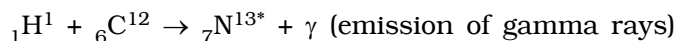

The overall reaction of the above cycle is given as

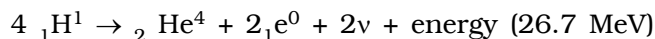

### 8.11 Cosmic Rays

The study of cosmic rays started with gold leaf electroscope experiment. It was found that if a properly insulated and charged gold leaf electroscope is left to itself, the charge leaks gradually, which happened in all the places on the land, mines and sea. Ionising radiation coming from the outer space is the reason for leakage of charges. The ionising radiation many times stronger than  $\gamma$ -rays entering the earth from all the directions from cosmic or interstellar space is known as cosmic rays. The name, cosmic rays was given by Millikan.

The cosmic rays can be broadly classified into primary and secondary cosmic rays. The primary cosmic rays are those coming from outer space and enter the outer boundary of the earth's atmosphere. The primary cosmic rays consist of 90% protons, 9% helium nuclei and remaining heavy nuclei. The energy of the primary cosmic rays is of the order  $10^8$  MeV.

The secondary cosmic rays are produced when primary cosmic rays interact with gases in the upper layers of the atmosphere. They are made up of particles like  $\alpha$ -particles, protons, electrons, positrons, mesons, photons, etc. in different proportions.

#### **Latitude effect**

The experiments to study the variation of cosmic ray intensity ( $I$ ) with geomagnetic latitude ( $\theta$ ) showed that the intensity is maximum at the poles ( $\theta = 90^\circ$ ), minimum at the equator ( $\theta = 0$ ) and constant between latitudes of  $42^\circ$  and  $90^\circ$ . The variation of cosmic ray intensity with geomagnetic latitude is known as latitude effect and is shown in Fig 8.11.

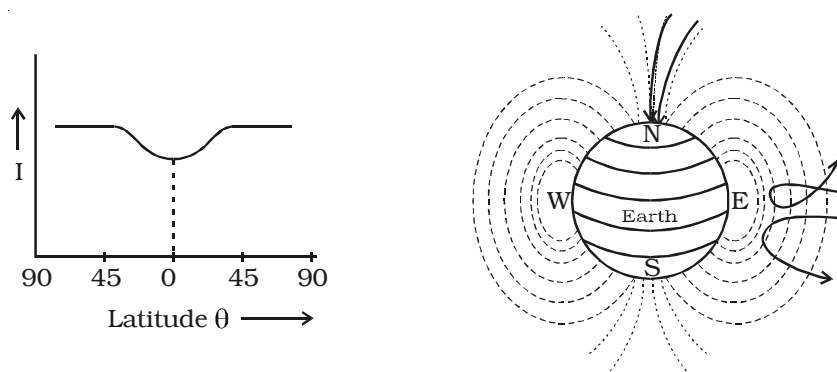

Fig 8.11 Latitude effect

The decrease in cosmic ray intensity at the earth's equator is explained to be due to the earth's magnetic field. The charged particles approaching the earth near the poles travel almost along the direction of the magnetic lines of force. They experience no force and easily reach the surface of the earth and hence maximum intensity at poles. But the charged particles that approach at the equator have to travel in a perpendicular direction to the field and are deflected away. Only particles with sufficient energy can reach the equator, while the slow particles are deflected back into cosmos and hence minimum intensity at the equator.

### **Altitude effect**

The study of variation of cosmic ray intensity ( $I$ ) with altitude ( $h$ ) is known as altitude effect, which is represented in Fig 8.12. It is seen that the intensity increases with altitude and reaches a maximum at a height of about 20 km. Above this height there is a fall in intensity. The experimental results are similar at different places of the earth.

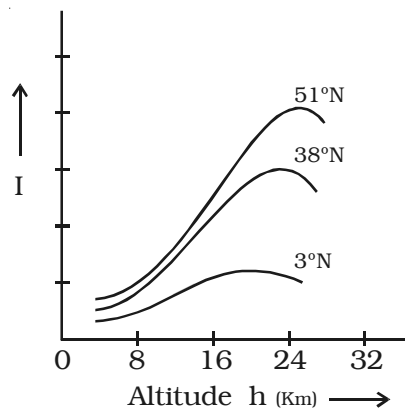

Fig 8.12 Altitude effect

### **Cosmic ray showers**

When a detecting device is used to study cosmic ray intensities, it is observed that the intensity rises momentarily to several times its normal value, which indicates sudden burst of radiation.

The cascade theory of cosmic ray shower shows that the shower production involves two processes, radiative collision and pair production (Fig. 8.13). An energetic electron or positron present in cosmic rays loses energy, when it collides with the nuclei of atoms in earth's atmosphere. This energy loss appears as high energy photon. This photon interacts with an atomic nucleus and produce an electron positron pair. The electron and positron, so produced have sufficient energies to produce more photons on interaction with nuclei, which are further capable of bringing about pair production. The result is the generation of a large number of photons, electrons and positrons having a common origin like a shower and hence it is known as cosmic ray

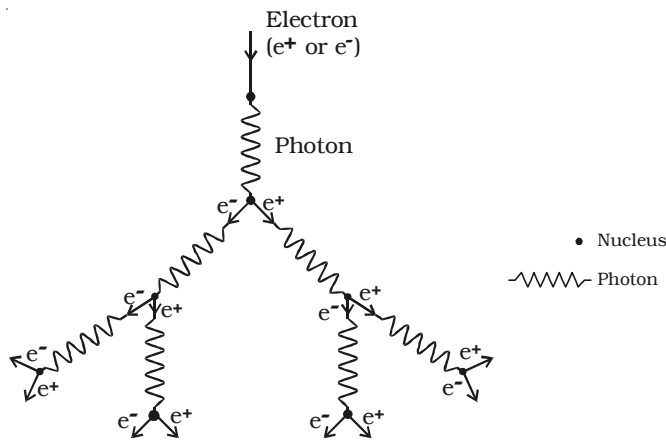

Fig 8.13 Cosmic ray shower

shower. The multiplication will continue until the initial energy becomes divided and the individual energy of the particles fall below the 'critical energy' when photon emission and pair production can no longer occur.

**Pair production and annihilation of matter**

The conversion of a photon into an electron–positron pair on its interaction with the strong electric field surrounding a nucleus is called pair production.

The converse of pair production in which an electron and positron combine to produce a photon is known as annihilation of matter.

**8.12 Elementary particles**

The study of the structure of atom reveals that the fundamental particles electron, proton and neutron are the building blocks of an atom. But the extensive studies on cosmic rays have revealed the existence of numerous new nuclear particles like mesons. These particles are classified into four major groups as photons, leptons mesons and baryons.

**Photon**

Photon is a quantum of radiation with no charge and no mass, but it is a carrier of energy. It travels with velocity of light.

**Lepton**

Leptons are lighter particles having mass equal to or less than about 207 times the mass of an electron except neutrino and antineutrino. This group contains particles such as electron, positron, neutrino, antineutrino, positive and negative muons. The electron and positron are the antiparticles. Neutrino and antineutrino are also

associated with  $\beta$ -ray emission. The neutrinos and antineutrinos are massless and chargeless particles, but carrier of energy and spin. Muons were discovered in cosmic ray studies.

### **Mesons**

Mesons are fundamental particles carrying a single unit of charge and possessing mass intermediate between electron and proton ( $m_e$  and  $m_p$ ). The name meson was given by Yukawa in 1935. The three types of mesons are (i)  $\pi$ -meson (pion) (ii) K-meson (kaon) and (iii)  $\eta$ -meson. The mesons are the interaction agents between nucleons. The rest mass of mesons vary between  $250 m_e$  and  $1000 m_e$ .

### **Baryons**

Baryons form the heavier particle group. Protons and neutrons are called nucleons and the rest of the heavier particles other than nucleons are known as hyperons. There are four types of hyperons which are lambda, sigma, xi and omega hyperons. Protons and neutrons are around 1836 times the mass of the electron, whereas the mass of the hyperons vary from  $2180 m_e$  and  $3275 m_e$ .

The classification of elementary particles is tabulated in Table 8.3.

**Table 8.3 Classification of elementary particles  
(NOT FOR EXAMINATION)**

<b>Group</b>	<b>Name</b>	<b>Symbol</b>	<b>Mass in terms of rest mass of electron (<math>m_e</math>)</b>
Photons	Photons	$\gamma$	0
Leptons	Neutrino	$\nu, \bar{\nu}$	0
	Electron	$e^\pm$	1
Mesons	Muon	$\mu^\pm$	207
	Pion	$\pi^\pm, \pi^0$	273
	Kaon	$K^\pm, K^0$	851
	Eta meson	$\eta^0$	1072
Baryons	Proton	$p^\pm$	1836
	Neutron	$n$	1840
	Lambda hyperon	$\lambda^0$	2180
	Sigma hyperon	$\Sigma^\pm, \Sigma^0$	2340
	Xi hyperon	$\Xi^0, \Xi^-$	2583
	Omega hyperon	$\Omega^-$	3272



### Solved Problems

8.1 Calculate the binding energy and binding energy per nucleon of  ${}_{26}\text{Fe}^{56}$  nucleus. Given,

$$\text{mass of } {}_{26}\text{Fe}^{56} \text{ nucleus} = 55.9349 \text{ amu}$$

$$\text{mass of 1 proton} = 1.007825 \text{ amu}$$

$$\text{mass of 1 neutron} = 1.008665 \text{ amu}$$

**Data :** Mass of  ${}_{26}\text{Fe}^{56}$  nucleus = 55.9349 amu

$$\text{Mass of 1 proton} = 1.007825 \text{ amu}$$

$$\text{Mass of 1 neutron} = 1.008665 \text{ amu}$$

$$\text{Number of protons } A = 26$$

$$\text{Number of neutrons } N = 30$$

$$\text{Binding energy and binding energy per nucleon} = ?$$

**Solution :** Mass of 26 Protons =  $26 \times 1.007825$

$$= 26.20345 \text{ amu}$$

$$\text{Mass of 30 neutrons} = 30 \times 1.008665$$

$$= 30.25995 \text{ amu}$$

$$\text{Total mass of the nucleons} = 26.20345 + 30.25995$$

$$= 56.46340 \text{ amu}$$

$$\text{Actual mass of the } {}_{26}\text{Fe}^{56} \text{ Nucleus} = 55.9349 \text{ amu}$$

$$\therefore \text{Mass defect} = 56.4634 - 55.9349$$

$$= 0.5285 \text{ amu}$$

$$\text{But 1 amu} = 931 \text{ MeV}$$

$$\text{Binding energy} = 0.5285 \times 931 = 492.0335 \text{ MeV}$$

$$\text{Binding energy per nucleon} = \frac{492.0335}{56} \text{ MeV}$$

$$= 8.786 \text{ MeV}$$

8.2 The binding energy per nucleon for  ${}_{6}\text{C}^{12}$  nucleus is 7.68 MeV and that for  ${}_{6}\text{C}^{13}$  is 7.47 MeV. Calculate the energy required to remove a neutron from  ${}_{6}\text{C}^{13}$  nucleus.

**Data :** Binding energy per nucleon of  ${}_{6}\text{C}^{13} = 7.47 \text{ MeV}$

Binding energy per nucleon of  ${}_6\text{C}^{12} = 7.68 \text{ MeV}$

Binding energy of neutron = ?

**Solution :** We can write the reaction as

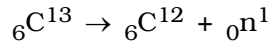

$$\begin{aligned} \text{Total binding energy of } {}_6\text{C}^{13} &= 7.47 \times 13 \\ &= 97.11 \text{ MeV} \end{aligned}$$

$$\begin{aligned} \text{Total binding energy of } {}_6\text{C}^{12} &= 7.68 \times 12 \\ &= 92.16 \text{ MeV} \end{aligned}$$

Total binding energy of the reactant

= Total binding energy of the product

$$\therefore 97.11 \text{ MeV} = 92.16 \text{ MeV} + \text{Binding energy of a neutron}$$

$$\begin{aligned} \therefore \text{Binding energy of a neutron} &= 97.11 - 92.16 \\ &= 4.95 \text{ MeV} \end{aligned}$$

- 8.3 Assuming that the energy released by the fission of a single  ${}_{92}\text{U}^{235}$  nucleus is 200 MeV, calculate the number of fissions per second required to produce 1 watt of power.

**Data :** Energy per fission = 200 MeV

Required power = 1 watt = 1 J/s

Number of fissions per second = ?

**Solution :**

Since the two energies are in different units, we must convert them into the same unit.

$$\therefore \text{Energy released per fission} = 200 \text{ MeV.}$$

$$= 200 \times 10^6 \text{ eV}$$

$$= 200 \times 10^6 \times 1.6 \times 10^{-19} \text{ J} \quad [\because 1\text{eV} = 1.6 \times 10^{-19} \text{ J}]$$

$$= 320 \times 10^{-13} \text{ joules}$$

Let N be the number of fissions per second, producing 1 W.

Energy per fission  $\times$  N = Total energy released per second.

$$\therefore 320 \times 10^{-13} \times N = 1 \text{ J/s.}$$

$$\begin{aligned}\therefore N &= \frac{1}{320 \times 10^{-13}} \\ &= 3.125 \times 10^{10} \text{ fissions}\end{aligned}$$

Number of fissions per second to produce the required power is  $3.125 \times 10^{10}$

- 8.4 Determine the amount of  $\text{Po}^{210}$  required to provide a source of  $\alpha$  particles of activity 5 milli curie. Given  $T_{1/2}$  of polonium is 138 days.

**Data :**  $T_{1/2}$  for polonium = 138 days

$$\frac{dN}{dt} = 5 \text{ milli curie} = 5 \times 3.7 \times 10^{10} \times 10^{-3} \text{ disintegrations per second}$$

Amount of polonium sample = ?

$$\begin{aligned}\text{Solution : } \lambda &= \frac{0.6931}{138} \text{ per day} \\ &= \frac{0.6931}{138 \times 24 \times 60 \times 60} \text{ per second}\end{aligned}$$

$$\begin{aligned}\text{The activity } \frac{dN}{dt} &= 5 \text{ milli curie} \\ &= 5 \times 10^{-3} \times 3.7 \times 10^{10} \text{ disintegration per second} \\ &= 5 \times 3.7 \times 10^7 \text{ disintegration per second}\end{aligned}$$

From law of disintegration,

$$\begin{aligned}\frac{dN}{dt} &= \lambda N \\ \therefore N &= \frac{dN}{dt} \cdot \frac{1}{\lambda} \\ &= \frac{5 \times 3.7 \times 10^7 \times 24 \times 60 \times 60 \times 138}{0.6931} \\ &= 3.1825 \times 10^{15} \text{ atoms}\end{aligned}$$

According to Avagadro's principle,  $6.023 \times 10^{23}$  atoms = 210 g of polonium

$$\therefore 3.1825 \times 10^{15} \text{ atoms} = \frac{210 \times 3.1825 \times 10^{15}}{6.023 \times 10^{23}} = 1.11 \times 10^{-6}$$

$\therefore$  Amount required is,  $1.11 \times 10^{-6}$  g

8.5 Calculate the time required for 60% of a sample of radon to undergo decay. Given  $T_{1/2}$  of radon = 3.8 days

**Data :** Half life of radon ( $T_{1/2}$ ) = 3.8 days

Amount of sample disintegrated = 60%

Time required = ?

**Solution :**  $\lambda = \frac{0.6931}{3.8}$  per day

Amount of sample disintegrated = 60%

Amount of sample present = 40%

Let  $N_0$  be the original amount of the sample present.

From law of disintegration,

$$N = N_0 e^{-\lambda t}$$

Substituting for  $N = 40\%$  of  $N_0$ ,

$$\frac{40}{100} N_0 = N_0 e^{-\lambda t}$$

$$\therefore e^{\lambda t} = \frac{10}{4}$$

$$\log_e 2.5 = \lambda \times t$$

$$\therefore t = \frac{3.8}{0.6931} \times \log_{10} 2.5 \times 2.3026 = 5.022 \text{ days}$$

8.6 Calculate the energy released in the reaction

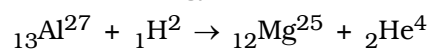

**Given :** Mass of  ${}_{13}\text{Al}^{27} = 26.981535$  amu

Mass of  ${}_1\text{H}^2 = 2.014102$  amu

Mass of  ${}_{12}\text{Mg}^{25} = 24.98584$  amu

Mass of  ${}_2\text{He}^4 = 4.002604$  amu

**Data** : Mass of  ${}_{13}\text{Al}^{27}$  = 26.981535 amu  
 Mass of  ${}_{1}\text{H}^2$  = 2.014102 amu  
 Mass of  ${}_{12}\text{Mg}^{25}$  = 24.98584 amu  
 Mass of  ${}_{2}\text{He}^4$  = 4.002604 amu  
 Energy released = ?

**Solution** : Mass of the reactants = 26.981535 + 2.014102  
 = 28.995637 amu  
 Mass of the products = 24.98584 + 4.002604  
 = 28.988444 amu

$\therefore$  Difference in mass in the reaction  
 = 28.995637 - 28.988444  
 = 0.007193 amu

$$1 \text{ amu} = 931 \text{ MeV}$$

$\therefore$  Energy released in the reaction = 0.007193  $\times$  931  
 = 6.697 MeV

8.7 Calculate the energy released when 1 kg of  ${}_{92}\text{U}^{235}$  undergoes nuclear fission. Assume, energy per fission is 200 MeV. Avagadro number =  $6.023 \times 10^{23}$ . Express your answer in kilowatt hour also.

**Data** : Energy produced per fission of  ${}_{92}\text{U}^{235}$  = 200 MeV  
 Amount of  ${}_{92}\text{U}^{235}$  = 1 kg  
 Avagadro number =  $6.023 \times 10^{23}$   
 Energy released = ?

**Solution** : Energy released in one fission = 200 MeV

According to Avagadro's hypothesis,

$$\text{Number of atoms in 235 g of uranium} = 6.023 \times 10^{23}$$

$\therefore$  Number of atoms in 1 kg (1000 gm) of Uranium

$$= \frac{6.023 \times 10^{26}}{235}$$

$\therefore$  Energy produced by 1 kg of uranium during fission,  $E = \frac{6.023 \times 10^{26}}{235} \times 200 \text{ MeV}$

$$\begin{aligned}
&= 5.126 \times 10^{26} \text{ MeV} \\
&= 5.126 \times 10^{26} \times 10^6 \text{ eV} \\
&= 5.126 \times 10^{32} \times 1.6 \times 10^{-19} \text{ J } [\because 1 \text{ eV} = 1.6 \times 10^{-19} \text{ J}]
\end{aligned}$$

1 kilowatt hour =  $3.6 \times 10^6$  joule

$$\begin{aligned}
\therefore E &= \frac{5.126 \times 10^{32} \times 1.6 \times 10^{-19}}{3.6 \times 10^6} \text{ kWh} \\
&= 2.2782 \times 10^7 \text{ kWh}
\end{aligned}$$

8.8 Thorium ( ${}_{90}\text{Th}^{228}$ ) emits an  $\alpha$ -particle to reduce to  ${}_{88}\text{Ra}^{224}$ . Calculate the kinetic energy of the  $\alpha$ -particle emitted in the following decay.

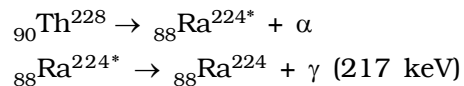

Given : mass of  ${}_{90}\text{Th}^{228}$  = 228.028726 amu

mass of  ${}_{88}\text{Ra}^{224}$  = 224.020196 amu

mass of  ${}_{2}\text{He}^4$  = 4.002604 amu

**Data :** mass of  ${}_{90}\text{Th}^{228}$  = 228.028726 amu

mass of  ${}_{88}\text{Ra}^{224}$  = 224.020196 amu

mass of  ${}_{2}\text{He}^4$  = 4.002604 amu

Energy of  $\gamma$ -ray = 217 keV

Energy of  $\alpha$ -particle = ?

**Solution :**

The  $\alpha$ -decay of thorium can be represented as in the figure.

$\therefore$  Mass of the products = 224.020196 + 4.002604

$$= 228.022800 \text{ amu}$$

$\therefore$  Mass defect = 228.028726 - 228.022800

$$= 0.005926 \text{ amu}$$

$$1 \text{ amu} = 931 \text{ MeV}$$

$\therefore$  Maximum energy of  $\alpha$ -particle

$$= 0.005926 \times 931$$

$$= 5.517 \text{ MeV}$$

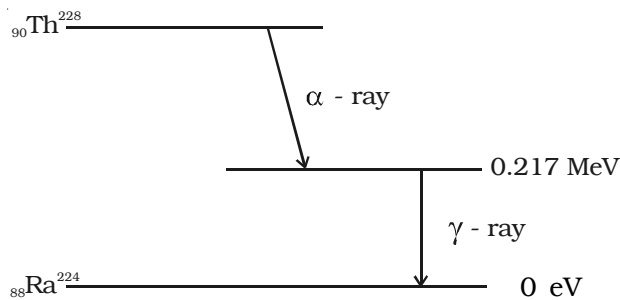

In this case energy of  $\alpha$  -particle emitted = maximum energy of  $\alpha$ -particle - Energy of  $\gamma$ -ray

$$= 5.517 - 0.217$$

$$= 5.300 \text{ MeV}$$

- 8.9 Calculate the mass of coal required to produce the same energy as that produced by the fission of 1 kg of  $\text{U}^{235}$ . Given ; heat of combustion of coal =  $33.6 \times 10^6 \text{ J/kg}$ , 1 ton = 1000 kg. Energy per fission of  $\text{U}^{235}$  = 200 MeV.  $1\text{eV} = 1.6 \times 10^{-19} \text{ J}$ . Avagadro number  $N = 6.023 \times 10^{23}$

**Data :** Energy per fission = 200 MeV;

$$1 \text{ eV} = 1.6 \times 10^{-19} \text{ J}$$

$$\text{Avagadro number } N = 6.023 \times 10^{23}$$

$$\text{Heat of combustion of coal} = 33.6 \times 10^6 \text{ J/kg}$$

$$\text{Mass of coal} = ?$$

**Solution :** Energy per fission of  $\text{U}^{235}$  = 200 MeV

$$= 200 \times 10^6 \text{ eV}$$

$$= 200 \times 10^6 \times 1.6 \times 10^{-19} \text{ J}$$

$$\text{Number of atoms in 235 g of } \text{U}^{235} = 6.023 \times 10^{23}$$

$$\therefore \text{Number of atoms in 1 kg (1000 g)} = \frac{6.023}{235} \times 10^{23} \times 1000$$

$$= \frac{6.023 \times 10^{26}}{235}$$

$\therefore$  Energy produced by the fission of 1 kg of  $\text{U}^{235}$

$$= \frac{6.023 \times 10^{26}}{235} \times 200 \times 10^6 \times 1.6 \times 10^{-19} \text{ J}$$

$$= 8.2016 \times 10^{13} \text{ J}$$

Heat of combustion of coal =  $33.6 \times 10^6$  J /kg.

Let M be the mass in kg of the coal required to produce equivalent energy produced by 1 kg of  $U^{235}$

$$\therefore 33.6 \times 10^6 \times M = 8.2016 \times 10^{13} \text{ J}$$

$$\begin{aligned}\therefore M &= \frac{8.2016 \times 10^{13}}{33.6 \times 10^6} \\ &= 0.2441 \times 10^7 \text{ Kg} \\ &= 2.441 \times 10^6 \text{ kg}\end{aligned}$$

$$1000 \text{ kg} = 1 \text{ ton}$$

$$\begin{aligned}\therefore 2.441 \times 10^6 \text{ kg} &= 2441 \times 10^3 \text{ kg} \\ &= 2441 \text{ ton}\end{aligned}$$

$\therefore$  2441 ton of coal is required to produce the same energy as that produced by fission of 1 kg of  $U^{235}$ .

- 8.10 A piece of bone from an archaeological site is found to give a count rate of 15 counts per minute. A similar sample of fresh bone gives a count rate of 19 counts per minute. Calculate the age of the specimen. Given :  $T_{1/2} = 5570$  years

**Data :** Count rate of fresh sample,  $N_0 = 19$  counts per minute

Count rate of bone  $N = 15$  counts per minute

$T_{1/2} = 5570$  years ; Age of the sample,  $t = ?$

**Solution :**  $N = N_0 e^{-\lambda t}$

$$\lambda = \frac{0.6931}{5570}$$

$$15 = 19 e^{-\lambda t} \quad (\text{or}) \quad e^{\lambda t} = \frac{19}{15}$$

$$\log e^{\frac{19}{15}} = \lambda t \quad (\text{or}) \quad t = \log e^{\frac{19}{15}} \times \frac{1}{\lambda}$$

$$t = \frac{5570}{0.6931} \times 2.3026 \times \log_{10} \frac{19}{15}$$

$$= \frac{5570}{0.6931} \times 2.3026 \times 0.1026$$

$$t = 1899 \text{ years}$$



### Self evaluation

*(The questions and problems given in this self evaluation are only samples. In the same way any question and problem could be framed from the text matter. Students must be prepared to answer any question and problem from the text matter, not only from the self evaluation.)*

- 8.1 The nuclear radius of  ${}_4\text{Be}^8$  nucleus is  
(a)  $1.3 \times 10^{-15}$  m (b)  $2.6 \times 10^{-15}$  m  
(c)  $1.3 \times 10^{-13}$  m (d)  $2.6 \times 10^{-13}$  m
- 8.2 The nuclei  ${}_{13}\text{Al}^{27}$  and  ${}_{14}\text{Si}^{28}$  are example of  
(a) isotopes (b) isobars  
(c) isotones (d) isomers
- 8.3 The mass defect of a certain nucleus is found to be 0.03 amu. Its binding energy is  
(a) 27.93 eV (b) 27.93 KeV  
(c) 27.93 MeV (d) 27.93 GeV
- 8.4 Nuclear fission can be explained by  
(a) shell model (b) liquid drop model  
(c) quark model (d) Bohr atom model
- 8.5 The nucleons in a nucleus are attracted by  
(a) gravitational force (b) electrostatic force  
(c) nuclear force (d) magnetic force
- 8.6 The ionisation power is maximum for  
(a) neutrons (b)  $\alpha$  - particles  
(c)  $\gamma$  - rays (d)  $\beta$  - particles
- 8.7 The half life period of a certain radioactive element with disintegration constant 0.0693 per day is  
(a) 10 days (b) 14 days  
(c) 140 days (d) 1.4 days
- 8.8 The radio-isotope used in agriculture is  
(a)  ${}_{15}\text{P}^{31}$  (b)  ${}_{15}\text{P}^{32}$   
(c)  ${}_{11}\text{Na}^{23}$  (d)  ${}_{11}\text{Na}^{24}$

- 8.9 The average energy released per fission is  
 (a) 200 eV (b) 200 MeV  
 (c) 200 meV (d) 200 GeV
- 8.10 The explosion of atom bomb is based on the principle of  
 (a) uncontrolled fission reaction (b) controlled fission reaction  
 (c) fusion reaction (d) thermonuclear reaction
- 8.11 Anaemia can be diagnosed by  
 (a)  $_{15}\text{P}^{31}$  (b)  $_{15}\text{P}^{32}$   
 (c)  $_{26}\text{Fe}^{59}$  (d)  $_{11}\text{Na}^{24}$
- 8.12 In the nuclear reaction  $_{80}\text{Hg}^{198} + X \rightarrow _{79}\text{Au}^{198} + _1\text{H}^1$ , X-stands for  
 (a) proton (b) electron  
 (c) neutron (d) deuteron
- 8.13 In  $\beta$  - decay  
 (a) atomic number decreases by one  
 (b) mass number decreases by one  
 (c) proton number remains the same  
 (d) neutron number decreases by one
- 8.14 Isotopes have  
 (a) same mass number but different atomic number  
 (b) same proton number and neutron number  
 (c) same proton number but different neutron number  
 (d) same neutron number but different proton number
- 8.15 The time taken by the radioactive element to reduce to  $1/e$  times is  
 (a) half life (b) mean life  
 (c) half life/2 (d) twice the mean life
- 8.16 The half life period of  $\text{N}^{13}$  is 10.1 minute. Its life time is  
 (a) 5.05 minutes (b) 20.2 minutes  
 (c)  $\frac{10.1}{0.6931}$  minutes (d) infinity

- 8.17 Positive rays of the same element produce two different traces in a Bainbridge mass spectrometer. The positive ions have
- same mass with different velocity
  - same mass with same velocity
  - different mass with same velocity
  - different mass with different velocity
- 8.18 The binding energy of  ${}_{26}\text{Fe}^{56}$  nucleus is
- 8.8 MeV
  - 88 MeV
  - 493 MeV
  - 41.3 MeV
- 8.19 The ratio of nuclear density to the density of mercury is about
- $1.3 \times 10^{10}$
  - 1.3
  - $1.3 \times 10^{13}$
  - $1.3 \times 10^4$
- 8.20 With example explain the classification of the nuclei in terms of its proton number and neutron number.
- 8.21 Explain mass defect and binding energy.
- 8.22 Calculate the energy equivalence of 1 atomic mass unit.
- 8.23 Show that nuclear density is almost a constant for all the nuclei.
- 8.24 Explain the variation of binding energy with mass number by a graph and discuss its features.
- 8.25 Discuss the principle and action of a Bainbridge mass spectrometer to determine the isotopic masses.
- 8.26 Explain the different characteristics of nuclear forces.
- 8.27 Define radioactivity.
- 8.28 Explain the Soddy-Fajan's radioactive displacement law.
- 8.29 Obtain an expression to deduce the amount of the radioactive substance present at any moment.
- 8.30 Obtain the relation between half-life period and decay constant.
- 8.31 Define curie.
- 8.32 What do you mean by artificial radioactivity?
- 8.33 What are the applications of radio-isotopes?

- 8.34 Explain the construction and working of a Geiger–Muller Counter.
- 8.35 How do you classify the neutrons in terms of its kinetic energy?
- 8.36 What is artificial transmutation?
- 8.37 Explain how liquid drop model of the nucleus can account for nuclear fission.
- 8.38 With a neat sketch, explain the working of a nuclear reactor.
- 8.39 What is meant by breeder reactor?
- 8.40 What are thermonuclear reactions?
- 8.41 Explain how carbon–nitrogen cycle can account for the production of stellar energy.
- 8.42 What are cosmic rays?
- 8.43 Explain the latitude effect of cosmic rays.
- 8.44 Explain how the intensity of the cosmic rays changes with altitude.
- 8.45 Explain how a cosmic ray shower is formed.
- 8.46 How do you classify the elementary particles into four groups?

**Problems :**

- 8.47 The half-life of  ${}_{84}\text{Po}^{218}$  is 3 minute. What percentage of the sample has decayed in 15 minutes?
- 8.48 Calculate the radius of  ${}_{13}\text{Al}^{27}$  nucleus.
- 8.49 Find the energy released when two  ${}_{1}\text{H}^2$  nuclei fuse together to form a single  ${}_{2}\text{He}^4$  nucleus. Given, the binding energy per nucleon of  ${}_{1}\text{H}^2$  and  ${}_{2}\text{He}^4$  are 1.1 MeV and 7.0 MeV respectively.
- 8.50 Calculate the binding energy and binding energy per nucleon of  ${}_{20}\text{Ca}^{40}$  nucleus. Given, mass of 1 proton = 1.007825 amu ; mass of 1 neutron = 1.008665 amu ; mass of  ${}_{20}\text{Ca}^{40}$  nucleus = 39.96259 amu
- 8.51 Calculate the energy released in the following reaction.
- $${}_{3}\text{Li}^6 + {}_0\text{n}^1 \rightarrow {}_{2}\text{He}^4 + {}_{1}\text{H}^3$$
- Given mass of  ${}_{3}\text{Li}^6$  nucleus = 6.015126 amu  
 Mass of  ${}_{1}\text{H}^3$  nucleus = 3.016049 amu  
 Mass of  ${}_{2}\text{He}^4$  nucleus = 4.002604 amu  
 Mass of  ${}_0\text{n}^1$  = 1.008665 amu
- 8.52 Tritium has a half life of 12.5 years. What fraction of the sample of

will be left over after 25 years?

- 8.53 Show that the mass of radium ( ${}_{88}\text{Ra}^{226}$ ) with an activity of 1 curie is almost a gram. Given  $T_{1/2} = 1600$  years;  
1 curie =  $3.7 \times 10^{10}$  disintegrations per second.
- 8.54 The disintegration constant  $\lambda$  of a radioactive element is 0.00231 per day. Calculate its half life and mean life.
- 8.55 A reactor is developing energy at the rate of 32 MW. Calculate the required number of fissions per second of  ${}_{92}\text{U}^{235}$ . Assume that energy per fission is 200 MeV.
- 8.56 A carbon specimen found in a cave contained a fraction of 1/8 of  $\text{C}^{14}$  to that present in a living system. Calculate the approximate age of the specimen. Given  $T_{1/2}$  for  ${}_{6}\text{C}^{14} = 5560$  years.
- 8.57 The radioactive isotope  ${}_{84}\text{Po}^{214}$  undergoes a successive disintegration of two  $\alpha$ -decays and two  $\beta$ -decays. Find the atomic number and mass number of the resulting isotope.
- 8.58 The half life of radon is 3.8 days. Calculate its mean life
- 8.59 If 50% of a radioactive sample decays in 5 days, how much of the original sample will be left over after 20 days?
- 8.60 The isotope  ${}_{92}\text{U}^{238}$  successively undergoes three  $\alpha$ -decays and two  $\beta$ -decays. What is the resulting isotope?
- 8.61 Singly ionized magnesium atoms enter into the velocity selector of a Bainbridge mass spectrograph having electric and magnetic fields 30 kV/m and 0.1 tesla respectively. Calculate the radii of the path followed by the three isotopes of mass numbers 24, 25 and 26 when the deflecting magnetic field is 0.5 tesla. Mass of a nucleon =  $1.67 \times 10^{-27}$  kg ; Charge of the ion,  $e = 1.6 \times 10^{-19}$  C.

**Answers**

- |                 |                 |                 |                 |
|-----------------|-----------------|-----------------|-----------------|
| <b>8.1</b> (b)  | <b>8.2</b> (c)  | <b>8.3</b> (c)  | <b>8.4</b> (b)  |
| <b>8.5</b> (c)  | <b>8.6</b> (b)  | <b>8.7</b> (a)  | <b>8.8</b> (b)  |
| <b>8.9</b> (b)  | <b>8.10</b> (a) | <b>8.11</b> (c) | <b>8.12</b> (c) |
| <b>8.13</b> (d) | <b>8.14</b> (c) | <b>8.15</b> (b) | <b>8.16</b> (d) |
| <b>8.17</b> (c) | <b>8.18</b> (c) | <b>8.19</b> (c) |                 |

8.47 96.875 %

8.48  $3.9 \times 10^{-15} \text{ m}$

8.49 23.6 MeV

8.50 341.8725 MeV; 8.5468 MeV

8.51 4.783 MeV

8.52 1/4

8.53 1.0107 g

8.54  $T_{1/2} = 300 \text{ days}; \tau = 432.9 \text{ days}$

8.55  $1 \times 10^{18} \text{ fissions per second}$

8.56 16681 year

8.57 Atomic number 82 and mass number 206

8.58 5.482 days

8.59 6.25%

8.60  ${}_{88}\text{Ra}^{226}$

8.61  $R_1 = 0.1503 \text{ m}; R_2 = 0.1565 \text{ m}; R_3 = 0.1628 \text{ m}.$

## **9. Semiconductor Devices and their Applications**

In years before the second world war, vacuum tubes were used in the process of electrical signal generation, amplification and transmission. After the invention of transistor in 1944 and subsequent improvement of the transistor and other solid state electronic devices, vacuum tubes were replaced by these solid state devices in many fields of applications. A solid state electronic device mainly consists of a semiconducting material. Some semiconductor devices and their applications are dealt in this chapter.

### **9.1 Semiconductors**

It has been observed that certain materials like germanium, silicon etc. have resistivity between good conductors like copper and insulators like glass. These materials are known as semiconductors. A material which has resistivity between conductors and insulators is known as semiconductor. The resistivity of a semiconductor lie approximately between  $10^{-2}$  and  $10^4 \Omega \text{ m}$  at room temperature. The resistance of a semiconductor decreases with increase in temperature over a particular temperature range. This behaviour is contrary to that of a metallic conductor for which the resistance increases with increase in temperature.

The elements that are classified as semiconductors are Si, Ge, In, etc. Germanium and silicon are most widely used as semiconductors.

#### **9.1.1 Energy band in solids**

In the case of a single isolated atom, there are various discrete energy levels. In solids, the atoms are arranged in a systematic space lattice and each atom is influenced by neighbouring atoms. The closeness of atoms results in the intermixing of electrons of neighbouring atoms. Due to this, number of permissible energy levels increases. Hence in the case of a solid, instead of a single energy level

associated with single atom, there will be bands of energy levels. A set of such closely packed energy levels is called an energy band. The bands of energy levels are referred to the entire solid as a whole and not to the single atom.

The concept of energy bands can be understood from Fig 9.1a and Fig 9.1b. The energy levels of a single isolated atom of silicon are shown in Fig 9.1a. Each silicon atom has 14 electrons, two of which

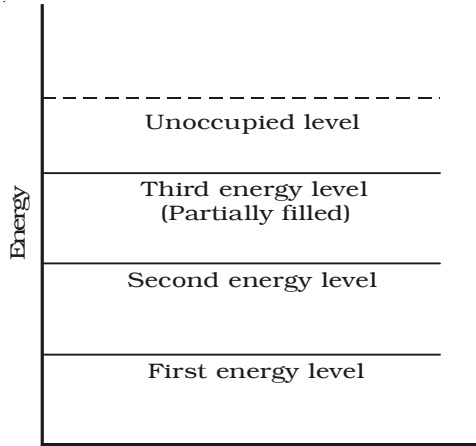

Fig 9.1a Energy levels of a single isolated atom

occupy K shell, 8 occupy the L shell and 4 occupy the M shell. The electrons in the M shell are distributed as 2 electrons in the subshell 3s and 2 electrons in the subshell 3p. This subshell 3p is partially

filled because it can accommodate a total of 6 electrons. The completely filled levels are known as core levels and the electrons filling these levels are called core electrons. The electrons in the outermost level are called valence electrons. The partially filled outermost level is valence level and the permitted levels which are vacant are known as conduction levels.

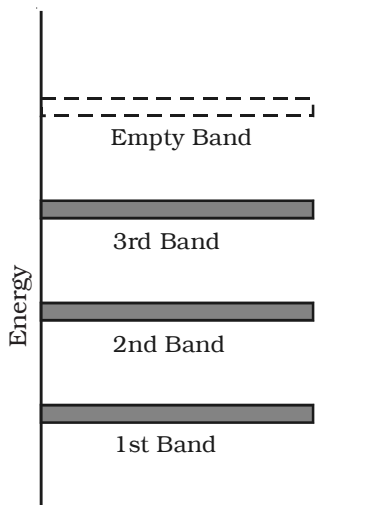

Fig 9.1b Energy bands in a solid

second energy band and so on as shown in Fig 9.1b.

In a solid, there are large number of atoms, which are very close to each other. The energy of s or p level is of the order of eV, therefore the levels are very closely spaced. The first orbit electrons form a band called first energy band. Similarly second orbit electrons form



### 9.1.2 Valence band, conduction band and forbidden energy gap

The atoms of a solid are arranged in a regular repeated geometric pattern and the electrons

of the atom revolve around the nucleus in certain permitted energy levels. The electrons in the inner shells are strongly bound to the nucleus. A band which is occupied by the valence electrons or a band having highest energy is defined as

valence band (Fig 9.2). The valence band may be partially or completely filled. This band can never be empty.

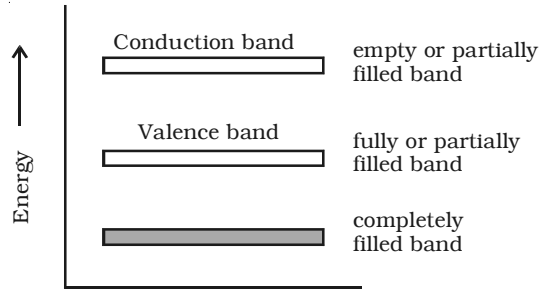

Fig 9.2 Valence band and conduction band

In some materials, the valence electrons are loosely attached to the nucleus. Even at room temperature, some of the valence electrons can leave the valence band. These are called as free electrons. They are responsible for conduction of current in a conductor and are henceforth called as conduction electrons. The band occupied by these electrons is called conduction band. This band may be an empty band or partially filled band.

The separation between valence band and conduction band is known as forbidden energy gap. If an electron is to be transferred from valence band to conduction band, external energy is required, which is equal to the forbidden energy gap.

### 9.1.3 Insulators, semiconductors and conductors

#### Insulators

In an insulator, the forbidden energy gap is very large (Fig 9.3a). In general, the forbidden energy gap is more than 3eV and almost no electrons are available for conduction. Therefore, a very large amount of energy must be supplied to a valence electron to enable it to move to the conduction band. In the case of materials like glass, the valence band is completely filled at 0 K. The energy gap between valence band and conduction band is of the order of 10 eV. Even in the presence of high electric field, the electrons cannot move from

valence band to conduction band. If the electron is supplied with high energy, it can jump across the forbidden gap. When the temperature is increased, some electrons will move to the conduction band. This is the reason, why certain materials, which are insulators at room temperature become conductors at high temperature. The resistivity of insulator approximately lies between  $10^{11}$  and  $10^{16} \Omega \text{ m}$ .

### **Semiconductors**

In semiconductors (Fig 9.3b), the forbidden gap is very small. Germanium and silicon are the best examples of semiconductors. The forbidden gap energy is of the order of 0.7eV for Ge and 1.1eV for Si. There are no electrons in the conduction band. The valence band is completely filled at 0 K. With a small amount of energy that is supplied, the electrons can easily jump from the valence band to the conduction band. For example, if the temperature is raised, the forbidden gap is decreased and some electrons are liberated into the conduction band. The conductivity of a semiconductor is of the order of  $10^2 \text{ mho m}^{-1}$ .

### **Conductors**

In conductors, there is no forbidden gap available, the valence and conduction band overlap each other (Fig 9.3c). The electrons from valence band freely enter into the conduction band. Due to the overlapping of the valence and conduction bands, a very low potential difference can cause the continuous flow of current.

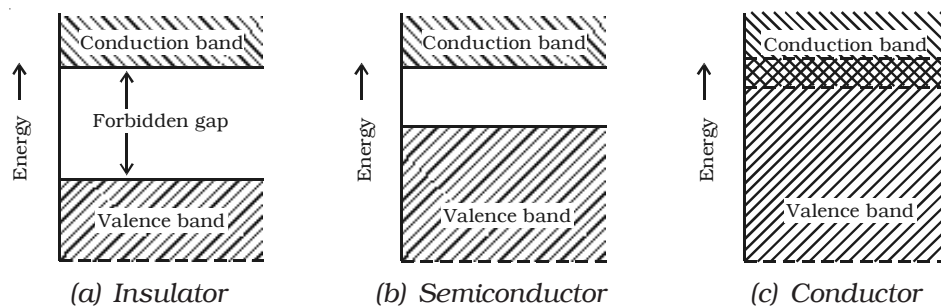

*Fig 9.3 Energy band of solids*

#### **9.1.4 Electrons and holes in semiconductors**

Fig 9.3b shows the energy band diagram of an intrinsic semiconductor (pure semiconductor). Fig 9.4a and Fig 9.4b represent charge carriers at absolute zero temperature and at room temperature respectively.

The electrons in an intrinsic semiconductor, which move in to the conduction band at high temperatures are called as intrinsic carriers. In the valence band, a vacancy is created at the place where the electron was present, before it had moved in to the conduction band. This vacancy is called hole. Fig 9.4c helps in understanding the creation of a hole. Consider the case of pure germanium crystal. It has four electrons in its outer or valence orbit. These electrons are known as valence electrons. When two atoms of germanium are brought close to each other, a covalent bond is formed between the atoms. If some additional energy is received, one of the electrons contributing to a covalent bond breaks and it is free to move in the crystal lattice.

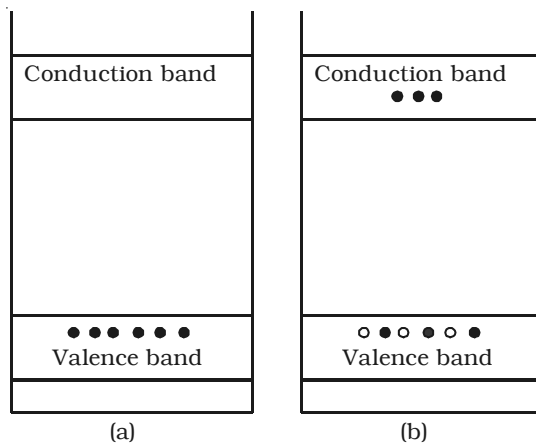

Fig 9.4a&b Electrons and holes in semiconductors

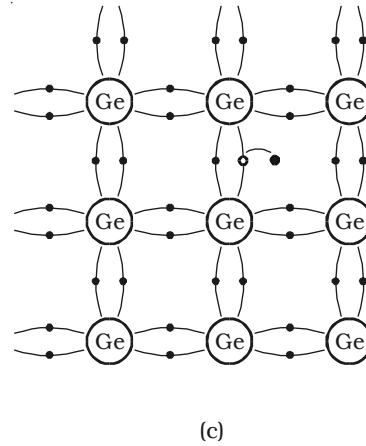

Fig 9.4c Formation of a hole

While coming out of the bond, a hole is said to be created at its place, which is usually represented by a open circle. An electron from the neighbouring atom can break the covalent bond and can occupy this hole, creating a hole at another place. Since an electron has a unit negative charge, the hole is associated with a unit positive charge. The importance of hole is that, it may serve as a carrier of electricity in the same manner as the free electron, but in the opposite direction.

### 9.1.5 Intrinsic semiconductor

A semiconductor which is pure and contains no impurity is known as an intrinsic semiconductor. In an intrinsic semiconductor, the number of free electrons and holes are equal. Common examples of intrinsic semiconductors are pure germanium and silicon.

The forbidden energy gap is so small that even at ordinary room temperature, there are many electrons which possess sufficient energy to cross the forbidden energy gap and enter into the conduction band. Schematic band diagram of an intrinsic semiconductor at room temperature is represented in Fig 9.5.

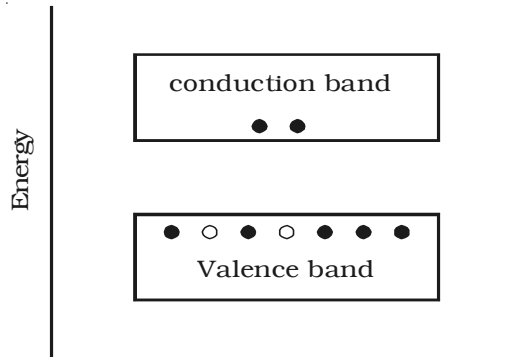

Fig 9.5 Energy band diagram of an intrinsic semiconductor

### 9.1.6 Doping a semiconductor

Electrons and holes can be generated in a semiconductor crystal with heat energy or light energy. But in these cases, the conductivity remains very low. The efficient and convenient method of generating free electrons and holes is to add very small amount of selected impurity inside the crystal. The impurity to be added is of the order of 100 ppm (parts per million). The process of addition of a very small amount of impurity into an intrinsic semiconductor is called doping. The impurity atoms are called dopants. The semiconductor containing impurity atoms is known as impure or doped or extrinsic semiconductor.

There are three different methods of doping a semiconductor.

(i) The impurity atoms are added to the semiconductor in its molten state.

(ii) The pure semiconductor is bombarded by ions of impurity atoms.

(iii) When the semiconductor crystal containing the impurity atoms is heated, the impurity atoms diffuse into the hot crystal.

Usually, the doping material is either pentavalent atoms (bismuth, antimony, phosphorous, arsenic which have five valence electrons) or trivalent atoms (aluminium, gallium, indium, boron which have three valence electrons). The pentavalent doping atom is known as donor atom, since it donates one electron to the conduction band of pure semiconductor. The trivalent atom is called an acceptor atom, because it accepts one electron from the pure semiconductor atom.

### 9.1.7 Extrinsic semiconductor

An extrinsic semiconductor is one in which an impurity with a valency higher or lower than the valency of the pure semiconductor is added, so as to increase the electrical conductivity of the semiconductor.

Depending upon the type of impurity atoms added, an extrinsic semiconductor can be classified as N-type or P-type.

#### (a) N-type semiconductor

When a small amount of pentavalent impurity such as arsenic is added to a pure germanium semiconductor crystal, the resulting crystal is called N-type semiconductor.

Fig 9.6a shows the crystal structure obtained when pentavalent arsenic impurity is added with pure germanium crystal. The four valence electrons of arsenic atom form covalent bonds with electrons of neighbouring four germanium atoms. The fifth electron of arsenic atom is loosely bound. This electron can move about almost as freely as an electron in a conductor and hence it will be the carrier of current. In the energy band picture, the energy state corresponding to the fifth valence electron is in the forbidden gap and lies slightly below the conduction band (Fig 9.6b). This level is known as the donor level.

When the fifth valence electron is transferred to the conduction band, the arsenic atom becomes positively charged immobile ion. Each impurity atom donates one free electron to the semiconductor. These impurity atoms are called donors.

In N-type semiconductor material, the number of electrons increases, compared to the available number of charge carriers in the intrinsic semiconductor. This is because, the available larger number of

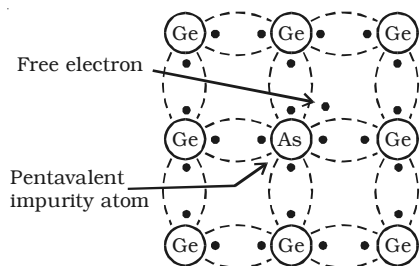

Fig 9.6a N-type semiconductor

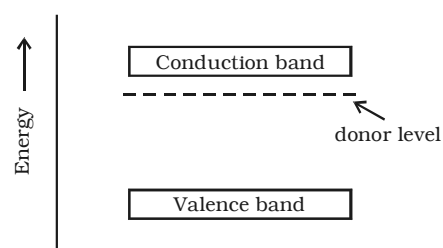

Fig 9.6b Energy band diagram of N-type semiconductor

electrons increases the rate of recombination of electrons with holes. Hence, in N-type semiconductor, free electrons are the majority charge carriers and holes are the minority charge carriers.

**(b) P-type semiconductor**

When a small amount of trivalent impurity (such as indium, boron or gallium) is added to a pure semiconductor crystal, the resulting semiconductor crystal is called P-type semiconductor.

Fig 9.7a shows the crystal structure obtained, when trivalent boron impurity is added with pure germanium crystal. The three valence electrons of the boron atom form covalent bonds with valence electrons of three neighbourhood germanium atoms. In the fourth covalent bond, only one valence electron is available from germanium atom and there is deficiency of one electron which is called as a hole. Hence for each boron atom added, one hole is created. Since the holes can accept electrons from neighbourhood, the impurity is called acceptor. The hole, may be filled by the electron from a neighbouring atom, creating a hole in that position from where the electron moves. This process continues and the hole moves about in a random manner due to thermal effects. Since the hole is associated with a positive charge moving from one position to another, this is called as P-type semiconductor. In the P-type semiconductor, the acceptor impurity produces an energy level just above the valence band. (Fig 9.7b). Since, the energy difference between acceptor energy level and the valence band is much smaller, electrons from the valence band can easily jump into the acceptor level by thermal agitation.

In P-type semiconductors, holes are the majority charge carriers and free electrons are the minority charge carriers.

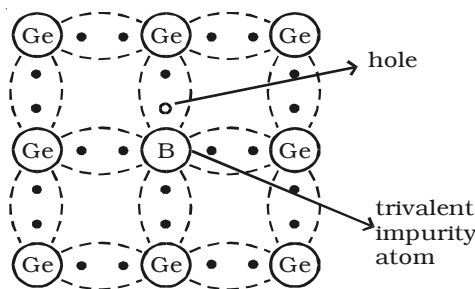

Fig 9.7a P-type semiconductor

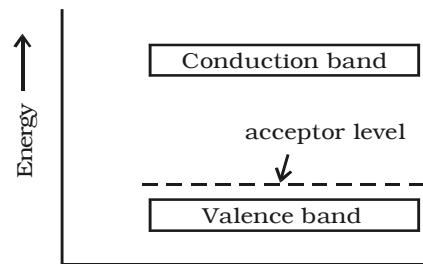

Fig 9.7b Energy band diagram of a P-type semiconductor

## 9.2 PN Junction diode

If one side of a single crystal of pure semiconductor (Ge or Si) is doped with acceptor impurity atoms and the other side is doped with donor impurity atoms, a PN junction is formed as shown in Fig 9.8. P region has a high concentration of holes and N region contains a large number of electrons.

As soon as the junction is formed, free electrons and holes cross through the junction by the process of diffusion. During this process, the electrons crossing the junction from N-region into the P region, recombine with holes in the P-region very close to the junction. Similarly holes crossing the junction from the P-region into the N-region, recombine

with electrons in the N-region very close to the junction. Thus a region is formed, which does not have any mobile charges very close to the junction. This region is called depletion

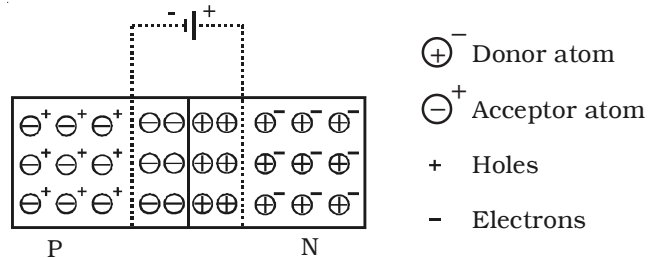

Fig 9.8 P N Junction diode

region. In this region, on the left side of the junction, the acceptor atoms become negative ions and on the right side of the junction, the donor atoms become positive ions (Fig 9.8).

An electric field is set up, between the donor and acceptor ions in the depletion region. The potential at the N-side is higher than the potential at P-side. Therefore electrons in the N-side are prevented to go to the lower potential of P-side. Similarly, holes in the P-side find themselves at a lower potential and are prevented to cross to the N-side. Thus, there is a barrier at the junction which opposes the movement of the majority charge carriers. The difference of potential from one side of the barrier to the other side is called potential barrier. The potential barrier is approximately 0.7V for a silicon PN junction and 0.3V for a germanium PN junction. The distance from one side of the barrier to the other side is called the width of the barrier, which depends upon the nature of the material.

**9.2.1 Forward biased PN junction diode**

When the positive terminal of the battery is connected to P-side and negative terminal to the N-side, so that the potential difference acts in opposite direction to the barrier potential, then the PN junction diode is said to be forward biased.

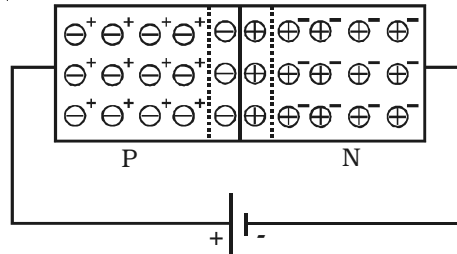

*Fig 9.9 Forward biased PN junction diode*

When the PN junction is forward biased (Fig 9.9), the applied positive potential repels the holes in the P-region, and the applied negative potential repels the electrons in the N-region, so the charges move towards the junction. If the applied potential difference is more than the potential barrier, some holes and free electrons enter the depletion region.

Hence, the potential barrier as well as the width of the depletion region are reduced. The positive donor ions and negative acceptor ions within the depletion region regain electrons and holes respectively. As a result of this, the depletion region disappears and the potential barrier also disappears. Hence, under the action of the forward potential difference, the majority charge carriers flow across the junction in opposite direction and constitute current flow in the forward direction.

**9.2.2 Reverse biased PN junction diode**

When the positive terminal of the battery is connected to the N-side and negative terminal to the P-side, so that the applied potential difference is in the same direction as that of barrier potential, the junction is said to be reverse biased.

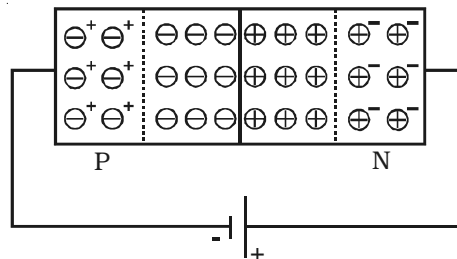

*Fig 9.10 Reverse biased PN junction diode.*

When the PN junction is reverse biased (Fig 9.10), electrons in the N region and holes in the P-region are attracted away from the junction.



Because of this, the number of negative ions in the P-region and positive ions in the N-region increases. Hence the depletion region becomes wider and the potential barrier is increased.

Since the depletion region does not contain majority charge carriers, it acts like an insulator. Therefore, no current should flow in the external circuit. But, in practice, a very small current of the order of few microamperes flows in the reverse direction. This is due to the minority carriers flowing in the opposite direction. This reverse current is small, because the number of minority carriers in both regions is very small. Since the major source of minority carriers is, thermally broken covalent bonds, the reverse current mainly depends on the junction temperature.

### 9.2.3 Symbol for a semiconductor diode

The diode symbol is shown in Fig 9.11. The P-type and N-type regions are referred to as P-end and N-end respectively. The arrow on the diode points the direction of conventional current.

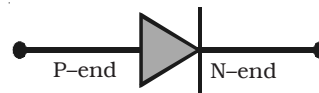
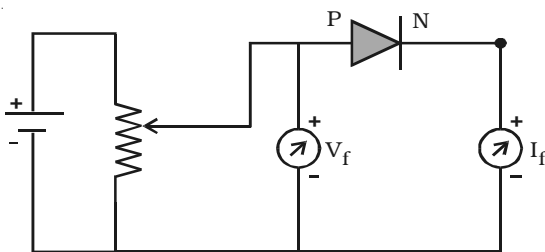
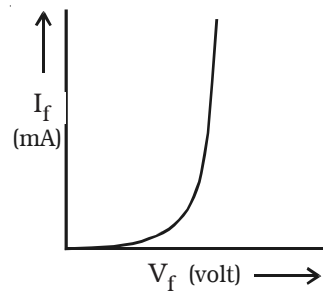

Fig 9.11 Circuit symbol for a semiconductor diode

### 9.2.4 Forward bias characteristics



(a) Diode circuit-Forward bias



(b) Forward characteristics

Fig 9.12 Forward bias characteristics of a diode

The circuit for the study of forward bias characteristics of PN junction diode is shown in Fig 9.12a. The voltage between P-end and N-end is increased from zero in suitable equal steps and the corresponding currents are noted down. Fig 9.12b shows the forward bias characteristic curve of the diode. Voltage is the independent variable. Therefore, it is plotted along X-axis. Since, current is the dependent variable, it is plotted against Y-axis. From the

characteristic curve, the following conclusions can be made. (i) The forward characteristic is not a straight line. Hence the ratio  $V/I$  is not a constant (i.e) the diode does not obey Ohm's law. This implies that the semiconductor diode is a non-linear conductor of electricity. (ii) It can be seen from the characteristic curve that initially, the current is very small. This is because, the diode will start conducting, only when the external voltage overcomes the barrier potential (0.7V for silicon diode). As the voltage is increased to 0.7 V, large number of free electrons and holes start crossing the junction. Above 0.7V, the current increases rapidly. The voltage at which the current starts to increase rapidly is known as cut-in voltage or knee voltage of the diode.

### 9.2.5 Reverse bias characteristics

The circuit for the study of reverse bias characteristics of PN junction diode is shown in Fig 9.13a. The voltage is increased from zero in suitable steps. For each voltage, the corresponding current readings are noted down. Fig 9.13b shows the reverse bias characteristic curve of the diode. From the characteristic curve, it can be concluded that, as voltage is increased from zero, reverse current (in the order of microamperes) increases and reaches the maximum value at a small value of the reverse voltage. When the voltage is further increased, the current is almost independent of the reverse voltage upto a certain critical value. This reverse current is known as the reverse saturation current or leakage current. This current is due to the minority charge carriers, which depends on junction temperature.

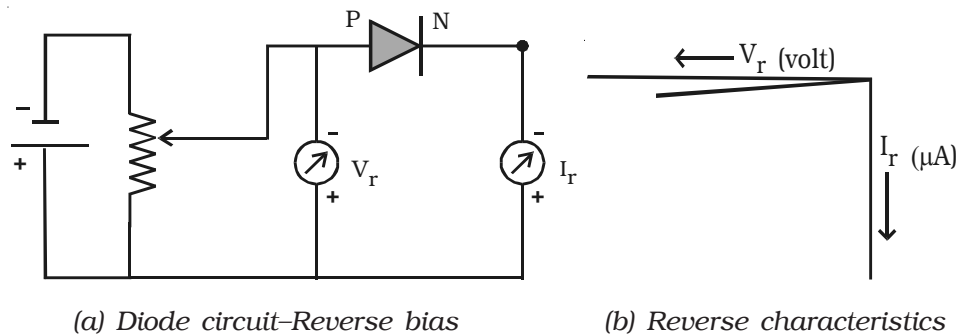

Fig 9.13 Reverse bias characteristics of a diode

### 9.3 PN junction diode as rectifier

The process in which alternating voltage or alternating current is converted into direct voltage or direct current is known as rectification. The device used for this process is called as rectifier. The junction diode has the property of offering low resistance and allowing current to flow through it, in the forward biased condition. This property is used in the process of rectification.

#### 9.3.1 Half wave rectifier

A circuit which rectifies half of the a.c wave is called half wave rectifier.

Fig 9.14 shows the circuit for half wave rectification. The a.c. voltage ( $V_s$ ) to be rectified is

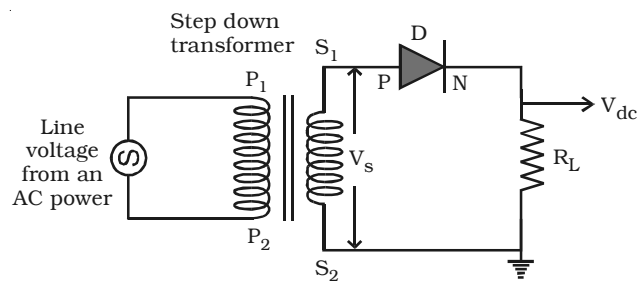

Fig 9.14 Half wave rectifier

obtained across the secondary ends  $S_1$   $S_2$  of the transformer. The P-end of the diode D is connected to  $S_1$  of the secondary coil of the transformer. The N-end of the diode is connected to the other end  $S_2$  of the secondary coil of the transformer, through a load resistance  $R_L$ . The rectified output voltage  $V_{dc}$  appears across the load resistance  $R_L$ .

During the positive half cycle of the input a.c. voltage  $V_s$ ,  $S_1$  will be positive and the diode is forward biased and hence it conducts.

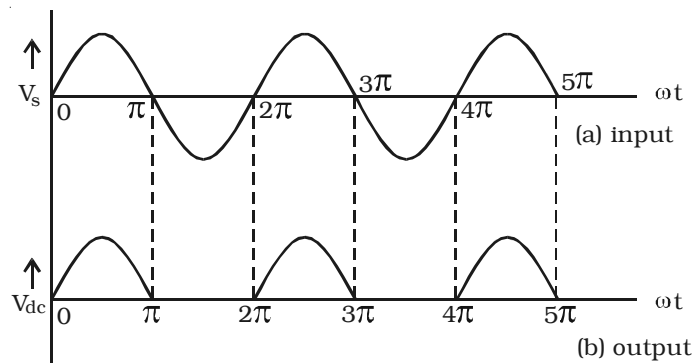

Fig 9.15 Half wave rectifier signals

Therefore, current flows through the circuit and there is a voltage drop across  $R_L$ . This gives the output voltage as shown in Fig 9.15.

During the negative half cycle of the input a.c. voltage ( $V_s$ ),  $S_1$  will be negative and the diode  $D$  is reverse biased. Hence the diode does not conduct. No current flows through the circuit and the voltage drop across  $R_L$  will be zero. Hence no output voltage is obtained. Thus corresponding to an alternating input signal, unidirectional pulsating output is obtained.

The ratio of d.c. power output to the a.c. power input is known as rectifier efficiency. The efficiency of half wave rectifier is approximately 40.6%

### 9.3.2 Bridge rectifier

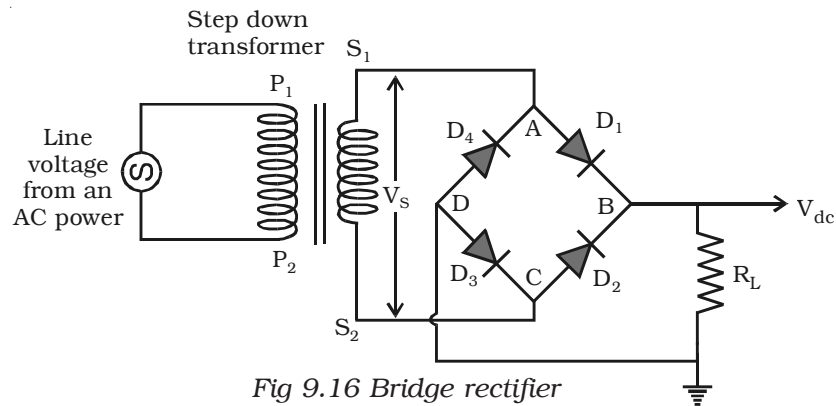

Fig 9.16 Bridge rectifier

A bridge rectifier is shown in Fig 9.16. There are four diodes  $D_1$ ,  $D_2$ ,  $D_3$  and  $D_4$  used in the circuit, which are connected to form a network. The input ends A and C of the network are connected to the secondary ends  $S_1$  and  $S_2$  of the transformer. The output ends B and D are connected to the load resistance  $R_L$ .

During positive input half cycle of the a.c. voltage, the point A is positive with respect to C. The diodes  $D_1$  and  $D_3$  are forward biased and conduct, whereas the diodes  $D_2$  and  $D_4$  are reverse biased and do not conduct. Hence current flows along  $S_1ABDCS_2$  through  $R_L$ . During negative half cycle, the point C is positive with respect to A. The diodes  $D_2$  and  $D_4$  are forward biased and conduct, whereas the diodes  $D_1$  and  $D_3$  are reverse biased and they do not conduct. Hence current flows along  $S_2CBDAS_1$  through  $R_L$ . The same process is repeated for subsequent half cycles. It can be seen that, current flows through  $R_L$

in the same direction, during both half cycles of the input a.c. signals. The output signal corresponding to the input signal is shown in Fig 9.17. The efficiency of the bridge rectifier is approximately 81.2%.

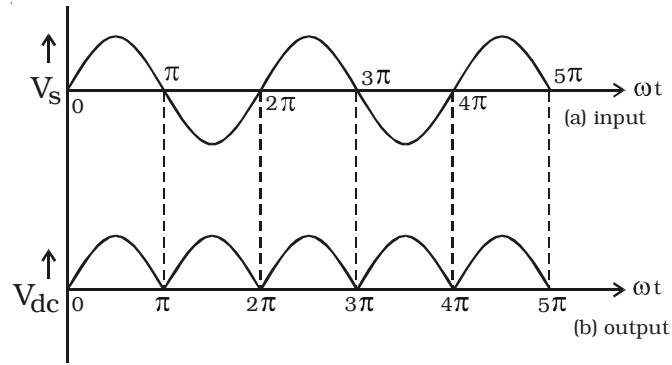

Fig 9.17 Full wave bridge rectifier signals

### 9.3.3 Filter circuits and regulation property of the power supply

Both in half wave and full wave rectifiers, it is observed that the output voltage across  $R_L$  varies from zero to a maximum value. Eventhough, unidirectional current through  $R_L$  is obtained, the output voltage fluctuates. This fluctuation in output voltage is not desirable, when pure d.c. voltage is required. Hence they must be removed or smoothened. This can be achieved with the help of suitable networks called filters such as capacitor filter, inductor filter etc., and we can get almost a steady d.c. voltage. But this steady d.c. output voltage from a rectifier is not constant due to the following reasons.

(i) As the load varies, the d.c. output voltage is not constant. That is, as the current drawn from the rectifier increases, the output voltage decreases and vice versa. The variation of d.c. output voltage as a function of d.c. load current is called regulation.

$$\text{The percentage of regulation} = \frac{V_{no\ load} - V_{load}}{V_{load}} \times 100$$

(ii) The d.c. output voltage varies directly as the a.c. input voltage to the rectifier. The line voltage from a.c. power (220 V) may not be a constant and may vary from 200 V to 240 V. Hence the d.c. output voltage will also vary. To overcome these difficulties, Zener diodes are used as regulators and are used along with rectifier and filter circuits. They are called 'regulated power supplies'.

## 9.4 Breakdown mechanisms

There are two mechanisms which give rise to the breakdown of a PN junction under reverse bias condition. They are (i) avalanche breakdown and (ii) zener breakdown.

**(i) Avalanche breakdown :** When both sides of the PN junction are lightly doped and the depletion layer becomes large, avalanche breakdown takes place. In this case, the electric field across the depletion layer is not so strong. The minority carriers accelerated by the field, collide with the semiconductor atoms in the crystal. Because of this collision with valence electrons, covalent bonds are broken and electron hole pairs are generated. These charge carriers, so produced acquire energy from the applied potential and in turn produce more and more carriers. This cumulative process is called avalanche multiplication and the breakdown is called avalanche breakdown.

**(ii) Zener breakdown :** When both sides of the PN junction are heavily doped, consequently the depletion layer is narrow. Zener breakdown takes place in such a thin narrow junction. When a small reverse bias is applied, a very strong electric field is produced across the thin depletion layer. This field breaks the covalent bonds, extremely large number of electrons and holes are produced, which give rise to the reverse saturation current (Zener current). Zener current is independent of applied voltage.

## 9.5 Zener diode

Zener diode is a reverse biased heavily doped semiconductor (silicon or germanium) PN junction diode, which is operated exclusively in the breakdown region.

The symbol of a Zener diode is shown in Fig 9.18. For normal operation of a Zener diode, in breakdown region, the current through the diode should be limited by an external circuit. Hence the power dissipated across the junction is within its power-handling capacity. Unless this precaution is observed, a large current will destroy the diode.

The V-I characteristic curve for the Zener diode is shown in Fig 9.19. It can be seen from the figure, that, as the reverse voltage applied to the PN junction is increased, at a particular voltage, the

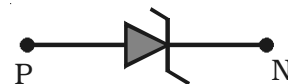

Fig 9.18 Symbol for Zener diode

current increases enormously from its normal cut off value. This voltage is called zener voltage or breakdown voltage ( $V_z$ ).

### 9.6 Zener diode as voltage regulator

To maintain a constant voltage across the load, even if the input voltage or load current varies, voltage regulation is to be made. A Zener diode working in the breakdown region can act as voltage regulator.

The circuit in which a Zener diode is used for maintaining a constant voltage across the load  $R_L$  is shown in Fig 9.20. The Zener diode in reverse biased condition is connected in parallel with the load  $R_L$ . Let  $V_{dc}$  be the unregulated dc voltage and  $V_z$  be Zener voltage (regulated output voltage).  $R_s$  is the current limiting resistor. It is chosen in such a way that the diode operates in the breakdown region.

In spite of changes in the load current or in the input voltage, the Zener diode maintains a constant voltage across the load. The action of the circuit can be explained as given below.

**(i) load current varies, input voltage is constant :** Let us consider that the load current increases. Zener current hence decreases, and the current through the resistance  $R_s$  is a constant. The output voltage is  $V_z = V_{dc} - IR_s$ , since the total current  $I$  remains constant, output voltage remains constant.

**(ii) input voltage varies :** Let us consider that the input voltage  $V_{dc}$  increases. Now the current through Zener increases and voltage drop across  $R_s$  increases in such a way that the load voltage remains the same. Thus the Zener diode acts as a voltage regulator.

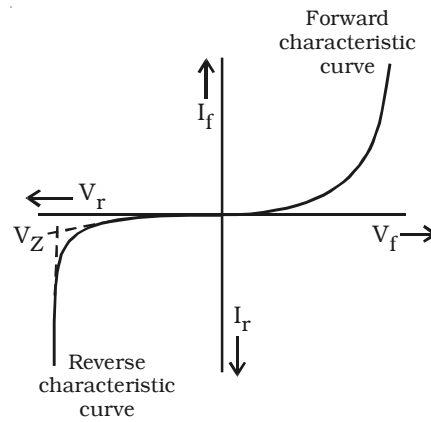

Fig 9.19 V - I characteristics of a Zener diode.

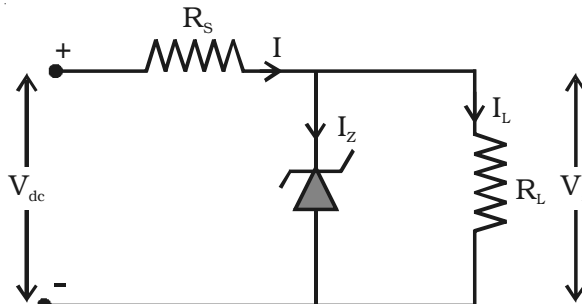

Fig 9.20 Zener diode as a voltage regulator

### 9.7 Light Emitting Diode (LED)

A light emitting diode (LED) is a forward biased PN junction diode, which emits visible light when energized.

When a junction diode is forward biased, electrons from N-side and holes from P-side move towards the depletion region and recombination takes place. When an electron in the conduction band recombines with a hole in the valence band, energy is released. In the case of semiconducting materials like gallium arsenide (GaAs), gallium phosphide (GaP) and gallium - arsenide phosphide (GaAsP), a greater percentage of energy is given out in the form of light. If the semiconductor material is translucent, light is emitted and the junction becomes a light source (turned ON). The LED is turned ON, when it is forward biased and it is turned OFF, when it is reverse biased. The colour of the emitted light will depend upon the type of the material used. By using gallium arsenide phosphide and gallium phosphide, a manufacturer can produce LEDs that radiate red, green, yellow and orange. Fig 9.21 shows the symbol of LED. LEDs are used for instrument displays, calculators and digital watches.

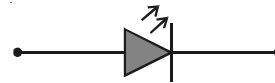

Fig 9.21 Symbol of LED

### 9.8 Junction transistor

A junction transistor is a solid state device. It consists of silicon or germanium crystal containing two PN junctions. The two PN junctions are formed between the three layers. These are called base, emitter and collector.

(i) Base (B) layer : It is a very thin layer, the thickness is about 25 microns. It is the central region of the transistor.

(ii) Emitter (E) and Collector (C) layers : The two layers on the opposite sides of B layer are emitter and collector layers. They are of the same type of the semiconductor.

An ohmic contact is made to each of these layers. The junction between emitter and base is called emitter junction. The junction between collector and base is called collector junction.

In a transistor, the emitter region is heavily doped, since emitter has to supply majority carriers. The base is lightly doped. The collector region is lightly doped. Since it has to accept majority charge



carriers, it is physically larger in size. Hence, emitter and collector cannot be interchanged.

The construction of PNP and NPN transistors are shown in Fig 9.22a and Fig 9.22b respectively.

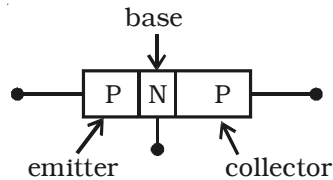

Fig 9.22a Construction of PNP transistor

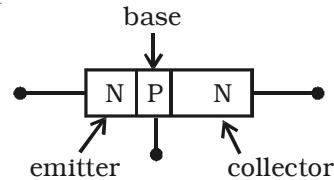

Fig 9.22b Construction of NPN transistor

For a transistor to work, the biasing to be given are as follows :

(i) The emitter-base junction is forward biased, so that majority charge carriers are repelled from the emitter and the junction offers very low resistance to the current.

(ii) The collector-base junction is reverse biased, so that it attracts majority charge carriers and this junction offers a high resistance to the current.

### 9.9 Transistor circuit symbols

The circuit symbols for a PNP and NPN transistors are shown in Fig 9.23. The arrow on the emitter lead pointing towards the base represents a PNP transistor. When the emitter-base junction of a PNP transistor

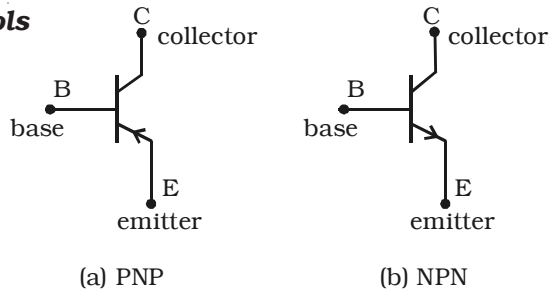

Fig 9.23 Symbol for transistors.

is forward biased, the direction of the conventional current flow is from emitter to base. NPN transistor is represented by arrow on the emitter lead pointing away from the base. When the emitter base junction of a NPN transistor is forward biased, the direction of the conventional current is from base to emitter.

#### 9.9.1 Working of a PNP transistor

A PNP transistor is like two PN junction diodes, which are placed back-to-back. At each junction, there is a depletion region which gives rise to a potential barrier. The external biasing of the junction is

provided by the batteries  $V_{EE}$  and  $V_{CC}$  as shown in Fig. 9.24. The emitter base junction is forward biased and the collector base junction is reverse biased.

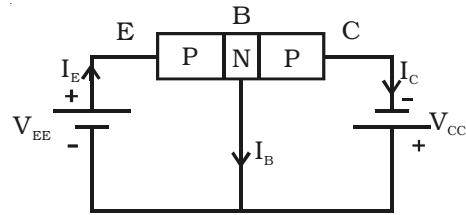

Fig 9.24 PNP Transistor Action

Since the emitter-base junction is forward biased, a large number of holes cross the junction and enters the base. At the same time, very few electrons flow from the base to the emitter. These electrons, when they reach emitter, recombine with an equal number of holes in the emitter. The loss of total number of holes in the emitter is made by flow of an equal number of electrons from the emitter to the positive terminal of the battery. The flow of holes from the emitter to base gives rise to emitter current  $I_E$ . In the emitter,  $I_E$  is due to the flow of holes. But in the external circuit the current is due to the flow of electrons from the emitter to the positive terminal of the battery  $V_{EE}$ . The holes diffuse through the base. These holes take a very small time to flow through this region before they reach the depletion region. During this time, a very small number of holes recombine with an equal number of electrons in the base. Because the base is lightly doped and very thin, this number is very small. The loss of total number of electrons per second is made up by the flow of an equal number of electrons from the negative terminal of  $V_{EE}$  into the base. The flow of these electrons contribute the base current  $I_B$ .

The remaining numbers of holes, which do not undergo recombination process in the base, reach the collector. These are neutralised by an equal number of electrons flowing from the negative terminal of the battery  $V_{CC}$  into the collector. At the same time, an equal number of electrons flows from the negative terminal of  $V_{EE}$  and reach the positive terminal of  $V_{CC}$ . The flow of holes per second from the base to the collector gives rise to the collector current  $I_c$  from the base to the collector. In the external circuit, it is due to the flow of electrons from the negative terminal of the battery  $V_{CC}$  into the collector.

Applying Kirchoff's current law to the circuit, the emitter current is the sum of collector current and base current.

$$\text{i.e } I_E = I_B + I_C$$

This equation is the fundamental relation between the currents in a transistor circuit.

This equation is true regardless of transistor type or transistor configuration.

The action of NPN transistor (Fig 9.25) is similar to that of PNP transistor.

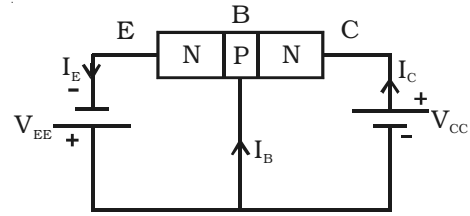

Fig 9.25 NPN transistor action

### 9.9.2 Transistor circuit configurations

There are three types of circuit connections (called configurations or modes) for operating a transistor. They are (i) common base (CB) mode (ii) common emitter (CE) mode and (iii) common collector (CC) mode.

The term common is used to denote the lead that is common to the input and output circuits. The different modes are shown in Fig 9.26 for NPN transistor.

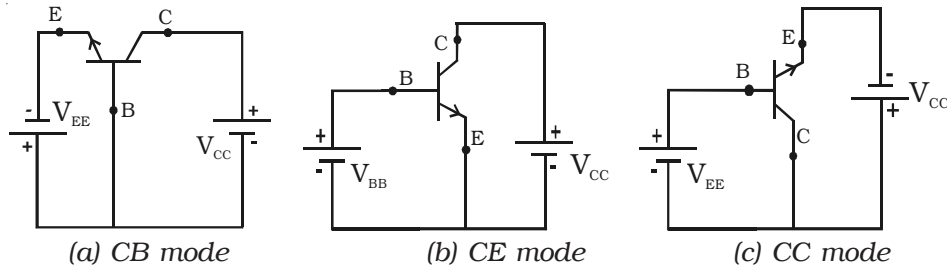

Fig 9.26 Three modes of transistor circuit

In a similar way, three configurations can be drawn for PNP transistor.

### 9.9.3 Current amplification factors $\alpha$ and $\beta$ and the relation between them

The current amplification factor or current gain of a transistor is the ratio of output current to the input current. If the transistor is connected in common base mode, the current gain  $\alpha = \frac{I_C}{I_E}$  and if the transistor is connected in common emitter mode, the current gain  $\beta = \frac{I_C}{I_B}$ . Fig 9.27 shows a NPN transistor connected in the common base and common emitter configurations. Since, 95% of the

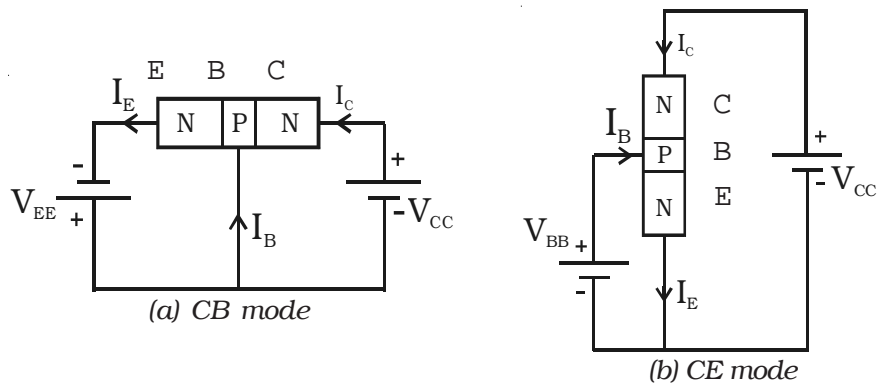

Fig 9.27 CB and CE modes of an NPN transistor

injected electrons reach the collector, the collector current is almost equal to the emitter current. Almost all transistors have  $\alpha$ , in the range 0.95 to 0.99.

We know that

$$\alpha = \frac{I_C}{I_E} = \frac{I_c}{I_B + I_C} \quad (\because I_E = I_B + I_C)$$

$$\frac{1}{\alpha} = \frac{I_B + I_C}{I_C} = \frac{I_B}{I_C} + 1$$

$$\frac{1}{\alpha} - 1 = \frac{1}{\beta}$$

$$\therefore \beta = \frac{\alpha}{1 - \alpha}$$

Usually  $\beta$  lies between 50 and 300. Some transistors have  $\beta$  as high as 1000.

#### 9.9.4 Characteristics of an NPN transistor in common emitter configuration

The three important characteristics of a transistor in any mode are (i) input characteristics (ii) output characteristics and (iii) transfer characteristics.

The circuit to study the characteristic curves of NPN transistor in common emitter mode is as shown in Fig 9.28.

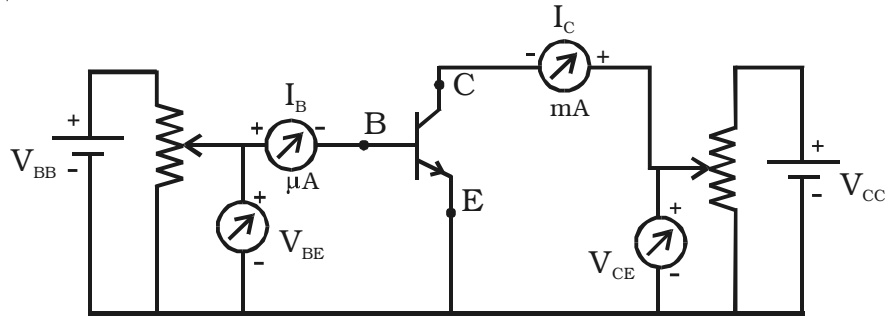

Fig 9.28 Transistor circuit in CE mode.

**(i) Input characteristics**

Input characteristic curve is drawn between the base current ( $I_B$ ) and voltage between base and emitter ( $V_{BE}$ ), when the voltage between collector and emitter ( $V_{CE}$ ) is kept constant at a particular value.  $V_{BE}$  is increased in suitable equal steps and corresponding base current is noted. The procedure is repeated for different values of  $V_{CE}$ .  $I_B$  values are plotted against  $V_{BE}$  for constant  $V_{CE}$ . The input characteristic thus obtained is shown in Fig 9.29.

The input impedance of the transistor is defined as the ratio of small change in base - emitter voltage to the corresponding change in base current at a given  $V_{CE}$ .

$$\therefore \text{Input impedance, } r_i = \left( \frac{\Delta V_{BE}}{\Delta I_B} \right)_{V_{CE}}$$

The input impedance of the transistor in CE mode is very high.

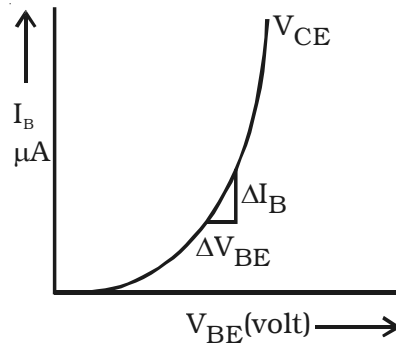

Fig 9.29 Input characteristics

**(ii) Output characteristics**

Output characteristic curves are drawn between  $I_C$  and  $V_{CE}$ , when  $I_B$  is kept constant at a particular value.

The base current  $I_B$  is kept at a constant value, by adjusting the base emitter voltage  $V_{BE}$ .  $V_{CE}$  is increased in suitable equal steps and the corresponding collector current is noted. The procedure is repeated for different values of  $I_B$ . Now,  $I_C$  versus  $V_{CE}$  curves are drawn for different values of  $I_B$ . The output characteristics thus obtained are

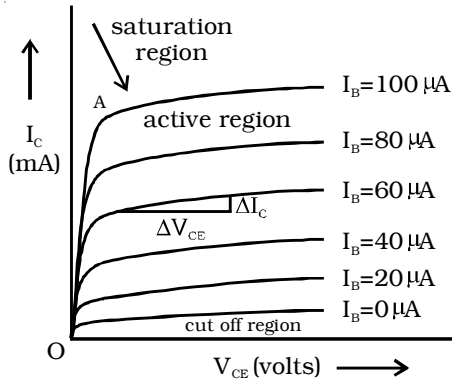

Fig 9.30 Output characteristics

represented in Fig 9.30. The three regions of the characteristics can be discussed as follows :

**Saturation region :** The initial part of the curve (ohmic region, OA) is called saturation region. (i.e) The region in between the origin and knee point. (Knee point is the point, where  $I_C$  is about to become a constant).

**Cut off region :** There is very small collector current in the transistor, even when the base current is zero ( $I_B = 0$ ). In the output characteristics, the region below the curve for  $I_B = 0$  is called cut off region. Below the cut off region, the transistor does not function.

**Active region :** The central region of the curves is called active region. In the active region, the curves are uniform. In this region, E-B junction is forward biased and C-B junction is reverse biased.

The output impedance  $r_o$  is defined as the ratio of variation in the collector emitter voltage to the corresponding variation in the collector current at a constant base current in the active region of the transistor characteristic curves.

$$\therefore \text{output impedance, } r_o = \left( \frac{\Delta V_{CE}}{\Delta I_C} \right)_{I_B}$$

The output impedance of a transistor in CE mode is low.

**(iii) Transfer characteristics**

The transfer characteristic curve is drawn between  $I_C$  and  $I_B$ , when  $V_{CE}$  is kept constant at a particular value. The base current  $I_B$  is increased in suitable steps and the collector current  $I_C$  is noted down for each value of  $I_B$ . The transfer characteristic curve is shown in Fig 9.31.

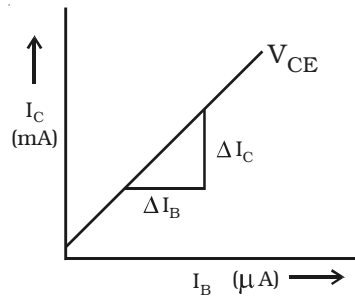

Fig 9.31 Transfer characteristic curve

The current gain is defined as the ratio of a small change in the collector current to the corresponding change in the base current at a constant  $V_{CE}$ .

$$\therefore \text{current gain, } \beta = \left( \frac{\Delta I_C}{\Delta I_B} \right)_{V_{CE}}$$

The common emitter configuration has high input impedance, low output impedance and higher current gain when compared with common base configuration.

### 9.10 Transistor as a switch

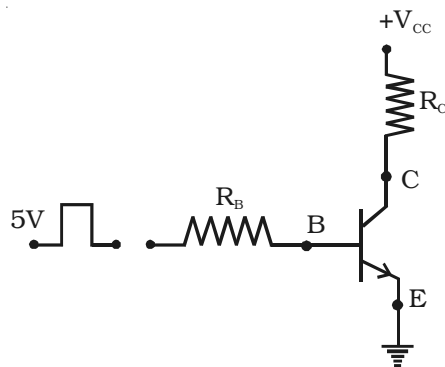

Fig 9.32 NPN Transistor as a switch.

Transistors are widely used in switching operations. In the Fig 9.32, NPN transistor is connected in common emitter configuration and a resistor  $R_B$  is connected in series with the base. The load resistance  $R_C$  is connected in series with the collector. A pulse type waveform is applied as the input to the transistor through  $R_B$ . When the input is high, base emitter junction is forward biased and current flows through  $R_B$

into the base. The values of  $R_B$  and  $R_C$  are chosen in such a manner that the base current flowing, is enough to saturate the transistor. When the transistor is saturated, it is said to be ON (maximum current). When the input is low (i.e.) at 0 V, the base emitter junction is not forward biased. So, no base current flows. Hence the transistor is said to be OFF.

### 9.11 Transistor amplifier

The important function of a transistor is the amplification. An amplifier is a circuit capable of magnifying the amplitude of weak signals. The important parameters of an amplifier are input impedance, output impedance, current gain and voltage gain. A good design of an amplifier circuit must possess high input impedance, low output impedance and high current gain.

#### 9.11.1 Operating point

For the given values of the load resistance  $R_C$  and supply voltage  $V_{CC}$ , two points A ( $V_{CC}$ , 0) and B  $\left(0, \frac{V_{CC}}{R_C}\right)$  are located on the axes of  $V_{CE}$

and  $I_C$  respectively, of the output characteristics of the transistor (Fig 9.33). Joining A and B, load line AB is obtained. The point of intersection Q of this line in the active region of the output characteristics with a suitable value of the base current  $I_B$ , such that the output voltage is symmetrical is called operating point or quiescent point for the amplifier.  $I_{B(Q)}$  is the input base current at the operating point.  $V_{CE(Q)}$  and  $I_{C(Q)}$  are the collector to emitter voltage and the collector current respectively at the operating point.

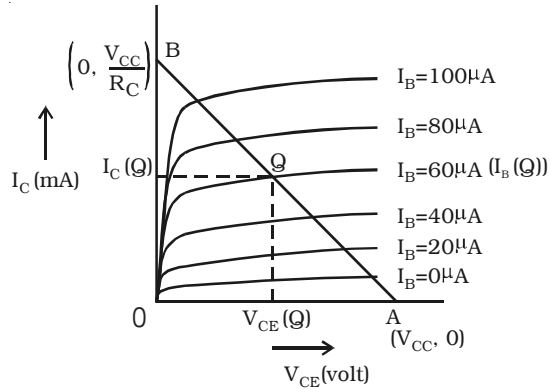

Fig 9.33 load line and operating point

### 9.11.2 Working

A basic circuit of an amplifier in common emitter mode with NPN transistor is shown in Fig 9.34. The emitter-base junction is forward biased by a supply voltage  $V_{BB}$ . The input ac signal to be amplified is applied between base and emitter of the transistor.  $R_C$  is the load resistance.

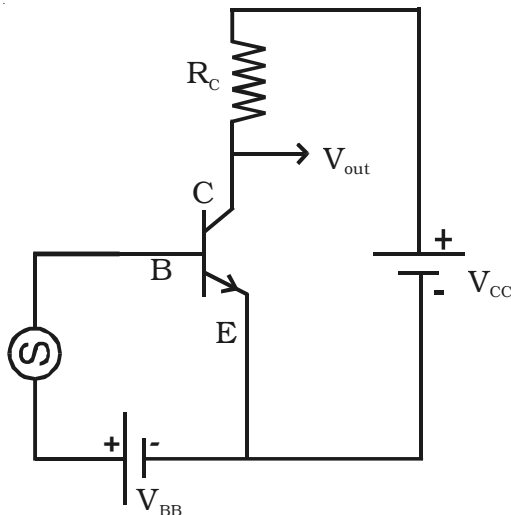

Fig 9.34 Transistor amplifier

The amplifying action of a transistor can be explained as follows. When the a.c. signal is not applied, the base current is available in small quantity in microamperes, which is represented by OP and the corresponding collector current in milliamperes is represented by PQ (Q is the operating point). When the ac signal voltage is applied, the potential difference between the base and emitter changes continuously. This results in



increase of base current ( $I_B$ ) from OP to OA, then decrease of base current from OA to OP (during positive half cycles of the input a.c. voltage) and then to PB and once again increase from OB to OP (during negative half cycle of the input a.c. voltage) for each cycle of the input signal voltage. This variation in base current is reflected in the collector current as shown in Fig 9.35. The collector current ( $I_C$ ) increases from PQ to  $AA_1$ , falls from  $AA_1$  to  $BB_1$  and again increases from  $BB_1$  to PQ. Thus a variation in the base current in micro-amperes produces a corresponding variation in the collector current in milliamperes. This produces a corresponding potential difference across  $R_C$ . The increase of potential difference across  $R_C$  makes a decrease in the output voltage.

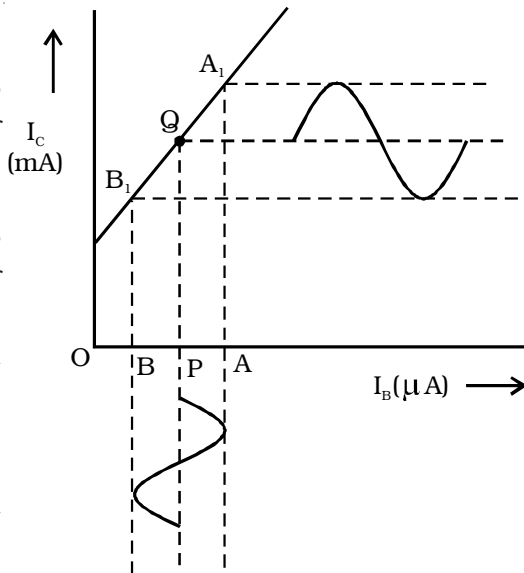

Fig 9.35 Variation in output current ( $I_C$ ) with variation in input current ( $I_B$ )

Therefore, there is always a phase reversal of  $180^\circ$  between the input and output voltages in CE amplifier.

### 9.12 Transistor biasing

In order to amplify the input signal using a transistor, the signal is to be applied at an operating point called  $Q$  point in the active region. Once the operating point is established, its position should not change. If the  $Q$  point shifts near the saturation line or near cut off region of the output characteristics, the signal will be distorted after amplification.

The proper selection of operating point of a transistor and maintenance of proper emitter voltage during the passage of the signal is known as transistor biasing.

The most commonly used methods of obtaining transistor biasing are (i) base bias, (ii) base bias with emitter feedback, (iii) base bias

with collector feedback and (iv) voltage divider bias.

The principle involved in all these types is to obtain the required base current corresponding to the operating point under zero signal conditions.

In all the bias circuits except voltage divider bias, the collector current depends on the current gain ( $\beta$ ) of the transistor. But  $\beta$  of a transistor is very sensitive to temperature changes. For this reason, it is desirable to have a bias circuit whose action is independent of  $\beta$ . The requirement is met by the voltage divider bias circuit.

### 9.12.1 Voltage divider bias

This is the most widely used method of providing bias and stabilization to a transistor. In this method, two resistances  $R_1$  and  $R_2$  are connected across the supply voltage  $V_{CC}$  (Fig 9.36) and provide biasing. The emitter resistance  $R_E$  provides stabilization. The voltage drop across  $R_2$  forward biases the base emitter junction. This causes the base current and hence collector current to flow in zero signal conditions.

The stabilization provided by  $R_E$  can be explained as follows. Since  $\beta$  is very sensitive to temperature changes, the collector current  $I_C$  increases with rise in temperature. Consequently, it can be seen that  $I_E$  increases. This will cause the voltage drop across emitter resistance  $R_E$  to increase. The voltage drop across  $R_2 = V_{BE} + V_{R_E}$ . As voltage drop across  $R_2$  is independent of  $I_C$ ,  $V_{BE}$  decreases. This decreases  $I_B$  and the reduced value of  $I_B$  tends to bring back  $I_C$  to the original value. Hence any variation of  $\beta$  will have no effect on the operating point.

### 9.13 Single stage CE amplifier

Fig 9.37 shows a single stage CE amplifier. The different circuit elements and their functions are described as follows.

(i) Biasing circuit : The resistances  $R_1$ ,  $R_2$  and  $R_E$  form the biasing

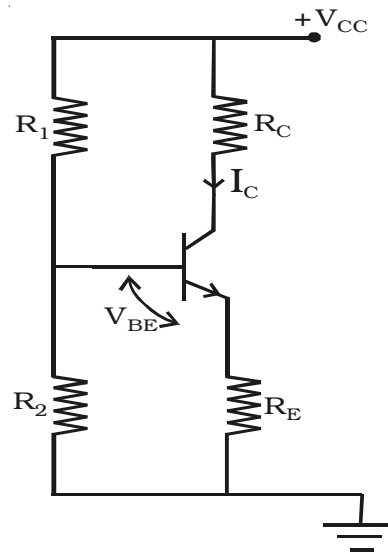

Fig 9.36 Voltage divider bias

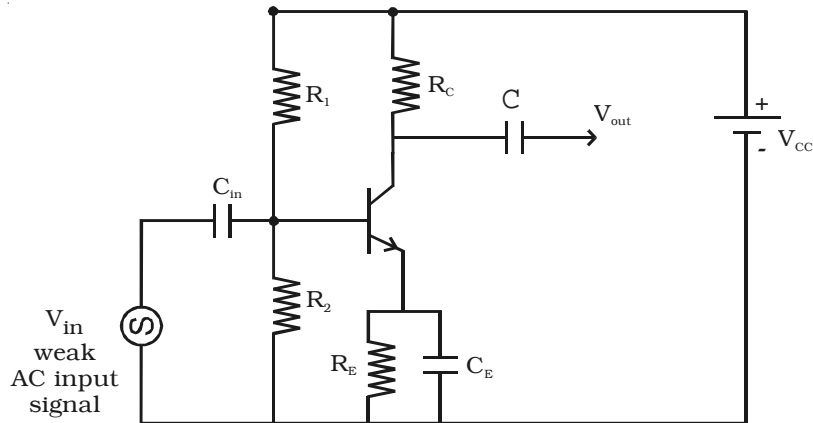

Fig 9.37 Single stage CE amplifier

and stabilization circuit.

(ii) Input capacitance  $C_{in}$  : This is used to couple the signal to the base of the transistor. If this is not used, the signal source resistance will come across  $R_2$  and thus change the bias. The capacitor  $C_{in}$  allows only a.c. signal to flow.

(iii) Emitter bypass capacitor  $C_E$  : This is connected in parallel with  $R_E$  to provide a low reactance path to the amplified a.c. signal. If it is not used, then amplified a.c. signal flowing through  $R_E$  will cause a voltage drop across it, thereby shifting the output voltage.

(iv) Coupling capacitor  $C$  : This is used to couple the amplified signal to the output device. This capacitor  $C$  allows only a.c. signal to flow.

### **Working**

When a weak input a.c. signal is applied to the base of the transistor, a small base current flows. Due to transistor action, a much larger a.c. current flows through collector load  $R_C$ , a large voltage appears across  $R_C$  and hence at the output. Therefore, a weak signal applied to the base appears in amplified form in the collector circuit. Voltage gain ( $A_v$ ) of the amplifier is the ratio of the amplified output voltage to the input voltage.

### **Frequency response and bandwidth**

The voltage gain ( $A_v$ ) of the amplifier for different input frequencies can be determined. A graph can be drawn by taking

frequency ( $f$ ) along X-axis and voltage gain ( $A_v$ ) along Y-axis. The frequency response curve obtained will be of the form as shown in Fig 9.38. It can be seen that the gain decreases at very low and very high frequencies, but it remains constant over a wide range of mid-frequency region.

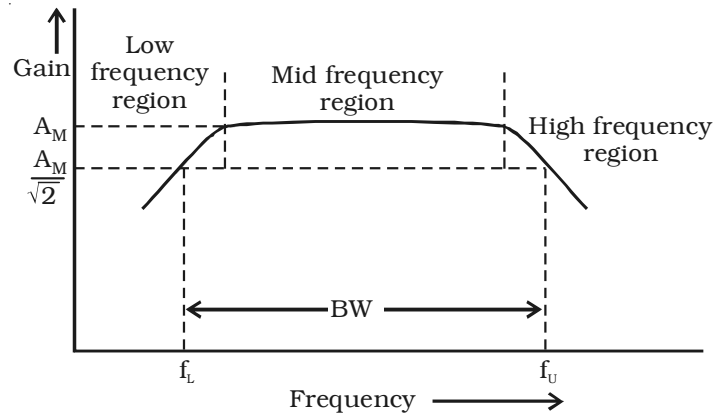

Fig 9.38 Frequency response curve

Lower cut off frequency ( $f_L$ ) is defined as the frequency in the low frequency range at which the gain of the amplifier is  $\frac{1}{\sqrt{2}}$  times the mid frequency gain ( $A_M$ ). Upper cut off frequency ( $f_U$ ) is defined as the frequency in the high frequency range at which the gain of the amplifier is  $\frac{1}{\sqrt{2}}$  times the mid frequency gain ( $A_M$ ).

Bandwidth is defined as the frequency interval between lower cut off and upper cut off frequencies.

$$\therefore \text{BW} = f_U - f_L$$

#### 9.14 Multistage amplifiers

The amplification of a signal by a single amplifier may not be enough in most of the practical cases. Hence in these cases, two or more amplifiers are used in series to get sufficient amplified signal. The amplifiers are coupled in such a manner that the output of the first stage becomes the input for the next stage. Connecting the amplifiers in this manner is known as cascading the stages. When a number of amplifiers are connected in cascade, the overall voltage gain is equal to the product of voltage gain of individual stages.

In general the output terminals of one stage cannot be connected directly to the input of the next stage. A suitable coupling network is required to connect two stages. This coupling network should not permit the dc voltage at the output of one stage to pass into the input of the next stage. Otherwise the biasing condition of the second stage will be upset. Further the loss of voltage, when the signal passes from one stage to the next must be minimum. The three coupling devices generally used are

- (i) Resistance - Capacitance (RC) coupling
- (ii) Transformer coupling
- (iii) Direct coupling

RC coupling scheme consist of a series capacitor C and a parallel resistor R. C acts as a short circuit for ac signals while it behaves like an open circuit for dc signals. In transformer coupling scheme, the transformer ensures that the ac signal is transformed from the amplifier to the load, while at the same time, insulating the load from the dc signals. When dc signals have to be amplified, direct coupling is the simplest and the best to use.

### **9.15 Feedback in amplifiers**

The characteristics of an amplifier are highly dependent on transistor parameters like current gain, input impedance and output impedance etc. The transistor parameters exhibit variations due to ageing of transistors. Manufacturing processes cause variations in parameters of transistors of the same type. To overcome any adverse effect on the overall performance of an amplifier, feedback is used. Feedback is said to exist in an amplifier circuit, when a fraction of the output signal is returned or fed back to the input and combined with the input signal. If the magnitude of the input signal is reduced by the feed back, the feed back is called negative or degenerative. If the magnitude of the input signal is increased by the feed back, such feed back is called positive or regenerative.

#### **9.15.1 Principle of feedback amplifier**

For an ordinary amplifier i.e. without feedback, let  $V_0$  and  $V_i$  be the output voltage and input voltage respectively. If A be the voltage gain of the amplifier, then

$$A = \frac{V_0}{V_i}$$

The gain  $A$  is often called as open-loop gain.

The general theory of feedback can be explained with the help of block diagram shown in Fig 9.39. The feedback amplifier has two parts (i.e) amplifier and feedback circuit. The feedback circuit usually consists of passive components (resistor, capacitor, inductor). A fraction (say  $\beta$ ) of the output voltage is fed back to the input through the feedback circuit. Let  $V'_o$  be the output voltage with feedback.

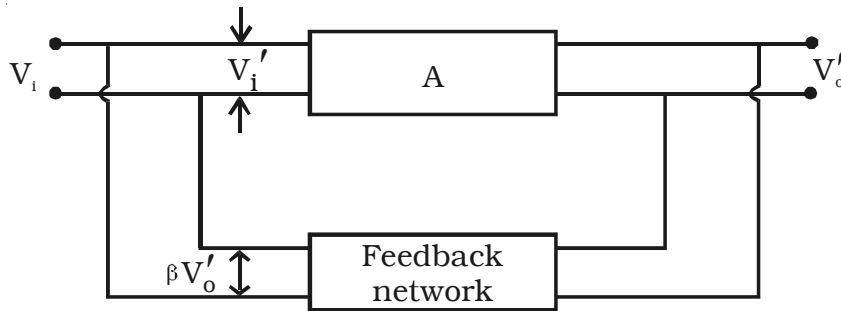

Fig 9.39 Feedback amplifier

Therefore, after feedback the input voltage  $V'_i$  becomes,

$$V'_i = V_i \pm \beta V'_o \quad \dots (1)$$

For positive feedback,  $\beta$  is taken as positive. For negative feedback,  $\beta$  is taken as negative.

For positive feedback, the input voltage will be  $V_i + \beta V'_o$ . When this is amplified  $A$  times by the amplifier, the output voltage after feedback ( $V'_o$ ) will be  $A(V_i + \beta V'_o)$

$$\therefore V'_o = A (V_i + \beta V'_o) \quad \dots (2)$$

$$V'_o (1 - \beta A) = AV_i \quad \dots (3)$$

Then the voltage gain of the amplifier with feedback is

$$A_f = \frac{V'_o}{V_i} = \frac{A}{1 - \beta A} \quad \dots (4)$$

Since  $|1 - \beta A| < 1$ ,  $A_f > A$ . The positive feedback increases the amplifier gain.

For negative feedback, the feedback fraction is  $-\beta$

$$\therefore A_f = \frac{A}{1 - (-A\beta)} = \frac{A}{1 + A\beta}$$

Since  $|1 + \beta A| > 1$ ,  $A_f < A$ . Therefore negative feedback reduces the amplifier gain.

The term  $A\beta$  is called loop gain and  $\beta$  is called feedback ratio.

### **9.15.2 Advantages of negative feedback**

Following are the advantages of negative feedback.

- (i) Highly stabilised gain.
- (ii) Reduction in the noise level.
- (iii) Increased bandwidth
- (iv) Increased input impedance and decreased output impedance.
- (v) Less distortion.

### **9.16 Transistor oscillators**

An oscillator may be defined as an electronic circuit which converts energy from a d.c. source into a periodically varying output. Oscillators are classified according to the output voltage, into two types viz. sinusoidal and non-sinusoidal oscillators. If the output voltage is a sine wave function of time, the oscillator is said to be sinusoidal oscillator. If the oscillator generates non-sinusoidal waveform, such as square, rectangular waves, then it is called as non-sinusoidal oscillator (multivibrator). The oscillators can be classified according to the range of frequency as audio-frequency (AF) and radio-frequency (RF) oscillators.

Sinusoidal oscillators may be any one of the following three types:

- (i) LC oscillators
- (ii) RC oscillators
- (iii) Crystal oscillators

#### **9.16.1 Barkhausen condition for oscillation**

The gain of the amplifier with positive feedback is given by

$$A_f = \frac{A}{1 - A\beta}, \text{ where } A \text{ is the voltage gain without feedback, } \beta \text{ is}$$

the feedback ratio and  $A\beta$  is the loop gain. When  $A\beta = 1$ , then  $A_f \rightarrow \infty$ . This means that output voltage is obtained, even if input voltage is zero, (i.e) it becomes an oscillator. The essential condition for the maintenance of oscillation is  $A\beta = 1$ .

This condition means that (i) the loop gain  $A\beta = 1$  and (ii) the net phase shift round the loop is  $0^\circ$  or integral multiples of  $2\pi$ .

These are called the Barkhausen conditions for oscillations.

### 9.16.2 Generation of sinusoidal waves by a tuned LC circuit

Sinusoidal oscillators consist of two main sections : a frequency determining device and maintaining device. A resonant LC network can be used as frequency determining device. The frequency maintaining device is a transistor amplifier with its power supply. The amplifier must have sufficient gain to compensate for the attenuation of the frequency determining section and must introduce required phase shift for positive feedback.

If a capacitor of capacitance  $C$  and an inductor of inductance  $L$  are connected in parallel, then such a circuit represents an oscillatory circuit.

Let us consider a fully charged capacitor  $C$  connected with an inductance  $L$  as shown in Fig 9.40a. When the charged capacitor is connected to inductance  $L$ , the capacitor will discharge, sending current through  $L$  and induce magnetic field as shown in Fig 9.40b. Thus the electrostatic energy stored in the capacitor has been converted into electromagnetic energy associated with inductance  $L$ .

When the capacitor is completely discharged, the induced magnetic field begins to collapse, sending current in the same direction. The capacitor  $C$  is now charged with opposite polarity (Fig 9.40c). In this case, energy associated with magnetic field is converted

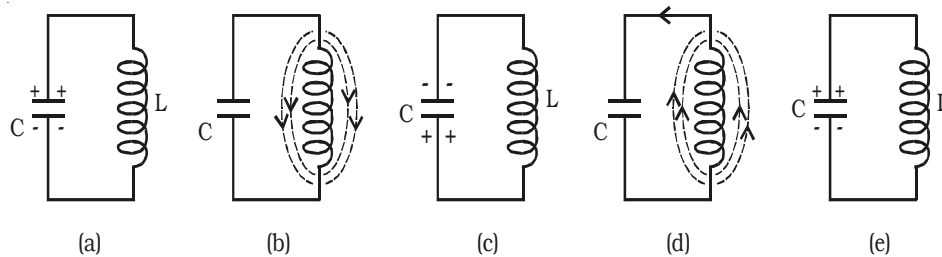

Fig 9.40 Tuned LC circuit



into electrostatic energy. This energy is stored in the capacitor. Once the capacitor is completely charged, it begins to discharge in the reverse direction producing again a magnetic field across L in the opposite direction (Fig 9.40d). Again the magnetic field will collapse and will charge the capacitor. The circuit returns to the original state. (Fig 9.40e). This charging and discharging process results in oscillating current and hence electrical oscillations are set up in the LC circuit. When a LC circuit is used to store energy, it is called tank circuit. The frequency of oscillations is given by,

$$f = \frac{1}{2\pi\sqrt{LC}}$$

If there are no power losses in the LC circuit, then the electrical oscillations will continue for indefinite time. But, in practice, there is some power loss during each cycle of oscillation, as some resistance is always associated with a given LC circuit. Hence the amplitude of oscillations decreases gradually and becomes zero, when all the energy is consumed as losses. Therefore, damped oscillations are produced in the circuit (Fig 9.41a).  $I_{\max}$  represents the maximum current flowing through the circuit.

In order to make the oscillations undamped, energy must be supplied to the circuit at the same rate, at which it is dissipated. The energy supplied should be in phase with oscillations set up in LC circuit. The applied energy should have the same frequency as that of

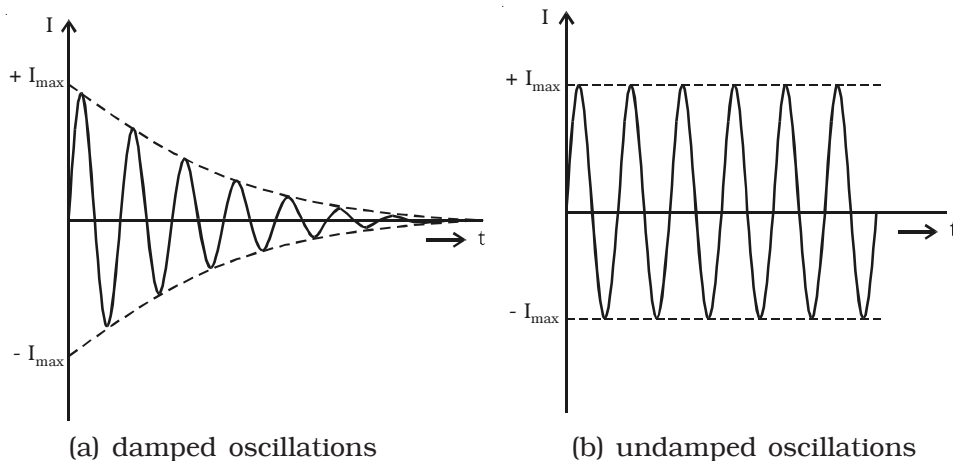

Fig 9.41 Oscillations

oscillations in the tank circuit. If these conditions are fulfilled, the circuit will produce continuous undamped oscillations (Fig 9.41b).

### 9.16.3 Essentials of LC oscillator

Fig 9.42 shows the block diagram of an oscillator. Its essential components are (i) tank circuit, (ii) amplifier and (iii) feedback circuit.

(i) Tank circuit : It consists of inductance coil (L) connected in parallel with capacitor (C). The frequency of oscillations in the circuit depends upon the values of inductance coil and capacitance of the capacitor.

(ii) Amplifier : The transistor amplifier receives d.c. power from the battery and changes it into a.c. power for supplying to the tank circuit.

(iii) Feedback circuit : It provides positive feedback (i.e.) this circuit transfers a part of output energy to LC circuit in proper phase, to maintain the oscillations.

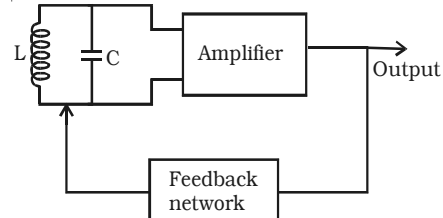

Fig 9.42 Oscillator block diagram

### 9.16.4 LC oscillators

A transistor can work as an LC oscillator to produce undamped oscillations of any desired frequency, if tank and feedback circuits are properly connected to it. There are different LC oscillators used in electronic circuits, of which, the working principle of Colpitt's oscillator is discussed here.

#### Colpitt's oscillator

The circuit diagram of Colpitt's oscillator is shown in Fig 9.43. The resistance  $R_1$ ,  $R_2$  and  $R_E$  provide the sufficient bias for the circuit.

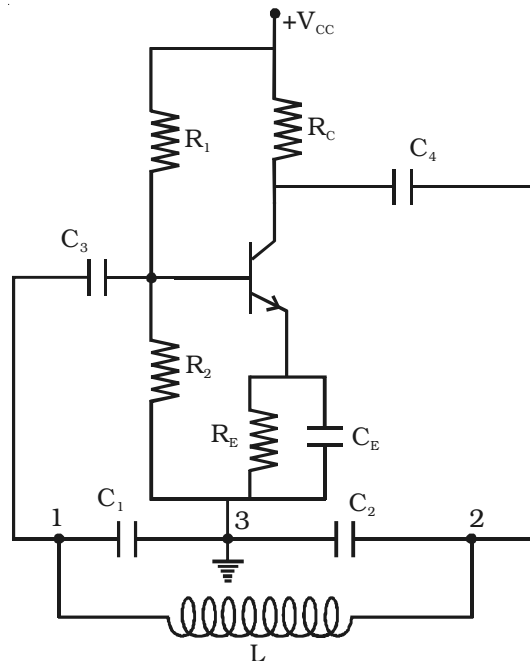

Fig 9.43 Colpitt's oscillator

The frequency determining network is the parallel resonant circuits consisting of capacitors  $C_1$ ,  $C_2$  and the inductor  $L$ . The junction of  $C_1$  and  $C_2$  is earthed. The function of the capacitor  $C_4$  is to block d.c and provide an a.c. path from the collector to the tank circuit. The voltage developed across  $C_1$  provides the positive feedback for sustained oscillations.

**Working**

When the collector supply voltage is switched on, a transient current is produced in the tank circuit and damped harmonic oscillations are produced. The oscillations across  $C_1$  are applied to the base emitter junction and appear in the amplified form in the collector circuit. If terminal 1 is at positive potential with respect to terminal 3 at any instant, then terminal 2 will be at negative potential with respect to 3, since 3 is grounded. Hence points 1 and 2 are  $180^\circ$  out of phase. The amplifier produces further phase shift of  $180^\circ$ . Thus the total phase shift is  $360^\circ$ . In other words, energy supplied to the tank circuit is in phase with the oscillations and if  $A\beta = 1$ , oscillations are sustained in the circuit.

The frequency of oscillations is given by  $f = \frac{1}{2\pi\sqrt{LC}}$

$$\text{where } C = \frac{C_1 C_2}{C_1 + C_2}$$

$$\therefore f = \frac{1}{2\pi} \sqrt{\frac{(C_1 + C_2)}{LC_1 C_2}}$$

**9.17 Integrated circuit (IC)**

An integrated circuit (IC) consists of a single – crystal chip of silicon, containing both active (diodes and transistors) and passive (resistors, capacitors) elements and their interconnections. ICs have the following advantages over the discrete components:

- (i) Extremely small in size
- (ii) Low power consumption
- (iii) Reliability
- (iv) Reduced cost
- (v) Very small weight
- (vi) Easy replacement

ICs offer a wide range of applications and they are broadly classified as digital ICs and linear ICs\*. Two distinctly different IC technologies have been employed which are monolithic and hybrid technology.

In monolithic integrated circuits, all circuit components both active and passive elements and their inter connections are made on the top of a single silicon chip. The monolithic circuit is ideal for applications in the situations, where identical currents are received in large quantities. Hence it provides lowest cost per unit and highest order of reliability. In hybrid circuits, separate component parts are attached to a ceramic substrate and the components are interconnected by means of either metallization pattern or wire bonds.

Typical chip sizes range from about  $40 \times 40$  mils (a mil is 0.001 inch) to about  $300 \times 300$  mils depending on the complexity of the circuit. Any number of components from very few in number to thousands can be fabricated on a single chip. The integrated circuits are available in Dual-in-line package (DIP).

### 9.18 Digital electronics

The term digital is derived from the way in which computers perform operations using digits. Initially, applications of digital electronics were confined to computer systems. Nowadays, digital techniques are applied in many areas, such as telephony, radar, medical instruments, navigation and military systems etc. Digital Electronics involves circuits and systems in which there are only two possible states which are represented by voltage levels. Other circuit conditions such as current levels, open or closed switches can also represent the two states.

#### **Analog signal**

The signal current or voltage is in the form of continuous, time varying voltage or current (sinusoidal). Such signals are called continuous or analog signals. A typical analog signal is shown in Fig 9.44.

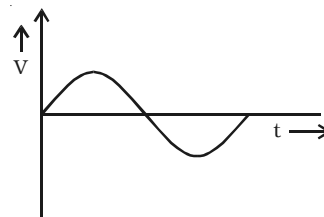

Fig 9.44 Analog signal

---

**Digital ICs** : The integrated circuits which process the digital signals are called digital ICs.

**Linear ICs** : The integrated circuits which process the analog signals are called linear ICs.

### **Digital signal and logic levels**

A digital signal (pulse) is shown in Fig 9.45. It has two discrete levels, 'High' and 'Low'. In most cases, the more positive of the

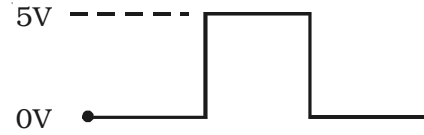

Fig 9.45 Digital Signal

two levels is called HIGH and is also referred to as logic 1. The other level becomes low and also called logic 0. This method of using more positive voltage level as logic 1 is called a positive logic system. A voltage 5V refers to logic 1 and 0 V refers to logic 0. On the other hand, in a negative logic system, the more negative of the two discrete levels is taken as logic 1 and the other level as logic 0. Both positive and negative logic are used in digital systems. But, positive logic is more common of logic gates. Hence we consider only positive logic for studying the operation of logic gates.

#### **9.18.1 Logic gates**

Circuits which are used to process digital signals are called logic gates. They are binary in nature. Gate is a digital circuit with one or more inputs but with only one output. The output appears only for certain combination of input logic levels. Logic gates are the basic building blocks from which most of the digital systems are built up. The numbers 0 and 1 represent the two possible states of a logic circuit. The two states can also be referred to as 'ON and OFF' or 'HIGH and LOW' or 'TRUE and FALSE'.

#### **9.18.2 Basic logic gates using discrete components**

The basic elements that make up a digital system are 'OR', 'AND' and 'NOT' gates. These three gates are called basic logic gates. All the possible inputs and outputs of a logic circuit are represented in a table called TRUTH TABLE. The function of the basic gates are explained below with circuits and truth tables.

##### **(i) OR gate**

An OR gate has two or more inputs but only one output. It is known as OR gate, because the output is high if any one or all of the inputs are high. The logic symbol of a two input OR gate is shown in Fig 9.46a.

The Boolean expression to represent OR gate is given by  $Y = A + B$  (+ symbol should be read as OR)

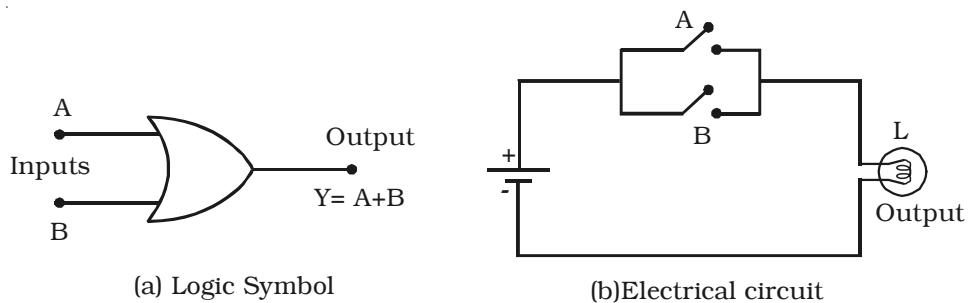

Fig 9.46 OR gate

The OR gate can be thought of like an electrical circuit shown in Fig 9.46b, in which switches are connected in parallel with each other. The lamp will glow if both the inputs are closed or any one of them is closed.

**Diode OR gate**

Fig 9.47 shows a simple circuit using diodes to build a two input OR gate. The working of this circuit can be explained as follows.

Case (i)  $A = 0$  and  $B = 0$

When both A and B are at zero level, (i.e.) low, the output voltage will be low, because the diodes are non-conducting.

Case (ii)  $A = 0$  and  $B = 1$

When A is low and B is high, diode  $D_2$  is forward biased so that current flows through  $R_L$  and output is high.

Case (iii)  $A = 1$  and  $B = 0$

When A is high and B is low, diode  $D_1$  conducts and the output is high.

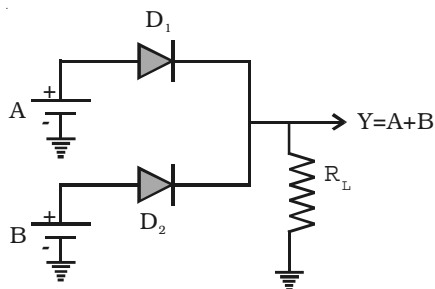

Fig 9.47 OR gate using diodes

Table 9.1 Truth table of OR gate

Inputs		Output
A	B	$Y = A + B$
0	0	0
0	1	1
1	0	1
1	1	1

Case (iv)  $A = 1$  and  $B = 1$

When  $A$  and  $B$  both are high, both diodes  $D_1$  and  $D_2$  are conducting and the output is high. Therefore  $Y$  is high. The OR gate operations are shown in Table 9.1.

**(ii) AND gate**

An AND gate has two or more inputs but only one output. It is known as AND gate because the output is high only when all the inputs are high. The logic symbol of a two input AND gate is shown in Fig 9.48a.

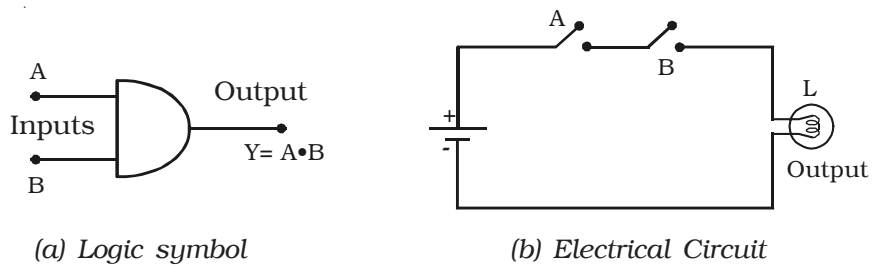

Fig 9.48 AND gate

The Boolean expression to represent AND gate is given by  $Y = A \cdot B$  ( $\cdot$  should be read as AND)

AND gate may be thought of an electrical circuit as shown in Fig 9.48b, in which the switches are connected in series. Only if  $A$  and  $B$  are closed, the lamp will glow, and the output is high.

**Diode AND gate**

Fig 9.49 shows a simple circuit using diodes to build a two-input AND gate. The working of the circuit can be explained as follows :

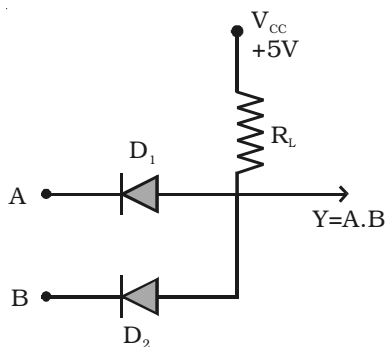

Fig 9.49 AND gate using diodes

Table 9.2 Truth table of AND gate

Inputs		Output
A	B	$Y = A \cdot B$
0	0	0
0	1	0
1	0	0
1	1	1

Case (i)  $A = 0$  and  $B = 0$

When  $A$  and  $B$  are zero, both diodes are in forward bias condition and they conduct and hence the output will be zero, because the supply voltage  $V_{CC}$  will be dropped across  $R_L$  only. Therefore  $Y = 0$ .

Case (ii)  $A = 0$  and  $B = 1$

When  $A = 0$  and  $B$  is high, diode  $D_1$  is forward biased and diode  $D_2$  is reverse biased. The diode  $D_1$  will now conduct due to forward biasing. Therefore, output  $Y = 0$ .

Case (iii)  $A = 1$  and  $B = 0$

In this case, diode  $D_2$  will be conducting and hence the output  $Y = 0$ .

Case (iv)  $A = 1$  and  $B = 1$

In this case, both the diodes are not conducting. Since  $D_1$  and  $D_2$  are in OFF condition, no current flows through  $R_L$ . The output is equal to the supply voltage. Therefore  $Y = 1$ .

Thus the output will be high only when the inputs  $A$  and  $B$  are high. The Table 9.2 summarises the function of an AND gate.

**(iii) NOT gate (Inverter)**

The NOT gate is a gate with only one input and one output. It is so called, because its output is complement to the input. It is also known as inverter. Fig 9.50a shows the logic symbol for NOT gate.

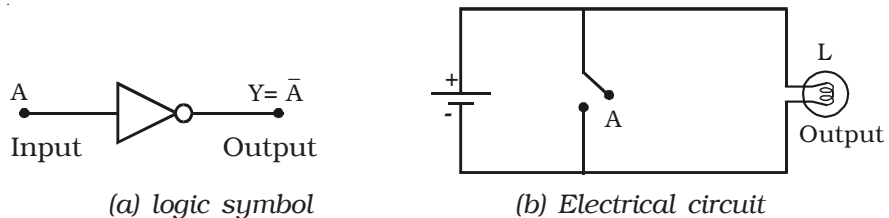

Fig 9.50 NOT gate

The Boolean expression to represent NOT operation is  $Y = \bar{A}$ .

The NOT gate can be thought of like an electrical circuit as shown in Fig 9.50b. When switch  $A$  is closed, input is high and the bulb will not glow (i.e) the output is low and vice versa.

Fig 9.51 is a transistor in CE mode, which is used as NOT gate. When the input  $A$  is high, the transistor is driven into saturation and



hence the output Y is low. If A is low, the transistor is in cutoff and hence the output Y is high. Hence, it is seen that whenever input is high, the output is low and vice versa. The operation of NOT gate is shown in Table 9.3.

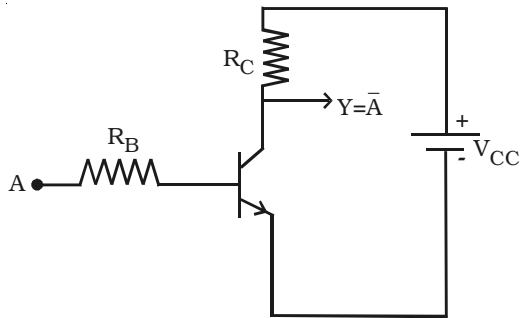

Table 9.3 Truth Table of NOT gate

Input	Output
A	$Y = \bar{A}$
0	1
1	0

Fig 9.51 NOT gate using transistor

### 9.18.3 Exclusive OR gate (EXOR gate)

The logic symbol for exclusive OR (EXOR) gate is shown in Fig 9.52a.

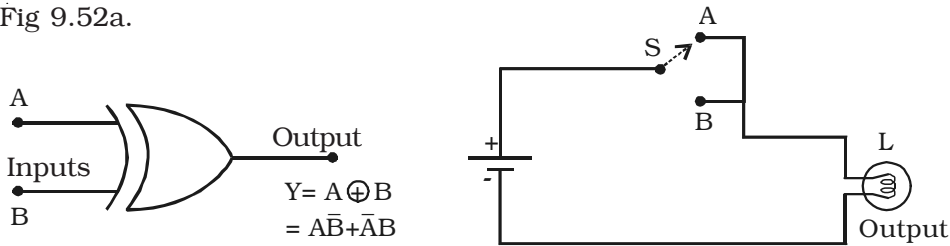

(a) Logic symbol

(b) Electrical circuit

Fig 9.52 Exclusive OR gate

The Boolean expression to represent EXOR operation is

$$Y = A \oplus B = A\bar{B} + \bar{A}B$$

EXOR gate has an output 1, only when the inputs are complement to each other. The equivalent switching circuit is shown in Fig 9.52b.

Switch positions A and B will individually make the lamp to be ON. But the combination of A and B is not possible.

The EXOR operation is represented in Table 9.4.

Table 9.4 Truth table of EXOR gate

Inputs		Output
A	B	$Y = A \oplus B$
0	0	0
0	1	1
1	0	1
1	1	0

### 9.18.4 NAND gate

This is a NOT-AND gate. It can be obtained by connecting a NOT gate at the output of an AND gate (Fig 9.53a).

The logic symbol for NAND gate is shown in Fig 9.53b.

The Boolean expression to represent NAND Operation is  $Y = \overline{AB}$

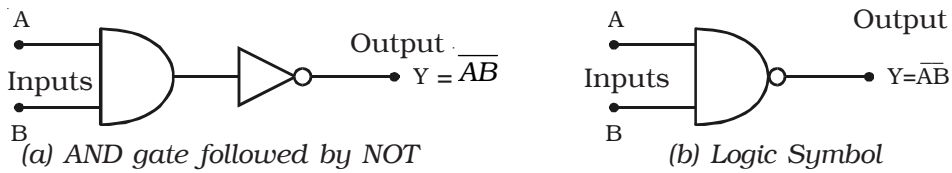

Fig 9.53 NAND gate

NAND gate function is reverse of AND gate function. A NAND gate will have an output, only if both inputs are not 1. In other words, it gives an output 1, if either A or B or both are 0. The operation of a NAND gate is represented in Table 9.5.

Table 9.5 Truth table of NAND gate

Inputs		Output
A	B	$Y = \overline{AB}$
0	0	1
0	1	1
1	0	1
1	1	0

### 9.18.5 NOR gate

This is a NOT-OR gate. It can be made out of an OR gate by connecting an inverter at its output (Fig 9.54a).

The logic symbol for NOR gate is given in Fig 9.54b.

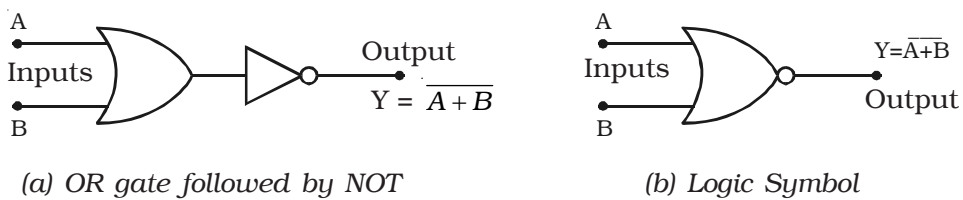

Fig 9.54 NOR gate

The Boolean expression to represent NOR gate is  $Y = \overline{A+B}$

The NOR gate function is the reverse of OR gate function. A NOR gate will have an output, only when all inputs are 0. In a NOR gate, output is high, only when all inputs are low. The NOR operation is represented in Table 9.6.

Table 9.6 Truth table of NOR gate

Inputs		Output
A	B	$Y = \overline{A+B}$
0	0	1
0	1	0
1	0	0
1	1	0

### 9.18.6 De-Morgan's theorems

The two De Morgan's theorems are very important in dealing with NOR and NAND gates. They state that a NOR gate that performs the  $\overline{A+B}$  function is equivalent to the function  $\overline{A} \cdot \overline{B}$  and NAND gate, that performs the  $\overline{A \cdot B}$  function is equivalent to the function  $\overline{A+B}$ .

#### First theorem

"The complement of a sum is equal to the product of the complements." If A and B are the inputs, then  $\overline{A+B} = \overline{A} \cdot \overline{B}$

#### Second theorem

"The complement of a product is equal to the sum of the complements." If A and B are the inputs, then  $\overline{A \cdot B} = \overline{A+B}$ .

The theorems can be proved, first by considering the two variable cases and then extending this result as shown in Table 9.7.

Table 9.7 Truth table to prove De-Morgan's theorems

A	B	$\overline{A}$	$\overline{B}$	$\overline{A \cdot B}$	$\overline{A+B}$	$\overline{A+B}$	$\overline{A} \cdot \overline{B}$
0	0	1	1	1	1	1	1
0	1	1	0	1	1	0	0
1	0	0	1	1	1	0	0
1	1	0	0	0	0	0	0

### 9.18.7 NAND and NOR as Universal gates

NAND and NOR gates are called Universal gates because they can perform all the three basic logic functions. Table 9.8 gives the construction of basic logic gates NOT, OR and AND using NAND and NOR gates.

**Table 9.8 Substituting NAND / NOR gates**

Logic function	Symbol	Circuits using NAND gates only	Circuits using NOR gates only
NOT			
OR			
AND			

### 9.18.8 Boolean algebra

Boolean algebra, named after a mathematician George Boole is the algebra of logic, which is applied to the operation of computer devices. The rules of this algebra is simple, speed and accurate. This algebra is helpful in simplifying the complicated logical expression.

#### Laws and theorems of Boolean algebra

The fundamental laws of Boolean algebra are given below which are necessary for manipulating different Boolean expressions.

*Basic laws :*

Commutative laws

$$A + B = B + A$$

$$AB = BA$$

Associative Laws

$$A + (B + C) = (A + B) + C$$

$$A (BC) = (AB) C$$

Distributive law

$$A(B+C) = AB + AC$$

*New operations :*

$$A + 0 = A$$

$$A + 1 = 1$$

$$A \cdot 0 = 0$$

$$A \cdot 1 = A$$

$$A + A = A$$

$$A + \bar{A} = 1$$

$$A \cdot A = A$$

$$A \cdot \bar{A} = 0$$

$$\bar{\bar{A}} = A$$

*Special theorems :*

$$A + AB = A$$

$$(A + B)(A + C) = A + BC$$

$$A(A + B) = A$$

$$A + \bar{A}B = A + B$$

$$A(\bar{A} + B) = AB$$

$$(A + B)(\bar{A} + C) = AC + \bar{A}B$$

$$AB + \bar{A}C = (A + C)(\bar{A} + B)$$

Theorems involving a single variable can be proved by considering every possible value of the variable. For example considering theorem  $A + 0 = A$ ,

If  $A = 0$  then,  $0 + 0 = 0 = A$

and if  $A = 1$  then,  $1 + 0 = 1 = A$

and hence the theorem is proved.

Theorems involving more than one variable can be proved by making a truth table. For example, theorem  $A + AB = A$  can be proved by making the Truth table given in Table 9.9.

**Table 9.9 Truth table to prove theorem  $A + AB = A$**

<b>A</b>	<b>B</b>	<b>AB</b>	<b>A + AB</b>
0	0	0	0
0	1	0	0
1	0	0	1
1	1	1	1

From the Table 9.9, it is observed that there are 4 possible combinations of the two variables A and B. For each combination the value of A is the same as that of  $A + AB$ , which proves the theorem.

### 9.18.9 Simplification of Boolean expression

By manipulating a Boolean expression according to laws and theorems of Boolean algebra, a simple expression that will require fewer gates, can be obtained.

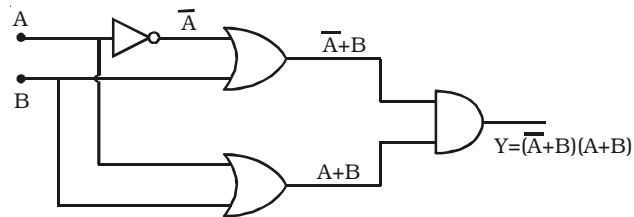

Fig 9.55 Simplification of Boolean expression

To see how Boolean algebra manipulation is used to simplify digital circuits, let us consider the following example.

In the circuit given in Fig 9.55, the outputs of the OR gates are  $\bar{A} + B$  and  $A + B$ . These are the inputs for the AND gate and the output of the circuit is  $Y = (\bar{A} + B)(A + B)$ .

Now using the distributive law twice, we can write

$$\begin{aligned} (\bar{A} + B)(A + B) &= \bar{A}A + \bar{A}B + BA + BB \\ &= \bar{A}B + AB + B \quad (\because \bar{A}A = 0 \text{ and } BB = B) \\ &= B(\bar{A} + A + 1) = B \quad (\because \bar{A} + A + 1 = 1) \end{aligned}$$

Since the output of the circuit is simply B, we don't need a logic circuit.

### 9.19 Operational amplifier (OP - AMP)

Linear integrated circuits are being used in a number of electronic applications, such as in the fields like communication, medical electronics, instrumentation control etc. An important linear IC is an operational amplifier.

OP-AMP is a solid state device capable of sensing and amplifying dc and ac input signals. OP-AMP is an amplifier with two inputs (differential inputs) and a single output. OP-AMP consists of 20 transistors, 11 resistors and one capacitor. It usually requires a positive and negative power supply (dual power supply). This allows the output voltage to swing positive and negative with respect to ground.

The most important characteristics of OP-AMP are : (i) very high input impedance or even infinity which produces negligible current at the inputs, (ii) very high gain, (iii) very low output impedance or even zero, so as not to affect the output of the amplifier by loading.

An OP-AMP is so named, because it was originally designed to perform mathematical operations such as addition, subtraction, multiplication, division, integration, differentiation etc in analog computer. Nowadays OP-AMPs are used in analog computer operations and in timing circuits.

### 9.19.1 Circuit symbol and Pin-out configuration of an OP-AMP

The OP – AMP is represented by a triangular symbol as shown in Fig 9.56. It has two input terminals and one output terminal. The terminal with *negative* sign is called as the inverting input and the

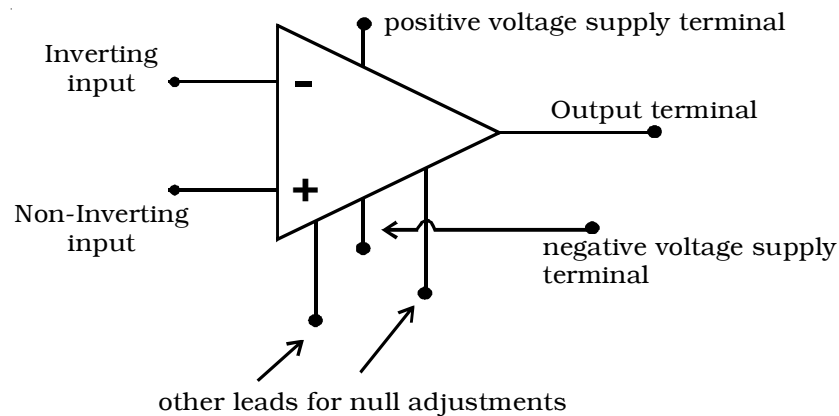

Fig 9.56 Symbol for OP-AMP

terminal with *positive* sign is called as the non-inverting input. The input terminals are at the base of the triangle. The output terminal is shown at the apex of the triangle.

The widely used very popular type Op-Amp IC 741, which is available in DIP. Referring to the top view of the dual-in-package, the pin configuration of IC 741 can be described (Fig 9.57) as follows. The top pin on the left side of the notch indicates Pin 1. The pin number 2 is inverting input terminal and 3 is non-inverting input terminal. Pin 6 is the output terminal. A d.c. voltage or a.c signal placed on the inverting input will be  $180^\circ$  out of phase at the output. A d.c. voltage or a.c. signal placed on the non-inverting input will be

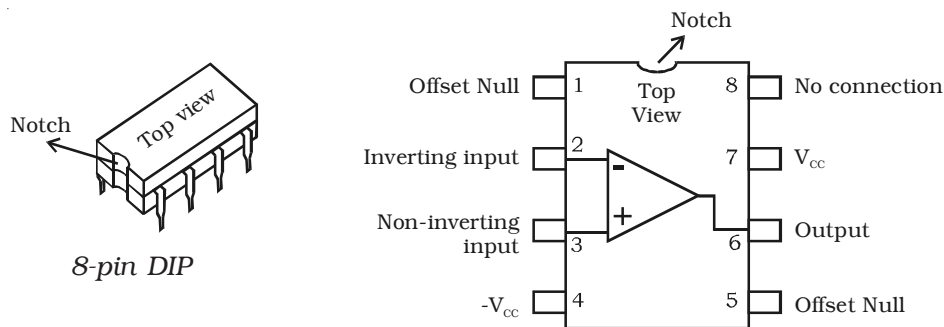

Fig 9.57 OP-AMP Pin-out configuration

inphase at the output. Pins 7 and 4 are the power supply terminals. Terminals 1 and 5 are used for null adjustment. Null adjustment pins are used to null the output voltage when equal voltages are applied to the input terminals for perfect balance. Pin 8 indicates no connection.

### 9.19.2 Basic OP-AMP circuits

This section concentrates on the principles involved with basic OP-AMP circuit viz, (i) inverting and (ii) non-inverting amplifiers.

#### (i) Inverting amplifier

The basic OP-AMP inverting amplifier is shown in Fig 9.58. The input voltage  $V_{in}$  is applied to the inverting input through the input resistor  $R_{in}$ . The non inverting input is grounded. The feedback resistor  $R_f$  is connected between the output and the inverting input.

Since the input impedance of an op-amp is considered very high, no current can flow into or out of the input terminals. Therefore  $I_{in}$  must flow through  $R_f$  and is indicated by  $I_f$  (the feedback current). Since  $R_{in}$  and  $R_f$  are in series, then  $I_{in} = I_f$ . The voltage between inverting and non-inverting inputs

is essentially equal to zero volt. Therefore, the inverting input terminal is also at 0 volt. For this reason the inverting input is said to be at virtual ground. The output voltage ( $V_{out}$ ) is taken across  $R_f$ .

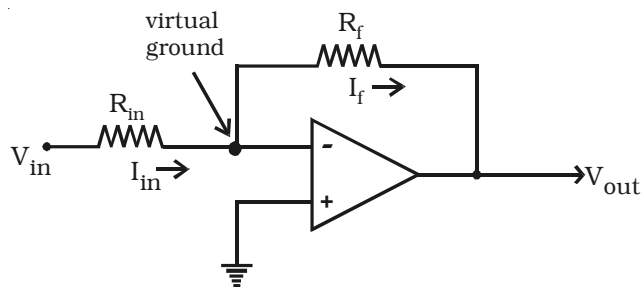

Fig 9.58 Inverting amplifier



It can be proved that

$$I_f = -\frac{V_{out}}{R_f}$$

Since  $I_{in} = I_f$ , then

$$\frac{V_{in}}{R_{in}} = \frac{-V_{out}}{R_f}$$

Rearranging the equation, we obtain

$$\frac{-V_{out}}{V_{in}} = \frac{R_f}{R_{in}}$$

∴ The voltage gain of an inverting amplifier can be expressed as

$$A_v = \frac{-R_f}{R_{in}}$$

The amplifier gain is the ratio of  $R_f$  to  $R_{in}$ .

Finally, the output voltage can be found by

$$V_{out} = \frac{-R_f}{R_{in}} \times V_{in}$$

The output voltage is out of phase with the input voltage.

### (ii) Non-inverting amplifier

The basic OP-AMP non-inverting amplifier is shown in Fig 9.59. The input signal  $V_{in}$  is applied to the non-inverting input terminal. The resistor  $R_{in}$  is connected from the inverting input to ground. The feedback resistor  $R_f$  is connected between the output and the inverting input.

Resistors  $R_f$  and  $R_{in}$  form a resistive ratio network to produce the feedback voltage ( $V_A$ ) needed at the inverting input. Feedback voltage ( $V_A$ ) is developed across  $R_{in}$ . Since the potential at the inverting input

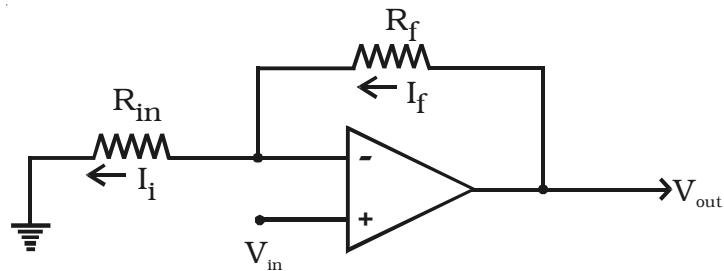

Fig 9.59 Non-inverting amplifier

tends to be the same as the non-inverting input (as pointed out with the description of virtual ground),  $V_{in} = V_A$ .

Since  $V_A = V_{in}$ , the gain of the amplifier can be expressed as

$$A_v = \frac{V_{out}}{V_A}$$

However,  $V_A$  is determined by the resistance ratio of  $R_{in}$  and  $R_f$ ; thus,

$$V_A = \frac{R_{in}}{R_f + R_{in}} V_{out}$$

$$(or) \quad \frac{V_{out}}{V_A} = \frac{R_f + R_{in}}{R_{in}}$$

$$\frac{V_{out}}{V_A} = 1 + \frac{R_f}{R_{in}}$$

$$\therefore A_v = 1 + \frac{R_f}{R_{in}}$$

Finally, the output voltage can be found by,  $V_{out} = \left(1 + \frac{R_f}{R_{in}}\right) V_{in}$

It is seen that the input and output voltages are in phase.

### 9.19.3 Summing amplifier

The summing amplifier provides an output voltage equal to the algebraic sum of the input voltages.

Fig 9.60 shows an inverting amplifier, used to sum two input voltages. The input voltages  $v_1$  and  $v_2$  are applied through the resistors  $R_1$  and  $R_2$  to the summing junction (P) and  $R_f$  is the feedback resistor. At the point P,

$$i_1 + i_2 = i_f$$

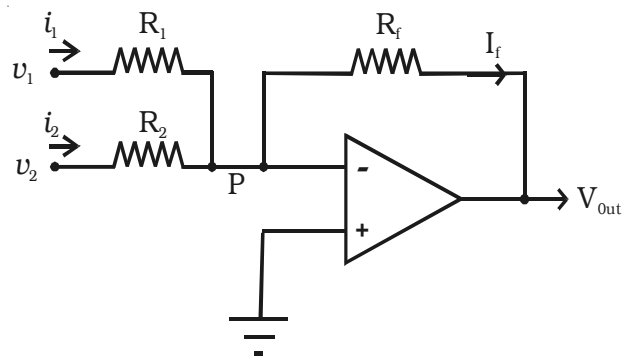

Fig 9.60 Summing amplifier

Since the voltage at the point P is ideally 0,

$$\frac{v_1}{R_1} + \frac{v_2}{R_2} = -\frac{v_{out}}{R_f}$$

Hence the output voltage,

$$v_{out} = -\left(\frac{R_f}{R_1}v_1 + \frac{R_f}{R_2}v_2\right)$$

If  $R_1 = R_2 = R_f = R$ , then  $v_{out} = -(v_1 + v_2)$

Hence the output voltage is equal to the sum of the input voltages and the circuit acts as a summing amplifier. The negative sign indicates that OP-AMP is used in the inverting mode.

#### 9.19.4 Difference amplifier

The difference amplifier is shown in Fig 9.61. The output voltage can be obtained by using superposition principle. To find the output voltage  $v_{O1}$  due to  $v_1$  alone, assume that  $v_2$  is shorted to ground. Then

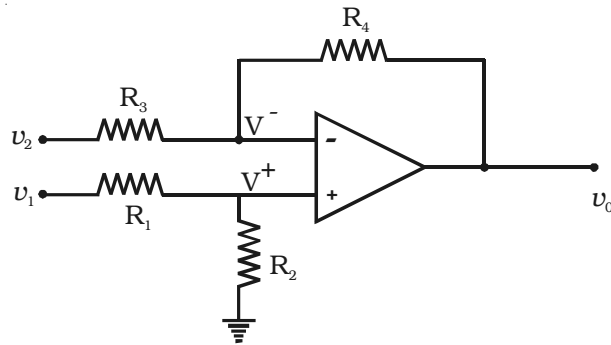

Fig 9.61 Difference amplifier

$$V^+ = \frac{R_2}{R_1 + R_2}v_1$$

$$\text{and } v_{O1} = \frac{R_3 + R_4}{R_3}V^+ = \left(\frac{R_3 + R_4}{R_3}\right)\left(\frac{R_2}{R_1 + R_2}\right)v_1$$

Now assuming that  $v_1$  is shorted to ground, the output voltage  $v_{O2}$  due to  $v_2$  alone is given by,

$$v_{O2} = -\frac{R_4}{R_3}v_2$$

Therefore, with both inputs present, the output is

$$\begin{aligned} v_o &= v_{01} + v_{02} \\ &= \left( \frac{R_3 + R_4}{R_3} \right) \left( \frac{R_2}{R_1 + R_2} \right) v_1 - \left( \frac{R_4}{R_3} \right) v_2 \end{aligned}$$

If  $R_1 = R_2 = R_3 = R_4 = R$

then  $v_o = v_1 - v_2$

If all the external resistors are equal, the voltage difference amplifier functions as a voltage subtractor.

### 9.20 Electronic measuring instruments

The active and passive elements in an electronic circuit should be tested for their correctness and reliability before making electrical connections with them. Electronic circuits should be tested for their performance. Electronic measuring instruments are used for this purpose. Measurement or testing is done by measuring current, voltage, resistance, capacitance, etc. The construction and working of a few measuring instruments such as cathode ray oscilloscope and multimeter are discussed in the following sections.

#### 9.20.1 Cathode ray oscilloscope (CRO)

This device is the most useful electronic instrument. This gives visual representation of electrical quantities such as voltage and frequency in any electronic circuit. It makes use of the properties of cathode rays, which are deflected in electric and magnetic fields and produce scintillation on fluorescent screen (Fig 9.62).

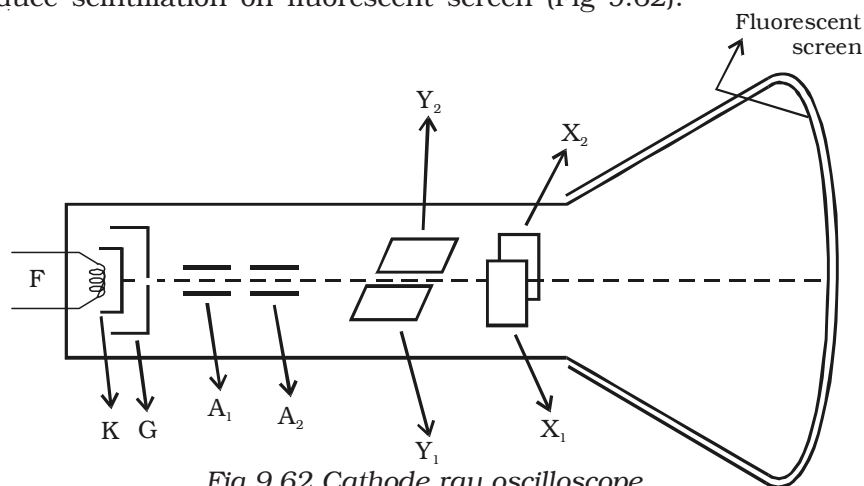

Fig 9.62 Cathode ray oscilloscope

CRO consists of three sections (i) an electron gun (ii) a deflection system (iii) a fluorescent screen. These are enclosed in a glass tube, which is completely evacuated.

**(i) Electron gun**

The electron gun consists of a cathode K, a control grid G and along with them two anodes  $A_1$  and  $A_2$ . Electrons which are emitted from the indirectly heated cathode K, passes through the hole in the cylindrical grid G, towards the anode. Due to the negative potential of G with respect to cathode, these electrons bunch together, forming a beam of electrons coming out of G. The electron beam is accelerated by the two cylindrical anodes  $A_1$  and  $A_2$ . Then the electron beam strikes the fluorescent screen.

**(ii) Deflection system**

With the help of two pairs of the plates  $X_1$ ,  $X_2$  and  $Y_1$ ,  $Y_2$ , the electron beam travelling towards the screen can be deflected. These plates are placed between the path of the beam beyond the anode  $A_2$ .  $Y_1$ ,  $Y_2$  plates are called Y-plates and  $X_1$ ,  $X_2$  plates are called X-plates. The Y plates are kept horizontal and X plates kept vertical along the direction of the beams.

The electron beam will be deflected along the vertical direction, if a DC potential is applied to Y plates and the electron beam will be deflected along the horizontal direction, with the potential on X-plates.

**(iii) Fluorescent screen**

The glass tube is coated with a fluorescent material. When the beam strikes the screen a light spot is visible. The electrons striking the screen are returned to the power supply via the inner surfaces of the glass envelope, usually coated with graphite. This coating is connected to anode  $A_2$  by a lead-in wire.

**Uses**

- (i) It is used to measure a.c and d.c voltage.
- (ii) It is used to study the waveforms of a.c voltages.
- (iii) It is used to find the frequency of a.c voltage.
- (iv) It is used to study the beating of heart in cardiology.

### 9.20.2 Multimeter

Multimeter is an electronic instrument, which is used to measure voltage, current and resistance. This is called as AVO meter (ampere, voltage, ohm). The internal circuit of the multimeter is shown in Fig 9.63. It consists of a moving coil galvanometer. By incorporating suitable circuits with the galvanometer, the measurement of voltage, current and resistance can be done. Let us consider a galvanometer of resistance  $G (= 100 \Omega)$ , which gives a full scale deflection for 1 mA.

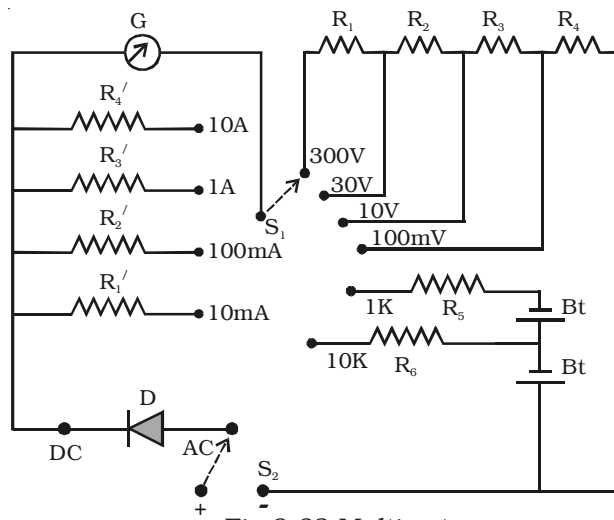

Fig 9.63 Multimeter

#### (a) as a voltmeter

The moving coil galvanometer is converted into a voltmeter by connecting in series a high resistance of suitable value. If a resistance of  $900 \Omega$  is connected in series with the galvanometer, the range of the voltmeter becomes  $10^{-3} \times 1000 = 1 \text{ V}$ . The same meter can be used to measure voltage upto 10 V, if a resistance  $9900 \Omega$  is connected in series. Thus, in order to measure different ranges, different high resistances are put in series with the galvanometer by a switching arrangement.

#### (b) as an ammeter

The galvanometer is converted into an ammeter by shunting it with suitable low resistances, one for each range. For example, the

galvanometer can be converted into an ammeter with range 0-1 A by shunting it with a resistance of  $100/999 \Omega$  or  $0.1 \Omega$  (approximately) and the range can be increased to 10 A by shunting it with  $100/9999 \Omega$  ( $0.01 \Omega$  approximately) and so on.

**(c) as an ohm-meter**

The galvanometer is converted into an ohm-meter by connecting a battery and a suitable resistance in series (Fig 9.64). If a battery of 1 V is connected in series and the above galvanometer shows full scale deflection, then the total resistance in the circuit (including that of the galvanometer) be  $1000 \Omega$ .

**Measurement of resistance**

On the resistance scale 0 is marked against the current of 1 mA. Now, if a unknown resistance is connected between the terminals  $T_1$  and  $T_2$ , the current passing through the galvanometer decreases to 0.5 mA, then the unknown resistance is  $1000 \Omega$ . Hence,  $1 \text{ k} \Omega$  is marked against 0.5 mA. If the galvanometer current is 0.25 mA for another unknown resistance connected between  $T_1$  and  $T_2$ , then that resistance is  $3000 \Omega$ . Hence,  $3 \text{ k} \Omega$  is marked against 0.25 mA.

Usually an adjustable resistance of small value is connected in series, so that the zero adjustment can be made, even if the emf of the cell decreases slightly.

To measure a.c. voltage and current, a rectifier unit is connected in series and by turning a switch to a.c., the instrument is used to measure a.c. quantities. If the switch is turned to d.c., the rectifier unit gets disconnected and the instrument is then used to measure d.c. current and voltage.

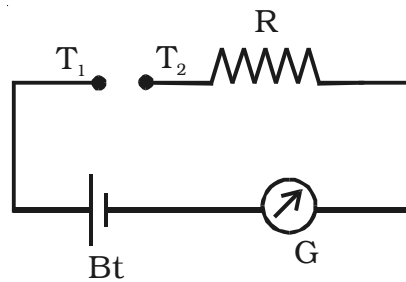
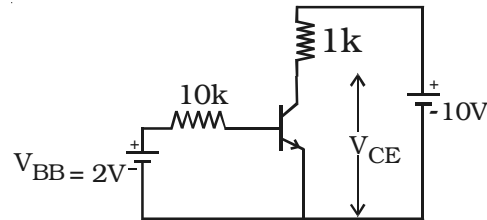

Fig 9.64 Measurement of resistance

### Solved Problems

- 9.1 The current gain  $\beta$  of the silicon transistor used in the circuit as shown in figure is 50. (Barrier potential for silicon is 0.69 V)



Find (i)  $I_B$  (ii)  $I_E$  (iii)  $I_C$  and (iv)  $V_{CE}$

**Data :**

$$V_{BB} = 2 \text{ V}, V_{CC} = 10 \text{ V}; \beta = 50$$

$$R_B = 10 \text{ k}\Omega ; R_C = 1 \text{ k}\Omega$$

The barrier potential for silicon transistor  $V_{BE} = 0.69 \text{ V}$

**Solution :**  $V_{BB} = I_B R_B + V_{BE}$

$$I_B = \frac{V_{BB} - V_{BE}}{R_B} = \frac{2 - 0.69}{10 \times 10^3} = 131 \mu\text{A}$$

$$\text{Current gain } \beta = \frac{I_C}{I_B}$$

$$I_C = I_B \beta = 131 \times 10^{-6} \times 50 = 6.5 \text{ mA}$$

$$\begin{aligned} \text{Emitter current } I_E &= I_C + I_B \\ &= 6.5 \text{ mA} + 131 \mu\text{A} \\ &= 6.5 \text{ mA} + 0.131 \text{ mA} \\ &= 6.631 \text{ mA} \end{aligned}$$

$$V_{CC} = V_{CE} + I_C R_C$$

$$\begin{aligned} V_{CE} &= V_{CC} - I_C R_C \\ &= 10 - (6.5 \times 10^{-3} \times 1 \times 10^3) \\ &= 3.5 \text{ V} \end{aligned}$$

- 9.2 A transistor is connected in CE configuration. The voltage drop across the load resistance ( $R_C$ ) 3 k $\Omega$  is 6 V. Find the base current. The current gain  $\alpha$  of the transistor is 0.97

**Data :** Voltage across the collector load resistance ( $R_C$ ) = 6 V

$$\alpha = 0.97; R_C = 3 \text{ k}\Omega$$



**Solution :** The voltage across the collector resistance is,  $R_C = I_C R_C = 6V$

$$\text{Hence, } I_C = \frac{6}{R_C} = \frac{6}{3 \times 10^3} = 2\text{mA}$$

$$\text{Current gain } \beta = \frac{\alpha}{1-\alpha} = \frac{0.97}{1-0.97} = 32.33$$

$$\therefore I_B = \frac{I_C}{\beta} = \frac{2 \times 10^{-3}}{32.33} = 61.86 \mu\text{A}$$

- 9.3 When the negative feedback is applied to an amplifier of gain 50, the gain after feedback falls to 25. Calculate the feedback ratio.

**Data :**  $A = 50$  ;  $A_f = 25$

**Solution :** Voltage gain after feedback,

$$A_f = \frac{A}{1 + A\beta}$$

$$25 = \frac{50}{1 + 50\beta}$$

Hence, the feedback ratio  $\beta = 0.02$

- 9.4 Prove the Boolean identity ;  $(A+B)(A+C) = A+BC$

**Solution :** Proof : Applying the law of distribution on LHS of the equation, we get

$$\begin{aligned} (A+B)(A+C) &= AA + AC + BA + BC \\ &= A + AC + AB + BC = A(1+C+B) + BC = A + BC \\ & \quad [ \because 1 + C + B = 1 ] \end{aligned}$$

$\therefore$  LHS = RHS, the given identity is proved.

- 9.5 The outputs of two NOT gates are NORed, as shown in figure. What is this combination equivalent to?

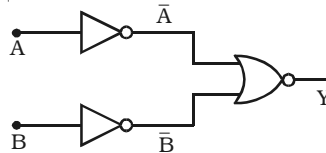

**Solution :** From the logic circuit it follows that the output

$$y = \overline{\overline{A + B}}$$

Applying DeMorgan's first theorem,

$$\text{we get, } y = \overline{\overline{A}} \cdot \overline{\overline{B}} = AB$$

Hence given logic circuit is AND operation.

9.6 Construct a logic circuit using NAND gates only for  $Y = \overline{A} + \overline{BC}$

**Solution :** Each and every term in the given logic expression is replaced by the corresponding basic gates using NAND gates.

Hence, the logic circuit for  $Y = \overline{A} + \overline{BC}$  using NAND gates is given below

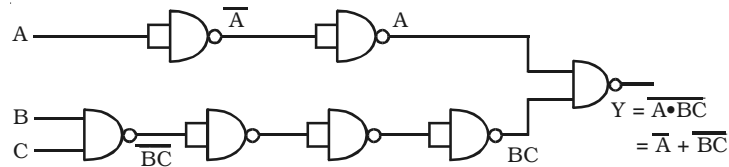

$\therefore \overline{\overline{A}} = A$ , the above logic circuit can be simplified as,

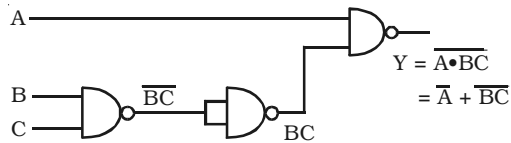

9.7 Determine the output wave form for the circuit given below, if the input waveforms are as indicated by A and B.

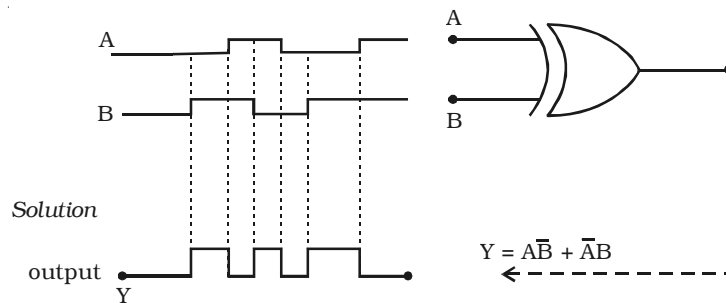

9.8 Find the output of the ideal operational amplifier shown in the figure for each of the following input signals

- a)  $V_{in} = 120 \text{ mV dc}$
- b)  $V_{in} = 0.5 \sin \omega t$
- c)  $V_{in} = -2.5 \text{ V dc}$
- d)  $V_{in} = 4 - \sin \omega t \text{ V}$
- e)  $V_{in} = 0.8 \sin (\omega t + 75^\circ) \text{ V}$

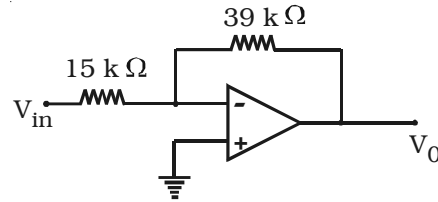

**Data :**  $R_f = 39 \text{ k}\Omega$ ;  $R_1 = 15 \text{ k}\Omega$

**Solution :** The gain of the amplifier  $A_v = -\frac{R_f}{R_{in}} = -\frac{39 \times 10^3}{15 \times 10^3} = -2.6$

$$\begin{aligned} \text{a) output of the OP.AMP } (V_o) &= -\frac{R_f}{R_{in}} \times V_{in} \\ &= -2.6 \times 120 \times 10^{-3} = -0.312 \text{ V} \end{aligned}$$

$$\text{b) } V_o = -2.6 \times (0.5 \sin \omega t) = -1.3 \sin \omega t \text{ ac}$$

$$\text{c) } V_o = -2.6 \times (-2.5 \text{ V}) = +6.5 \text{ V d.c.}$$

$$\text{d) } V_o = -2.6 (4 - \sin \omega t \text{ V}) = -10.4 + 2.6 \sin \omega t \text{ V}$$

$$\text{e) } V_o = -2.6 [(0.8 \sin (\omega t + 75^\circ) \text{ V})] = -2.08 \sin (\omega t + 75^\circ) \text{ V}$$

9.9 Find the output of the circuit given below

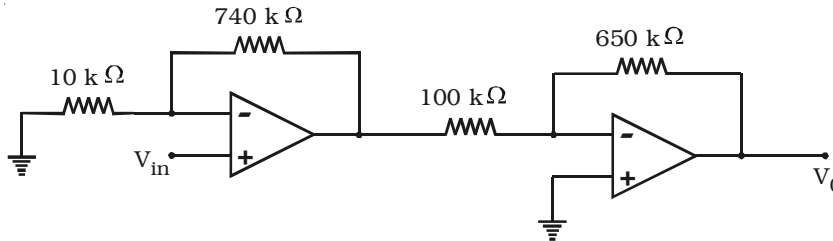

**Data :**  $R_f = 740 \text{ k}\Omega$  ;  $R_f' = 650 \text{ k}\Omega$  ;  $R_1 = 10 \text{ k}\Omega$  ;  
 $R_1' = 100 \text{ k}\Omega$

**Solution :**

Let  $V_1$  be the output voltage of the first amplifier

$$V_1 = \left(1 + \frac{R_f}{R_1}\right) V_{in} = \left(1 + \frac{740 \times 10^3}{10 \times 10^3}\right) V_{in} = 75 V_{in}$$

$$\therefore V_o = -\left(\frac{R_f'}{R_{in}}\right) V_1 = -\left(\frac{650 \times 10^3}{100 \times 10^3}\right) 75 V_{in} = -487.5 V_{in}$$

## **Self evaluation**

**(The questions and problems given in this self evaluation are only samples. In the same way any question and problem could be framed from the text matter. Students must be prepared to answer any question and problem from the text matter, not only from the self evaluation.)**

- 9.1 The electrons in the atom of an element which determine its chemical and electrical properties are called  
(a) valence electrons                      (b) revolving electrons  
(c) excess electrons                        (d) active electrons
- 9.2 In an N-type semiconductor, there are  
(a) immobile negative ions      (b) no minority carriers  
(c) immobile positive ions      (d) holes as majority carriers
- 9.3 The reverse saturation current in a PN junction diode is only due to  
(a) majority carriers                      (b) minority carriers  
(c) acceptor ions                          (d) donor ions
- 9.4 In the forward bias characteristic curve, a diode appears as  
(a) a high resistance                      (b) a capacitor  
(c) an OFF switch                         (d) an ON switch
- 9.5 Avalanche breakdown is primarily dependent on the phenomenon of  
(a) collision                                      (b) ionisation  
(c) doping                                         (d) recombination
- 9.6 The colour of light emitted by a LED depends on  
(a) its reverse bias                          (b) the amount of forward current  
(c) its forward bias                         (d) type of semiconductor material
- 9.7 The emitter base junction of a given transistor is forward biased and its collector-base junction is reverse biased. If the base current is increased, then its  
(a)  $V_{CE}$  will increase                      (b)  $I_C$  will decrease  
(c)  $I_C$  will increase                         (d)  $V_{CC}$  will increase.
- 9.8 Improper biasing of a transistor circuit produces  
(a) heavy loading of emitter current  
(b) distortion in the output signal  
(c) excessive heat at collector terminal  
(d) faulty location of load line

- 9.9 An oscillator is
- (a) an amplifier with feedback
  - (b) a convertor of ac to dc energy
  - (c) nothing but an amplifier
  - (d) an amplifier without feedback
- 9.10 In a Colpitt's oscillator circuit
- (a) capacitive feedback is used
  - (b) tapped coil is used
  - (c) no tuned LC circuit is used
  - (d) no capacitor is used
- 9.11 Since the input impedance of an ideal operational amplifier is infinite,
- (a) its input current is zero
  - (b) its output resistance is high
  - (c) its output voltage becomes independent of load resistance
  - (d) it becomes a current controlled device

9.12 The following arrangement performs the logic function of \_\_\_\_\_ gate

- (a) AND
- (b) OR
- (c) NAND
- (d) EXOR

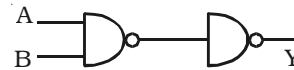

9.13 If the output (Y) of the following circuit is 1, the inputs A B C must be

- (a) 0 1 0
- (b) 1 0 0
- (c) 1 0 1
- (d) 1 1 0

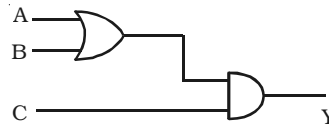

9.14 According to the laws of Boolean algebra, the expression  $(A + AB)$  is equal to

- (a) A
- (b) AB
- (c) B
- (d)  $\bar{A}$

9.15 The Boolean expression  $\overline{ABC}$  can be simplified as

- (a)  $AB + \bar{C}$
- (b)  $\bar{A} \cdot \bar{B} \cdot \bar{C}$
- (c)  $AB + BC + CA$
- (d)  $\bar{A} + \bar{B} + \bar{C}$

- 9.16 Describe the valence band, conduction band and forbidden energy gap with the help of energy level diagram.
- 9.17 Describe the energy band structure of insulator, semiconductor and conductor.
- 9.18 What do you understand by intrinsic and extrinsic semiconductor?
- 9.19 What is rectification?
- 9.20 Explain the working of a half wave diode rectifier.
- 9.21 Explain the working of bridge rectifier.
- 9.22 What is zener breakdown?
- 9.23 Describe the construction of Zener diode.
- 9.24 Explain with necessary circuit how zener diode can be used as a voltage regulator.
- 9.25 Describe the working of PNP and NPN transistors.
- 9.26 Deduce the relation between  $\alpha$  and  $\beta$  of a transistor.
- 9.27 Explain an experiment to determine the characteristics of a transistor in CE configuration. Explain how the transistor parameters can be evaluated.
- 9.28 Why is a transistor called as current amplification device?
- 9.29 Why CE configuration is preferred over CB configuration for operating transistor as an amplifier?
- 9.30 Describe the working of a transistor amplifier.
- 9.31 Define bandwidth of an amplifier.
- 9.32 What is meant by feedback? Name the two types of feedback.
- 9.33 Derive an expression for voltage gain of an amplifier with negative feedback.
- 9.34 What are the advantages of negative feedback?
- 9.35 Give the Barkhausen criteria for oscillations.
- 9.36 Sketch the circuit of Colpitt's oscillator. Explain its working.
- 9.37 Give the function of 'OR' and 'NAND' gates.
- 9.38 What are universal gates? Why are they called so?
- 9.39 What is an EXOR gate? Give the Boolean expression for the EXOR operation.

- 9.40 State and prove DeMorgan's theorems.
- 9.41 What is an integrated circuit?
- 9.42 Identify the analog and digital signals from the following.  
(i) square wave, (ii) sine wave
- 9.43 Differentiate between linear ICs and digital ICs.
- 9.44 Describe an operational amplifier. Explain its action as (i) inverting amplifier and (ii) noninverting amplifier.
- 9.45 Explain the term virtual ground of an operational amplifier.
- 9.46 Give the important parameters of an operational amplifier.
- 9.47 Explain how operational amplifier is used as a summer.
- 9.48 Describe the action of an operational amplifier as difference amplifier.
- 9.49 Explain how multimeter is used as ohm meter.

**Problems**

- 9.50 The base current of the transistor is  $50 \mu\text{A}$  and collector current is  $25 \text{ mA}$ . Determine the values of  $\beta$  and  $\alpha$ .

- 9.51 Find the voltage at the point B in the figure (Silicon diode is used).

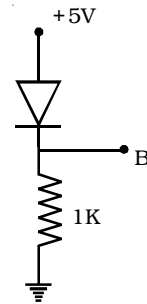

- 9.52 The gain of the amplifier is 100. If 5% of the output voltage is fed back into the input through a negative feed back network. Find out the voltage gain after feed back.
- 9.53 Determine the frequency of oscillations in a Colpitt's oscillator if  $C_1 = 0.01 \mu\text{F}$ ,  $C_2 = 0.03 \mu\text{F}$  and  $L = 100 \text{ mH}$ .
- 9.54 If the two waveforms shown in figure are applied to the OR gate. What is the resulting output wave form?

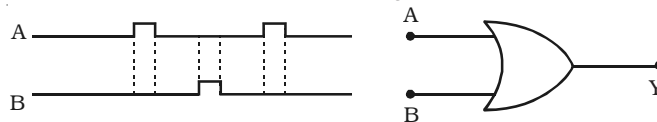

9.55 What is the Boolean expression for the logic diagram shown in figure. Evaluate its output if  $A = 1$ ,  $B = 1$  and  $C = 1$ .

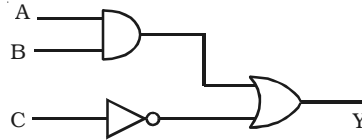

9.56 Find the output  $F$  of the logic circuit given below:

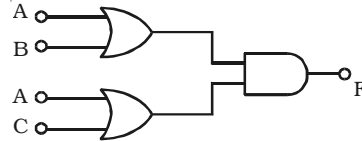

9.57 Give the Boolean equation for the given logic diagram.

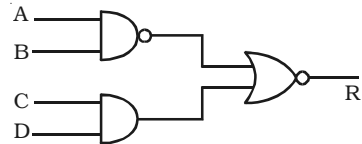

9.58 Prove the following logic expression using the laws and theorems of Boolean algebra.

$$ABC + A\bar{B}C + ABC\bar{C} = A(B+C)$$

9.59 Simplify the following logic expression using the laws and theorems of Boolean algebra.  $Y = A.\bar{B} + AB + BC + CA$

9.60 Find the output of the given circuit.

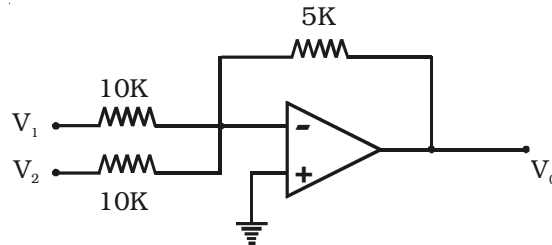



**Answers**

- |                 |                 |                 |                 |                 |
|-----------------|-----------------|-----------------|-----------------|-----------------|
| <b>9.1</b> (a)  | <b>9.2</b> (c)  | <b>9.3</b> (b)  | <b>9.4</b> (d)  | <b>9.5</b> (a)  |
| <b>9.6</b> (d)  | <b>9.7</b> (c)  | <b>9.8</b> (b)  | <b>9.9</b> (a)  | <b>9.10</b> (a) |
| <b>9.11</b> (a) | <b>9.12</b> (a) | <b>9.13</b> (c) | <b>9.14</b> (a) | <b>9.15</b> (d) |

**9.50** 500 ; 0.998

**9.51** + 4.31 V

**9.52** 16.66

**9.53** 5815 Hz

**9.54**

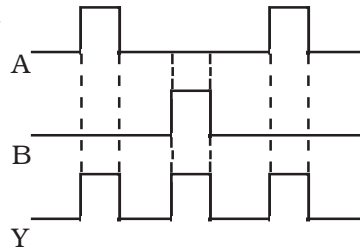

**9.55**  $AB + \bar{C} ; 1$

**9.56**  $F = A + (B.C)$

**9.57**  $R = AB (\bar{C} + \bar{D})$

**9.59**  $A + BC$

**9.60**  $V_o = -\frac{1}{2} (V_1 + V_2)$

## 10. Communication Systems

The present era is the era of 'information and communication revolution'. In electronics, the term 'communication' refers to sending, receiving and processing of information electronically. In 1840's, communication started with telegraphy. Few decades later, telephony was developed followed by radio at the beginning of twentieth century. Radio communication was made possible by the invention of the electronic valves. It subsequently became even more widely used and refined through the invention and use of the transistors, integrated circuits and other semiconductor devices.

More recently, the use of satellites and fiber optics has made communications even more widespread, with an increasing emphasis on computer and other data communications. Radar, telemetry and satellite links play vital role in navigation, defence, scientific research etc. For communication purposes, only a part of the electromagnetic waves like radio waves and microwaves are being used.

### 10.1 Propagation of electromagnetic waves

The propagation of electromagnetic waves depend on the properties of the waves and the environment. Radio waves ordinarily travel in straight lines except where the earth and its atmosphere alter their path. The useful ranges of the electromagnetic spectrum for communication are summarised in Table 10.1.

Radio wave is propagated from the transmitting to the receiving antenna mainly in three different ways depending on the frequency of the wave. They are :

- (i) Ground (surface) wave propagation
- (ii) Space wave propagation
- (iii) Sky wave (or) ionospheric propagation

**Table 10.1 Ranges of electromagnetic spectrum used for communication (NOT FOR EXAMINATION)**

<b>Name</b>	<b>Frequency</b>	<b>Wavelength</b>
Extremely Low Frequencies (ELF)	30-300 Hz	$10^7 - 10^6$ m
Voice Frequencies (VF)	300-3000 Hz	$10^6 - 10^5$ m
Very Low Frequencies (VLF)	3-30 kHz	$10^5 - 10^4$ m
Low Frequencies (LF)	30-300 kHz	$10^4 - 10^3$ m
Medium Frequencies (MF)	300 kHz – 3 MHz	$10^3 - 10^2$ m
High Frequencies (HF)	3 – 30 MHz	$10^2 - 10$ m
Very High Frequencies (VHF)	30 – 300 MHz	10 – 1 m
Ultra High Frequencies (UHF)	300 MHz – 3 GHz	$1 - 10^{-1}$ m
Super High Frequencies (SHF)	3 – 30 GHz	$10^{-1} - 10^{-2}$ m
Extremely High Frequencies (EHF)	30 – 300 GHz	$10^{-2} - 10^{-3}$ m

**10.1.1 Ground (surface) wave propagation**

Ground or surface waves are the radio waves which travel along the surface of the earth as shown in Fig 10.1. Ground wave propagation takes place when the transmitting and receiving antennas are close to the ground. Ground wave propagation is of prime importance only for medium and long wave signals. All medium wave signals received during the daytime use surface wave propagation.

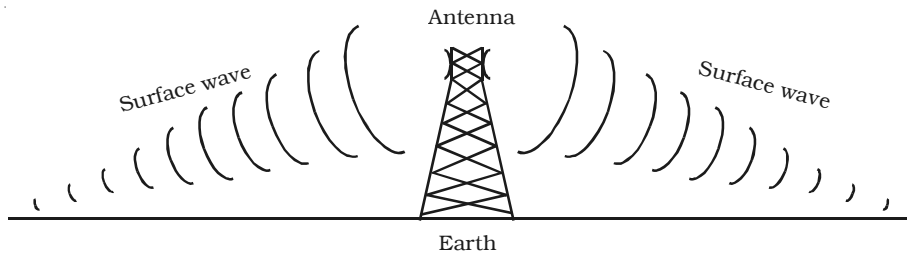

*Fig 10.1 Ground or surface wave radiation from an antenna*

**10.1.2 Space wave propagation**

Radio waves propagated through the troposphere of the Earth are known as space waves. Troposphere is the portion of the Earth's atmosphere which extends upto 15 km from the surface of the Earth. Space wave usually consists of two components as shown in Fig 10.2.

(i) A component which travels straight from the transmitter to the receiver.

(ii) A component which reaches the receiver after reflection from the surface of the Earth.

Space wave propagation is particularly suitable for the waves having frequency above 30 MHz.

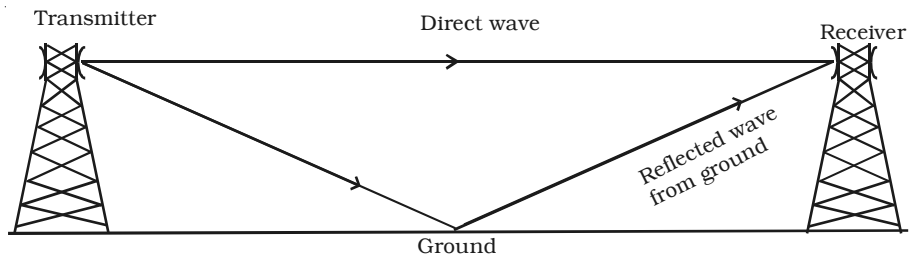

*Fig 10.2 Space wave propagation*

### **10.1.3 Sky wave (or) ionospheric propagation**

The ionosphere is the upper portion of the atmosphere, which absorbs large quantities of radiant energy like ultra violet rays, cosmic rays etc., from the sun, becoming heated and ionised. This ionised region contains free electrons, positive and negative ions.

Radio waves in the short wave band, radiated from an antenna at large angles with ground, travel through the atmosphere and encounters the ionised region in the upper atmosphere. Under favourable circumstances, the radiowaves get bent downwards due to refraction from the different parts of the ionised region and again reach the earth at a far distant point. Such a radio wave is called the sky wave and such a propagation of radio wave is known as sky wave propagation or ionospheric propagation. Long distance radio communication is thus possible through the sky wave propagation.

#### **Reflection of electromagnetic waves by ionosphere**

The electromagnetic waves entering into the ionosphere, are reflected by the ionosphere. In fact, the actual mechanism involved is refraction. The refractive indices of the various layers in the ionosphere do not remain constant and it varies with respect to electron density and the frequency of the incident wave. As the ionisation density increases for a wave approaching the given layer at an angle, the refractive index of the layer is reduced. Hence, the incident wave is

gradually bent farther and farther away from the normal as shown in Fig 10.3 until some point. When the electron density is large, the angle of refraction becomes  $90^\circ$  and the wave, then travel towards the Earth.

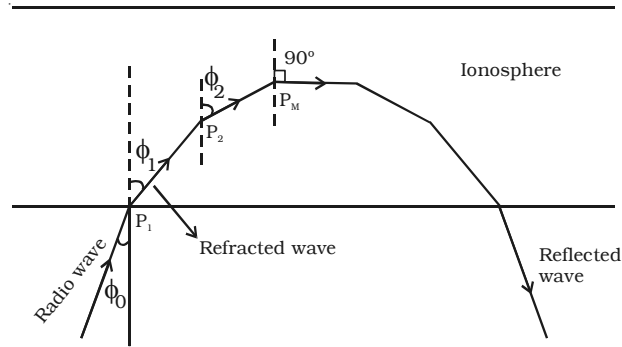

Fig 10.3 Refraction of the radio wave in ionosphere

**Skip distance and skip zone**

In the skywave propagation, for a fixed frequency, the shortest distance between the point of transmission and the point of reception along the surface is known as the *skip distance*.

When the angle of incidence is large for the ray  $R_1$  as shown in Fig. 10.4, the sky wave returns to the ground at a long distance from

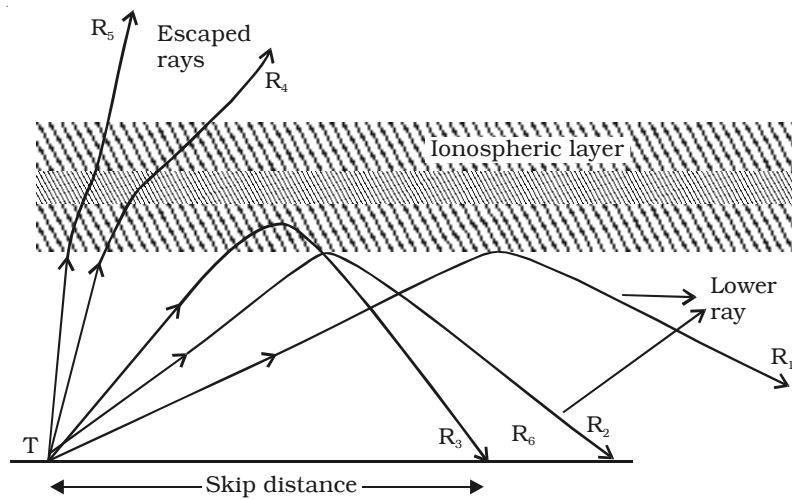

Fig 10.4 Travel of radio waves at different angles of incidence

the transmitter. As this angle is slowly reduced, naturally the wave returns closer and closer to the transmitter as shown by the rays  $R_2$  and  $R_3$ . If the angle of incidence is now made significantly less than that of ray  $R_3$ , the ray will be very close to the normal to be returned to the Earth. If the angle of incidence is reduced further, the radio waves penetrate through the layer as shown by the rays  $R_4$  and  $R_5$ . For a particular angle of incidence, the distance between the point of transmission and the point of reception is minimum. The minimum distance between the transmitter and the ray like  $R_3$  which strikes the Earth is called as the skip distance.

As we move away from the transmitter, the ground wave becomes lesser and lesser significant. A stage comes when there is no reception due to the ground waves. This point lies somewhere in the skip distance. The region between the point where there is no reception of ground waves and the point where the sky wave is received first is known as skip zone. In the *skip zone*, there is no reception at all.

## **10.2 Modulation**

In radio broadcasting, it is necessary to send audio frequency signal (eg. music, speech etc.) from a broadcasting station over great distances to a receiver. The music, speech etc., are converted into audio signals using a microphone. The energy of a wave increases with frequency. So, the audio frequency (20 – 20000 Hz) is not having large amount of energy and cannot be sent over long distances. The radiation of electrical energy is practicable only at high frequencies e.g. above 20 kHz. The high frequency signals can be sent through thousands of kilometres with comparatively small power.

Therefore, if audio signal is to be transmitted properly, the audio signal must be superimposed on high frequency wave called carrier. The resultant waves are known as modulated waves and this process is called as modulation. This high frequency wave (Radio frequency wave) is transmitted in space through antenna. At the receiver end, the audio signal is extracted from the modulated wave by the process called demodulation. The audio signal is then amplified and reproduced into sound by the loud speaker.

A high frequency radio wave is used to carry the audio signal. On adding the audio signal to carrier, any one of the characteristics namely amplitude or frequency or phase of the carrier wave is changed in accordance with the intensity of the audio signal. This process is known as modulation and may be defined as the process of changing amplitude or frequency or phase of the carrier wave in accordance with the intensity of the signal. Some of the modulation process namely, (i) amplitude modulation, (ii) frequency modulation and (iii) phase modulation are discussed.

### 10.2.1 Amplitude modulation (AM)

When the amplitude of high frequency carrier wave is changed in accordance with the intensity of the signal, the process is called *amplitude modulation*.

In the amplitude modulation, only the amplitude of the carrier wave is changed. The frequency and the phase of the carrier wave remains constant. Fig 10.5 shows the principle of amplitude modulation.

Fig 10.5a shows the audio electrical signal of frequency  $f_s$ . Fig 10.5b shows a carrier wave of constant amplitude with frequency  $f_c$ . Fig 10.5c is the amplitude modulated wave. It is to be noted that the amplitudes of both positive and negative half cycles of carrier wave are changed in accordance with the signal. Thus the amplitude of the modulated wave possesses the frequency of the audio signal wave.

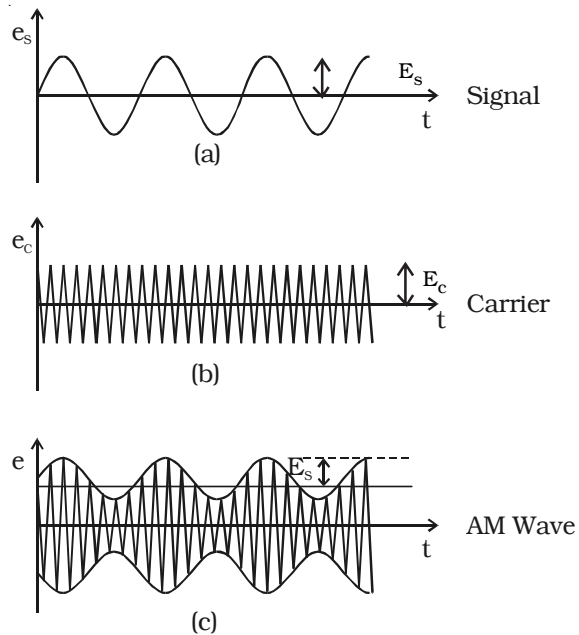

Fig 10.5 Amplitude modulation

**Modulation factor**

An important term in amplitude modulation is modulation factor which describes the extent to which the amplitude of the carrier wave is changed by the audio signal. It is defined as the ratio of the change of amplitude in carrier wave after modulation to the amplitude of the unmodulated carrier wave.

i.e. modulation factor,  $m = \frac{\text{Amplitude change of carrier wave after modulation}}{\text{Amplitude of carrier wave before modulation}}$

$$m = \frac{\text{Signal amplitude}}{\text{Carrier amplitude}}$$

Modulation factor determines the strength and quality of the transmitted signal. When the modulation factor  $m < 1$ , the amount of carrier amplitude variation is small (Fig 10.6a). Consequently, the audio signal being transmitted will not be very strong. When the modulation factor  $m > 1$ , distortion is produced in the transmitted wave as shown in Fig 10.6 b. Hence, the signal wave is not exactly reproduced. For effective modulation, the degree of modulation should never exceed 100 %.

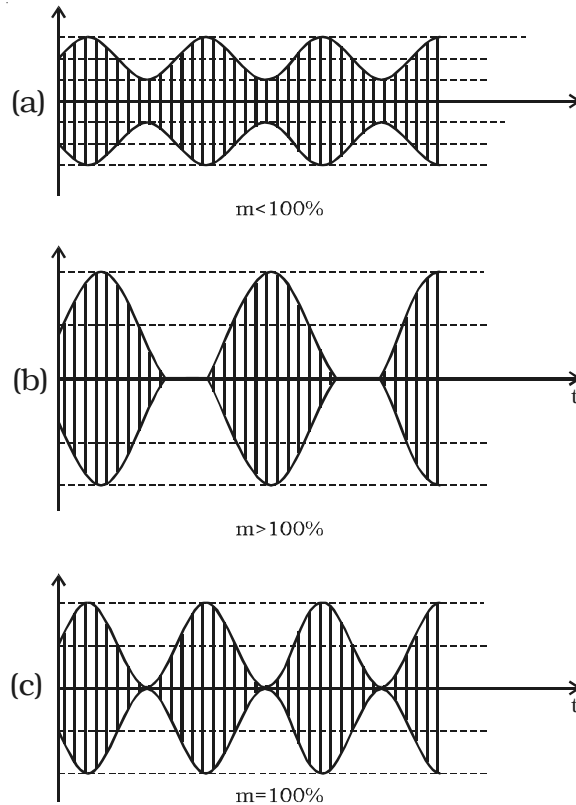

Fig 10.6 Amplitude modulated waves for different modulation factors



### **Analysis of amplitude modulated wave**

A carrier wave may be represented as,

$$e_c = E_c \cos \omega_c t \quad \dots (1)$$

where  $e_c$ ,  $E_c$  and  $\omega_c$  represent the instantaneous voltage, amplitude and angular frequency of the carrier wave respectively.

In amplitude modulation, the amplitude  $E_c$  of the carrier wave is varied in accordance with the intensity of the audio signal as shown in Fig 10.5. The modulating signal may be represented as,

$$e_s = E_s \cos \omega_s t \quad \dots (2)$$

where  $e_s$ ,  $E_s$  and  $\omega_s$  represent instantaneous voltage, amplitude and angular frequency of the signal respectively.

Amplitude modulated wave is obtained by varying  $E_c$  of equation (1) in accordance with  $E_s$ . Thus, amplitude modulated wave is,

$$e = (E_c + E_s \cos \omega_s t) \cos \omega_c t$$

$$e = E_c \left[ 1 + \left( \frac{E_s}{E_c} \right) \cos \omega_s t \right] \cos \omega_c t = E_c [1 + m \cos \omega_s t] \cos \omega_c t$$

where  $m$  is the modulation factor which is equal to  $\frac{E_s}{E_c}$ .

$$\therefore e = E_c \cos \omega_c t + m E_c \cos \omega_c t \cdot \cos \omega_s t \quad \dots(3)$$

$$= E_c \cos \omega_c t + \frac{m E_c}{2} [2 \cos \omega_c t \cos \omega_s t]$$

$$= E_c \cos \omega_c t + \frac{m E_c}{2} [\cos (\omega_c + \omega_s) t + \cos (\omega_c - \omega_s) t]$$

$$= E_c \cos \omega_c t + \frac{m E_c}{2} \cos (\omega_c + \omega_s) t + \frac{m E_c}{2} \cos (\omega_c - \omega_s) t \quad \dots(4)$$

This expression shows that the modulated wave contains three components:

- (i)  $E_c \cos \omega_c t$  : This component is same as the carrier wave.
- (ii)  $\frac{m E_c}{2} \cos (\omega_c + \omega_s) t$  : This component has a frequency greater than that of the carrier and is called as the Upper Side Band (USB).
- (iii)  $\frac{m E_c}{2} \cos (\omega_c - \omega_s) t$  : This component has a frequency lesser than that of the carrier and is called as the Lower Side Band (LSB).

### Frequency spectrum

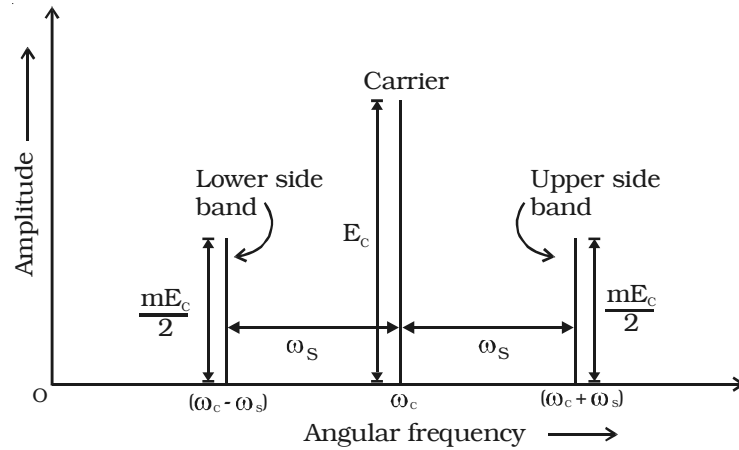

Fig 10.7 Plot of frequency spectrum of amplitude modulated voltage.

The lower side band term and upper side band term are located in the frequency spectrum on either side of the carrier at a frequency interval of  $\omega_s$  as shown in Fig 10.7. The magnitude of both the upper and lower side bands is  $\frac{m}{2}$  times the carrier amplitude  $E_c$ . If the modulation factor  $m$  is equal to unity, then each side band has amplitude equal to half of the carrier amplitude.

### Bandwidth

In an AM wave, the bandwidth is from  $(\omega_c - \omega_s)$  to  $(\omega_c + \omega_s)$  i.e twice the signal frequency. In the preceding section, it is assumed that the modulating signal is composed of one frequency component only. However, in a broadcasting station, the modulating signal is the human voice or music which contains waves with a frequency range of 300 – 3000 Hz.

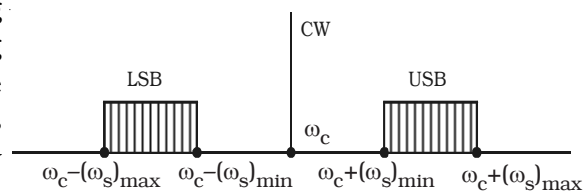

Fig 10.8 Channel width

Each of these waves has its own side bands. The upper side band (USB), in fact, contains all sum components of the signal and carrier frequency whereas lower side band (LSB) contains the difference components, as shown in Fig 10.8.

The channel width is given by the difference between extreme frequencies i.e. between maximum frequency of USB and minimum frequency of LSB.

$$\begin{aligned}\therefore \text{Channel width} &= 2 \times \text{maximum frequency of the modulating signal} \\ &= 2 \times (f_s)_{\max}\end{aligned}$$

### **Advantages**

- (i) Easy transmission and reception
- (ii) Lesser bandwidth requirements
- (iii) Low cost

### **Limitations**

(i) *Noisy reception* : In an AM wave, the signal appears in the amplitude variations of the carrier. Practically, all the natural and man made noises consists of electrical amplitude disturbances. As a radio receiver cannot distinguish between amplitude variation that represent noise and those that contain the desired signal, the reception is generally noisy.

(ii) *Low efficiency* : In AM, useful power is available in the side bands, since they contain signals. The sideband power for an AM wave is low. Hence the efficiency of AM is low.

(iii) *Small operating range* : Due to low efficiency of amplitude modulation, transmitters employing this method have a small operating range i.e. the messages cannot be transmitted over long distances.

### **10.2.2 Frequency modulation (FM)**

When the frequency of carrier wave is changed in accordance with the intensity of the signal, the process is called frequency modulation.

In frequency modulation, the amplitude and phase of the carrier wave remains constant. Only, the frequency of the carrier wave is changed in accordance with the signal.

The frequency variation of the carrier wave depends upon the instantaneous amplitude of the signal as shown in Fig 10.9a. When the signal voltage is zero at A,C,E and G, the carrier frequency is unchanged. When the signal approaches its positive peaks at B and F, the carrier frequency is increased to maximum as shown by closely spaced cycles in Fig 10.9c. But during the negative peak of signal as at D, the carrier frequency is reduced to minimum as shown by widely

spaced cycles in Fig. 10.9c. The louder signal causes greater frequency change in modulated carrier as indicated by increased bunching and spreading of the waves as compared with relatively weaker signal.

The frequency of an FM transmitter without signal input is called the *resting frequency or centre frequency* ( $f_o$ ) and this is the allotted frequency of the transmitter. When the signal is applied, the carrier frequency deviates up and down from its resting value  $f_o$ .

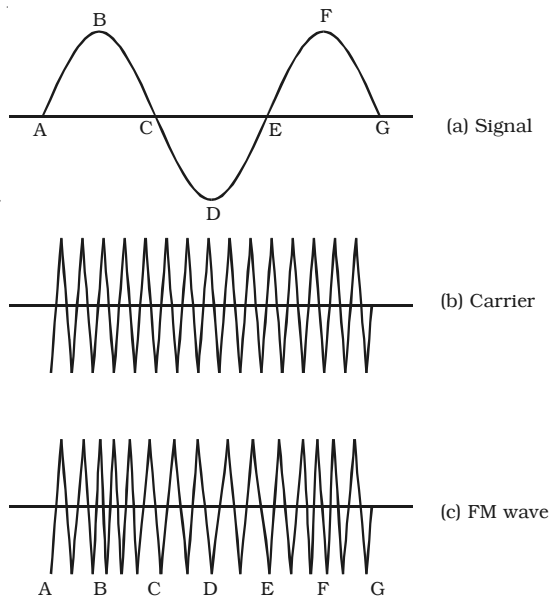

Fig 10.9 Frequency Modulation

The change or shift either above or below the resting frequency is called frequency deviation ( $\Delta f$ ). The total variation in frequency from the lowest to the highest is called *carrier swing* (CS). Hence,

$$\begin{aligned} \text{Carrier swing} &= 2 \times \text{frequency deviation} \\ &= 2 \times \Delta f \end{aligned}$$

For the purposes of FM broadcasts, it has been internationally agreed to restrict maximum deviation to 75 kHz on each side of the centre frequency for sounds of maximum loudness.

### **Advantages**

- (i) It gives noiseless reception. Noise is a form of amplitude variation and a FM receiver will reject such noise signals.
- (ii) The operating range is quite large.
- (iii) The efficiency of transmission is very high.

### **Disadvantages**

- (i) A much wider channel is required by FM.
- (ii) FM transmitting and receiving equipments tends to be more complex.

### **10.2.3 Phase modulation (PM)**

In phase modulation, the phase of the carrier wave is varied in accordance with the amplitude of the modulating signal and the rate of variation is proportional to the signal frequency. The waveform of the phase modulated wave is similar to that of FM wave. The phase modulation, generally uses a smaller bandwidth than FM. In other words, more information can be sent in a given bandwidth in phase modulation. Therefore, phase modulation facilitates highest transmission speeds on a given bandwidth. In phase modulation also, there is a frequency shift in the carrier wave frequency. The frequency shift depends on (i) amplitude of the modulating signal and (ii) the frequency of the signal. One great advantage of the phase modulation lies in the fact that the FM signal produced from PM signal is very stable. Also, the centre frequency called resting frequency is extremely stable.

### **10.3 Antennas**

In radio, TV, Radar and mobile phone communication systems, an electromagnetic wave travels from the transmitter to the receiver through space and antennas are required at both ends for the purpose of coupling the transmitter and the receiver to the space link.

An antenna is a long conductor (wire and rod) that acts as a conversion device. It converts an electrical signal into electromagnetic energy when used as a transmitting antenna. In receiving antenna, the electromagnetic energy is converted into an electrical signal.

An antenna is characterised by an important parameter, directivity. Directivity is the ability of the antenna to concentrate the electromagnetic waves in the most desired directions (during transmission) or to have maximum reception from most preferred directions (during reception).

### **10.4 Radio transmission and reception**

#### **10.4.1 Radio transmission**

After modulation, the radio waves are transmitted over long distances with the help of electronic circuits called transmitters. The simplest form of transmitter consists of an oscillator, generating a high frequency wave connected to an antenna.

In this section, we shall discuss the amplitude and frequency modulated transmitters.

**Amplitude modulated (AM) transmitter**

Fig 10.10 gives the block diagram of amplitude modulated radio transmitter. It consists of two sections (i) Audio frequency (AF) section and (ii) Radio frequency (RF) section.

**AF section**

The AF section of the transmitter generates the modulating wave (signal). The conversion of sound energy into electrical energy is performed by the microphone.

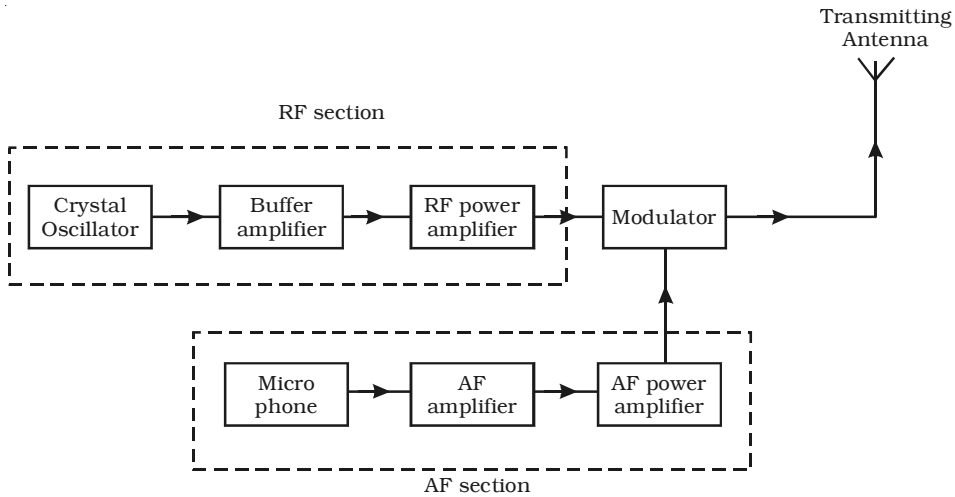

Fig 10.10 Functional block diagram of amplitude modulated radio transmitter

The electrical energy available from the microphone is very low. Hence, it is amplified through an amplifier. The output from the AF amplifier is fed to the AF power amplifier. The power amplifier provides the required audio frequency power. The output of the AF power amplifier is given to the modulator. A modulator is an electronic circuit with transistor and passive components, which performs the process of modulation.

**RF section**

In the RF section, the high frequency carrier wave is generated by a crystal controlled oscillator. The output of the crystal controlled

oscillator is power amplified by RF power amplifier. The buffer\* isolates the RF power amplifier from the oscillator. This arrangement keeps the frequency of the crystal controlled oscillator as a constant. In the modulator the RF wave and modulating AF signal are mixed to produce the amplitude modulated wave. The output of this section is fed to the antenna for transmission.

### **Frequency modulated (FM) transmitter**

Frequency modulated systems are operated usually at a frequency above 40 MHz. Frequency modulated broadcasting is done in television sound, mobile radio etc. The functional block diagram of a FM transmitter employing phase modulation is shown in Fig 10.11. The phase modulation is essentially a frequency modulation.

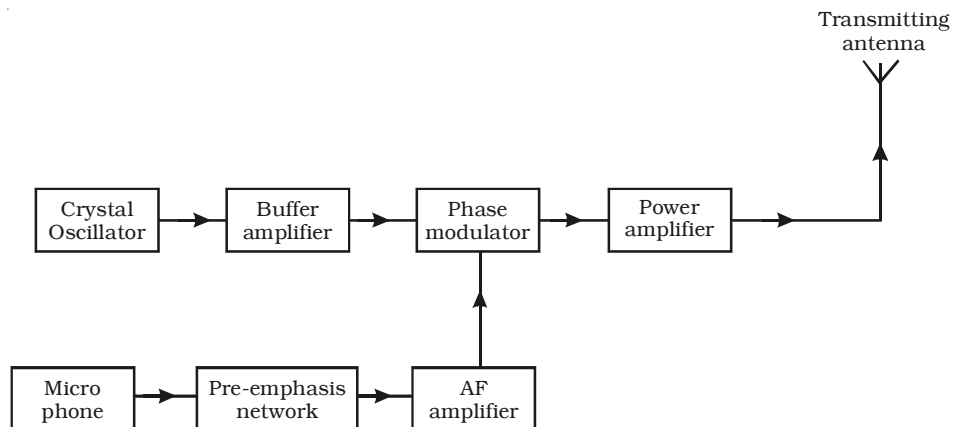

*Fig 10.11 FM transmitter*

It consists of a crystal oscillator, which produces the carrier wave and the output of this is fed into the phase modulator. The buffer is a low frequency amplifier which isolates the crystal oscillator from the phase modulator.

The modulating signal is produced from a microphone. Since this AF modulating signal has uneven power, it is fed into a network called pre-emphasis network, where all the frequencies in the modulating signal are made to have equal power. The output of the pre-emphasis network is then amplified and sent for phase modulation. The

---

\* Buffer is an electronic circuit, used for the purpose of providing isolation between two other stages. This also prevents the impedance change between the two stages.

modulated output is then power amplified using a power amplifier and then fed into the transmitting antenna for transmission.

#### **10.4.2 Radio reception**

A radio receiver has the function of selecting the desired signal from all other unwanted signals, amplifying, demodulating it and finally producing it in the desired manner.

##### **A simple (or) straight radio receiver**

The functional block diagram of a simple radio receiver is shown in Fig 10.12. The receiving antenna receives the radiowaves from different broadcasting stations. The desired radiowave is selected by the radio frequency amplifier, which employs a tuned parallel circuit. The tuned RF amplifier amplifies this selected radiowave. The amplified radiowave is fed to the detector circuit which consists of a PN diode. This circuit extracts the audio signal from the radiowave. The output of the detector is the audio signal, which is amplified by one or more stages of audio amplification. The amplified audio signal is given to the loud speaker for sound reproduction.

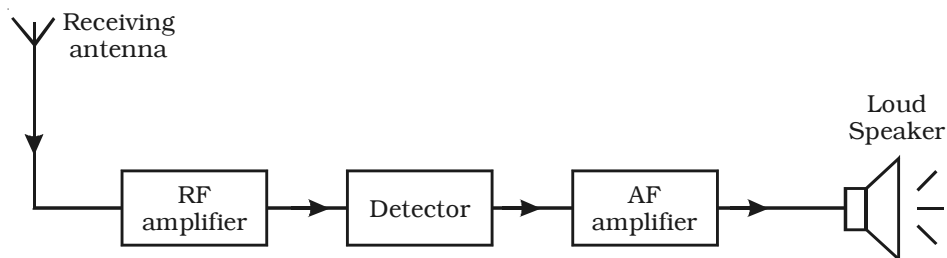

Fig 10.12 Simple radio receiver

##### **Disadvantages**

Simple radio receiver circuit has

- (i) poor sensitivity\* and
- (ii) poor selectivity\*\*

---

\* Sensitivity : the ability to amplify the weak signals

\*\* Selectivity : the ability to select a particular wanted signal only and rejecting the unwanted signals



### **Superheterodyne AM receiver**

The shortcomings of straight radio receiver were overcome by the invention of superheterodyne receiver. All the modern receivers utilise the superheterodyne circuit.

The functional block diagram of AM receiving system of superheterodyne type is shown in Fig 10.13.

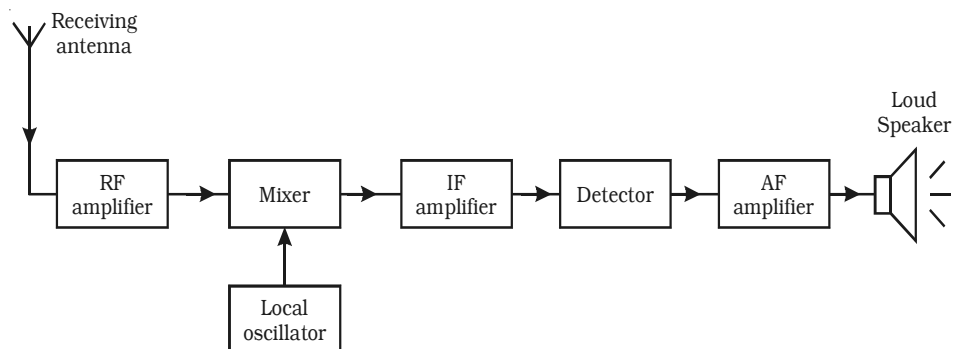

*Fig 10.13 Superhet AM receiver*

#### **(i) RF amplifier**

The RF amplifier uses a tuned parallel circuit. The radiowaves from various broadcasting stations are intercepted by the receiving antenna and are coupled to this stage. This stage selects the desired radiowave and enhances the strength of the wave to the desired level.

#### **(ii) Mixer and local oscillator**

The amplified output of RF amplifier is fed to the mixer stage, where it is combined with the output of a local oscillator. The two frequencies beat together and produce an intermediate frequency (IF). The intermediate frequency is the difference between oscillator frequency and radio frequency. The output of this section is always equal to the intermediate frequency 455 kHz.

For example, if 600 kHz station is tuned, then local oscillator will produce a frequency of 1055 kHz and consequently the output from the mixer will have frequency of 455 kHz. By achieving this fixed intermediate frequency, the amplifier circuit in such receivers can be made to operate with maximum stability, selectivity and sensitivity.

**(iii) IF amplifier**

The output of the mixer circuit is fed to the tuned IF amplifier. This amplifier is tuned to one frequency (i.e. 455 KHz ) and is amplified.

**(iv) Detector**

The output from the IF amplifier is coupled with input of a detector. The audio signals are extracted from the IF output. Usually a diode detector circuit is used because of its low distortion and excellent audio fidelity (reproducing ability).

**(v) AF amplifier**

The detected AF signal is usually weak and so it is further amplified by the AF amplifier. Then, the output signal from the amplifier is fed to the loud speaker, which converts the audio signal into sound waves corresponding to the original sound at the broadcasting station.

**FM Superheterodyne receiver**

An FM receiver is a superheterodyne type like a typical AM receiver. The functional block diagram of an FM receiver is shown in Fig 10.14.

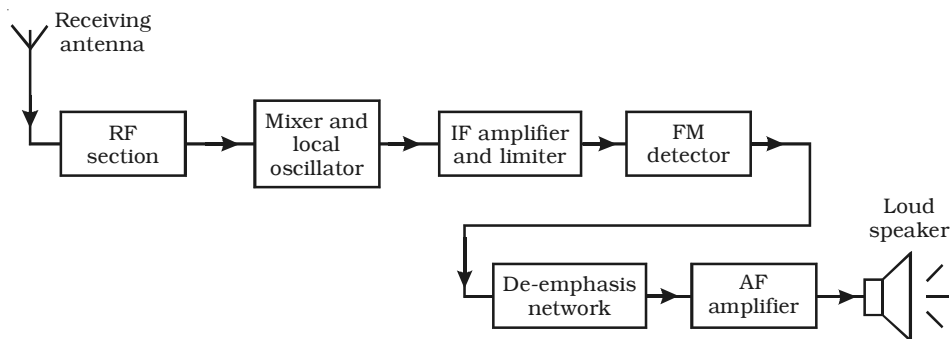

Fig 10.14 FM receiver

The RF section selects the incoming modulated signals and is amplified. It is then fed into the mixer and local oscillator. Here the frequency of the modulated signal is changed to intermediate frequency. For FM receivers, this IF is 10.7 MHz. The intermediate frequency wave is amplified using IF amplifier and then its amplitude is

maintained constant using a limiter\*. The output of this section is applied to the FM detector which demodulates the modulated wave. The AF signal from the FM detector is then passed on through a de-emphasis network, where the various frequencies attain their original power distribution. Finally it is fed into the loud speaker after performing AF amplification.

## **10.5 Television**

Television is one of the marvels that has been achieved in the field of electronics. “Television” literally means “*seeing at a distance.*” The principle of television broadcasting is essentially the same as that of sound broadcasting. In sound broadcasting, sound waves are converted into equivalent electrical signals using microphone, which are modulated and transmitted. In picture broadcast (television), the bright and dark spots of a scene are systematically scanned to produce equivalent electrical signals. These picture signals are modulated and are then transmitted. At the receiving end, the picture signals are extracted from the modulated wave. These are made to reproduce the bright and dark spots of the original scene on the fluorescent screen of a cathode ray tube called viewing tube. The sound associated with the scene is transmitted simultaneously to provide a complete picture and sound reproduction at the receiver. Although the end result required is a motion picture, television is basically a system for reproducing a still picture. Many of these are shown one after the other in rapid sequence during each second, to give the illusion of motion. Therefore, the first requirement of the television system is that it should be capable of transmitting and receiving a simple still picture. Usually sound signals are frequency modulated, while picture signals are amplitude modulated.

### **10.5.1 Vidicon camera tube**

Vidicon camera is a television camera which converts the light energy into electrical energy. It functions on the principle of photo conductivity, where the resistance of target material decreases when exposed to light.

---

*\*A limiter is a device that prevents a signal voltage from exceeding a certain peak value. Limiters are used in FM receivers for the purpose of reducing the response to variations in signal amplitude.*

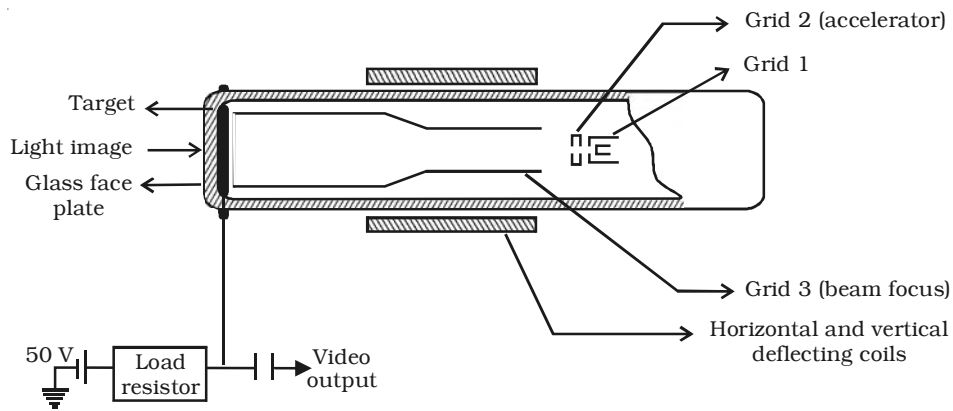

Fig 10.15 Vidicon camera tube

### Construction

The Vidicon consists of a glass envelope with an optically flat face plate (Fig 10.15). A photosensitive, target plate is available on the inner side of the face plate. The target plate has two layers. To the front, facing the face plate, is a thin layer of tin oxide. This is transparent to light but electrically conductive. The other side of the target plate is coated with a semiconductor, photosensitive antimony trisulphide. The tin oxide layer is connected to a power supply of 50V.

Grid-1 is the electron gun, consisting a cathode and a control grid. The emitted electrons are accelerated by Grid-2. The accelerated electrons are focussed on the photo conductive layer by Grid-3. Vertical and Horizontal deflecting coils, placed around the tube are used to deflect the electron beam for scanning the target.

### Working

The light from a scene is focussed on the target. Light passes through the face plate and tin oxide, incident on the photo conductive layer. Due to the variations in the light intensity of the scene, the resistance of the photo conductive layer varies. The emitted electrons from antimony trisulphide reach the positive tin oxide layer. So, each point on the photo conductive layer acquires positive charge. Hence, a charge image that corresponds to the incident optical image is produced. As the electron beam from the gun is incident on the charge image, drop in voltage takes place. As a result, a varying current is produced. This current produces the video-signal output of the camera.

### 10.5.2 Scanning and synchronising

A still picture is fundamentally an arrangement of many dark and light areas. Each small area of light or shade is called a picture element. All the elements contain the visual information in the scene. If they are transmitted and reproduced in the same degree of light or shade as original and in proper position, the picture will be reproduced.

In order to produce video signal for all the elements in the picture, it is scanned by the electron beam, one element at a time, in sequential order. The scanning is done in the same way as a written page is read to cover all the words in one line and all lines on the page. Hence, scanning is the process by which an electron beam spot is made to move across a rectangular area, so as to cover it completely. This rectangular area may be the target surface in a television camera or the screen of a picture tube in a television receiver.

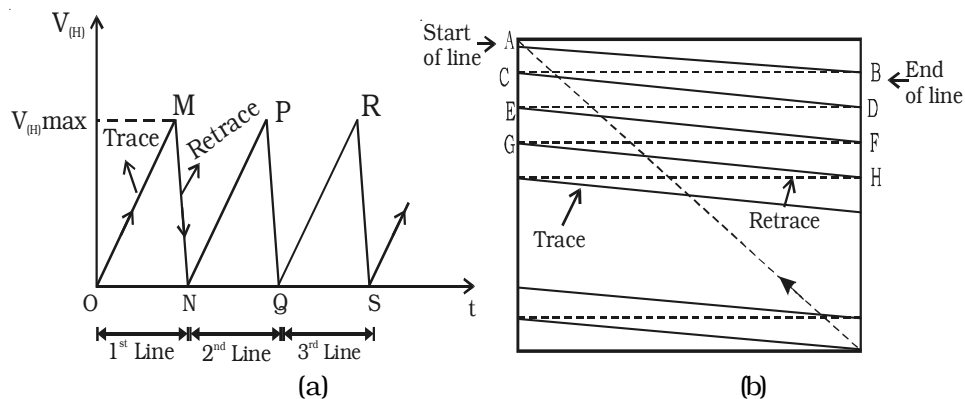

Fig 10.16 Simple scanning process

The scene is scanned rapidly both in the horizontal and vertical directions simultaneously. This provides sufficient number of complete pictures or frames per second to give the illusion of continuous motion. In most of the television systems, the frame repetition rate (scanning frequency) is 25 per second.

For scanning the picture elements, saw tooth potentials can be used. Saw tooth potentials are produced by using a unijunction transistor and a R-C network. Saw tooth potentials are applied to horizontal and vertical deflector plates in a TV camera. When the saw

tooth potential is applied to the horizontal plates called line synchronising pulse, the electron beam at A travels along a slanting line AB by the voltage variation of OM and reaches the point B (Fig 10.16a and b). From B, the scanning spot travels along a line BC by the voltage variation MN. In order that no picture should be scanned during the return journey (i.e. the beam from the right horizontal end to the beginning of the next line), a blanking pulse, which is a high negative potential, is applied to the control grid of electron gun during the duration of the return journey. This prevents the emission of electrons from electron gun. Then the electron beam starts to scan the next line and the process gets repeated till the whole picture is scanned. On reaching the right bottom corner, the scanning spot quickly moves up to the top left corner by the application of saw tooth potential to the vertical deflector plates, called frame synchronising pulse. Thus for scanning the picture, the three synchronising pulses are used. These synchronising pulses along with the output of the TV camera are modulated on an ultra high frequency carrier and transmitted. The accompanying sound is frequency modulated and transmitted via the same antenna.

### ***Interlaced scanning***

In India, the frame repetition rate has been standardised at 25 frames per second. This repetition rate is enough to cause an illusion of continuity. But, the brightness of one frame blends (mix) smoothly into the next, through this time when the screen is blanked between successive frames. This results in definite flicker of light, that is very annoying to the observer, when the screen becomes alternatively bright and dark. To eliminate this flicker, each frame is scanned twice.

In this scanning, the total number lines are divided into two groups called fields. During the presentation of the first field, only the odd numbered lines are scanned, while during the second field all the even numbered lines are scanned. Half way along the bottom of the first field, the vertical retrace returns the scanning beam to the top of the image and completes the unfinished lines. (i.e) The remaining even numbered lines are then scanned during second field. This method of scanning is known as interlaced scanning. In the 625 line TV system, for successful interlaced scanning, the 625 lines of each frame or

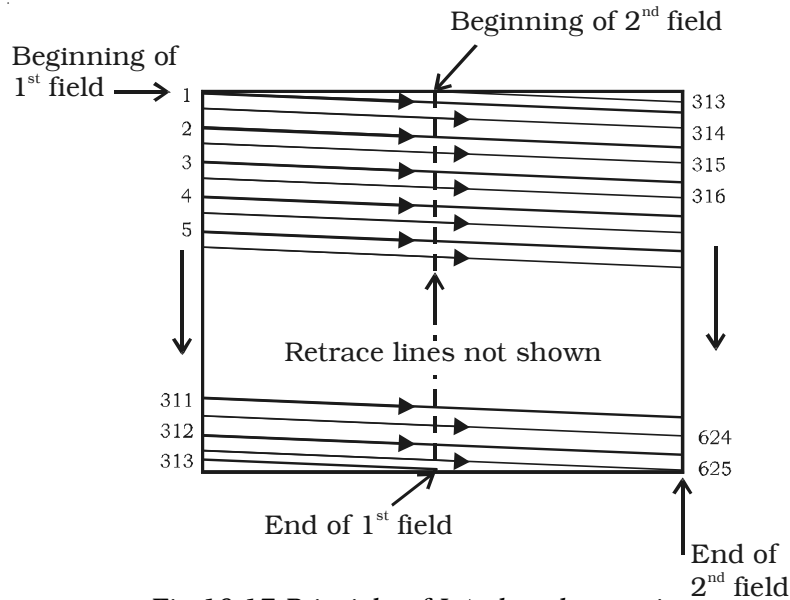

Fig 10.17 Principle of Interlaced scanning

picture are divided into sets of 312.5 lines and each set is scanned alternatively to cover the entire picture area. The principle of interlaced scanning is shown in Fig 10.17.

Hence, with the interlaced scanning the flicker effect is eliminated without increasing the speed of scanning, which in turn does not need any increase in channel bandwidth.

### **Horizontal and vertical scanning frequencies**

The movement of electron beam spot from left to right and back, so as to start a new line in the same direction is termed as horizontal scanning. The horizontal scanning frequency is defined as the number of lines scanned per second. In a 625 line system, transmitting 25 frames per second, the horizontal frequency is  $625 \times 25 = 15,625$  Hz.

Consequently, time taken to scan one line is  $\frac{1}{15,625} = 64 \mu\text{s}$ .

Vertical scanning is the movement of the electron beam spot in the vertical direction. One frame consists of two fields, resulting into 50 fields per second with a vertical field scan time of  $\frac{1}{50} = 20$  ms.

## 10.6 Monochrome picture tube

The picture tube is a special form of cathode ray tube, the face plate of which serves as a screen of the television receiver. The various parts of a monochrome picture tube are shown in Fig 10.18. The cathode ray tube (CRT) is housed in a bell-shaped glass enclosure. A filament heats a cathode that emits electrons. The negatively charged electrons are attracted and accelerated by positive-bias voltages on the elements in an electron gun assembly. The electron gun also focuses the electrons into narrow beam.

A control grid that is made negative with respect to the cathode, controls the intensity of the electron beam and brightness of the spot it makes. The beam is accelerated towards the screen by a very high voltage applied to an internal metallic coating called aquadag. The face or front of the picture tube is coated internally with a phosphor, that glows and produces white light, when it is struck by the electron beam.

Around the neck of the picture tube is a structure of magnetic coils called the deflecting yoke. The horizontal and vertical current linear saw tooth waves generated by the sweep and synchronising circuits are applied to the yoke coils. This produces the magnetic field inside the tube that influence the position of the electron beam. When the electrons flow, a magnetic field is produced around the conductor through which the current flows. In a CRT, the electron beam is moved or deflected by the magnetic field produced by the deflection coils in the yoke. Thus the electron beam is swept across the face of the picture tube.

As the beam is being swept across the face of the tube to trace out the scene, the intensity of the electron beam is varied by the luminance or Y signal. The Y signal is applied to the cathode or in some cases to the control grid. The control grid is an element in the electron gun, that is negatively biased with respect to the cathode. By varying the grid voltage, the beam can be made weaker or stronger, thereby varying the intensity of the light spot produced by the beam, when it strikes the phosphor. Any shade of grey from white to black can be reproduced.



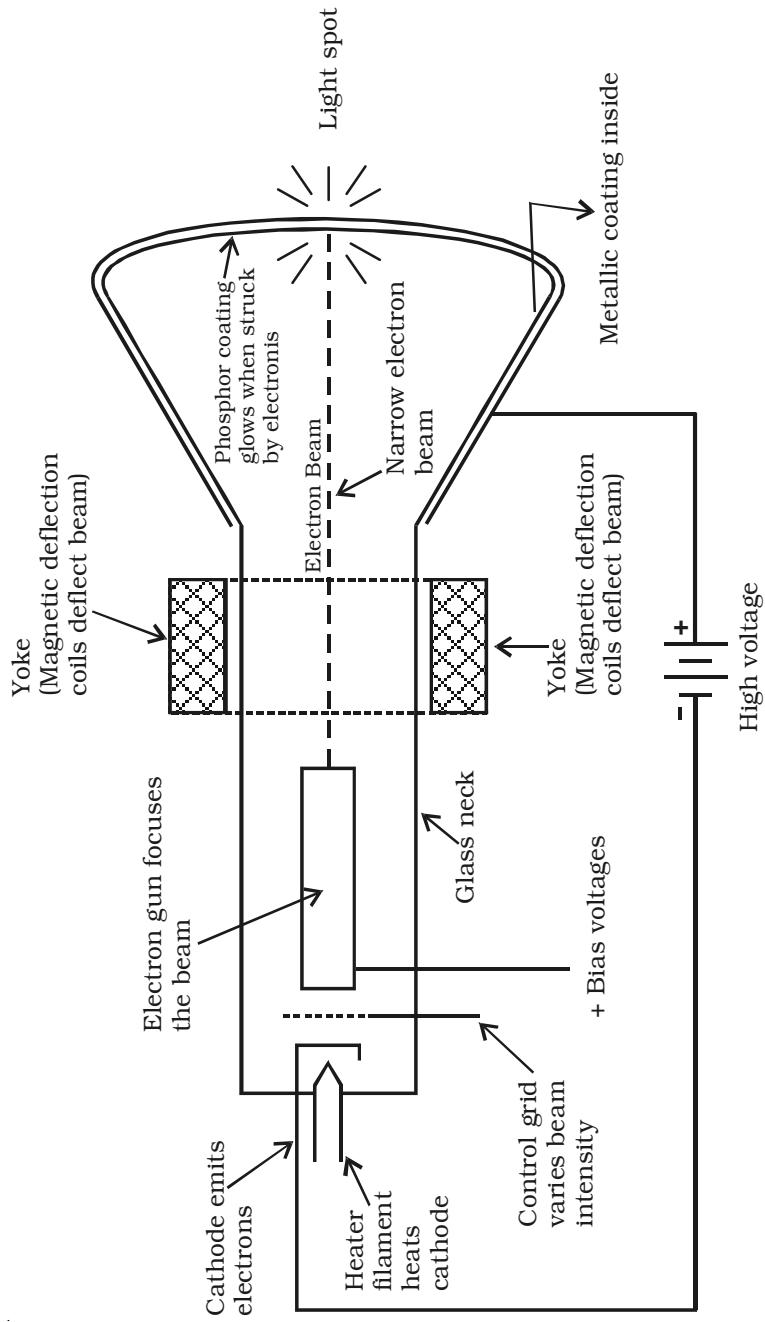
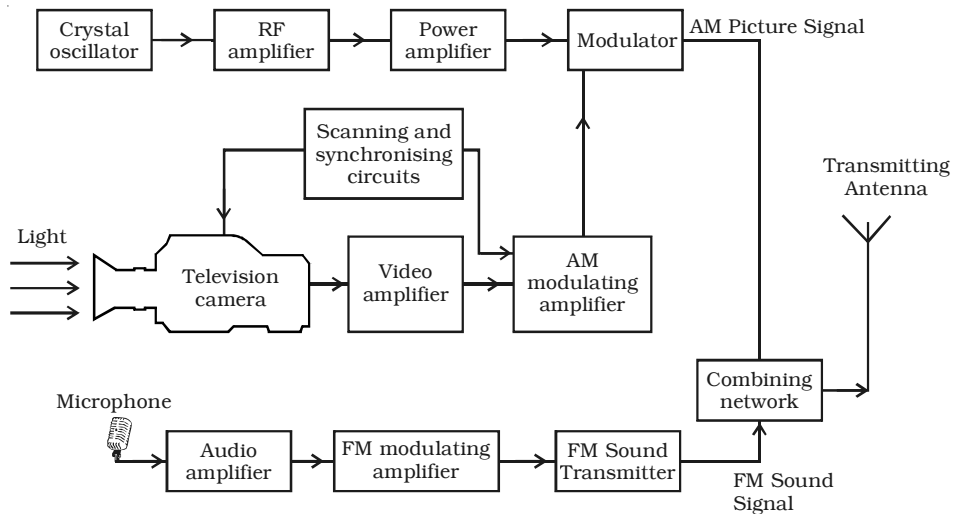

Fig 10.18 Monochrome picture tube

### 10.7 Monochrome TV transmission

An over simplified block diagram of a monochrome TV transmitter is shown in Fig 10.19. The functional block diagram can be broadly divided into two sections, viz. an amplitude modulated transmitter and a frequency modulated transmitter. Former is used for video modulation, whereas latter is used for audio modulation.



*Fig 10.19 Functional block diagram of a monochrome television transmitter*

The synchronising and scanning circuits produce sets of pulses for providing synchronising pulses for proper functioning of the TV system. This timing unit contains number of wave generating and wave shaping circuits. The repetition rate of its various output pulse trains is controlled by a frequency stabilised master oscillator.

The output signal of a camera tube corresponding to the image to be televised is amplified through a number of video amplifier stages.

The image signals together with the synchronising and blanking pulses are raised to a level suitable for modulating the RF carrier wave generated in the RF channel. The allotted picture carrier frequency is generated by the crystal controlled oscillator. The continuous wave output is given large amplification before feeding to the power amplifier. In the modulator, its amplitude is made to vary in accordance with the modulating signal received from the modulating amplifier.

The microphone converts the sound associated with the picture being televised into proportionate electrical signal. The audio signal from the microphone after amplification is frequency modulated, employing the assigned carrier frequency. The output of the sound FM transmitter is finally combined with the AM picture transmitter output, through a combining network and fed to a common antenna for radiation of energy in the form of electromagnetic waves.

### **10.8 Monochrome TV receiver**

The simplified block diagram of a black and white TV receiver is shown in Fig 10.20. The receiving antenna intercepts radiated RF signals and the tuner selects the desired channel frequency band. The antenna provides RF picture and sound signals for the RF amplifier stage. The RF amplifier stage is then coupled into the mixer stage. The mixture is connected to the local oscillator. The RF audio and video signals are heterodyned into intermediate frequency by the mixer and local oscillator. The RF amplifier, mixer and local oscillator stages are combinely called as the RF tuner. The output signal from the tuner circuit is amplified by using a common IF amplifier. Then the video and audio components are separated by a detector. The sound signals are detected from FM waves, amplified and then fed into the loud speaker, which reproduce the sound.

The video components are first passed into a detector which separates the picture signal from the synchronising pulses. The line synchronising pulses and the frame synchronising pulses are fed into the horizontal and vertical deflector plates of the picture tube. The blanking pulses are given to the control grid of the electron gun of the picture tube. The picture signals are applied to the filament of the electron gun of the picture tube. According to the variations of potential in the picture, electrons are emitted from the electron gun. Thus, the intensity of the fluorescent screen of the picture tube is in accordance with the variation of potential in the picture and the picture is reproduced.

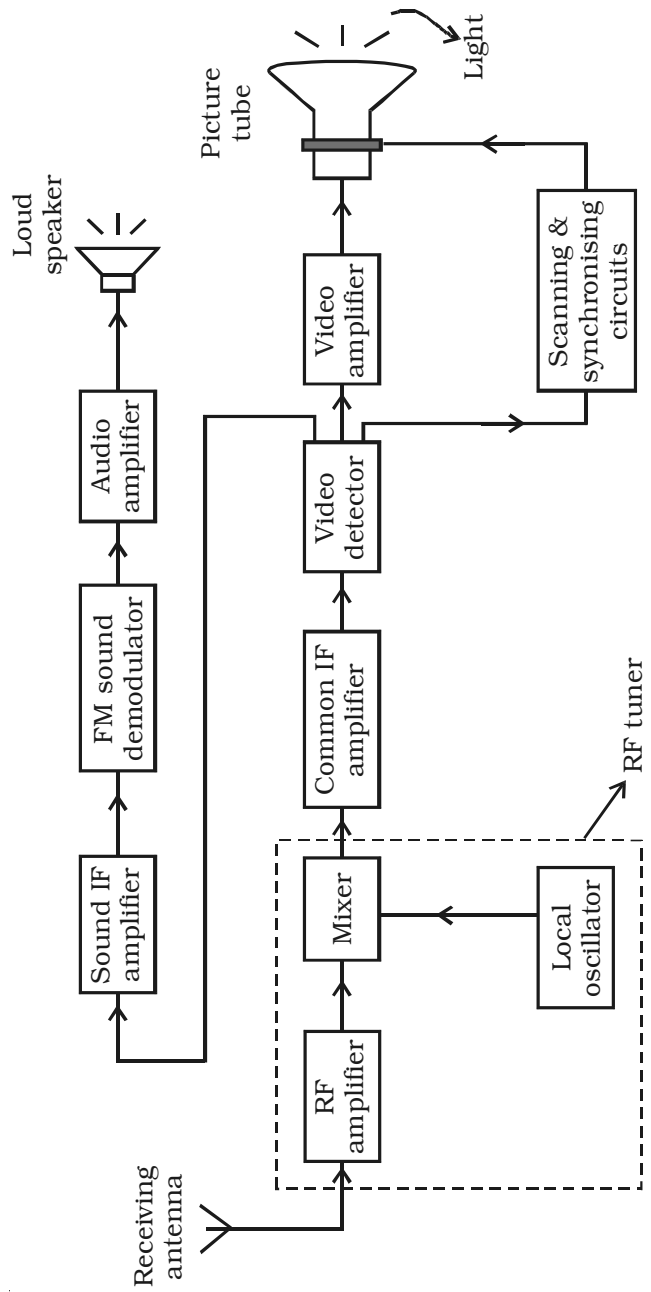

Fig 10.20 Elementary block diagram of a monochrome TV receiver

## **10.9 RADAR**

The term RADAR is an acronym for RAdio Detection And Ranging. It is a system which uses radio waves to detect and to fix the position of targets at a distance.

### **10.9.1 Principle of radar**

Radar works on the principle of 'radio echoes'. The transmitter in a radar, radiates the high power electrical pulses into space. When these pulses are incident on any distant target such as a mountain, ship or aircraft, they get scattered in all directions. The transmitter antenna receives a part of the scattered energy. This transmitter antenna also acts as receiving antenna for the receiving pulse. The pulse travels with the speed of light  $3 \times 10^8 \text{ ms}^{-1}$ . In other words, these pulses cover a distance of 300 metres for every micro second. Hence by measuring the time taken by the pulse to reach the target and back to the transmitter, the range or distance of the target can be easily determined. To locate the direction of the target, directional antennas are used.

### **10.9.2 Transmission and reception of radar**

The block diagram of a simple radar system is shown in Fig 10.21. This block diagram indicates that the radar system consists of both the transmitting and the receiving system.

The transmitting system consists of a transmitter and a pulser. The receiving system consists of a receiver and an indicator. In most of the cases, a single antenna is used for both transmission and reception and this is achieved with the use of TR switch (Transmitter Receiver Switch). This switching arrangement is called as 'duplexer'. This connects the antenna to the transmitter during transmission and to the receiver during reception. Moreover, this switch isolates the sensitive receiver from the damaging effects of the high power transmitter.

The transmitter is essentially a high power magnetron oscillator which generates high power pulses. This transmitter is turned on and off with a periodic pulse from the pulser. Thus the transmitter generates periodic pulses of very short duration. These short pulses are fed to the antenna which radiates them into the space. The antenna is highly directional.

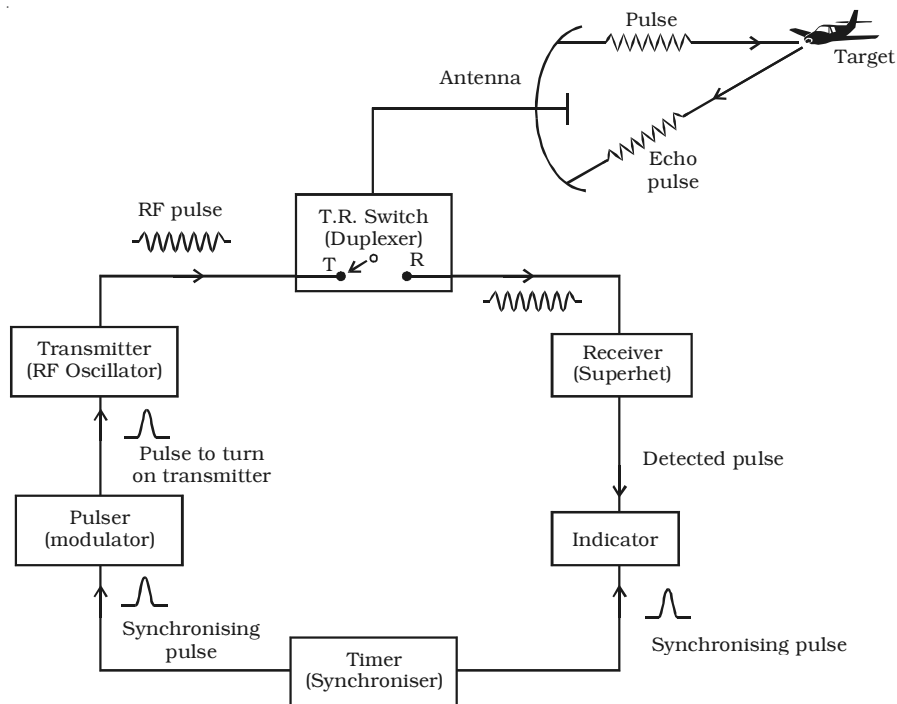

Fig 10.21 Block diagram of a radar system

If the transmitted pulse hits any target, a weak echo signal returns to the same antenna. But, now the TR switch puts the antenna in contact with the receiver. This echo signal is amplified and demodulated by the superhet receiver. The sensitivity of the receiver is very high. The detected output is sent to the indicator. The indicator is a cathode ray tube. The CRT displays the original transmitted pulse as well as the detected echo pulse along a horizontal base line. The synchronising pulse generated by the 'timer' is supplied to both transmitting and receiving systems. So, the indicator records the transmitted pulse as well as the returning pulse simultaneously. The returning echo pulse appears slightly displaced from the transmitted pulse and this displacement is a measure of the range of the target.

**Some applications of radar**

(i) Air and sea navigation is made entirely safe, with radar installations. High flying planes and ship at sea, can get detailed reports of mountains, ice bergs, rivers, lakes, shore lines etc., which they can avoid.

(ii) Radar systems are used for the safe landing of air crafts. On approaching the air field, the pilot is guided by signals from a radar set, so that it flies along the line of the runway and lands safely, whatever be the visibility.

(iii) Rain drops may reflect suitable radar signals and thus enable meteorologists to measure the distance of the clouds, with great accuracy for forecasting.

(iv) The pulses can be used for discovering the position of buried metals, oils and ores.

### **10.10 Analog communication and digital communication**

Based on the type of signals transmitted, communication electronics can be classified as,

- (i) Analog communication and
- (ii) Digital communication

#### **10.10.1 Analog communication**

In analog communication, analog signals are used. An analog signal is a continuously varying voltage or current. Traditionally, in telephone and radio systems, the messages consisted of information conveyed by voice. The voice signal is an analog signal and so could take on any value within the overall range allowed. For example, if the telephone system were set up to handle voice signals, which ranged from 0 to 1 volt, the values transmitted at any instant could be 0.345 V, 0.179 V, and so on. This is called analog signal communication, because the signal can be any value within the range.

#### **Shortcomings of analog communication**

The greatest technical problem with an analog communication system is noise. Noise that comes from any part of the system – the modulator, the transmitter, the communication link, the receiver or the demodulator – can corrupt the signal.

Analog system do not offer opportunities for identifying corrupted signals.

#### **10.10.2 Digital Communication**

A digital communication system offers many advantages to the user, that cannot be achieved with an analog system. Digital communications system may make use of analog links and concepts.

A digital system is a more general case of a binary system. In binary system, only two signal values can exist. They are often called 0 and 1, but these names represent specific voltages.

The term data is commonly used in digital communication systems. Data is any form of information, that has been put into digital form, so that it can be handled by a digital system. The data itself is measured as bit. (bit is a contraction of the term 'binary digit')

The binary signals are easy to generate and process with digital circuits. These digital circuits are available in the IC form and can generate and process digital data at high speeds.

### **Advantages**

(i) The transmission quality is high and almost independent of the distance between the terminals.

(ii) The capacity of the transmission system can be increased.

(iii) The newer types of transmission media such as light beams in optical fibers and wave guides operating in the microwave frequency extensively use digital communication.

### **Disadvantages**

(i) A digital system requires larger bandwidth.

(ii) It is very difficult to gradually change over from analog to digital transmission.

### **10.10.3 Modem**

The name modem is the abbreviation of the term Modulator and Demodulator. As the name implies, both functions are included in a modem. A modem is used to convert digital signals into analog signals capable of being transmitted over telephone lines. At the receiving end of the system, modem is used to demodulate the analog signals and reconstruct the equivalent digital output. Modems are placed at both ends of the communication circuit as shown in Fig 10.22.

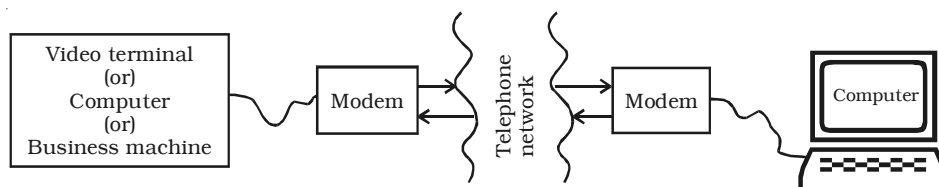

*Fig 10.22 Communication circuit using modem*



#### 10.10.4 Fax (or) Facsimile

Fax (or) Facsimile, is an electronic system for transmitting graphical information by wire or radio. It is used to send printed material by scanning and converting it into electronic signals. These signals modulate a carrier to be transmitted over the telephone lines. Since modulation is involved, fax transmission can also take place by radio.

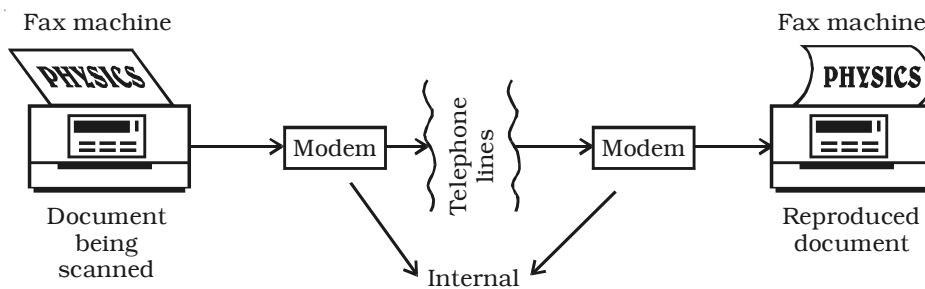

Fig 10.23 Components of a fax system

The components of a fax system are illustrated in Fig 10.23. Although facsimile is used to transmit pictures, it is not TV because it does not transmit sound messages or live scenes and motion. However, it does use scanning techniques that are in same way generally similar to those used in TV. A scanning process is used to break up a printed document into many horizontal scan lines which can be transmitted and reproduced serially.

#### 10.10.5 Wire and Cable

The medium is the actual path for the electromagnetic energy of the link or channel of the communication system. Through the medium, the energy representing the data of the sender can reach the receiver. This path can take many forms : an electrical conductor such as wire, vacuum or optical fiber.

Copper is an inexpensive metal that is easily made into wire, Fortunately, it is also an excellent conductor of electricity. When separate wires are collected into bundles and are given special protective jacketing, the term 'cable' is often used.

The main types of wire and cable used in data communications are (a) Twisted pair (b) Multiconductor flat cable and (c) Coaxial cable and are represented in Fig 10.24.

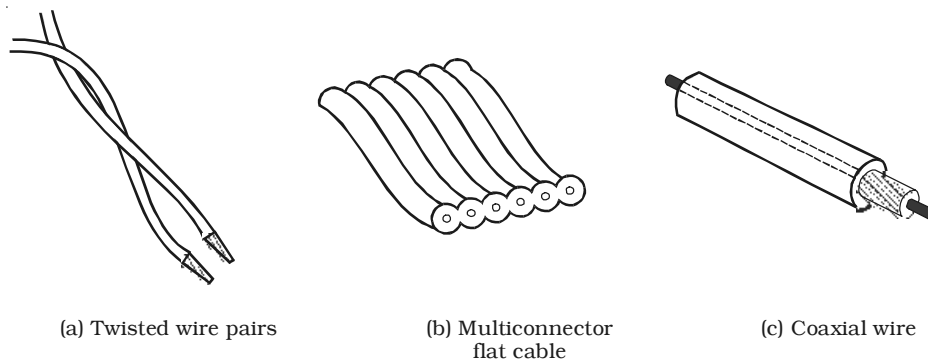

*Fig 10.24 Different types of wire and cable used for communications*

Twisted pair cable is the simplest and lowest cost cable. It consists of two insulated wire twisted around each other in a continuous spiral as shown in Fig 10.36a. The wire is twisted to minimise the external noise. Twisted pair is used between telephones and the central office. It is difficult to use, when many signals must be brought from one place to another.

The multiconductor flat cable consists of many parallel wires in a common plastic jacket as shown in Fig. 10.36b. A cable of this type can have any number from 10 to about 50 wires. All the wires are grouped mechanically and they can be used with a single connector at each end. Flat cable is more expensive than twisted pair.

For some applications, coaxial cable (coax) must be used. It consists of a solid-centre conductor surrounded by a plastic insulator such as teflon. Over the insulator, is a second conductor, a tubular braid or shield made of fine wires. An outer plastic insulation protects and insulates the braid. It is fairly expensive to buy and can be difficult to install, because of its mechanical stiffness and thickness.

#### **10.10.6 Fiber optical communication**

Coherent light can be generated with laser or light emitting diodes and may be detected by photo-diodes. Optical fibers are used for transmission of light.

An optical fiber is a thin transparent rod, usually made of glass or plastic, through which light can propagate. The light signals travel through the rod from the transmitter to the receiver and can be easily detected at the receiving end of the optical fiber. The principle of total

internal reflection is used for the transmission of light signals through the optical fiber.

### **Advantages**

- (i) Transmission loss is low.
- (ii) Fiber is lighter and less bulky than equivalent copper cable.
- (iii) More information can be carried by each fiber than by equivalent copper cables.
- (iv) There is no interference in the transmission of light from electrical disturbances or electrical noise.

### **Applications**

The various applications of fiber in communication area are, voice telephones, video phones, message services, data network etc.

#### **10.10.7 Satellite Communication**

Space technology has witnessed a phenomenal growth, since the launch of man-made satellite Sputnik in 1957. One of the most significant applications of space technology has been in the field of communications. The people over world watch international events like Olympic games via satellite. A number of countries are using satellites for military communications, which include services to ships, air crafts and land mobile terminals. Several direct TV broadcasting satellite systems are also being used.

Satellite communication is basically a microwave link repeater. A satellite receives energy from an earth station, amplifies it and returns it to each at a frequency about 2 GHz away from the uplink frequency (earth to satellite) . This prevents interference between the uplink and the downlink (satellite to earth). Satellite so used is a geostationary satellite which appears to be stationary at a given spot above the equator. Actually, it moves with the same angular velocity as the earth i.e. it completes one revolution per 24 hours and hence appears to be stationed over one spot on the globe. Satellite orbiting the earth will be geostationary when it is about 36,000 km away from the earth.

Fig 10.25 gives the general structure of a satellite communications system. A satellite in space links many earth stations. The user is connected to the earth station through terrestrial network.

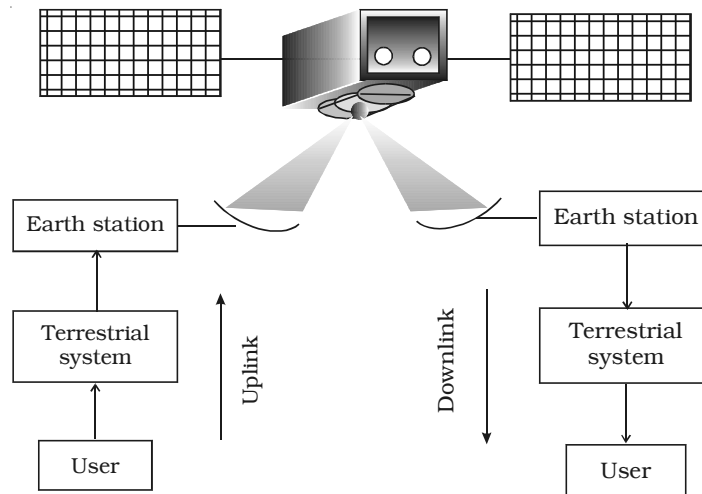

*Fig 10.25 Configuration of a satellite communication*

This network may assume various configurations including a telephone switch or a dedicated link to the earth station. Signal generated by the user is processed and transmitted from the earth station to the satellite. The satellite receives the modulated RF carrier at the pre-determined uplink frequencies from all the earth stations in the network, amplifies these frequencies and then re-transmits them back to earth at downlink frequencies. The downlink frequencies are kept different from the uplink frequencies in order to avoid interference. The modulated carrier received at receiving earth station is processed to get back the original baseband signal. This signal is then sent to the user through a terrestrial network.

As per WARC (World Administrative Radio Conference) 1979 allocation, commercial communication satellites use 500 MHz bandwidth near 6 GHz for uplink transmission and use 500 MHz bandwidth near 4 GHz for downlink transmission. In actual practice, uplink of 5.725 – 7.075 GHz is used while downlink of 3.4 – 4.8 GHz is used.

**Merits**

- (i) Mobile communication can be easily established by satellite communication.
- (ii) Satellite communication is economical compared with terrestrial communication particularly where long distances are involved.

(iii) Compared to the optical fiber communication, satellite communication has the advantages that, quality of transmitted signal and location of sending and receiving stations are independent of distance.

(iv) For thin traffic remote areas like north east regions in India, Ladakh etc., satellite communication is most economical.

(v) For search, rescue and navigation, satellite communication is far superior and economical compared to other systems.

**Demerits**

(i) Between talks there is a time gap which becomes quite annoying. This time delay also reduces the efficiency of satellite in data transmission.

(ii) An imperfect impedance match may cause echo, received back after a delay. Echo suppressor has to be used.

(iii) Repair of satellite is almost impossible, once it has been launched.

### Solved problems

10.1 A 10 MHz sinusoidal carrier wave of amplitude 10 mV is modulated by a 5 kHz sinusoidal audio signal wave of amplitude 6 mV. Find the frequency components of the resultant modulated wave and their amplitude.

**Data:** Frequency of the carrier  $= f_c = 10 \text{ MHz}$   
Frequency of the signal  $= f_s = 5 \text{ kHz} = 0.005 \text{ MHz}$   
Amplitude of the carrier signal  $= E_c = 10 \text{ mV}$   
Amplitude of the audio signal  $= E_s = 6 \text{ mV}$   
Frequency components of modulated wave = ?  
Amplitude of the components in the modulated wave = ?

**Solution :** The modulated carrier wave contains the following frequencies :

- (i) Original carrier wave of frequency  $= f_c = 10 \text{ MHz}$
- (ii) Upper side band frequency,  $f_c + f_s = 10 + 0.005$   
 $= 10.005 \text{ MHz}$
- (iii) Lower side band frequency  $f_c - f_s = 10 - 0.005$   
 $= 9.995 \text{ MHz}$

The modulation factor is,

$$m = \frac{E_s}{E_c} = \frac{6}{10} = 0.6$$

$$\therefore \text{Amplitude of USB} = \text{Amplitude of LSB} = \frac{mE_c}{2} = \frac{0.6 \times 10}{2} = 3 \text{ mV}$$

10.2 An FM signal has a resting frequency of 105 MHz and highest frequency of 105.03 MHz when modulated by a signal. Determine (i) frequency deviation and (ii) carrier swing.

**Data :** Resting frequency ( $f$ ) = 105 MHz  
Frequency of the signal ( $f_s$ ) = 5 kHz  
Highest frequency of the modulated wave, ( $f_m$ ) = 105.03 MHz  
Frequency deviation =  $\Delta f$  = ?      Carrier swing (CS) = ?

**Solution :** Frequency deviation ( $\Delta f$ ) =  $f_m - f$

$$\Delta f = 105.03 - 105 = 0.03 \text{ MHz}$$

$$\text{Carrier swing} = 2 \times \Delta f = 2 \times 0.03 = 0.06 \text{ MHz} = 60 \text{ kHz}$$

## Self evaluation

*(The questions and problems given in this self evaluation are only samples. In the same way any question and problem could be framed from the text matter. Students must be prepared to answer any question and problem from the text matter, not only from the self evaluation.)*

- 10.1 High frequency waves follow
- (a) the ground wave propagation
  - (b) the line of sight direction
  - (c) ionospheric propagation
  - (d) the curvature of the earth
- 10.2 The main purpose of modulation is to
- (a) combine two waves of different frequencies
  - (b) acquire wave shaping of the carrier wave
  - (c) transmit low frequency information over long distances efficiently
  - (d) produce side bands
- 10.3 In amplitude modulation
- (a) the amplitude of the carrier wave varies in accordance with the amplitude of the modulating signal.
  - (b) the amplitude of the carrier wave remains constant
  - (c) the amplitude of the carrier varies in accordance with the frequency of the modulating signal
  - (d) modulating frequency lies in the audio range
- 10.4 In amplitude modulation, the band width is
- (a) equal to the signal frequency
  - (b) twice the signal frequency
  - (c) thrice the signal frequency
  - (d) four times the signal frequency
- 10.5 In phase modulation
- (a) only the phase of the carrier wave varies
  - (b) only the frequency of the carrier wave varies.
  - (c) both the phase and the frequency of the carrier wave varies.
  - (d) there is no change in the frequency and phase of the carrier wave

- 10.6 The RF channel in a radio transmitter produces
- audio signals
  - high frequency carrier waves
  - both audio signal and high frequency carrier waves
  - low frequency carrier waves.
- 10.7 The purpose of dividing each frame into two fields so as to transmit 50 views of the picture per second is
- to avoid flicker in the picture
  - the fact that handling of higher frequencies is easier
  - that 50 Hz is the power line frequency in India
  - to avoid unwanted noises in the signals
- 10.8 Printed documents to be transmitted by fax are converted into electrical signals by the process of
- reflection
  - scanning
  - modulation
  - light variation
- 10.9 What are the different types of radio wave propagation?
- 10.10 Explain the ground wave propagation.
- 10.11 Explain the wave propagation in ionosphere.
- 10.12 What is meant by skip distance?
- 10.13 What is the necessity of modulation?
- 10.14 Explain amplitude modulation.
- 10.15 Define modulation factor.
- 10.16 Define bandwidth.
- 10.17 What are the limitations of amplitude modulation?
- 10.18 Explain frequency modulation.
- 10.19 What is phase modulation?
- 10.20 Define directivity.
- 10.21 Draw the block diagram of AM radio transmitter.
- 10.22 Explain the function of FM transmitter with neat block diagram.
- 10.23 What is meant by scanning?



- 10.24 *What is interlaced scanning?*
- 10.25 *Explain the function of a vidicon camera tube.*
- 10.26 *Explain the functions of various units in the monochrome television transmission.*
- 10.27 *Explain the functional block diagram of a monochrome TV receiver.*
- 10.28 *Explain the principle of radar.*
- 10.29 *What are the applications of radar?*
- 10.30 *Explain the principle of modem.*
- 10.31 *What are the different types of wire and cable used for telecommunication system ?*
- 10.32 *What are the advantages of fiber optic communication system?*
- 10.33 *In a broadcasting studio, a 1000 kHz carrier is modulated by an audio signal of frequency range, 100–5000 Hz. Find (i) maximum and minimum frequencies of USB (ii) maximum and minimum frequencies of LSB and (iii) width of the channel.*

### **Answers**

- 10.1** (c)            **10.2** (c)            **10.3** (a)            **10.4** (b)
- 10.5** (c)            **10.6** (b)            **10.7** (a)            **10.8** (b)
- 10.33** 1005 kHz and 1000.1 kHz,  
999.9 kHz and 995 kHz, 10 kHz.

## APPENDIX

(Not for examination)

### ***Applications of discharge phenomenon in illumination***

The phenomenon of the low pressure electric discharge has been put to use in different branches of science and industry. Perhaps, the most important of these is the use of discharge tubes as sources of light in spectral analysis and of fluorescent tubes for lighting purposes. We shall discuss here only the modern lamps of great luminosity such as (i) the sodium lamp, (ii) the mercury vapour lamp and (iii) the fluorescent lamp.

#### ***(i) Sodium vapour lamp***

This is a lamp based on hot cathode positive column discharge.

The Sodium Vapour lamp is shown in figure. The discharge tube is bent in the form of a U-tube with electrodes  $E_1$  and  $E_2$  fused at the two ends. Some specks of metallic sodium are deposited on the inner walls of the tube. The tube also contains a very small quantity of neon gas at a pressure of about 10 mm of mercury. This is used as a catalyst to start the discharge. The lamp requires an operating temperature of about  $300^\circ\text{C}$  for good luminosity. To minimize heat losses, the discharge tube is surrounded by a double-walled vacuum tube. For the discharge to start, a voltage of about 400 volts is required, which is supplied by a leak transformer.

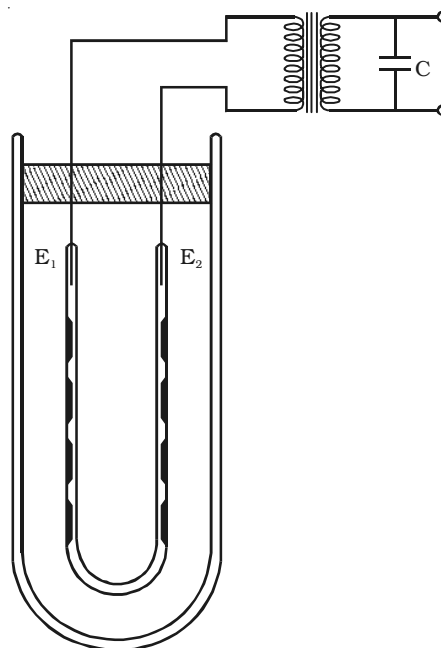

Initially the discharge passes through neon gas and the colour of the light is red. The heat of the discharge is sufficient to vapourise the metallic sodium and thereafter the discharge passes preferentially through sodium vapour. This results in the familiar brilliant yellow light. The operating voltage of the lamp is then only 220 volts.

The sodium vapour lamp is commonly used in the Physics laboratory as a source of monochromatic (single colour) light. It is used for lighting up show-cases in shops and public places.

**(ii) Mercury vapour lamp**

The mercury vapour lamp is also of the hot cathode type and operates at a temperature of about  $600^{\circ}\text{C}$ . The construction is similar to that of sodium vapour lamp and is shown in Figure.

The inner vessel contains a small amount of mercury and argon gas at a pressure of 10 mm. mercury. This has two main electrodes sealed at its two ends and also a starting electrode. This is surrounded by a outer vacuum jacket. The starting

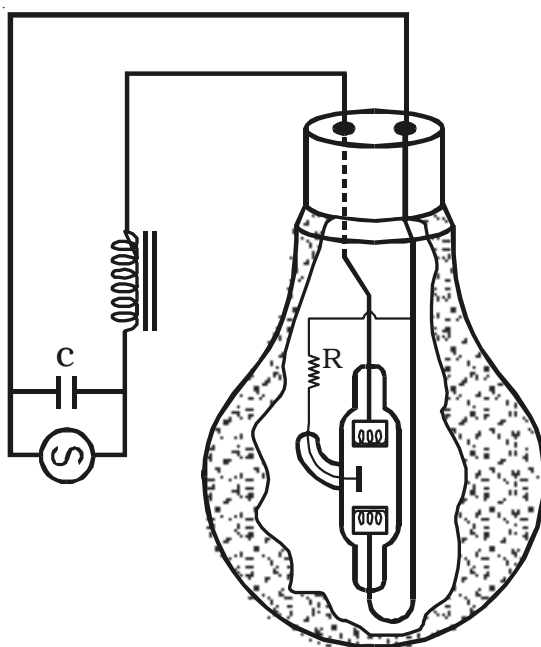

electrode helps to start the discharge through argon. As time elapses, mercury vapourises and maintains the discharge, giving a very brilliant light. It works at a lower voltage and proper choke is provided for use with it.

The light from the lamp is rich in ultraviolet, violet, blue and green. Mercury lamps are now very commonly used for street lighting purposes and in Physics laboratory.

### **(iii) The fluorescent lamp**

Fluorescent lamp is a type of gas discharge tube, which is commonly called as tube light. It consists of a glass tube whose ends are sealed with a pair of electrodes, one at each end. The tube contains a droplet of mercury and an inert gas argon at very low pressure of 1 mm of Hg. The electrodes consist of tungsten filaments. The inner surface of the tube is coated with a phosphor, which produces visible light, when excited with ultraviolet radiation.

When the lamp is switched on with 220 V a.c., the full voltage is applied across the electrodes of a neon lamp (starter).

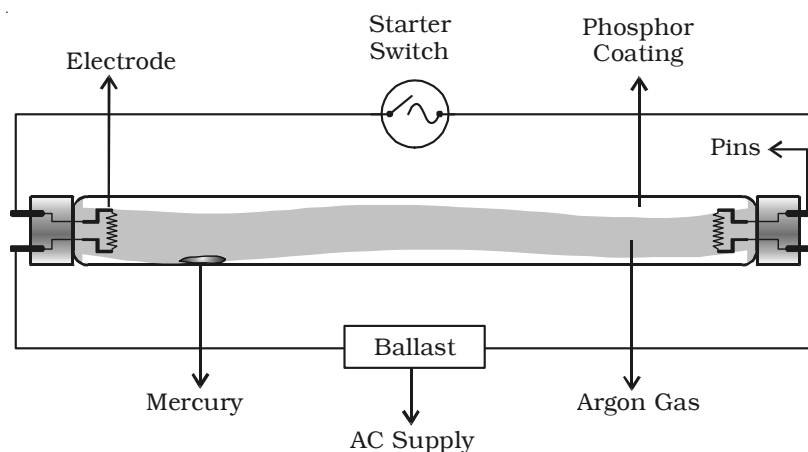

The neon glows and warms up the electrodes, one of which is a bimetallic element. The bimetal expands and touches the other electrode, thus short - circuiting the starter. This causes an appreciable current to flow through the filaments. In a short

time, the filaments become hot and by this time the neon lamp cools off. The bimetal contracts and breaks the circuit in the neon lamp creating a voltage surge in the circuit, because of the presence of the ballast (inductor). This momentary increase in the voltage causes an electric discharge to take place in mercury – argon mixture between the two filaments. Once this discharge is maintained, the potential difference across the neon starter is too small to create the discharge in the starter.

During the discharge inside the bulb, considerable amount of ultraviolet radiation is produced, which is absorbed by the phosphor coating on the inner walls of the tube and emits visible light.

A ballast is an inductor, which at 50 Hz has appropriate impedance to limit the current to the proper value. It provides the necessary starting kick to ionize the gas in the tube.

Usually the zinc sulphate and cadmium borate are used as phosphors. Hence, white light is coming out. By varying the phosphors, colour is obtained.

The fluorescent lamps are characterized by higher luminosity than ordinary filament bulbs for a given power consumption and are being increasingly used for domestic lighting purposes. They also minimize glare and thick shadows. The average life of these lamps is also high.

### **MODERN TELEVISION SCREEN**

For the function of picture tube (CRT) used in television, high currents and voltages are required. (Also, CRT generates very strong electromagnetic fields.) The strong intense electromagnetic radiations affect human eye and CRT occupies large space. In order to avoid this, nowadays, CRTs are replaced by flat monitors such as monitors used in lap-top computers. The LEDs or LCDs can be used for the fabrication of flat panel displays. In near future, all types of CRTs used in display devices such as computer monitors, television picture tube will be replaced by the flat LCD displays.



















## Fundamental Physical Constants and Useful Data

1. Atomic mass unit	amu	1.66 × 10 <sup>-27</sup> kg
2. Avogadro's number	N <sub>A</sub>	6.02 × 10 <sup>23</sup> mol <sup>-1</sup>
3. Electron mass	m <sub>e</sub>	9.11 × 10 <sup>-31</sup> kg
4. Electron - volt	eV	1.602 × 10 <sup>-19</sup> J
5. Fundamental charge	e	1.602 × 10 <sup>-19</sup> C
6. Neutron mass	m <sub>n</sub>	1.67 × 10 <sup>-27</sup> kg
7. Permeability of free space	μ <sub>0</sub>	4π × 10 <sup>-7</sup> H/m
8. Permittivity of free space	ε <sub>0</sub>	8.854 × 10 <sup>-12</sup> C <sup>2</sup> N <sup>-1</sup> m <sup>-2</sup>
9. Planck's constant	h	6.626 × 10 <sup>-34</sup> Js
10. Proton mass	m <sub>p</sub>	1.67 × 10 <sup>-27</sup> kg
11. Electron charge to mass ratio	e/m	1.759 × 10 <sup>11</sup> C/kg
12. Bohr radius	r <sub>1</sub>	0.53Å
13. Rydberg's constant	R	1.094 × 10 <sup>7</sup> m <sup>-1</sup>
14. Energy equivalent to 1 amu		931 MeV
15. Hydrogen ground state energy		-13.6 eV
16. Speed of light in vaccum		3.00 × 10 <sup>8</sup> m/s

## **Bibliography**

**Advanced Physics**, Keith Gibbs, Cambridge University Press (1996).

**College Physics**, R.L. Weber, K.V. Manning, M.W. White and G.A. Weygand, Tata McGraw Hill (1977).

**Fundamentals of Physics**, Sixth Edition, David Halliday, Robert Resnick and Jeart Walker, John Wiley (2001).

**Fundamental University Physics**, M. Alonso & E.J. Finn, Addison - Wesley (1967).

**General Physics**, Morton M. Sternheim and Joseph W. Kane, John Wiley (1986).

**Physics Foundations and Frontiers**, G. Gamov and J.M. Clereland, Tata McGraw Hill (1978).

**University Physics**, H.D. Young, M.W. Zemansky and F.W. Sears, Narosa Publications House (1982).

**University Physics**, Ronald Lane Reese, Brookes/cole Publishing Company (1998).

**Introduction to Atomic and Nuclear Physics** - H.Semat and J.R. Albright.

**Nuclear Physics** - D.G. Tayal, Himalaya Publishing House.

**Electronic Principles** - Malvino, Third Edition, Tata McGraw Hill Publishing Company Ltd., New Delhi (1984).

Contd.....

**Electronic Devices and Circuits**, Theodore F-Bogart, Universal Book Stall, New Delhi (1990).

**Digital Principles and Applications**, Albert Paul Malvino & Donald P. Leach, Third Edition, Tata Mcgraw Hill Publishing Company Ltd., New Delhi (1981)

**Hand Book of Electronics**, Gupta & Kumar - Pragati Prakashan, Meerut.

**Digital Fundamentals - Third Edition**, Floyd, Universal Book Stall, New Delhi (1986).

**Electronics Communications**, Roddy Coolen - Prentice Hall of India.

**Communication Electronics - Principles and Applications**, Third Edition, Louis E.Frenzel, Mc Graw - Hill, New York (2000).

**Basic Television and Video Systems**, Fifth edition, Bernard Grob, Mc Graw Hill, New York (1984).