

# **Electronic Equipments**

## **Theory**

**Vocational Education**  
**HIGHER SECONDARY - SECOND YEAR**

A Publication under  
Government of Tamilnadu  
Distribution of Free Textbook Programme  
(Not For Sale)

**Untouchability is a sin**  
**Untouchability is a crime**  
**Untouchability is inhuman**



**TAMILNADU**  
**TEXTBOOK CORPORATION**  
**College Road, Chennai - 600 006.**

## **CHAIR PERSON**

**Dr.R.S.D. Wahida Banu**

Professor and Head,  
Department of Electronics & Communication Engineering,  
Government College of Engineering,  
Salem - 636 011.

## **AUTHORS**

**Dr. M. Chandrasekar**

Associate Professor,  
Department of Electronics &  
Communication Engineering,  
Government College of Engineering,  
Salem - 636 011.

**Miss. S. Salma Mehajaben**

Lecturer,  
Department of Electronics &  
Communication Engineering,  
Government College of Engineering,  
Salem - 636 011.

**Mr. C.Amirdalingam**

Vocational Teacher,  
Govt.Hr.Sec.School,  
Yethapur- 636 117  
Salem District.

**Mrs. G.Umamaheswari**

Vocational Teacher,  
Govt.Hr.Sec.School,  
Mettupatty- 636 111  
Salem District.

This book has been prepared by the Directorate of School Education  
on behalf of the Government of Tamilnadu

This Book has been printed on 60 GSM Paper

Printed by web offset at :

# HIGHER SECONDARY – VOCATIONAL ELECTRONIC EQUIPMENTS

## 12<sup>th</sup> Std Syllabus

### Unit 1 : Digital Circuits

- 1.1. Introduction – Multivibrators – Astable – Monostable – Bistable (IC 555)
- 1.2. Basic gates – NOR – NAND – EX – NOR – Construction – Verification of Truth table
- 1.3. Half adder – Full adder – Full subtractor
- 1.4. Flipflop – Registers
- 1.5. Counters – Encoder – Decoder – Multiplexer

### Unit 2 : Network Antenna and Propagation

- 2.1. Introduction – Modulation – Demodulation – MODEM
- 2.2. Pulse Modulation techniques – PAM – PTM – FWM – PPM
- 2.3. Pulse Digital Modulation – Pulse Code modulation
- 2.4. Microwave transmission
- 2.5. Antenna Introduction – Transmitting antenna – types
- 2.6. Receiving antenna –  $\lambda$  - Yagi – Dish antenna – LNB – Satellite receiver

### Unit 3 : Radio Transmission and Reception

- 3.1. Introduction – Transmission Principle – Types – AM Transmitter – FM transmitter
- 3.2. Receivers – Principle – TRF receiver
- 3.3. Superhetrodyne Principle – AM, FM receivers – communication receiver
- 3.4. Construction of AM receiver – Construction of FM receiver
- 3.5. Alignment, Faults and Rectification techniques

### Unit 4 : TV Transmission and Reception

- 4.1. Introduction – TV transmission principle
- 4.2. Camera tube – types
- 4.3. B/W TV Principle – Colour TV principle
- 4.4. TV tuner – types
- 4.5. Video stages
- 4.6. Sync stages and deflection unit
- 4.7. Power supply – types
- 4.8. Audio stage
- 4.9. Alignment, Faults and Rectification techniques

### Unit 5 : Audio and Video Equipments

- 5.1. Introduction – Gramophone – Recording techniques
- 5.2. Magnetic tape – Tape recorder – Mono – Stereo – Spool type
- 5.3. Compact Disc – VCD, MP3, DVD, MP4, Blue Ray
- 5.4. Memory Card USB
- 5.5. Home Theatre – Dolby – DTS

## **Unit 6 : Tranceivers**

- 6.1. Introduction – Cell Phone – PCS, GSM, CDMA, TDMA Transmission
- 6.2. Infra red – Blue tooth, GPRS, Camera, VGA, Pixel type
- 6.3. Half Duplex – Full duplex – Channel range – Cell phone frequency – Radio frequency – Radio Telephony
- 6.4. WLL – Satellite Phone

## **Unit 7 : Digital Computer**

- 7.1. Introduction – Analog – Digital – Evaluation of DC
- 7.2. Fundamentals of DC – Generations of Computer – Generations of Language – Major Division of CPU – I/P and O/P Devices – Compilers and Interpreter

## **Unit 8 : Telecommunication**

- 8.1. Introduction – OFC
- 8.2. Microwave Transmission and Reception
- 8.3. Types of Satellite – Application
- 8.4. RADAR – SONAR

## **Unit 9 : Medical Electronic Equipments**

- 9.1. Introduction – Electronic blood testing equipment
- 9.2. ECG
- 9.3. CT Scan and ultrasound
- 9.4. Electronic BP apparatus
- 9.5. Digital Thermometers
- 9.6. EEG
- 9.7. Digital X-Ray
- 9.8. Nano technology and its applications

**HIGHER SECONDARY – VOCATIONAL  
ELECTRONIC EQUIPMENTS**

**INDEX**

	<b>Page No.</b>
<b>Unit 1 : Digital Circuits</b>	<b>1 - 15</b>
<b>Unit 2 : Network Antenna and Propagation</b>	<b>16 - 30</b>
<b>Unit 3 : Radio Transmission and Reception</b>	<b>31 - 60</b>
<b>Unit 4 : TV Transmission and Reception</b>	<b>61 - 126</b>
<b>Unit 5 : Audio and Video Equipments</b>	<b>127 - 139</b>
<b>Unit 6 : Tranceivers</b>	<b>140 - 156</b>
<b>Unit 7 : Digital Computer</b>	<b>157 - 170</b>
<b>Unit 8 : Telecommunication</b>	<b>171 - 179</b>
<b>Unit 9 : Medical Electronic Equipments</b>	<b>180 - 191</b>



# 1. DIGITAL CIRCUITS

## 1.1 INTRODUCTION

In a digital system, a more precise representation of a signal can be obtained by using more binary digits to represent it. While this requires more digital circuits to process the signals, each digit is handled by the same kind of hardware. In an analog system, additional resolution requires fundamental improvements in the linearity and noise characteristics of each step of the signal chain.

Computer-controlled digital systems can be controlled by software, allowing new functions to be added without changing hardware. Often this can be done outside of the factory by updating the product's software. So, the product's design errors can be corrected after the product is in a customer's hands.

Information storage can be easier in digital systems than in analog ones. The noise-immunity of digital systems permits data to be stored and retrieved without degradation. In an analog system, noise from aging and wear degrade the information stored. In a digital system, as long as the total noise is below a certain level, the information can be recovered perfectly.

Digital circuits are made from analog components. The design must assure that the analog nature of the components doesn't dominate the desired digital behavior. Digital systems must manage noise and timing margins, parasitic inductances and capacitances, and Tool flows for large logic systems such as microprocessors can be thousands of commands long, and combine the work of hundreds of engineers. power connections.

## MULTIVIBRATOR

A multivibrator is an electronic circuit used to implement a variety of simple two-state systems such as oscillators, timers and flip-flops. It is characterized by two amplifying devices (transistors, electron tubes or other devices) cross-coupled by resistors and capacitors.

There are three types of multivibrator circuit:

- Astable, in which the circuit is not stable in either state it continuously oscillates from one state to the other. Due to this, it does not require a input (Clock pulse or other).
- Monostable, in which one of the states is stable, but the other is not the circuit will flip into the unstable state for a determined period, but will eventually return to the stable state. This circuit is also known as a one shot.
- Bistable, in which the circuit will remain in either state indefinitely. The circuit can be flipped from one state to the other. This circuit is also known as a latch or a flip-flop.

## MONOSTABLE MODE

The relationships of the trigger signal, the voltage on C and the pulse width in monostable mode In the monostable mode, the 555 timer acts as a "one-shot" pulse generator. The pulse begins when the 555 timer receives a signal at the trigger input that falls below a third of the voltage supply. The width of the pulse is determined by the time constant of an RC network, which consists of a capacitor (C) and a resistor (R). The pulse ends when the charge on the C equals

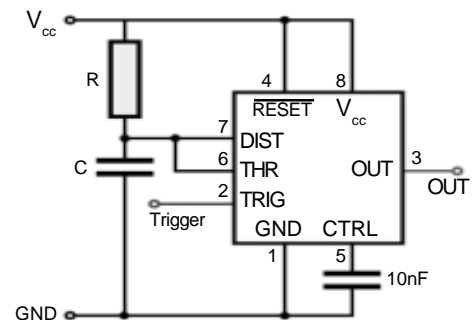

Figure.1.1 IC 555 in monostable mode

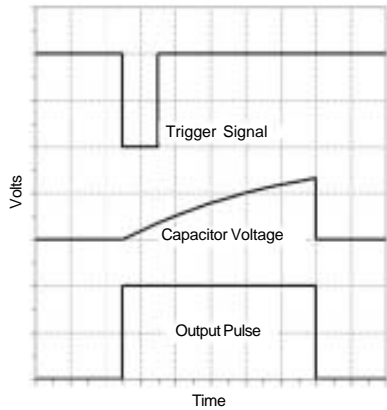

Figure.1.2

$2/3$  of the supply voltage. The pulse width can be lengthened or shortened to the need of the specific application by adjusting the values of  $R$  and  $C$ . The pulse width of time  $t$ , which is the time it takes to charge  $C$  to  $2/3$  of the supply voltage.

The pulse width of time  $t$ , which is the time it takes to charge  $C$  to  $2/3$  of the supply voltage, is given by

$$t = RC \ln(3) \approx 1.1RC$$

where  $t$  is in seconds,  $R$  is in ohms and  $C$  is in farads. See RC circuit for an explanation of this effect.

## BISTABLE MODE

In bistable mode, the 555 timer acts as a basic flip-flop. The trigger and reset inputs (pins 2 and 4 respectively on a 555) are held high via pull-up resistors while the threshold input (pin 6) is simply grounded. Thus configured, pulling the trigger momentarily to ground acts as a 'set' and transitions the output pin (pin 3) to  $V_{cc}$  (high state). Pulling the reset input to ground acts as a 'reset' and transitions the output pin to ground (low state). No capacitors are required in a bistable configuration. Pins 5 and 7 (control and discharge) are left floating.

## ASTABLE MODE

In astable mode, the '555 timer' puts out a continuous stream of rectangular pulses having a specified frequency. Resistor  $R_1$  is connected between  $V_{cc}$  and the discharge pin (pin 7) and another resistor ( $R_2$ ) is connected between the discharge pin (pin 7), and the trigger (pin 2) and threshold (pin 6) pins that share a common node. Hence the capacitor is charged through  $R_1$  and  $R_2$ , and discharged only through  $R_2$ , since pin 7 has low impedance to ground during output low intervals of the cycle, therefore discharging the capacitor. In the astable mode, the frequency of the pulse stream depends on the values of  $R_1$ ,  $R_2$  and  $C$ :

$$f = \frac{1}{\ln(2) \cdot C \cdot (R_1 + 2R_2)}$$

The high time from each pulse is given by

$$high = \ln(2) \cdot (R_1 + 2R_2) \cdot C$$

and the low time from each pulse is given by

$$low = \ln(2) \cdot 2R_2 \cdot C$$

where  $R_1$  and  $R_2$  are the values of the resistors in ohms and  $C$  is the value of the capacitor in farads.

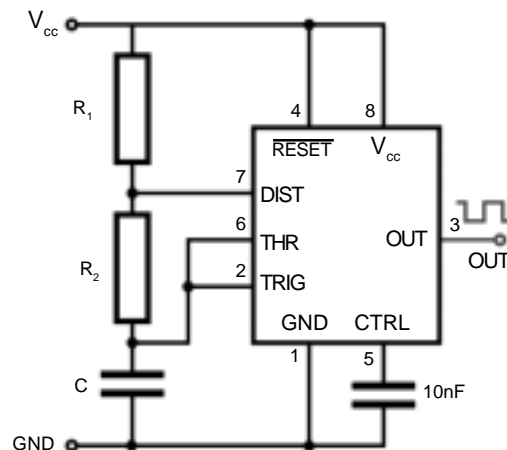

Figure.1.3 Standard 555 Astable Circuit

## 1.2 DEVELOPED LOGIC GATES

Logic gates process signals which represent **true** or **false**. Normally the positive supply voltage  $+V_s$  represents true and  $0V$  represents false. Other terms which are used for the true and false states



Logic states	
True	False
1	0
High	Low
+Vs	0V
On	Off

are shown in the table on the right. It is best to be familiar with them all. Gates are identified by their function: NOT, AND, NAND, OR, NOR, EX-OR and EX-NOR. Capital letters are normally used to make it clear that the term refers to a logic gate.

### LOGIC GATE SYMBOLS

There are two series of symbols for logic gates:

- The **traditional symbols** have distinctive shapes making them easy to recognize so they are widely used in industry and education.



Figure.1.4

- The IEC (International Electrotechnical Commission) symbols are rectangles with a symbol inside to show the gate function. They are rarely used despite their official status, but you may need to know them for an examination.

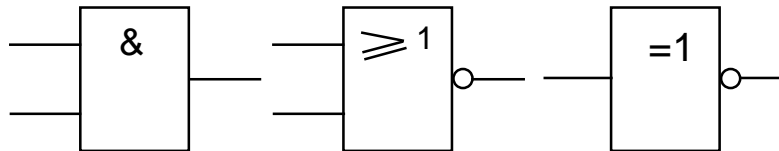

Figure.1.5

### INPUTS AND OUTPUTS

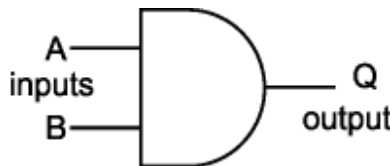

Figure.1.6

Gates have two or more inputs, except a NOT gate which has only one input. All gates have only one output. Usually the letters A, B, C and so on are used to label inputs, and Q is used to label the output. On this page the inputs are shown on the left and the output on the right.

### THE INVERTING CIRCLE (O)

Some gate symbols have a circle on their output which means that their function includes **inverting** of the output. It is equivalent to feeding the output through a NOT gate. For example the NAND (Not AND) gate symbol shown on the right is the same as an AND gate symbol but with the addition of an inverting circle on the output.

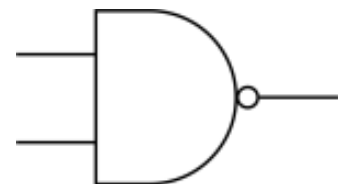

Figure.1.7

### TRUTH TABLES

Input A	Input B	Output Q
0	0	0
0	1	0
1	0	0
1	1	1

A truth table is a good way to show the function of a logic gate. It shows the output states for every possible combination of input states. The symbols 0 (false) and 1 (true) are usually used in truth tables. The example truth table on the right shows the inputs and output of an AND gate. There are summary truth tables below showing the output states for all types of 2-input and 3-input gates.

These can be helpful if you are trying to select a suitable gate.

## LOGIC ICs

Logic gates are available on special ICs (chips) which usually contain several gates of the same type, for example the 4001 IC contains four 2-input NOR gates. There are several families of logic ICs and they can be split into two groups:

- 4000 Series
- 74 Series

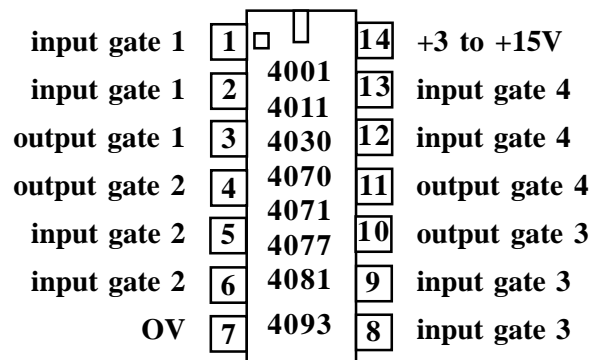

Figure.1.8

### NOT GATE (INVERTER)

The output Q is true when the input A is NOT true, the output is the inverse of the input:

$$Q = \text{NOT } A$$

A NOT gate can only have one input. A NOT gate is also called an inverter.

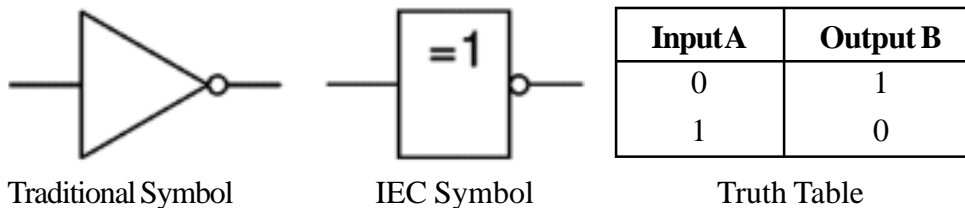

Figure.1.9

### AND GATE

The output Q is true if input A AND input B are both true:  $Q = A \text{ AND } B$

An AND gate can have two or more inputs, its output is true if all inputs are true.

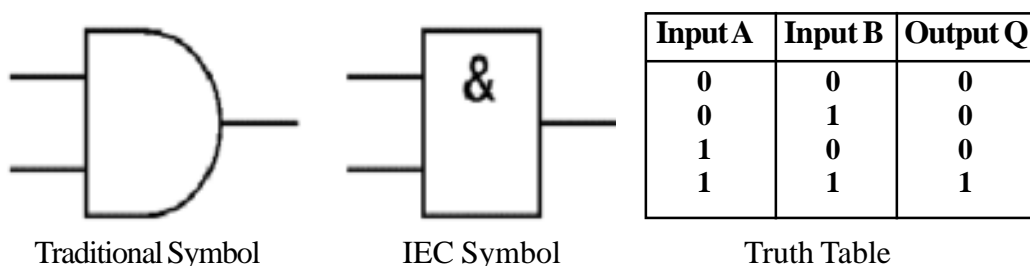

Figure.1.10

### NAND GATE (NAND = NOT AND)

This is an AND gate with the output inverted, as shown by the 'o' on the output.

The output is true if input A AND input B are NOT both true:  $Q = \text{NOT } (A \text{ AND } B)$

A NAND gate can have two or more inputs, its output is true if NOT all inputs are true.

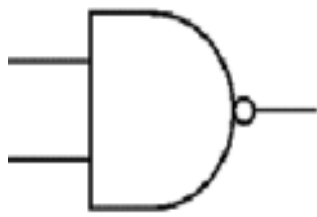

Traditional Symbol

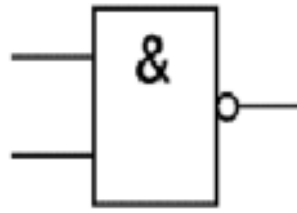

IEC Symbol

Input A	Input B	Output Q
0	0	1
0	1	1
1	0	1
1	1	0

Truth Table

Figure.1.11

## OR GATE

The output Q is true if input A OR input B is true (or both of them are true):  $Q = A \text{ OR } B$

An OR gate can have two or more inputs, its output is true if at least one input is true.

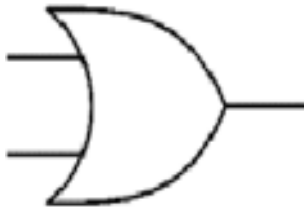

Traditional Symbol

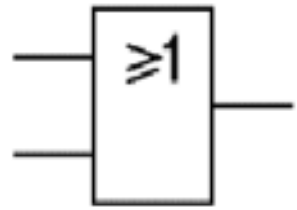

IEC Symbol

Input A	Input B	Output Q
0	0	0
0	1	1
1	0	1
1	1	1

Truth Table

Figure.1.12

## NOR GATE (NOR = NOT OR)

This is an OR gate with the output inverted, as shown by the 'o' on the output.

The output Q is true if NOT inputs A OR B are true:  $Q = \text{NOT } (A \text{ OR } B)$

A NOR gate can have two or more inputs, its output is true if no inputs are true.

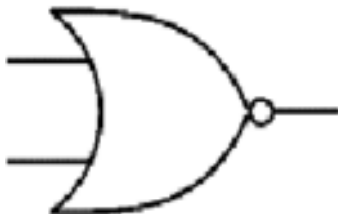

Traditional Symbol

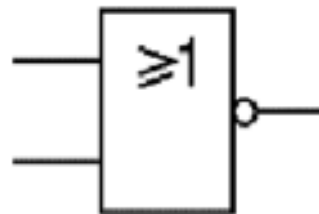

IEC Symbol

Input A	Input B	Output Q
0	0	1
0	1	0
1	0	0
1	1	0

Truth Table

Figure.1.13

## EX-OR (EXCLUSIVE-OR) GATE

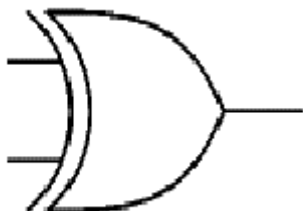

Traditional Symbol

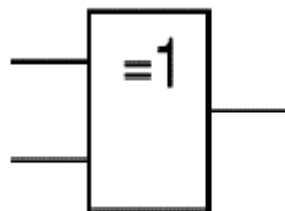

IEC Symbol

Input A	Input B	Output Q
0	0	0
0	1	1
1	0	1
1	1	0

Truth Table

Figure.1.14

The output Q is true if either input A is true OR input B is true, **but not when both of them are true**:  $Q = (A \text{ AND NOT } B) \text{ OR } (B \text{ AND NOT } A)$

This is like an OR gate but excluding both inputs being true. The output is true if inputs A and B are **DIFFERENT**. EX-OR gates can only have 2 inputs.

### EX-NOR (EXCLUSIVE-NOR) GATE

This is an EX-OR gate with the output inverted, as shown by the 'o' on the output.

The output Q is true if inputs A and B are the **SAME** (both true or both false):  $Q = (A \text{ AND } B) \text{ OR } (\text{NOT } A \text{ AND NOT } B)$

EX-NOR gates can only have 2 inputs.

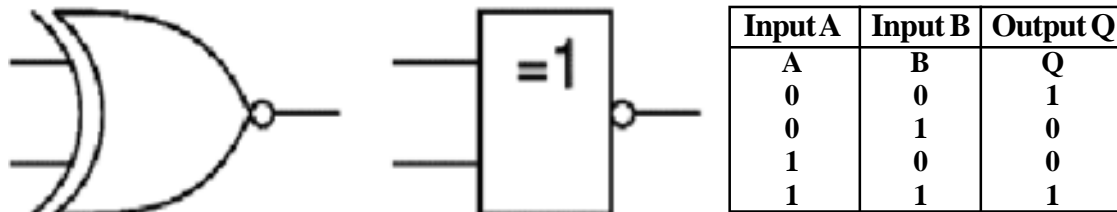

Truth Table

Figure.1.14

### SUMMARY TRUTH TABLES

The summary truth tables below show the output states for all types of 2-input and 3-input gates.

Summary for all 2-input gates							
Inputs		Output of each gate					
A	B	AND	NAND	OR	NOR	EX-OR	EX-NOR
0	0	0	1	0	1	0	1
0	1	0	1	1	0	1	0
1	0	0	1	1	0	1	0
1	1	1	0	1	0	0	1

Summary for all 3-input gates						
Inputs			Output of each gate			
A	B	C	AND	NAND	OR	NOR
0	0	0	0	1	0	1
0	0	1	0	1	1	0
0	1	0	0	1	1	0
0	1	1	0	1	1	0
1	0	0	0	1	1	0
1	0	1	0	1	1	0
1	1	0	0	1	1	0
1	1	1	1	0	1	0

Note that EX-OR and EX-NOR gates can only have 2 inputs.

### 1.3 ADDER AND SUBTRACTOR

In electronics, an adder or summer is a digital circuit that performs addition of numbers. In modern computers adders reside in the arithmetic logic unit (ALU) where other operations are performed. Although adders can be constructed for many numerical representations, such as Binary-coded decimal or excess-3.

#### HALF ADDER

A **half adder** is a logical circuit that performs an addition operation on two one-bit binary numbers often written as A and B. The half adder output is a sum of the two inputs usually represented with the signals  $C_{out}$  and S where  $sum = 2 \times C_{out} + S$ . Following is the logic table for a half adder:

As an example, a Half Adder can be built with an XOR gate and an AND gate.

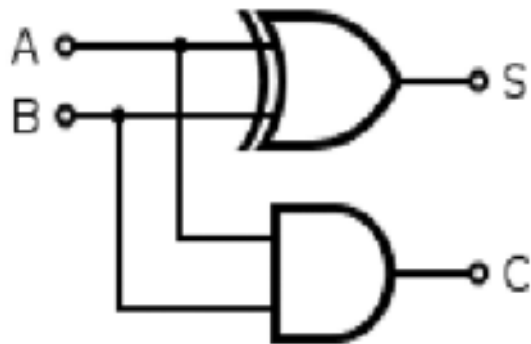

Inputs		Outputs	
A	B	C	S
0	0	0	0
0	1	0	1
1	0	0	1
1	1	1	0

Figure.1.15 Example half adder circuit diagram

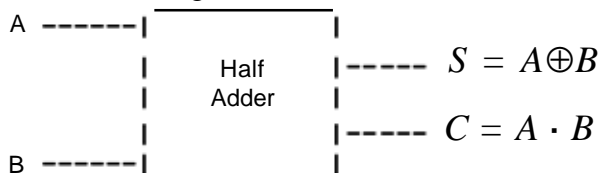

Figure.1.16

### FULLADDER

A full adder can be implemented in many different ways such as with a custom transistor-level circuit or composed of other gates. One example implementation is with  $S = A \oplus B \oplus C_{in}$  and  $C_{out} = (A \cdot B) + (C_{in} \cdot (A \oplus B))$ .

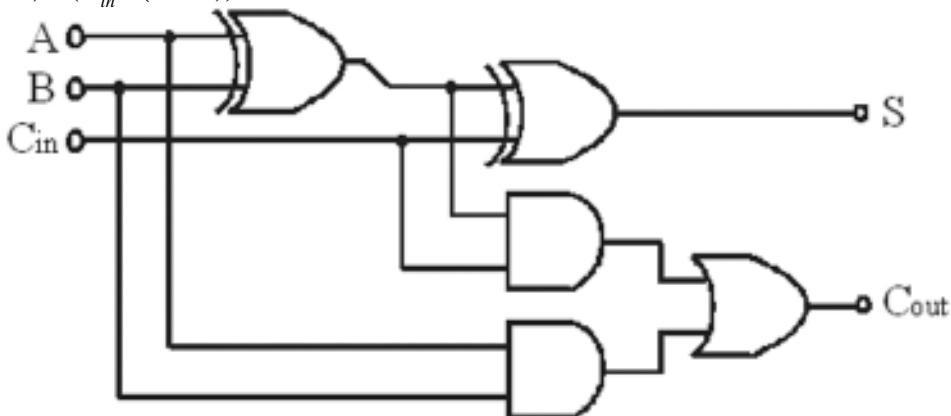

Figure.1.17 Example full adder circuit diagram

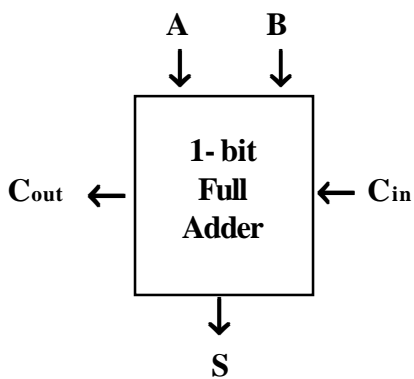

Figure.1.18 Full adder

Inputs			Outputs	
A	B	C <sub>i</sub>	C <sub>o</sub>	S
0	0	0	0	0
1	0	0	0	1
0	1	0	0	1
1	1	0	1	0
0	0	1	0	1
1	0	1	1	0
0	1	1	1	0
1	1	1	1	1

## SUBTRACTOR

In electronics, a subtractor can be designed using the same approach as that of an adder. The binary subtraction process is summarized below. As with an adder, in the general case of calculations on multi-bit numbers, three bits are involved in performing the subtraction for each bit of the difference: the minuend ( $X_i$ ), subtrahend ( $Y_i$ ), and a borrow in from the previous (less significant) bit order position ( $B_i$ ). The outputs are the difference bit ( $D_i$ ) and borrow bit  $B_{i+1}$ .

$$D_i = X_i \oplus Y_i \oplus B_i$$

K-map  $B_i(1,2,3,7)$

## HALF SUBTRACTOR

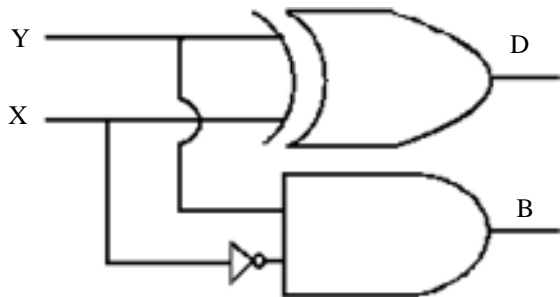

X	Y	D	B
0	0	0	0
0	1	1	1
1	0	1	0
1	1	0	0

Figure.1.18 Logic diagram for a half subtractor

Truth table

The half-subtractor is a combinational circuit which is used to perform subtraction of two bits. It has two inputs, X (minuend) and Y (subtrahend) and two outputs D (difference) and B (borrow).

## FULL SUBTRACTOR

The Full subtractor is a combinational circuit which is used to perform subtraction of three bits. It has three inputs, X (minuend) and Y (subtrahend) and Z (subtrahend) and two outputs D (difference) and B (borrow).

The truth table for the full subtractor is given below.

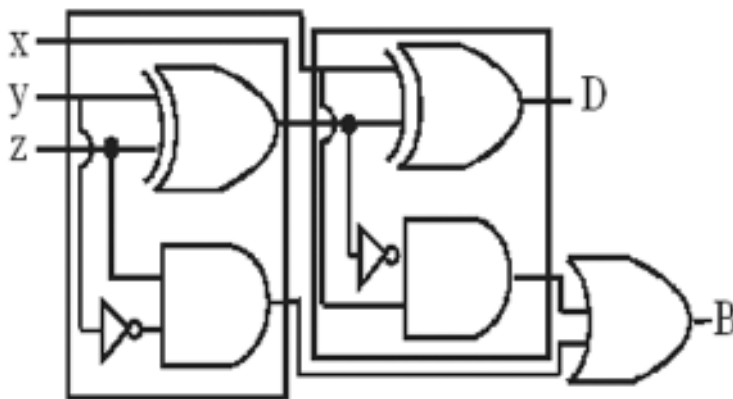

Figure.1.19

So, Logic equations are:

$$D = X \oplus Y \oplus Z$$

$$B = Z \cdot (\overline{X} \oplus \overline{Y}) + \overline{X} \cdot Y$$

X	Y	Z	D	B
0	0	0	0	0
0	0	1	1	1
0	1	0	1	1
0	1	1	0	1
1	0	0	1	0
1	0	1	0	0
1	1	0	0	0
1	1	1	1	1

Truth table

# 1.4 FLIP-FLOPS AND REGISTERS

## INTRODUCTION

In digital circuits, a flip-flop is a term referring to an electronic circuit (a bistable multivibrator) that has two stable states and thereby is capable of serving as one bit of memory. Today, the term flip-flop has come to mostly denote non-transparent (clocked or edge-triggered) devices, A flip-flop is usually controlled by one or two control signals and/or a gate or clock signal.

## IMPLEMENTATION

Flip-flops can be either simple (transparent) or clocked. Simple flip-flops can be built around a pair of cross-coupled inverting elements: vacuum tubes, bipolar transistors, field effect transistors, inverters, and inverting logic gates have all been used in practical circuits.

Clocked flip-flops are typically implemented as master–slave devices spikes and noise between the short clock transitions; they nevertheless also often include asynchronous *clear* or *set* inputs which may be used to change the current output independent of the clock

### RS (RESET-SET) FLIP-FLOP

An RS latch, constructed from a pair of cross-coupled NOR gates

Illustration of RS latch operation. Red and black mean logical '1' and '0', respectively.

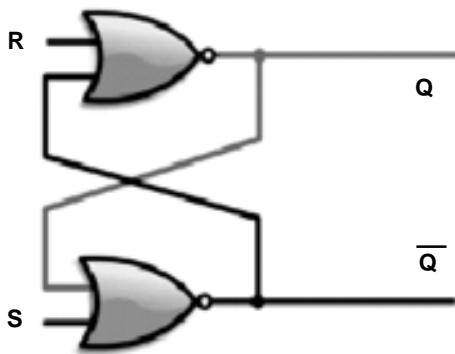

Figure.1.19

The fundamental latch is the simple *RS flip-flop* (also commonly known as *SR flip-flop*), where R and S stand for *reset* and *set*, respectively. It can be constructed from a pair of cross-coupled NAND or NOR logic gates. The stored bit is present on the output marked Q. Normally, in storage mode, the R and S inputs are both low, and feedback maintains the Q and Q outputs in a constant state, with Q the complement of Q. If S is pulsed high while R is held low, then the Q output is forced high, and stays high even after S returns low; similarly, if R is pulsed high while S is held low, then the Q output is forced low, and stays low even after R returns low.

S is held low, then the Q output is forced low, and stays low even after R returns low.

### D (DELAY) FLIP-FLOP

The D flip-flop is the most common flip-flop in use today. It is better known as *delay flip-flop* (as its output Q looks like a delay of input D) or *data latch*. The Q output takes on the state of the D input at the moment of a positive edge at the clock pin (or negative edge if the clock input is active low).

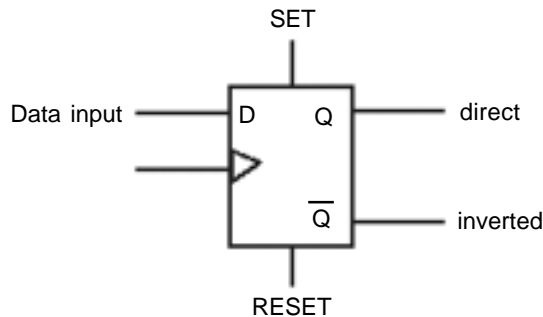

Figure.1.20 D flip-flop symbol

It is called the **D** flip-flop for this reason, since the output takes the value of the **D** input or *Data* input, and *Delays* it by maximum one clock count. The D flip-flop can be interpreted as a primitive memory cell, zero-order hold, or delay line. Whenever the clock pulses, the value of  $Q_{next}$  is D and  $Q_{prev}$  otherwise.

## T (TOGGLE) FLIP-FLOP

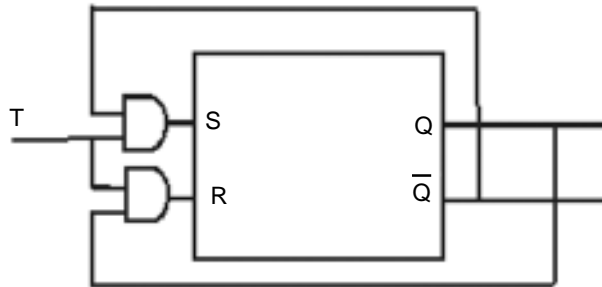

Figure.1.21 A circuit symbol for a T-type flip-flop, where  $\Delta$  is the clock input, T is the toggle input and Q is the stored data output

If the T input is high, the T flip-flop changes state (“toggles”) whenever the clock input is strobed. If the T input is low, the flip-flop holds the previous value. This behavior is described by the truth table:

### Uses

- A single flip-flop can be used to store one bit, or binary digit, of data. See preset.
- Any one of the flip-flop type can be used to build any of the others.

## REGISTERS

Register is a small amount of storage. In digital circuits, a shift register is a cascade of flip flops, sharing the same clock, which has the output of any one but the last flip-flop connected to the “data” input of the next one in the chain,

## 1.5 COUNTERS

A **counter** is a device which stores (and sometimes displays) the number of times a particular event or process has occurred, often in relationship to a clock signal. In practice, there are two types of counters:

- Up counters, which increase (increment) in value
- Down counters, which decrease (decrement) in value

Counters can be implemented quite easily using register-type circuits such as the flip-flop, and a wide variety of designs exist, e.g.:

- Asynchronous (ripple) counter
- Synchronous counter
- Decade counter
- Ring counter
- Johnson counter
- Cascaded counter

Each is useful for different applications. Usually, counter circuits are digital in nature, and count in natural binary. Many types of counter circuit are available as digital building blocks.

## ASYNCHRONOUS (RIPPLE) COUNTER

An asynchronous (ripple) counter is a single D-type flip-flop, with its D (data) input fed from its own inverted output. This circuit can store one bit, and hence can count from zero to one.



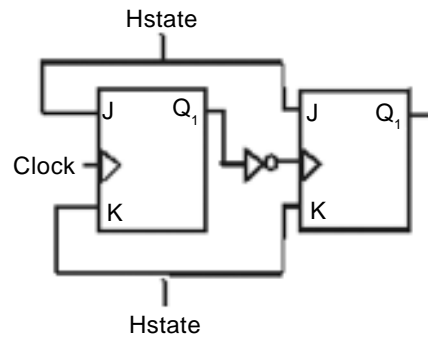

Figure. 1.22 Asynchronous counter created from two JK flip-flops

## RING COUNTER

A ring counter is a shift register (a cascade connection of flip-flops) with the output of the last one connected to the input of the first, that is, in a ring.

## JOHNSON COUNTER

A Johnson counter (or switchtail ring counter, twisted-ring counter, walking-ring counter, or Moebius counter) is a modified ring counter, where the output from the last stage is inverted and fed back as input to the first stage.

## DECADE COUNTER

A decade counter is one that counts in decimal digits, rather than binary.

A decimal counter may have each digit binary encoded (that is, it may count in binary-coded decimal).

The decade counter is also known as a mod-counter.

## UP-DOWN COUNTER

A counter that can change state in either direction, under the control of an up-down selector input, is known as an up-down counter. When the selector is in the up state, the counter increments its value; when the selector is in the down state, the counter decrements the count.

## ENCODER

An **encoder** is a device that converts information from one format or code to another.

## DECODER

A decoder is a multiple-input, multiple-output logic circuit that converts coded inputs into coded outputs, where the input and output codes are different.

## MULTIPLEXERS

A **multiplexer** or **mux** is a device that performs multiplexing; it selects one of many analog or digital input signals and forwards the selected input into a single line. A multiplexer of  $2^n$  inputs has  $n$  select lines, which are used to select which input line to send to the output to share one device or resource, for example one A/D converter or one communication line, instead of having one device per input signal.

On the other end, a demultiplexer (or **demux**) is a device taking a single input signal and selecting one of many data-output-lines, which is connected to the single input. A multiplexer is often used with a complementary demultiplexer on the receiving end.

An electronic multiplexer can be considered as a multiple-input, single-output switch, and a demultiplexer as a single-input, multiple-output switch. The schematic symbol for a multiplexer is an isosceles trapezoid with the longer parallel side containing the input pins and the short parallel side containing the output pin. The schematic on the right shows a 2-to-1 multiplexer on the left and an equivalent switch on the right. The sel wire connects the desired input to the output.

In telecommunications, a multiplexer is a device that combines several input information signals into one output signal, which carries several communication channels, by means of some multiplex technique. A demultiplexer is in this context a device taking a single input signal that carries many channels and separates those over multiple output signals.

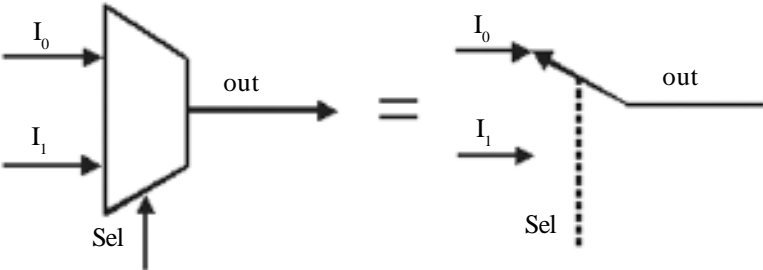

Figure.1.22 2 to 1 Multiplexer

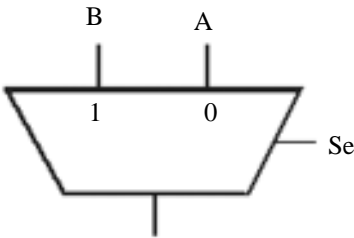

Figure.1.23 A 2-to-1 mux

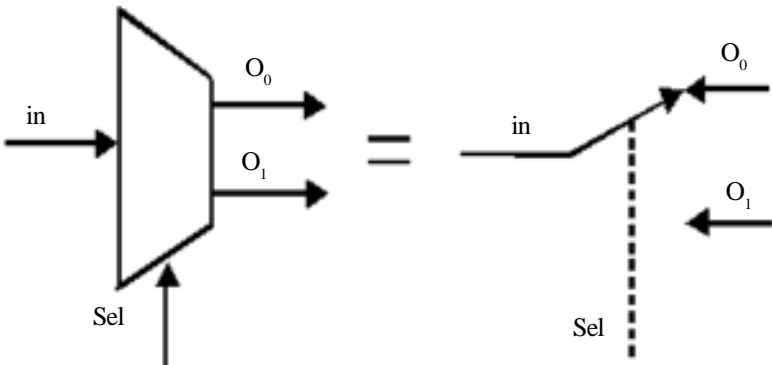

Figure.1.24 Demultiplexer

Truth Table

S	A	B	Z
0	1	1	1
	1	0	1
	0	1	0
	0	0	0
1	1	1	1
	1	0	0
	0	1	1
	0	0	0

In telecommunications and signal processing, an analog time division multiplexer (TDM) may take several samples of separate analogue signals and combine them into one pulse amplitude modulated (PAM) wide-band analogue signal. Alternatively, a digital TDM multiplexer may combine a limited number of constant bit rate digital data streams into one data stream of a higher data rate, by forming data frames consisting of one timeslot per channel.

This truth table shows that when  $S=0$  then  $Z=A$  but when  $S=1$  then  $Z=B$ . A straightforward realization of this 2-to-1 multiplexer would need 2 AND gates, an OR gate, and a NOT gate.

**DEMULTIPLEXERS**

Demultiplexers take one data input and a number of selection inputs, and they have several outputs. They forward the data input to one of the outputs depending on the values of the selection

inputs. Demultiplexers are sometimes convenient for designing general purpose logic, because if the demultiplexer's input is always true, the demultiplexer acts as a decoder. This means that any function of the selection bits can be constructed by logically OR-ing the correct set of outputs.

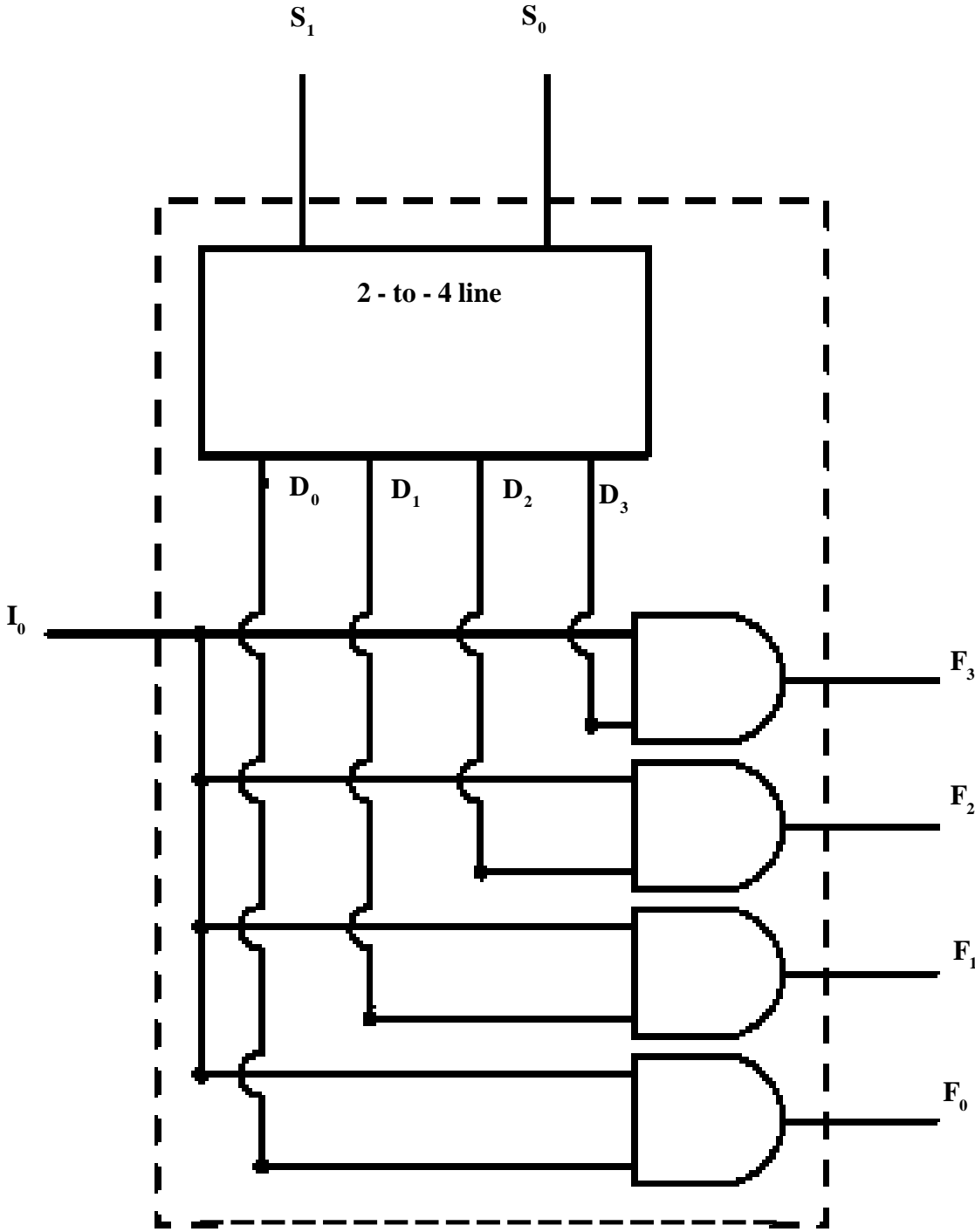

Figure.1.25 A Single Bit 1-to-4 Line Demultiplexer

## QUESTIONS

### I. CHOOSE THE BEST ANSWER

- Multi Vibrator is an \_\_\_\_\_ used to implement a variety of simple two state systems.  
a) Electronic Circuit                      b) Electrical Circuit  
c) Logical Circuit                         d) Arithmetic Circuit
- The \_\_\_\_\_ IC is an integrated circuit implementing a variety of timer and multivibrator applications.  
a) 666                                      b) 777                                      c) 810                                      d) 555
- In \_\_\_\_\_ mode the 555 timer acts as basic flip flop  
a) Astable                      b) monostable                      c) bistable                      d) Stable state
- A \_\_\_\_\_ table is a good way to show the functions of logic gate.  
a) true                                      b) True , False                      c) Common                      d) big
- NOT gate is also called an \_\_\_\_\_  
a) Rectifier                      b) inverter                      c) Converter                      d) Modulator
- A NAND Gate can have \_\_\_\_\_ or \_\_\_\_\_ inputs  
a) one, more                      b) Three, more                      c) Five, more                      d) two, more
- A \_\_\_\_\_ is a logical circuit that performs an addition operation on three one bit binary numbers.  
a) Half Adder                      b) Full Adder                      c) Inverter                      d) Rectifier
- An \_\_\_\_\_ is a device that converts information from one format or code to another.  
a) encoder                      b) Decoder                      c) Rectifier                      d) Inverter
- A \_\_\_\_\_ is a multiple input, multiple output logic circuit.  
a) encoder                      b) Inverter                      c) Decoder                      d) Rectifier
- A \_\_\_\_\_ is a device which stores the number of times a particular event or process has occurred.  
a) Counter                      b) Decoder                      c) Encoder                      d) Register

### II. ANSWER IN ONE OR TWO WORDS.

- State three types of Multi Vibrators.
- State two series symbols for logic gates.
- Define 'NOT Gate'.
- What is the function of Half Adder?
- Define Subtractor.

### III. ANSWER ONE OR TWO LINES.

- Define AND gate.
- Define NAND gate.
- Define NOR gate.
- Define Full Adder.
- Define Flip-Flop.

### IV. ANSWER ABOUT ONE PAGE

- Explain
  - Astable Multi Vibrator
  - Monostable Multi Vibrator

2. Explain
  - 1) Full Adder, Subtractor
  - 2) Asynchronous Counter, Up-Down Counter
3. Explain
  - 1) Decoder, Encoder
  - 2) RS Flip-flop, D Flip-flop

**V. ANSWER BRIEFLY :**

1. Explain the functions of Logic gates with neat diagrams.
2. Explain the functions of Half Adder and Full Adder with neat diagrams.

1) a    2) d    3) c    4) a    5) b    6) d    7) a    8) a    9) c    10) a

## **2. NETWORK ANTENNA AND PROPAGATION**

### **2.1 INTRODUCTION**

People have always had the desire to communicate their ideas to others. Communications have not only been desired from a social point of view, but have been an essential element in the building of civilization. Through communications, people have been able to share ideas of mutual benefit to all mankind. Early attempts to maintain communications between distance sound would carry and the difficulty of hand-carrying messages over great distances hampered effective communications.

As the potential for the uses of electricity were explored. Scientists in the United States and England worked to develop the telegraph. The first practical system was established in London, England, in 1838. Just 20 years later, the final link to connect the major countries with electrical communications was completed. The telegraph key, wire lines, use Morse code made possible almost instantaneous communications between points at great distances. Submarine cables solved the problems of transoceanic communications, but communications with ship at sea and mobile forces were still poor. In 1897 Marconi demonstrated the first practical wireless transmitter. He sent and received messages over a distance of 8 miles. By 1898 he had demonstrated the usefulness of wireless telegraph communications at sea. In 1899 he established a wireless telegraphic link across the English channel. His company also established general usage of the wireless telegraph between coastal light ships (floating lighthouses) and land. The first successful transatlantic transmissions were achieved in 1902. from that time to the present, radio communication has grown at an extraordinary rate. Early systems transmitter a few words per minute with doubtful reliability. Today, communications systems reliably transmit information across millions of miles.

The desire to communicate directly by voice, at a higher rate of speed than possible through basic telegraphy, led to further research. That research led to the development of MODULATION. Modulation is the ability to impress intelligence upon a TRANSMISSION MEDIUM, such as radio waves. A transmission medium can be described as light, smoke, sound wire lines or radio-frequency waves. To modulate is to impress the characteristics (intelligence) of one waveform onto a second wave from by varying the amplitude frequency, phase or other characteristics of the second waveform.

#### **2.1.1 MODULATION**

##### **NECESSITY OF MODULATION**

The signal wave in air can travel only a short distance because.

1. When the signal travels in air, its extensity goes down. (damping)
2. The frequency of the signal waves is very small

But the carrier wave can travel up to infinite distance. Therefore the Transmission of intelligence (voice and video signals) is done by sending the message on a carrier. So the signal wave is superimposed on carrier wave and then transmitted in the space. The process of superimposing (mixing) signal wave on the carrier wave is called modulation.

In this way, a transmitter includes and oscillator, signal producer and a modulator. Oscillator is used to produce carrier wave and the signal producer is used to produce signal wave and the modulator is used to produce modulated wave.

## TYPES OF MODULATION

The principal methods of modulation are as follows

1. Amplitude Modulation (AM)
2. Frequency Modulation (FM)
3. Phase Modulation (PM)

### AMPLITUDE MODULATION

The process of modulation in which the amplitude of carrier wave is varied in accordance with the amplitude of signal wave is called Amplitude modulation. It is used in radio and television communications. In this modulation, the frequency of carrier wave is constant. Its bandwidth is low.

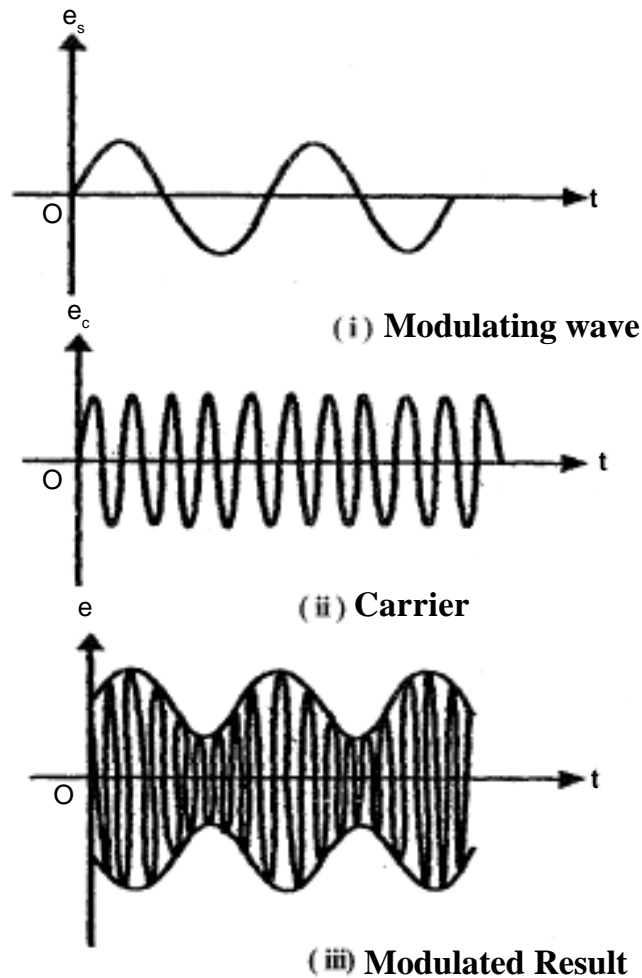

Fig.2.1.1 Amplitude Modulation  
(i) signal (ii) carrier (iii) modulated wave

### FREQUENCY MODULATION

The process of modulation in which the frequency of carrier wave is varied in accordance with the amplitude of signal wave is called frequency modulation. In this modulation, the amplitude of carrier wave is constant. It is used in micro wave communication. Its bandwidth is high.

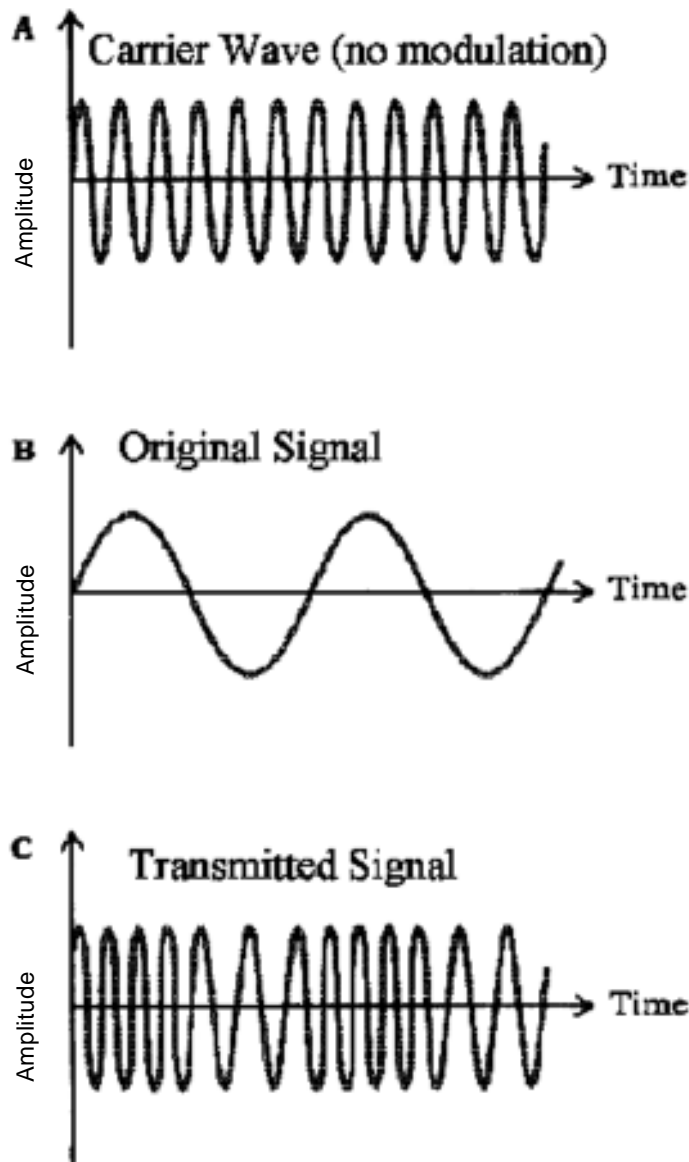

Fig.2.1.1 (b) Frequency modulation  
 (i)signal (ii)carrier (iii)modulated wave

## PHASE MODULATION

The process of modulation in which the phase (pulse-time) of the carrier waves varied in accordance with the signal wave is called phase modulation. It is used in remote control system.

## MODULATION NATURES

### PERCENTAGE OF MODULATION

The strength of audio signal at the receiver depends upon the depth of signal wave. The depth of modulation expressed in terms of percentage in known as percentage of modulation. It is the ratio between signal voltage and the carrier voltage.

$$\text{Percentage of Modulation} = \frac{\text{Signal Voltage}}{\text{Carrier Voltage}} \times 100$$



## **MODULATION INDEX**

In frequency modulation, the depth of modulation depends on the frequency deviation. In this way, the depth of frequency modulation is called modulation index. It is also known as modulation factor.

$$\text{Modulation index} = \frac{\text{Frequency deviation}}{\text{Signal frequency}}$$

### **2.1.2 MODEM**

Modem short for modulator – demodulator is an electronic device that converts a computer’s digital signals into specific frequencies to travel over telephone or cable television lines. At the destination the receiving modem demodulates the frequencies back in to digital data. Computers use modems to communicate with one another over a network.

The modem has significantly evolved since the 1970s when the 300 baud modem was used for connecting computers to bulletin board systems (BBSs).

While the 300 baud modem could transmit about 30 characters per second. People were soon sharing programs and graphics.

The designation asymmetric simply means that the modem is faster at downloading (getting data), than uploading (sending data). The ADSL modem has significant, immediate advantages over the dial-up modem. ADSL service is an “always on” connection, the ADSL modem is far faster than a dial-up modem.

Some business requires upload large files or programs to the internet, as well as download large files. For equal bandwidth in both directions, one would need a symmetric DSL (SDSL) account.

Yet another type of modem uses cable TV wiring rather than the phone line to provide internet connectivity. A cable modem requires service from a cable TV provider for internet connectivity.

A less common modem is a satellite modem or sat modem. The satellite modem converts digital data into radio waves to communicate with a satellite dish. But the service is more expensive than more conventional types of internet connectivity. A satellite modem can be an option for businesses or cable service offerings.

## **2.2 PULSE MODULATION**

A system of modulation in which the amplitude, duration, position may be so controlled as to represent the message to be communicated.

Varying the amplitude, polarity, presence or absence, duration of the pulses gives rise to the four basic forms of pulse modulation: pulse-amplitude modulation (PAM), pulse – code modulation (PCM), pulse-width modulation (PWM, also known as pulse – duration modulation (PDM) and pulse – position modulation (PPM).

## **ANALOG-TO-DIGITAL CONVERSION**

An important concept in pulse modulation is analog – to – digital (A/D) conversion. An inverse digital- to- analog (D/A) process is used at the receiver to reconstruct an approximation of the original form. Conceptually, analog – to- digital conversion involves two steps. First, the range of amplitudes is divided into a finite number of predetermined levels, and each such level is represented by a pulse of

fixed amplitude. Second, the amplitude of  $s(t)$  is periodically measured and replaced by the pulse representing the level that corresponds to the measurement, see also analog-to-digital converter; Digital-to-analog converter.

### 2.2.1 PULSE-AMPLITUDE MODULATION

In most practical systems the pulse duration, known as the duty cycle, is limited to a fraction of the sampling interval. Such a restriction creates the possibility of interleaving during one sample interval one or more pulses derived from other PAM systems in a process known as time – division multiplexing (TDM).

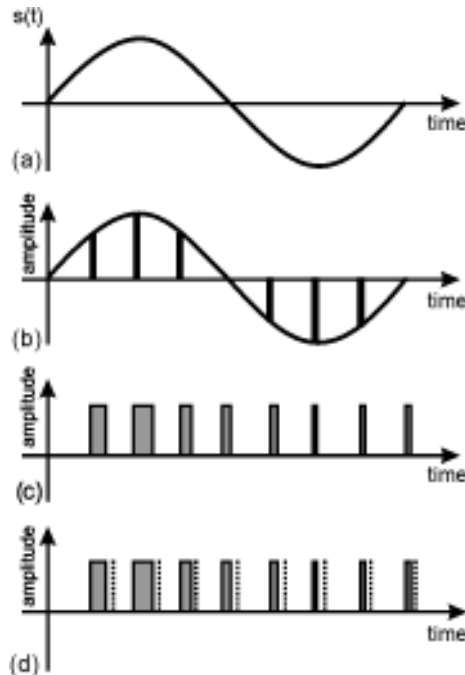

Figure 2.2.1 forms of pulse modulation

### 2.2.2 PULSE TIME MODULATION

Pulse time modulation (PTM) is a class of signaling technique that encodes the sample values of an analog signal onto the time axis of a digital signal.

The two main types of pulse time modulation are:

1. Pulse width modulation (PWM)
2. Pulse position modulation (PPM)

### 2.2.3 PULSE WIDTH MODULATION

In PWD the pulses representing successive sample values constant amplitudes but vary in time duration in direct proportion to the sample value. The pulse duration can be changed relative to fixed leading or trailing time edges or a fixed pulse centre. To allow for time-division multiplexing, the maximum pulse duration may be limited to a fraction of the time between samples.

### 2.2.4 PULSE - POSITION MODULATION

PPM encodes the sample values by varying the position of a pulse of constant duration relative to its nominal time of occurrence. As in PAM and PWM, the duration of the pulses is typically a fraction of the sampling interval. In addition, the maximum time excursion of the pulses may be limited.

## 2.3 PULSE DIGITAL MODULATION

Pulse digital modulation is the modulation technique which converts the analog signal into digital. PCM comes under pulse digital modulation where we discretize both time and amplitude. Discretizing time, as we know is called sampling. Discretizing amplitude is called 'quantizing'. Quantizing involves conversion of analog signal amplitude to discrete amplitude.

### 2.3.1 PULSE-CODE MODULATION

Many modern communication systems are designed to transmit and receive only pulses of two distinct amplitudes. In these so called binary digital systems, the analog- to-digital conversion process is extended by the additional step of coding, in which the amplitude of each pulse representing a quantized sample is converted into a unique sequence of one or more pulses with just two possible amplitudes. The complete conversion process is known as pulse-code modulation.

Figure 2.2. 1a shows the example of three successive quantized samples of an analog signal.

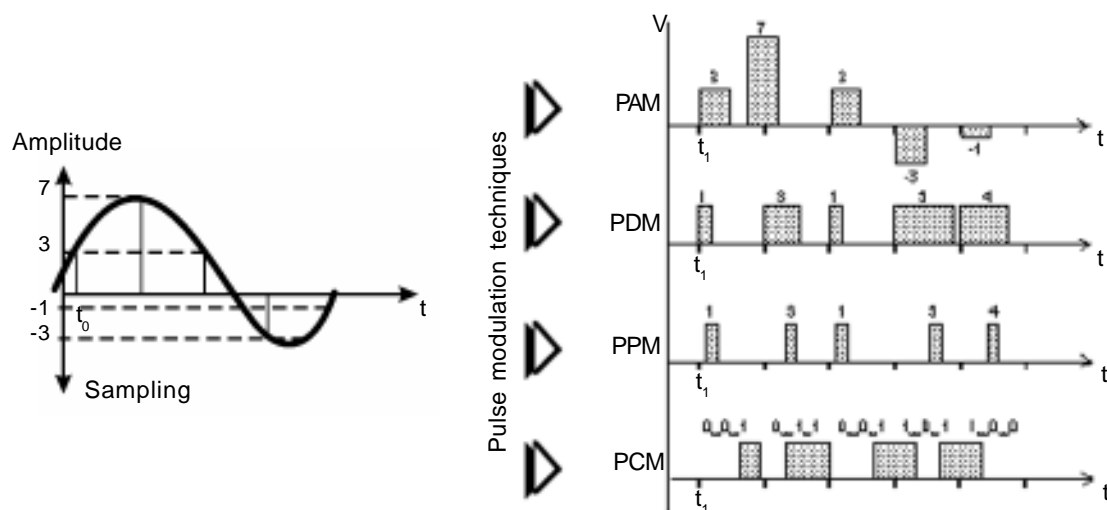

Fig. 2.3.1 Pulse-code modulation. 2 (a) three successive quantized samples of an analog signal. (b) With pulses of amplitude V or 0. (c) with pulses of amplitude V or -V.

PCM enjoys many important advantages over other forms of pulse modulation due to the fact that information is represented by a two-state variable. First, the design parameters of a PCM transmission system depend critically on the bandwidth of the original signal. Second, the detection of the state of a two-state variable in a noisy environment is inherently simpler. Third, the binary pulses propagating along a medium can be intercepted at a point. New pulses can then be generated and transmitted to the next such decoding point. This so called process of repeater significantly reduces the propagation of distortion and leads to a quality of transmission that is largely independent of distance.

### TIME-DIVISION MULTIPLEXING

An advantage inherent in all pulse modulation systems is transmit signals over a common transmission system through the process of time-division multiplexing.

### BANDWIDTH REQUIREMENTS

Pulse modulation systems may incur a significant bandwidth penalty compared to the transmission of a signal in its analog form. An example is the standard transmission of an analog voice signal band-limited to 4000hertz over a TI carrier.

## **APPLICATIONS**

PAM, PWM and PPM found significant application early in the development of digital communications.

Transmission systems use some form of time-division multiplexing.

The high speed networks such as the integrated service digital network (ISDN) has also relied heavily on PCM technology. PCM and various modified forms such as delta modulation (DM) and pulse code modulation (ADPCM) have also found significant application in satellite transmission systems.

### **2.4 MICROWAVE TRANSMISSION**

Microwave transmission refers to the technology of transmitting information by the use of the radio waves whose wavelengths are conveniently measured in small numbers of centimeters, by using various electronic technologies. These are called microwaves. This part of the radio spectrum ranges across frequencies of roughly 1.0 gigahertz (GHz) to 30GHz. Also by using the formula  $\lambda = c/f$ . [in the above equation, the Greek letter ( $\lambda$ ) is the wavelength in meters; c is the speed of light in meters per second; and f is the frequency in hertz (Hz)]

In the microwave frequency band, antennas are usually of convenient sizes and shapes, and also the use of metal waveguides for carrying the radio power works well. Furthermore with the use of the modern solid state electronics and travelling wave tube technologies that have been developed since the early 1960's, the electronics used by microwave radio transmission have been readily used by expert electronics engineers.

Microwave radio transmission is commonly used by communication systems on the surface of the earth, in satellite communications, and in deep space radio communications. Other parts of the microwave radio band are used for radars, radio navigation systems, sensor systems and radio astronomy.

### **PROPERTIES**

- Suitable over line- of-sight transmission links without obstacles
- Provides good bandwidth
- Affected by rain, vapor, dust, snow, cloud, mist and fog, heavy moisture, depending on chosen frequency.

### **USES**

- Backbone carriers in cellular networks.
- Communication with satellite
- Microwave radio relay links for television and telephone service providers.

### **2.5 ANTENNA-INTRODUCTION**

An antenna (or aerial) is a transducer that transmits or receives electromagnetic waves. In other words, antennas convert electromagnetic radiation into electrical current, or vice versa. Antennas generally deal in the transmission and reception of radio waves, and are a necessary part of all radio equipment. Antennas are used in systems such as radio and television broadcasting, point-to-point radio communication, wireless LAN, cell phones, radar, and spacecraft communication. Antennas are most commonly employed in air or outer space, but can also be operated under water or even through soil.

Physically an antenna is an arrangement of one or more conductors, usually called elements. In transmission an altering current is created in the elements by applying a voltage at the antenna terminals,

causing the elements to radiate an electromagnetic field. In reception the inverse occurs: an electromagnetic field from another source induces an alternating current in the elements and a corresponding voltage at the antenna's terminals. Some receiving antennas (such as parabolic and horn types) incorporate shaped reflective surfaces to collect the radio waves striking them and direct or focus them onto the actual conductive elements.

A common antenna is a vertical rod a quarter of a wavelength long. Such antennas are simple in construction, usually inexpensive, and both radiate in and receive from all horizontal directions (omnidirectional). One limitation of this antenna is that it does not radiate or receive in the direction in which the rod points. This region is called the antenna blind cone or null.

There are two fundamental types of antenna directional patterns, which with reference to a specific to dimensional plane (usually horizontal [parallel to the ground] or vertical [perpendicular to the ground]) are either,

1. Omni-directional (radiates equally in all directions), such as a vertical rod (in the horizontal plane) or
2. Directional (radiates more in one direction than in the other)

### **2.5.1 TRANSMITTING ANTENNA TYPES**

There are many variations of antennas. Below are a few basic models

- The isotropic radiator is a purely theoretical antenna that radiates equally in all directions. It is considered to be a point in space with no dimensions and no mass. This antenna cannot physically exist, but is useful as a theoretical model for comparison with all other antennas. Most antennas gains are measured with reference to an isotropic radiator, and are rated in dBi (decibels with respect to an isotropic radiator)
- The dipole antenna is simply two wires pointed in opposite directions arranged either horizontally or vertically, with one end of each wire connected to the radio and the other end hanging free in space. Since this is the simplest practical antenna, it is also used as a reference model for other antennas; gain with respect to a dipole is labeled as dBd. Generally, the dipole is considered to be omni directional in the plane perpendicular to the axis of the antenna. But it has deep nulls in the directions of the axis. Variations of the dipole include the folded dipole, the half wave antenna, the ground plane antenna, the whip, and the J-pole.
- The Yagi- Uda antenna is a directional variation of the dipole with parasitic elements added which are functionally similar to adding a reflector and lenses (directors)
- The random wire antenna is simply a very long (at least one quarter wavelength) wire with one end connected to the radio and the other in free space, arranged in any way most convenient for the space available. Folding will reduce effectiveness. Typically a random wire antenna will also require an antenna tuner, as it might have a random impedance that varies non-linearly with frequency.
- The horn is used where high gain is needed, the wavelength is short (microwave) and space is not an issue. Horns can be narrow band or wide band, depending on their shape. A horn can be built for any frequency but horns for lower frequencies are typically impractical. Horns are also frequently used as reference antennas.

- The parabolic antenna consists of an active element at the focus of a parabolic reflector to reflect the waves into a plane wave. Like the horn it is used for high gain, microwave applications, such as satellite dishes.
- The patch antenna consists mainly of a square conductor mounted over a ground plane. Another example of a planar antenna is the tapered slot antenna (TSA), as the Vivaldi antenna.

## **2.6 RECEIVING**

### **ANTENNA**

An instrument is necessary to couple the transmitted RF waves and the receiver.

The received signal is processed to various actions and finally audio is obtained. For this an antenna is needed.

In transmitters also, it is necessary to transmit the RF waves to space. Thus an antenna couples the transmitter and receiver.

Antenna is a lengthy rod which transforms energy, one form to another. If it is a transmitting antenna, electrical signals are converted into electromagnetic waves while if it is a receiving antenna, electromagnetic waves are converted into electrical signal.

In radar one antenna can act as both transmitting and receiving antennas. The characteristics of an antenna is referred as its reciprocity.

### **NECESSITIES OF AN ANTENNA**

1. It receives the desired signals and should induce necessary signal voltage
2. It should separate the desired signals from the unwanted signals
3. Should receive large bandwidth; it should be rotatable to receive signals from various stations.

### **CHARACTERISTICS OF AN ANTENNA**

1. Directivity
2. Gain
3. Bandwidth
4. Impedance

### **DIRECTIVITY**

The character of an antenna that receives more signals is referred as directivity

### **GAIN**

The character of an antenna, that gives more signal strength, is referred as gain. It depends upon directivity.

### **BANDWIDTH**

The range of frequencies of signal which can be received by an antenna efficiently is called as bandwidth.

### **IMPEDANCE**

The ratio between the voltage obtained from full length of an antenna and current as impedance

## **TYPES OF RECEIVING ANTENNA**

Under indoor antenna classified into two types

1. Indoor antenna
2. Outdoor antenna

### **INDOOR ANTENNA**

Under indoor antenna few types are there

1. V type antenna
2. Door frame type antenna
3. Inbuilt antenna

### **OUTDOOR ANTENNA TYPES**

1. Dipole antenna
2. Folded dipole antenna
3. Reflector dipole antenna
4. Yagi antenna

### **DIPOLE ANTENNA**

This type is made up of two pieces of aluminum poles. Hence this type of antenna is called Dipole antenna. Assume the length of this dipole antenna is 7.4 feet. This antenna is capable of attracting the signals corresponding to it.

But in the middle portion, voltage and current are high. Hence the transmission cable is connected in this portion and taken to the TV receiver. The gain received through this antenna is very minimum, hence it is modified.

### **FOLDER DI-POLE ANTENNA**

In this, a pole which is double the length of the di-pole is taken and folded making equal to the length of di-pole. Since this structure is double as like the di-pole antenna, it is capable of absorbing more signals. The gain received through this antenna is double as of the di-pole antenna. Hence this type of antenna is used by the people bit far away from the transmitter.

### **REFLECTOR DI-POLE ANTENNA**

This type of antenna is used at the distance of more than 50km from the transmitter. In this, along with the folded di-pole, an yet another pole which has bit more length than the di-pole is placed. This is called as Reflector, since it reflects the waves to the di-pole and creates magnetic flux in it. The distance between the di-pole and the reflector is  $\lambda/4$ . since the phase of this wave and the wave attracted by the di-pole are same. Hence this type of antenna is capable of giving more gain.

### **2.6.1 YAGI ANTENNA**

The fig shows the structure of yagi antenna. As like reflector and yet another piece of pole is added before the di-pole. The length of the new piece must be equal to the di-pole. This is termed as director. In the fig 'D' is the director. Assume that waves are coming from the direction of the arrow, the director is the first element to receive the waves. Now this antenna could able to generate three times

higher gain (director, folded di-pole, reflector) than the strength of other antenna. Hence the gain given by this antenna is very high and it is widely used even far away from the transmitter.

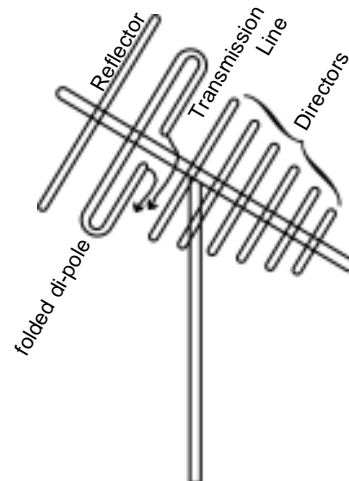

Fig.2.6.1 Yagi antenna

## 2.6.2 DISH ANTENNA

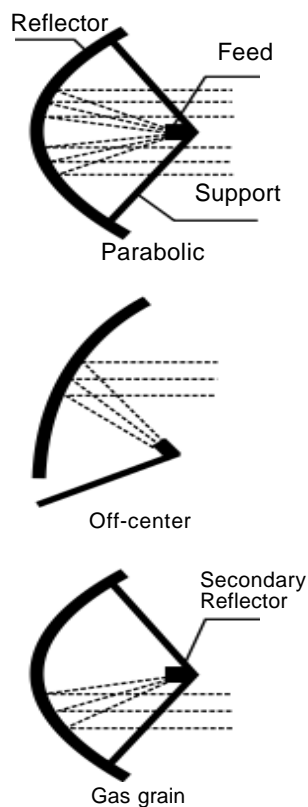

Fig.2.6.2 Main types of parabolic Antenna

The term dish antenna is often used for a parabolic antenna. A parabolic antenna is a high-gain reflector antenna used for radio, television and data communications, and also for radiolocation (radar), on the USF and SHF parts of the electromagnetic spectrum. The relatively short wavelength of electromagnetic radiation at these frequencies allows reasonably sized reflectors to exhibit the desired highly directional response for both receiving and transmitting.

Heinrich Hertz constructed the world's first parabolic reflector antenna in 1888. The antenna had an aperture 1.2 meters wide, a focal distance of 0.12 meters, and was used at operating frequency of about 450 MHz. The reflector was made of zinc sheet metal supported by a wooden frame, and had a spark-gap excited dipole along the focal line. With two such antennas, one used for transmitting and the other for receiving.

A typical parabolic antenna consists of a parabolic reflector with a small feed antenna at its focus. To find the focus, reflect the light of a flashlight off of the dish. When the reflected beam is parallel, the flashlight is at the focus.

The reflector is a metallic surface formed into a parabolic of revolution and in a circular rim that forms the diameter of the antenna. This paraboloid possesses a distinct focal point by virtue of having the reflective property.

The feed antenna at the reflector's focus is typically a low gain such as a half-wave dipole or a small waveguide horn. The feed antenna is connected to the associated radio frequency (RF) transmitting or receiving equipment by means of a coaxial cable transmission line or hollow waveguide.



Considering the parabolic antenna as a circular aperture gives the following approximation for the maximum gain:  $G \approx (\pi^2 D^2) / \lambda^2$  or  $G(\lambda)$

Where: G is power gain, D is reflector,  $\lambda$  is wavelength

### 2.6.3 LNB

An LNB sits on the end of an arm and face the parabolic reflector (“dish”) which focuses the signals from a satellite into the “feed horn” of the LNB.

The LNB converts the signals to a lower frequency and sends them out to the cable connector, which you connect to your satellite receiver via coaxial cable.



Fig. 2.6.3(a) LNB

#### LIST OF UNIVERSAL LNB'S

##### “UNIVERSAL” LNB 9.75 AND 10.60GHZ

Works in 2 bands

- 10.7 – 11.8 GHz and
- 11.6 – 12.7 GHz (22KHz signal switched)

Noise figure usually 1.0dB or better. It has an integral feed horn with 40mm neck available in some models.

A universal LNB requires a 22 KHz signal at 0.5v p-p to switch its local oscillator to 10.6GHz (“high band”). Otherwise it uses its 9.75GHz oscillator (“low band”).

Polarization switching is controlled by DC voltage supplied by the receiver. 12.5v to 14.5v gives vertical and 15.5 to 18v gives horizontal polarization.

A higher voltage than that may damage the LNB but most are OK up to 20v.

#### “TWIN-OUTPUT” LNB

The twin output LNB provides two outputs to feed two separate receivers for independent working. Each output can be switched independently by 13/7 volt input by the individual receiver to change polarization and by 22KHz to change the band.

#### “DUAL LNB” OR “MONOBLOCK LNB”

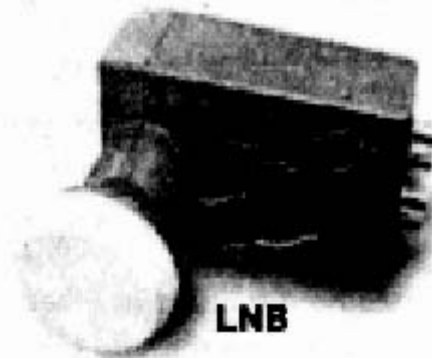

Fig2.6.3 (b) Dual LNB

This type of LNB has a single output and the actual satellite signal is selected by the receiver which sends a Dis EqC (22KHz) pulsed tone up the LNB cable. So only one satellite transmission can be viewed at a time.

## “QUAD – OUTPUT” OR “QUAD UNIVERSAL” LNB



**Fig2.6.3 (c) Quad-output LNB**

This can feed four separate receivers. Basically an LNB with four IF outputs. Each receiver has independent control of polarization and band via 13/17v switching and 22 KHz on/off respectively.

### “OCTO” LNB

As above but with eight independent outputs. You can then connect up to eight satellite receivers to a single dish.

### “QUATTRO UNIVERSAL LNB”

This has four fixed outputs and is used only in “head end” I.F distribution systems for apartment blocks.

One LNB supplies a head end unit that can provide (typically) up to 16 outputs for separate digiboxes.

The four outputs of the LNB are as follows:

1. Horizontal polarization low band
2. Horizontal polarization high band
3. Vertical polarization low band
4. Vertical polarization high band

## 2.6.4 SATELLITE RECEIVER

The standard digital satellite receiver can tune in only one program at a time and this program can be routed around the house for viewing in other rooms.

To assist in this, most satellite receivers have a RF output (RF Outlet) socket.

However you should note that you can only tune into and watch any one program at a time on all TV sets connected to a single receiver.

You can connect as many televisions as you like to one receiver, although they will all be watching the same channel.

One issue to be aware of is that you will only be able to change channels from the same room that the receiver is located in. Unless you purchase a unit with an UHF remote.

A satellite receiver must be connected to a land based telephone line 24/7 to view pay-per-view PPV movies, events and some sports packages. In some cases a full time connection is also required for multiple receiver installations.

The telephone line provides the satellite receiver the ability to communicate back to your satellite service provider.



Fig 2.6.4 Satellite Receiver

## QUESTIONS

### I. CHOOSE THE BEST ANSWER

1. Telegraphy key use \_\_\_\_\_ type of communication
  - a. wireless communication
  - b. morse code
  - c. Modulation
  - d. wire communication
2. The process of superimposing (mixing) signature on carrier wave is called \_\_\_\_\_
  - a. De-modulation
  - b. modem
  - c. modulation
  - d. pulse modulation
3. In frequency modulation carrier waves are varies in accordance with \_\_\_\_\_ of the signal wave.
  - a. Frequency
  - b. Phase
  - c. width
  - d. amplitude
4. 300 baud modem could transmit about \_\_\_\_\_ characters per second
  - a. 30
  - b. 300
  - c. 3
  - d. 3000
5. In \_\_\_\_\_ Is analog – to – digital conversion is made
  - a. pulse modulation
  - b. amplitude modulation
  - c. pulse – amplitude modulation
  - d. frequency modulation
6. The length of microwaves are in \_\_\_\_\_ Units.
  - a. centimeter
  - b. millimeter
  - c. meter
  - d. kilometer
7. The antenna gains one measured with reference to an \_\_\_\_\_
  - a. Di-pole antenna
  - b. Dish antenna
  - c. Isotopic antenna
  - d. Yagi antenna
8. Quad – output LNB has \_\_\_\_\_ outputs
  - a. 8
  - b. 4
  - c. 16
  - d. 2
9. A diameter of dish antenna is considered about its \_\_\_\_\_
  - a. inner parabolic diameter
  - b. outer para bolic diameter
  - c. circular rim diameter
  - d. inner diameter

10. A transmitter antenna converts \_\_\_\_\_ into electro magnetic wave.  
a. audio wave                      b. radio wave                      c. signal wave                      d. electrical wave

## II. ANSWER IN ONE OR TWO WORDS

1. What is the need of carrier wave?
2. Expand – ADSL
3. Which antenna is mounted on the earth surface?
4. Who built the antenna first?

## III. ANSWER IN FEW LINES

1. What is meant by modulation?
2. Say about the various kinds of modulation
3. Horn antenna write note
4. What is duol output LNB?
5. Name the elements of yagi antenna?
6. What are kinds of pulse – modulations
7. What is demodulation
8. Give a few words about modem.

## IV EXPLAIN ABOUT ONE PAGE

1. Write about the principle of modulation
2. Explain the amplitude modulation with wave form.
3. Explain with diagram of frequency modulation
4. De-modulation – explain
5. What are types of antenna?
6. Write about yagi antenna?

## V ANSWER BRIEFLY 20MARKS

1. What are the types of pulse modulation explain any four of them?
2. Write briefly about microwaves
3. Explain the types of transmitting antenna
4. Explain Dish antenna

**Ans:** 1(b) 2(c) 3(d) 4(a) 5(a) 6(a) 7(c) 8(b) 9(c) 10(d)

## **3. RADIO TRANSMISSION AND RECEPTION**

### **INTRODUCTION**

It is an instrument, which receives the radio signals from the broadcasting stations and produce sound. In 1895, Marconi succeeded in telecommunication, which is called as Radio communication. He proved the wireless communication in 1901.

The simplest radio receiver is the crystal receiver. It was made by Henrich Hertz in the year 1895. It was designed to work up to 50 Kilometers. Then, in the year 1909, the Tuned radio frequency receiver was made. Major Armstrong designed a different type of radio receiver in the year 1917. This receiver is known as Superheterodyne (shortly superhet) receiver. Its sensitivity and selectivity are high. All the modern radio receiver work under the principle of Superheterodyne. In USA, the first regular broadcast began in 1920. In India, first Radio station was established in 23<sup>rd</sup> July 1927 at Bombay.

### **BASIC PRINCIPLE**

The following principles are observed in all type of radio receivers.

#### **1. RECEPTION**

An aerial is necessary for the reception of radio waves. It connects the radio waves with the receiver.

#### **2. SELECTION**

It is the ability to select a desired radio station from various radio station. This work is performed by a LC resonant network.

#### **3. DETECTION**

In this process radio frequency signals are converted into audio frequency signals. It is performed by a crystal diode.

#### **4. REPRODUCTION**

The conversion of audio signal into sound is called reproduction. It is performed by a speaker.

### **ABILITIES OF RECEIVERS**

This quality and speciality of a radio receiver is determined on the basis of the following abilities.

#### **1. SENSITIVITY**

It is the ability to produce sufficient audio output even for weak input radio frequency signal. It depends on the R.F. and I.F. amplification capabilities.

#### **2. SELECTIVITY**

It is the ability to select only the desired signal or radio station, from the signals which are received by the aerial. It depends on accurate alignment of the tuned circuits. Hence converter and R.F. amplifier is designed to improve the selectivity. If selectivity increases, image frequency and adjacent channels interference of a receiver decreases.

### 3. FIDELITY

It is the ability to amplify the complete range of audio frequency without loss. It depends upon the design of AF amplifiers.

### 4. STABILITY

It is the ability to produce stable output without variation. AVC circuit is used to produce stability in the sound.

### 5. SIGNAL TO NOISE RADIO

It is the ratio between the signal and noise. A noise limiter stage is used to improve this ability.

## TYPES OF RADIO RECEIVER

Generally the Radio receivers are classified into the following two types.

1. TRF Radio receiver
2. Superhet Radio receiver

### TRF RADIO RECEIVER

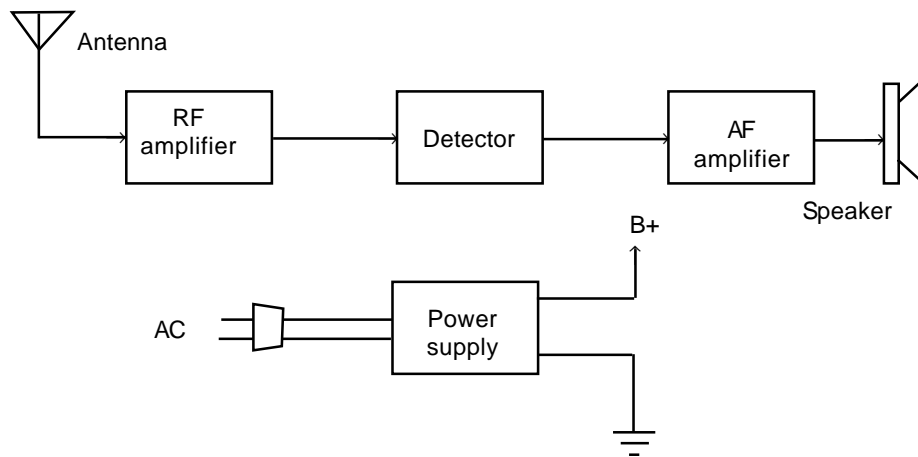

Fig. 3.1

It is a straight radio receiver. It is called as tuned radio frequency receiver. It has the following stages.

- |                 |                      |
|-----------------|----------------------|
| i) RF Amplifier | iii) Audio Amplifier |
| ii) Detector    | iv) Power supply     |

### RF AMPLIFIER

It is a tuned radio frequency amplifier. It amplifies the radio frequency signal which is selected by antenna.

### DETECTOR

It is used between the RF and IF amplifiers. It works as amplitude modulated detector. It will convert RF signals into AF signals. Crystal or signal diodes are used in it.

### AUDIO AMPLIFIER

It amplifies the strength of audio signals. It contains pre amplifier, driver and output amplifiers. The pre and driver amplifiers are voltage amplifiers. The output amplifier is power amplifier. The speaker converts audio signal into sound.

## POWER SUPPLY

It supply the required voltage to all stage of the receiver. Battery or battery eliminator is used as power supply.

## MERITS

1. It is a simple receiver.
2. Simple circuits are used
3. Alignment is not necessary

## DEMERITS

1. Sensitivity and Selectivity are low.
2. Poor fidelity
3. Low stability

## SUPERHET RADIO RECEIVER

This receiver works under the principle of heterodyning. Modern radio receivers are mostly of superheterodyne types. It is having converter stage which changes the incoming signal into intermediate frequency (IF) signals.

## GANGRED CAPACITORS

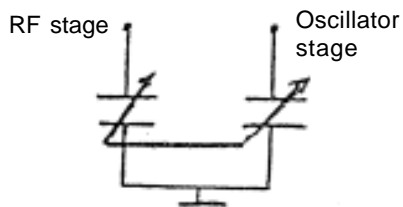

Fig.3.2.

If two variable capacitors are fitted in a common shaft, it is called as Ganged capacitors. One variable capacitor is used to select the desired Radio station at the RF stage and the other one is used in oscillator stage to produce the suitable oscillator frequency to the desired radio station.

## GANGED TUNNING

Selecting desired radio station Ganged capacitors is called as Ganged tuning.

## PRINCIPLE OF SUPERHET RECEIVER

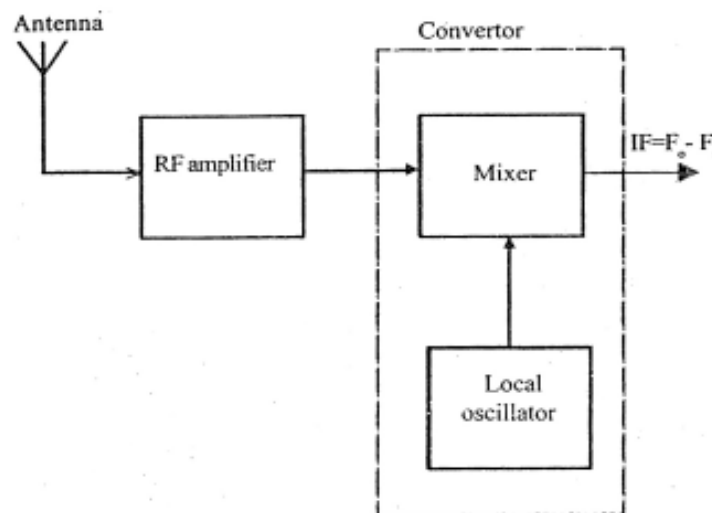

Fig.3.3

The process of beating (mixing) two different signals to produce new signal is called as Heterodying.

If two different signals are mixed through a transistor, four types of signals are obtained in the output of the transistor. They are.

1. First signal ( $F_o$ )
2. Second signal ( $F_s$ )
3. Addition of the two ( $F_o+F_s$ )
4. Difference between the two ( $F_o-F_s$ )

Apart from these, an unwanted signal called Harmonics is produced due to the mixing of the two signals. Out of them, the difference between the two is taken as Intermediate Frequency (IF) and the remaining signals are filtered. This is called as Principle of Superheterodying. The receivers which follow this principle is named as super bet receivers. This principle is used in AM, FM, Communication, Radar and Television receivers.

### **MERITS**

1. Good sensitivity and selectivity
2. Good fidelity
3. Good stability

### **DEMERITS**

1. It needs Alignment and tracking
2. Complicated circuits are used

### **INTERFERENCES IN SUPERHET RADIO RECEIVER**

Generally, Superhet receivers have better selectivity and sensitivity. But the following two interferences are occurred.

1. Image frequency
2. Adjacent channels interference.

### **IMAGE FREQUENCY AND METHOD OF REJECTING IT**

If two nearby radio station being received at a time, this defect is said to be image Frequency.

Rejecting image frequency depends upon the selectivity of RF stage. It should be rejected before IF stage. Once it enters IF stage, it cannot be eliminated.

### **ADJACENT CHANNEL INTERFERENCE**

In superhet receiver, when the bandwidth is reduced from required level, this type of interference is developed. When two different radio station are selected very closely, interference. To eliminate this, low IF signal should be selected. So, in superhet receivers, intermediate frequency (IF signal) is selected to avoid both the interferences. In double conversion receivers, these two interference are eliminated completely, because they use two different IF signals, one is high and the other is low. So a double conversion receiver should have two converters and two IF amplifiers.

### **3.3 AM RADIO RECEIVER**

A receiver which receives amplitude modulated radio signals is called amplitude modulated (AM) radio receiver.



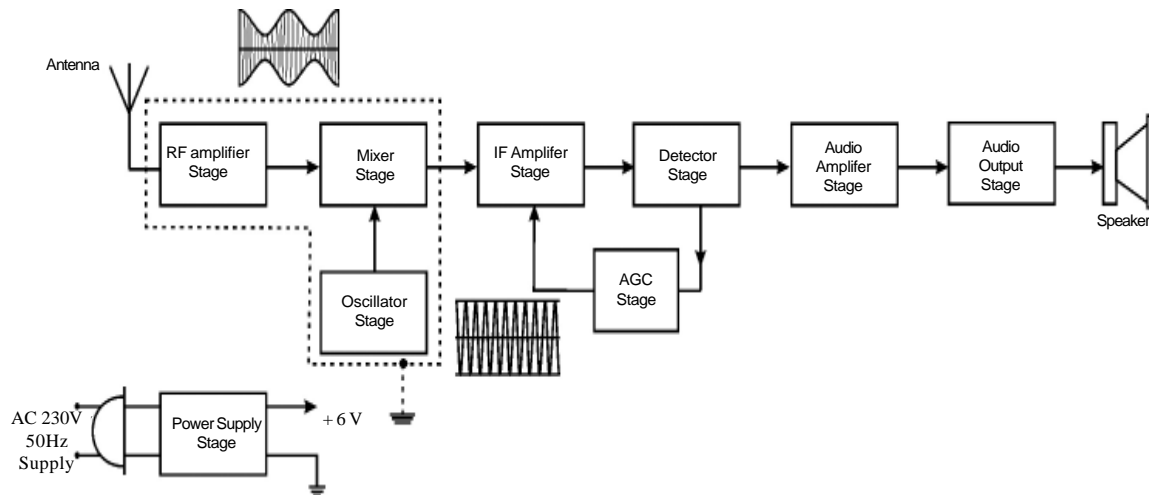

Fig. 3.4 Block diagram of AM radio receiver

It contains the following stages.

- |                  |                    |                 |
|------------------|--------------------|-----------------|
| 1. RF Amplifier  | 2. Converter       | 3. IF amplifier |
| 4. Detector, AVC | 5. Audio Amplifier | 6. Power Supply |

## RF AMPLIFIER

It consists of an aerial. The aerial receives the electromagnetic waves and convert them into RF electrical signals. This stage amplifies the RF signals obtained from the aerial. It's output signal is coupled with converter stage.

## CONVERTER

It is also known as first detector or frequency changer. It has mixer and local oscillator stages. The local oscillator produces unmodulated radio frequency signals. The mixer stage mixes the oscillator signal and RF signal. In the output of this stage intermediate frequency(IF) is selected. The value of IF signal is equal to the different of oscillator and signal frequencies ( $IF = F_o - F_s$ ).

## IF AMPLIFIER

It amplifiers the strength of IF signals to improve the senwsitivity. It is a transformer coupled amplifier. Its input has tuned circuit. IF transformers (IFT) are used in it. It employs one or two turned intermediate frequency amplifiers.

## DETECTOR

It is also known as demodulator or detector. The Signal diodes are used in this stage. It filters the carrier signal and separates the audio signal form the IF signal. AF signal to the audio stage

## AVC

It is an automatic volume control. It controls the volume of the receiver automatically.

## AUDIO AMPLIFIERS

This stage consists of voltage and power amplifiers. The voltage amplifier working as pre-amplifier and amplifier working as output amplifier. This stage amplifiers the voltage and power of audio signals. Hence the fidelity is improved by this stage. Push-pull amplifier is used as output amplifier.

The loud speaker converts the audio signals into sound.

## POWER SUPPLY

It is the first stage in the receiver. It works as a tuned radio frequency amplifier. So it is designed as transformer coupled amplifier.

## FUNCTIONS

- i) It amplifies the radio frequency signals from antenna.
- ii) It selects the desired radio station from various radio stations, and rejects all others unwanted signals.
- iii) It improves selectivity of the receiver.

## WORKING

In the circuit, BF 194 B(NPN) transistor is used as amplifier. Tuned transformers are connected in the input and output section, tuning condensers are with the transform windings. So the combination of coils and condensers server as tuned circuits. An antenna is connected with this tuned network.

The antenna converts electro magnetic waves into RF electrical signals. Then the desired signals are selected by the tuning condensers. Those signals are fed to the amplifier for amplification. The transistor gets the selected signals and amplifies them.

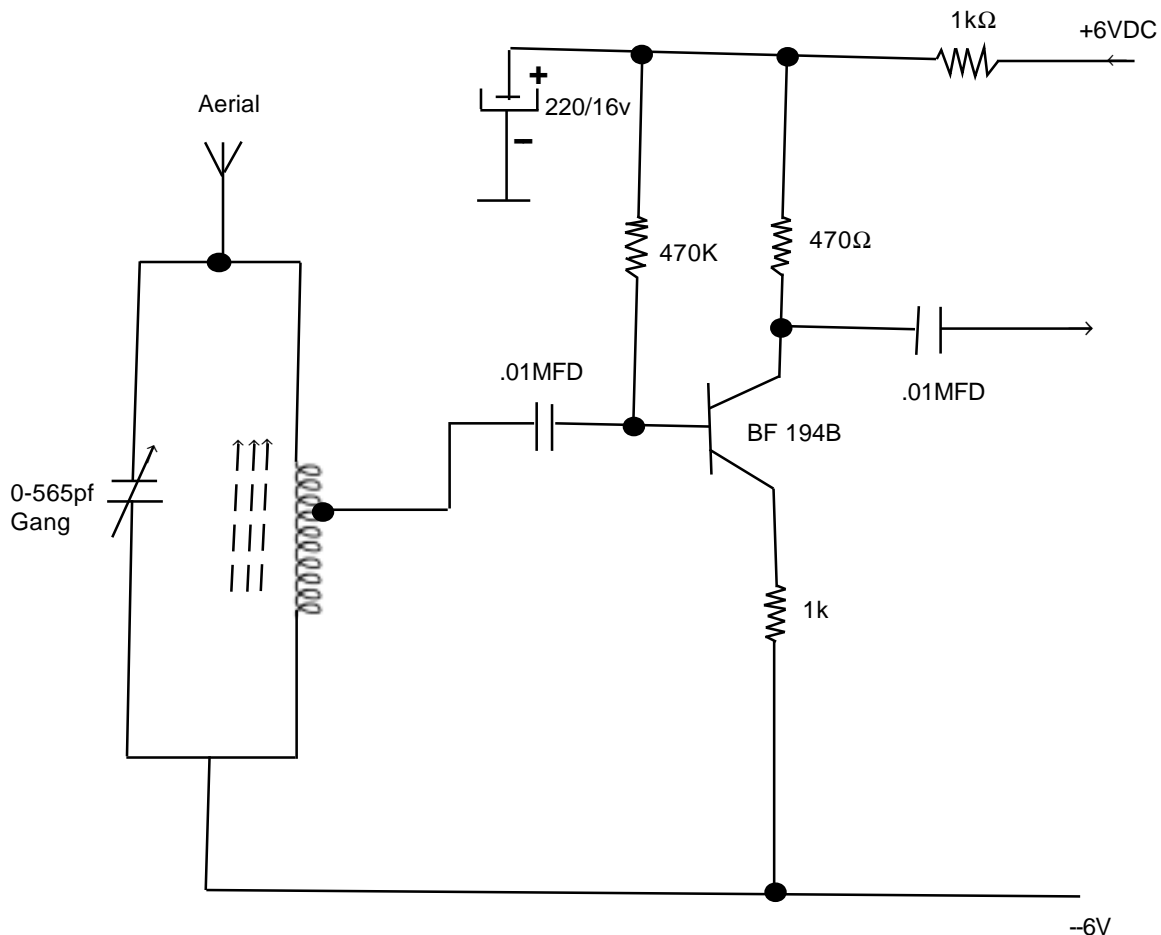

Fig. 3.5

## ADVANTAGES

1. It improves signal to noise ratio
2. It increases selectivity and sensitivity of the receiver.

## DISADVANTAGE

1. They are more unstable.

## FREQUENCY CONVERTER

It is also known as first detector. The functions of mixer and local oscillator are combined in a single stage which is called as converter. It is one of the most important stages in the superheterodyne receiver.

## FUNCTIONS

1. Local oscillator generates unmodulated R.F signal (Oscillator signal)
2. Mixer, mixes the oscillator signal with the incoming signal.
3. Converter gives IF signal in the output

## TRACKING

Local Oscillator should produce an oscillator frequency which should be equal to the sum of RF and IF ( $F_o = F_s + IF$ ). It is called tracking.

If oscillator does not track properly (Improper tracking), mismatched IF would be produced and fed to the IF amplifier. It is called as tracking error. As a result, radio stations would be received in wrong locations in the dial. To avoid this, a method which is called as three point tracking, is used.

## THREE POINT TRACKING

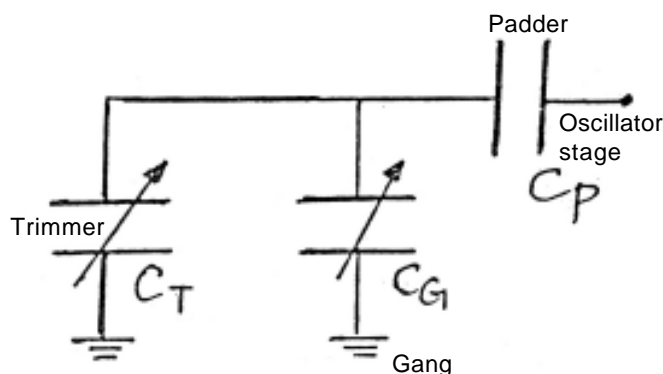

Fig. 3.6

In this method, padder capacitor is used in series and trimmer in parallel with the Ganged capacitors and they should be perfectly aligned. If it is carried out, Oscillator will properly track the RF signal in Minimum, Mid and Maximum of AM broadcast frequency range. Hence, Radio stations can be received at their correct locations in the dial.

## CONVERTER - OPERATION

In this stage, a single transistor (BF 194) is used. This stage has mixer and local oscillator. In the input section (Base) antenna coil is connected and the output section (Collector) IF transformer is connected. In emitter section oscillator coil is connected.

Local oscillator is a Hartley oscillator. This oscillator has got two sections, frequency determining and an amplifying section. The frequency determining section consists of coil (L), tuning condenser and trimmer. The amplifying section consists of transistor. The feedback network is used to sustain the oscillations.

In the input (Antenna) tuning section, antenna coil, tuning condenser and trimmer are connected. It selects desired signal and the same is fed to the base. The oscillator signal is fed to the emitter. The two signals are mixed in series. When mixing, five frequencies are produced.

In the output, intermediate frequency signal is selected. The IF transformer in collector section is a tuned transformer. It is tuned to IF signal (455 KHz).

- IF signal =  $F_o - F_s$
- $F_o$  = Oscillator Frequency
- $F_s$  = Signal Frequency

The output IF signal is applied to the IF amplifier.

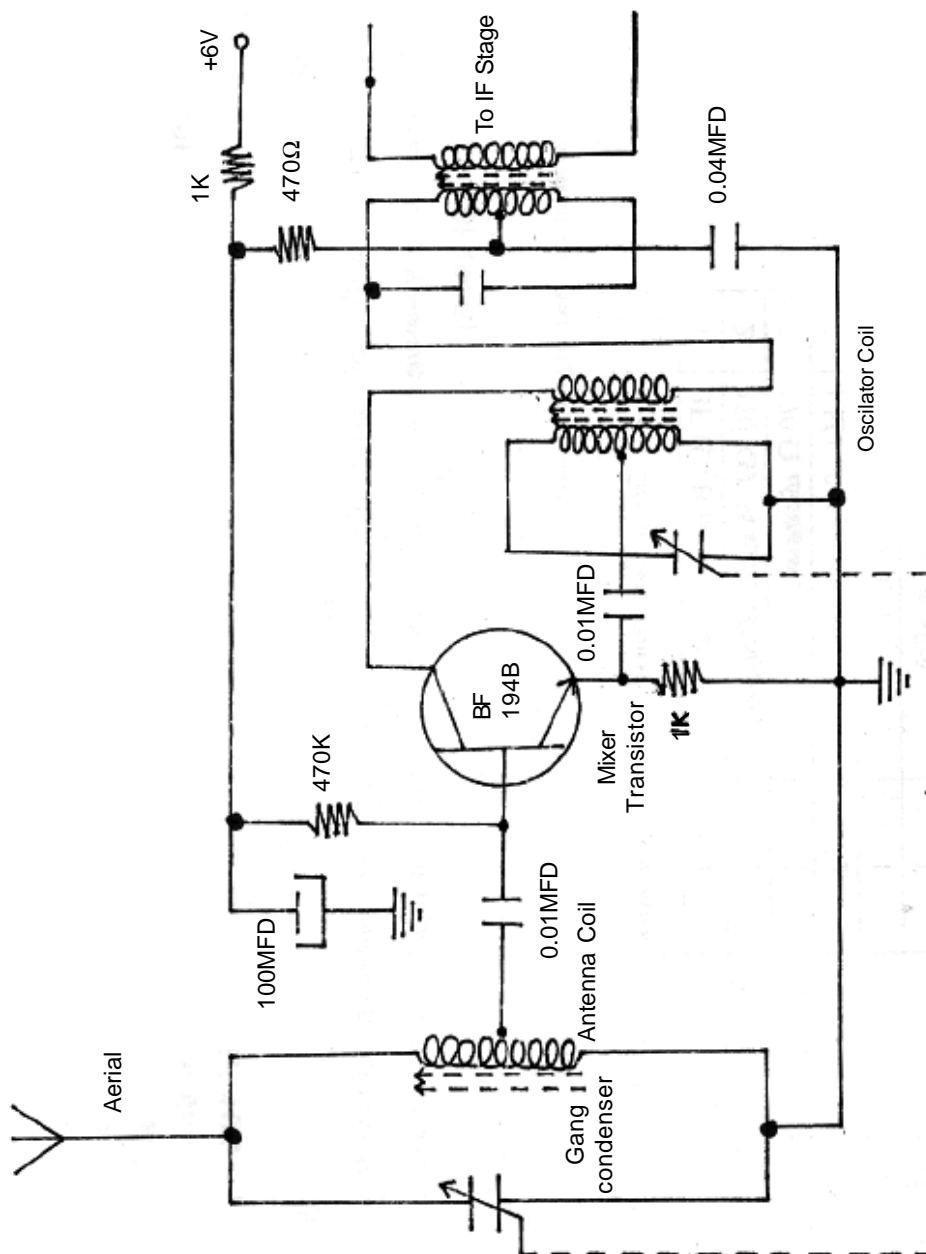

Fig. 3.7

## TWO STAGE IF AMPLIFIER

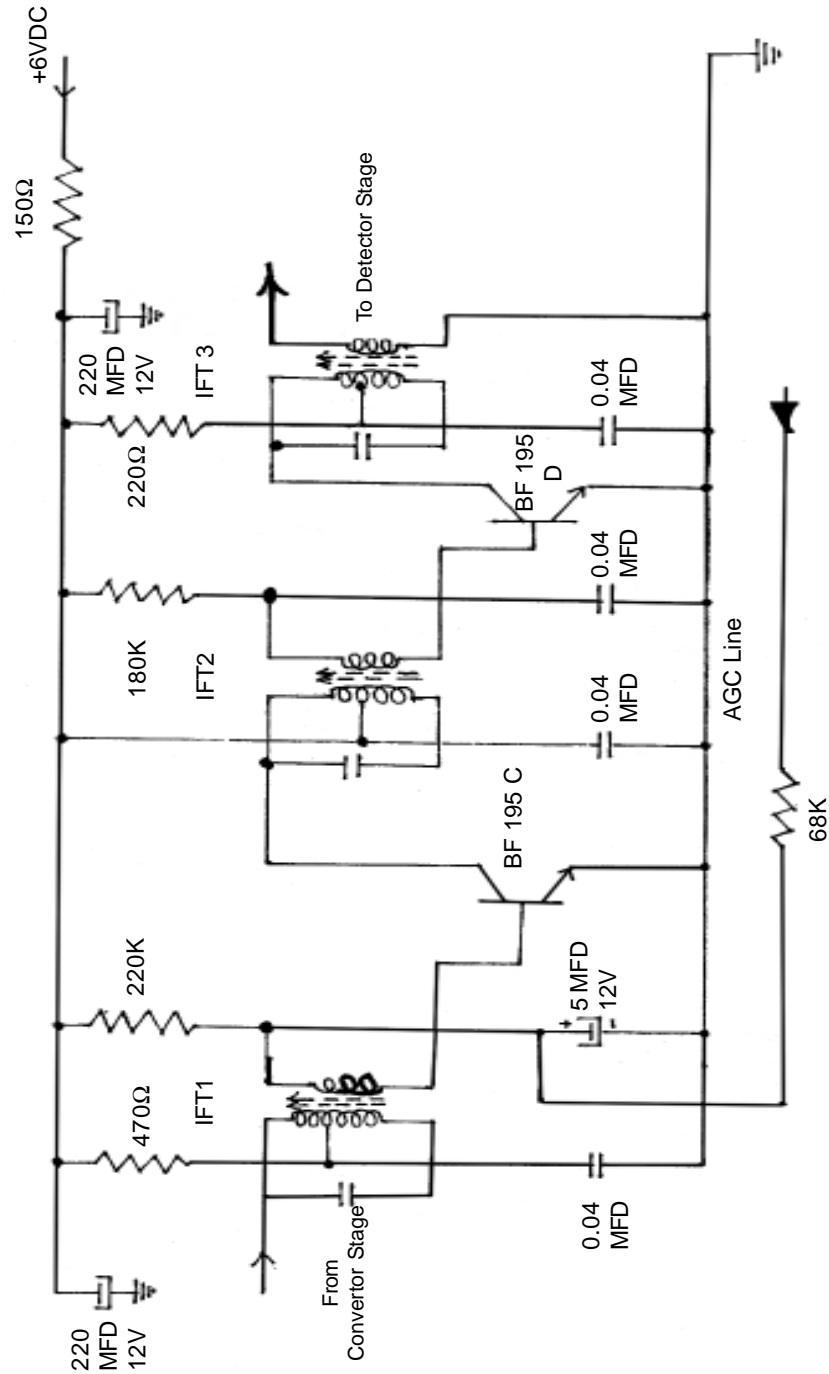

Fig.3.8

It is a tuned RF amplifier. It is designed as a transformer coupled amplifier. Two amplifier stages are used in receiver.

### FUNCTIONS

1. It amplifies the strength of IF signal
2. It improves the sensitivity of the receiver.
3. It maintains the bandwidth.

## WORKING

In this stage 2 x BF 195 transistors are used. IF transformers are connected in the input and output sections. They are tuned transformers and tuned to IF signal (455 KHz). Input signal is fed to the base of the transistor. The output signal is taken from the collector. Both two transistors amplify the strength of IF signals.

In IF transformer, the primary section acts as parallel tuned circuit. Tight coupling is applied between primary and secondary coils to maintain the band width (10 KHz). The amplified output signal is applied to the detector.

## NECESSITIES OF COMMON INTERMEDIATE FREQUENCY

If any radio station is tuned in the dial, it is designed to get common IF. if not, we have to use hundreds of IF stages for hundreds of radio stations. It is impracticable. Hence common IF is used.

## FACTORS DECIDING THE IF

The following factors are deciding the intermediate frequency.

1. The intermediate frequency should not fall in the broadcast band.
2. To avoid adjacent channel interference, low I.F should be selected.
3. To avoid image frequency interference, high IF should be selected.
4. Lower intermediate frequencies are more stable.

Considering the above factors, 455 to 460KHz is used as IF of AM radio receivers. Many AM receivers use 455 KHz as IF.

## DETECTOR

It is also known as demodulator or second detector. It is used between audio amplifier and IF amplifier. Crystal diode is used in it. These diodes as signal diodes.

## FUNCTIONS

1. It separates audio signal from IF signals.
2. RF signals are filtered.
3. Input signal is given to AVC.

## WORKING

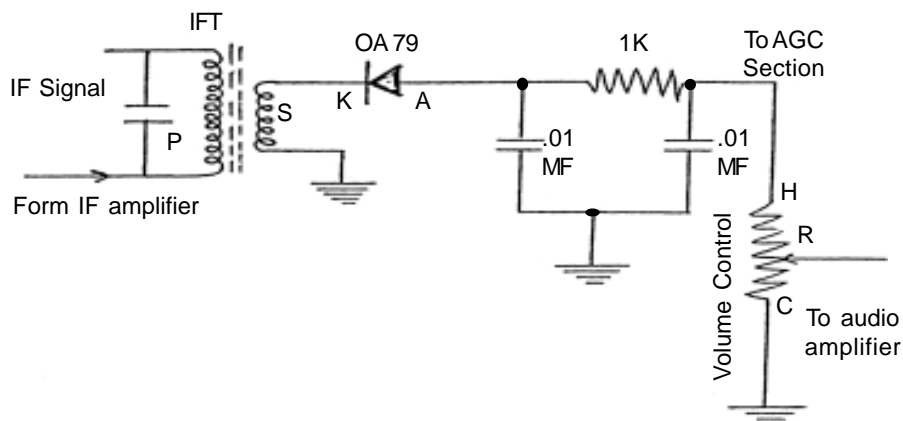

Fig.3.9

It has got three sections; Input, detector and filter. In input section IFT is used and in detector, signal diode is used. In filter section, a resistor and filter capacitors are used.

It is a diode detector. IF signal is given to the diode. Diode works as a rectifier. During negative half cycle of the input IF signal, the diode conducts. During positive half cycle, it does not. Half of IF signal is developed in the output. Then it is fed to the filter network. This filters the RF signals and the whole audio signal is separated. This audio signal voltage is developed across the load (Volume control). Finally the audio signal is applied to audio amplifier.

The output signal is also applied to AVC network.

### **AVC (AUTOMATIC VOLUME CONTROL)**

An automatic Volume control is employed in radio receiver in addition to the manual volume control. It provides stability to the output.

### **FADING**

In radio reception, variations in the signal strength are called fading. The signal received by the antenna varies continuously. Because, the signal reaches the receiving aerial from the transmitting antenna through ionosphere. Since the density of ionosphere changes continuously, the signal voltage also varies continuously. So, an unstable output sound would be produced in the receiver. An automatic volume control (AVC) is employed to eliminate the fading.

AVC circuit is classified into two types as given below.

1. Simple AVC Circuit
2. Delayed AVC Circuit

### **SIMPLE AVC CIRCUIT**

The automatic volume control which remains present in all the time is called simple A.V.C. Its principle is based upon varying the bias which is applied to RF and IF stages. The AVC bias varies according to the signal strength. The bias is more at high signal strengths and less at low signal strength.

### **WORKING**

In the detector circuit, the AVC network is included. In this network a resistor, and a bypass capacitor is used. According to the polarity of detector diode the bias is developed. Since diode is reverse biased, negative bias is developed and stored in the AVC bypass capacitor.

The AVC bias voltage is applied to the bases of RF and IF transistor. This bias depends upon the signal strength. When signal strength is normal, AGC bias voltage is also normal and as a result, the sound in the speaker is also normal.

When high signal strength is obtained, more bias (negative) is developed which reduces the gain of RF and IF stages. Conversely, when low signal strength is obtained, less bias is developed which increases the gain of RF and IF stages. It results in stable output sound from the speaker in spite of varying signal voltage.

### **DEMERITS**

1. It slightly reduces the gain of RF and IF stages
2. The audio from weak radio stations cannot be heard clearly

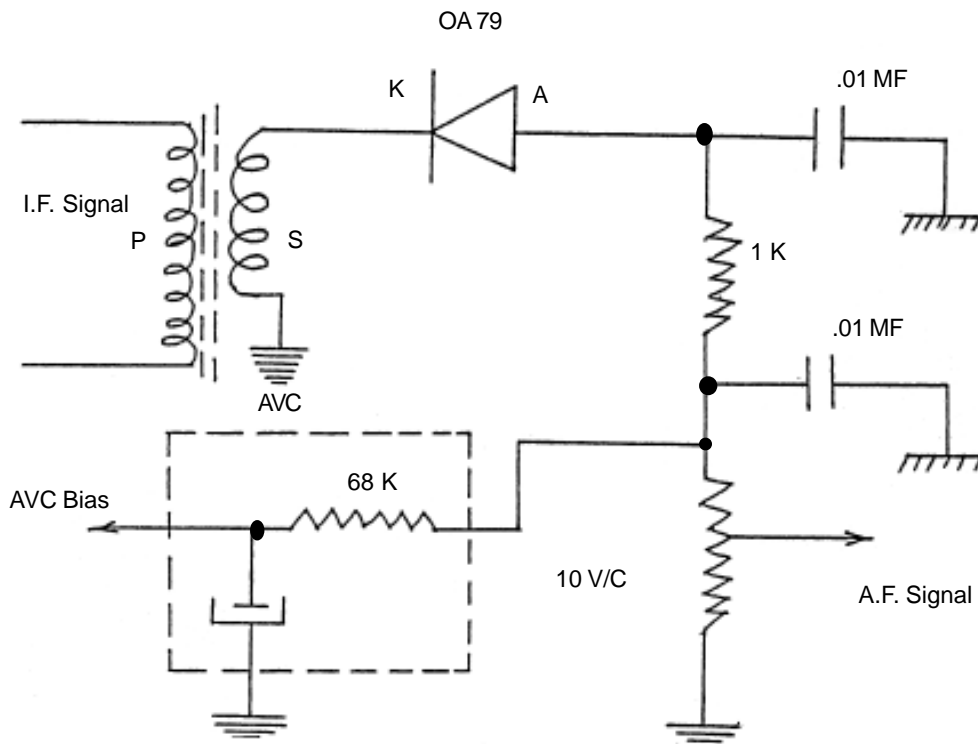

Fig.3.10

## AUDIO AMPLIFIER

The Amplifier which amplifies the frequency range of 20 Hz to 20 Kilohertz is called AF amplifier. Generally audio amplifier is divided as voltage and power amplifiers.

### FUNCTIONS

1. It amplifies the voltage and current of the audio signal.
2. It operates speaker.
3. It improves the fidelity of the receiver.

### IN THE RECEIVERS, AUDIO SECTION IS DIVIDED AS FOLLOWS:

1. Pre - amplifier
2. Driver - Amplifier
3. Output amplifier

### PRE - AMPLIFIER

It works as first voltage amplifier. Output of the detector is given to this amplifier. It amplifies the voltage of audio signal. It's output is fed to drive stage.

### DRIVER AMPLIFIER

It works as second voltage amplifier. It is employed between pre and output amplifiers. It amplifies the AF signal and feeds it to the output amplifier through driver amplifier.

### TWO STAGE VOLTAGE AMPLIFIER

It amplifies the voltage of AF signal and hence it is called as voltage amplifier.



It is a RC coupled amplifier. AF signal is obtained through volume control and  $C_1$  (0.1 mfd) and fed to the base of  $Q_1$ . The base and collector bias voltages are supplied via  $R_1$  (1 Mega ohm ) and  $R_2$  (2.2 K) respectively.  $Q_1$  amplifies the AF signal. The output is fed to the base of  $Q_2$  through  $C_2$ . The base and collector bias voltages of  $Q_2$  are supplied via  $R_3$  (220 K) and primary of driver transformer respectively.  $Q_2$  amplifies the AF signal further.  $C_4$  (0.01 mfd) acts as a high frequency filter which is also named as tone correction capacitor. The secondary of driver transformer is the input to the push pull output amplifier.  $C_1$  and  $C_2$  act as coupling capacitors

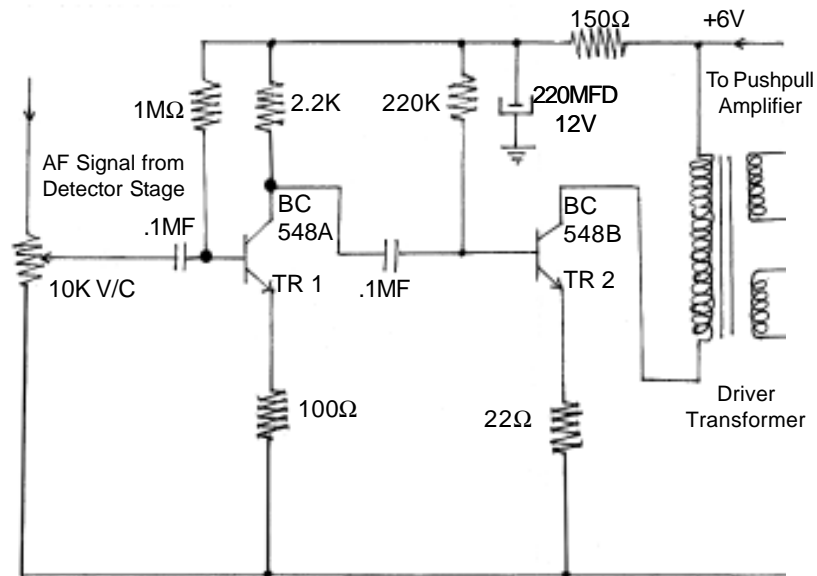

Fig.3.11

## OUTPUT AMPLIFIER

It is the final amplifier in audio section. It amplifies the power of audio signal . So it is called as power amplifier. It drives the speaker. AF output amplifier is classified into two types.

- i) Push pull amplifier using transformer
- ii) Complementary symmetry amplifier.

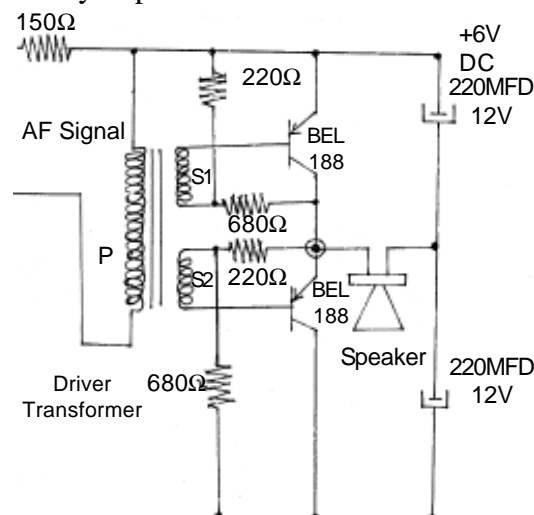

Fig.3.12

## **PUSH - PULL AMPLIFIER**

It is a single end push-pull amplifier. In this stage two identical transistors are used. Two input signals are applied to them. A driver transformer is used in its input section. In the output section of this amplifier a speaker is used. This speaker is coupled through a capacitor. It is a hum free amplifier.

### **INPUT SIGNALS**

1. Two signals are used.
2. They are having equal voltage(amplitude)
3. They are  $180^\circ$  out of phase to each other.

The driver transformer has two secondary coils which are wound in opposite directions. It delivers the required signals to the output transistors.

AF signals from the primary of the driver transformer is mutual inducted into the secondary. Two terminals A and B have AF signals which are out of phase each other. If the top terminal A be positive, while the bottom terminal B is negative. Hence  $Q_2$  forward biased and  $Q_1$  reverse biased.

$Q_2$  turns ON and amplifies the AF signal. If terminal A becomes negative, then B is positive. Hence  $Q_1$  forward biased and  $Q_2$  reverse biased  $Q_1$  turns ON and amplifies the AF signal.

Because of one transistor being pushed to ON condition and the other being *pulled* from ON condition ( that is OFF condition ) at a time, this type of amplifier is called as Push- Pull amplifier.

### **ADVANTAGES**

1. The AC output is high
2. Overall efficiency is more
3. Low power consumption
4. No noise.

### **DISADVANTAGES**

1. It is bulky and costly because it uses transformers.
2. If the two transistors are not identical, distortion occurs.
3. Distortion is more.

## **COMPLEMENTARY SYMMETRY AMPLIFIER**

It works as a direct coupled amplifier. It has no transformer, So, it is known as transformer-less audio amplifier.

In this stage, a pair of transistors (PNP and NPN) is used in order to eliminate the use of transformer. The emitters of two transistors are coupled. The input signals is given to the bases of these transistors. At the output of this amplifier, a speaker is connected through a high value capacitor.

During positive half of the input signal NPN transistor conducts. PNP transistor does not conduct. During negative half of the input signal PNP transistor conducts and NPN transistor does not conduct. In this way, both the transistors are operated as class- 'B' amplifier. In the output, total output current is added together which drives the speaker. The speaker converts the audio signal into sound.

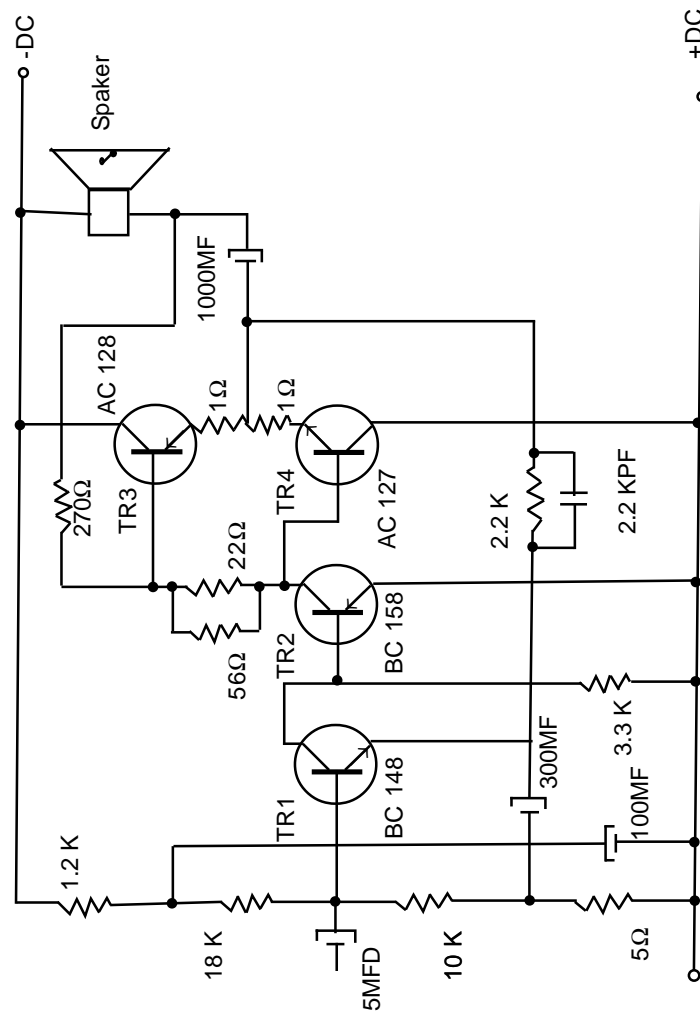

Fig.3.13

### ADVANTAGES

1. Transformers are not used. So, it is not bulky and also cheap.
2. High output power
3. Distortions eliminated
4. Low power consumption

### FM RADIO RECEIVER

It is receiver which receive the frequency modulated radio signals and reproduces the sound. It is also a superhet receiver. It consists the following stages.

1. RF amplifier
2. Mixer
3. Local oscillator
4. IF amplifier
5. Discriminator
6. Limiter

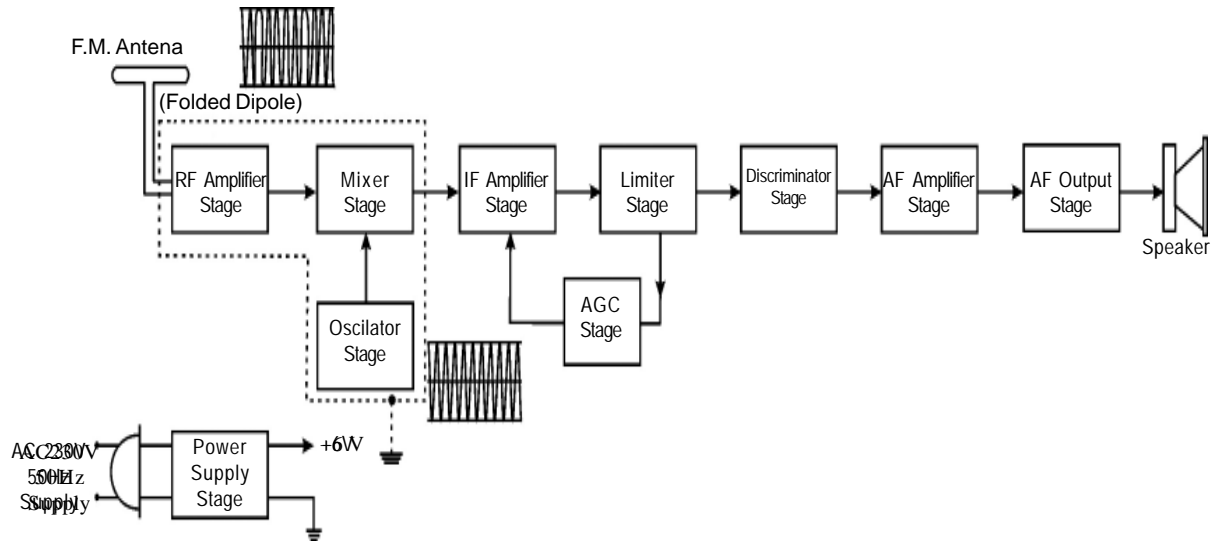

Fig. 3.14 Block diagram of FM radio receiver

### RF AMPLIFIER

It selects the desired RF signals through the aerial. It amplifies the RF signals. It improves the selectivity.

### LOCAL OSCILLATOR

It is a Hartley oscillator. It produces unmodulated radio frequency signal. These signals are fed to the mixer.

### MIXER

It has got two signals viz., RF signal and oscillator signal. It mixes them and gives IF signal as output (10.7MHz).

### IF AMPLIFIER

This is used in between discriminator and mixer. It amplifies the IF signal and also improves the sensitivity.

### DISCRIMINATOR

It is a demodulator. It separates audio signal from frequency modulated IF signal. Crystal diodes are used as detector diodes. Generally, three types of detector circuits are used as given below.

1. Travis discriminator
2. Foster- Seeley discriminator
3. Ratiodetector

### LIMITER

It controls the noise pulses which are mixed with signals. It is a final IF amplifier. It works as a clipper.

### AUDIO AMPLIFIER

First of all AF signals are de-emphasised. Then, it amplifies the audio frequency signal. It is

divided into pre amplifier, driver, and output amplifier. Pre and driver amplifiers are voltage amplifiers. Output amplifier is a power amplifier. It improves the fidelity.

**COMPARISON BETWEEN AM AND FM RECEIVERS**

<b>AM RECEIVER</b>	<b>FM RECEIVER</b>
<ol style="list-style-type: none"> <li>1. It operates with AM Signals</li> <li>2. It's frequency range is from 500 KHz to 30 MHz 88 Mhz to 108 MHz</li> <li>3. IF signal frequency is 455 KHz</li> <li>4. Bandwidth in 10 KHz</li> <li>5. It empolys detector</li> <li>6. It does not employ limiter</li> <li>7. Interference and distortion are more</li> </ol>	<ol style="list-style-type: none"> <li>1. It operates with FM Signals</li> <li>2. Its frequency range is form</li> <li>3. IF signal frequency is 10.7 MHz</li> <li>4. Bandwidth is 200 KHz</li> <li>5. It employs discriminator</li> <li>6. It employs limiter</li> <li>7. Interference and distortion are less.</li> </ol>

**DE-EMPHASIS**

At the FM receiver, an operation opposite to pre-emphasis used, is known as De-emphasis. The amplitude of high frequency signal is decreased relatively. R.C low pass filter network is used. This network is having a time constant of 75 micro seconds. It also helps to reduce the noise frequency of the signal.

**LIMITER**

The amplitude of FM signal should be constant. But while traveling from transmitter to receiver, fading, absorption and reflection of radio waves produce unwanted variation in the amplitude of signals. Hence the variations should be removed for clear reception. So limiter is used for this purpose. It is used prior to discriminator.

Is also known as 'clipper' It is similar to IF amplifier which works as a saturated amplifier. In this stage, the input FM Signal is operated between the cut off point and saturation point of amplifier. Any amplitude beyond these points does not reach the output.

**FM DETECTOR**

**INTRODUCTION**

It is known as discriminator. It is a balanced double diode demodulator. It separates audio signal from frequency modulated IF signal. The FM detector circuits are classified as follows:

**TYPES OF FM DETECTOR**

1. Travis discriminator
2. Foster-Seeley discriminator
3. Radio detector.

## TRAVIS DISCRIMINATOR

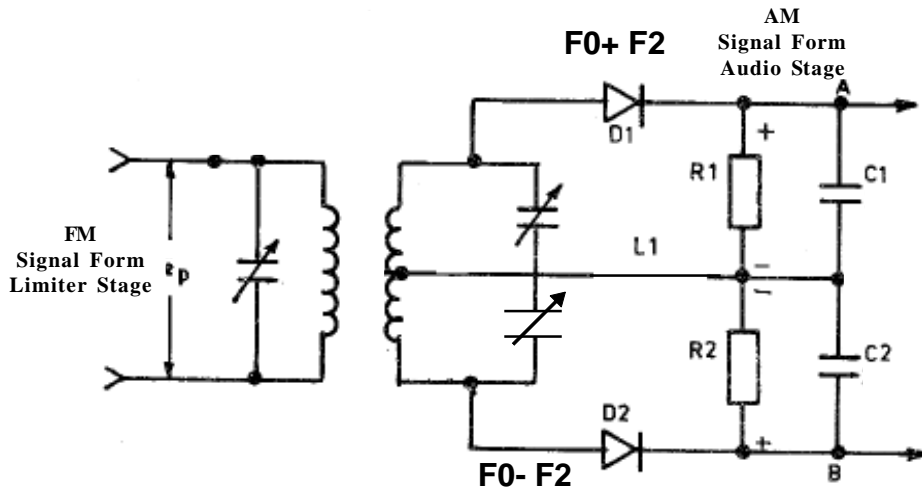

Fig. 3.15

It is a three stages tuned (or) stagger tuned discriminator. In this type, three tuned circuits are used which are tuned to three different frequencies. The first tuned circuit in the final IF transformer which is tuned to the intermediate frequency. It has two secondary coils.

Two Signal diodes are used. They are connected to the secondary coils. In the output section two filter networks are connected. These filter networks are R.C filters. Output audio signal is taken across the filter condensers.

When the input signal increases from the center frequency first diode conducts and second diode does not conduct. Hence in output, half cycle of audio signal is charged. half cycle At the output, the two half cycles are combined and taken as audio signal. The R.F signals are bypassed by the condensers. This audio signal is applied to the audio amplifier for amplification.

## FOSTER SEELEY DISCRIMINATOR

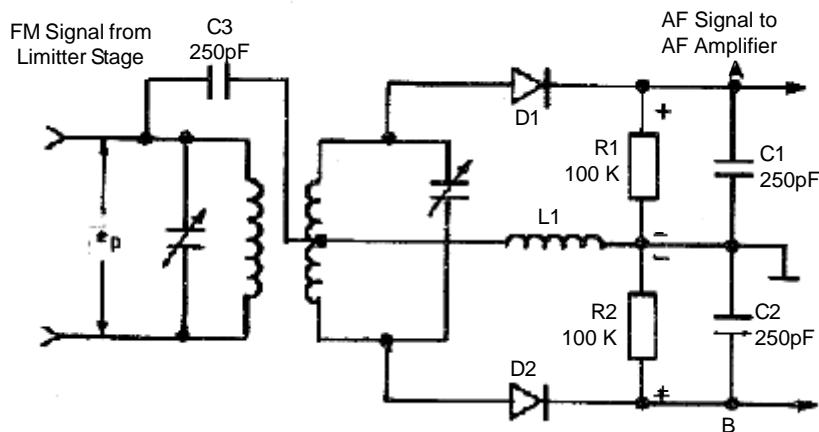

Fig. 3.16

It is also known as phase shift discriminator or center tuned discriminator. In this circuit, only two tuned circuits are used which are tuned to center frequency. Input signal is applied to it from the final IF amplifier (limiter). The final IFT has got primary and secondary coils.

Two signal diodes are employed. A coupling capacitor is connected between the primary and center tap of the secondary. So the input signal is applied to the secondary through this coupling condenser and mutual induction.

When equal signal voltage is applied, the diodes are balanced. Hence the output is the same and net audio signal output is zero. At other levels (except centre frequency) the output of one diode is greater than the other. If the total output is greater than centre frequency, the output is positive, while output is smaller, the output is negative. Carrier signals are filtered and AF signal is separated and given to the output stage.

### RATIO DETECTOR

This circuit resembles the discriminator circuit. The main difference is that the signal diodes are connected in opposite direction. It is not necessary to use a limiter stage. The final IF transformer is having two tuned circuits. The input signal is applied through coupling capacitor and output section, two filter condensers are connected and one load resistor is used.

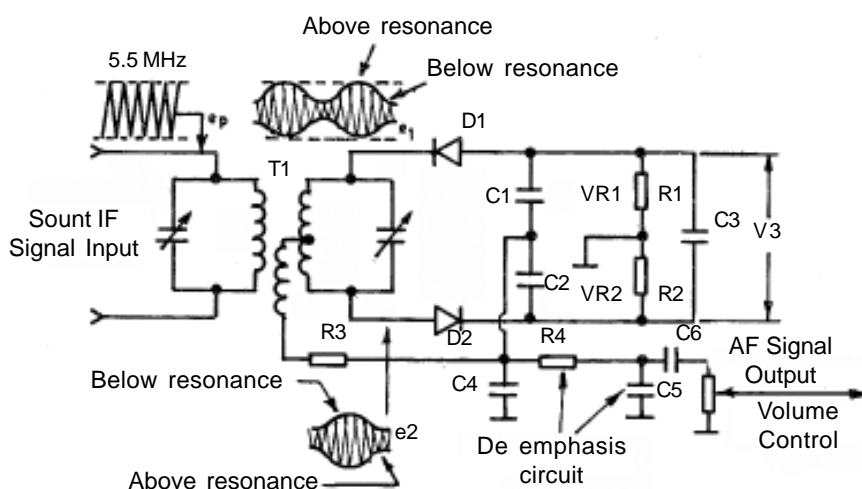

Fig. 3.17

When the unmodulated signal is applied, the output signal voltage is the same. When the input signal varies the output voltage also varies. When input signal frequency is increased, more output voltage is developed. If input signal frequency is decreased, less output voltage is developed. If input signal is increased more than centre frequency, the output of first tuned circuit is high, while the output of second tuned circuit is low. Hence the output is positive. If input signal is low, the output becomes negative.

Thus the two signal voltages are combined and thus audio signal is obtained

### DOUBLE CONVERSION

If two different IF's are used in a receiver, it is said to be Double conversion. It is used in communication receivers.

### COMMUNICATION RECEIVERS

It is a special type of superhet receiver which receives code words. For that purpose, it contains Beat Frequency Oscillator.

It is also based on the principle of superheterodyning. Two different IF stages are used in it. It is capable of receiving 2 to 16 MHz range.

First Local oscillator and RF signals are mixed in the mixer and converted into 1.7 MHz as first IF. This IF signal is amplified and fed to the second mixer stage.

The Second Oscillator is a fixed frequency oscillator. Its frequency is 1.5 MHz.

1.7 MHz and 1.5 Mhz are mixed in second mixer stage and as a result, 200 KHz is obtaine as constant second IF.

Beat Frequency Oscillator is placed next to the second IF stage to receive Morse Code. It is a LC Hartley type Oscillator.

AGC maintains the incoming signal strenght as constant. For that, AGC amplifier and AGC detector srages are used.

Detector separates the AF signal and feeds it to the Squelch circuit. Squelch circuit pervents the noise when no input signal is received. Hence, it is also said to be sound muting circuit.

AF signals are amplified by the AF amplifier and fed to the speaker. Speaker converts AF signals into sound.

### COMMUNICATION RECEIVER

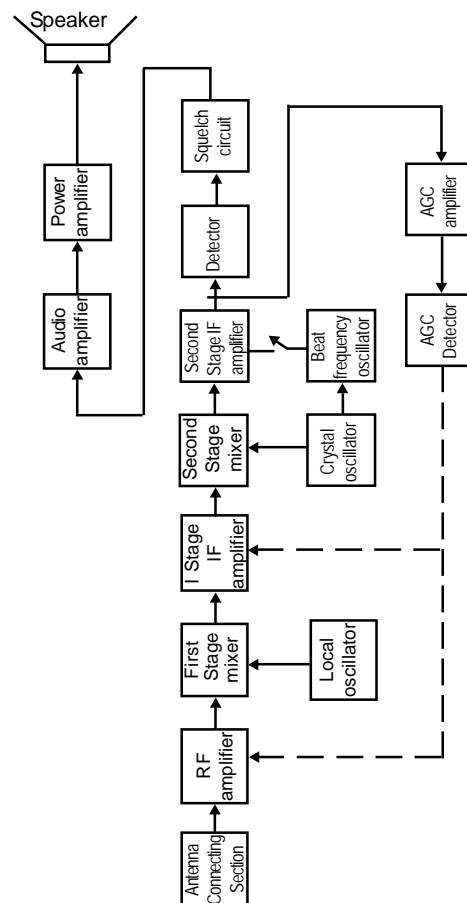

Fig. 3.18



## DIFFERENCES BETWEEN COMMUNICATION RECEIVER AND AF RECEIVER

COMMUNICATION RECEIVER	AM RECEIVER
1. Used for telecommunication only.	1. Used for entertainment and News.
2. Can be operated only by technical people only.	2. A layman can operate it.
3. Two different IF 's are used.	3. Only one IF is used.
4. Capable of receiving Morse code.	4. It cannot receive Morse code.
5. Muting circuit is used.	5. Muting circuit is not used.

### CONSTRUCTION

It consists of a stable frequency AF oscillator and RF oscillator. It contains modulator, driver and output stages. In its front panel, various controls are arranged. In this panel, a scale is fitted. This instrument can be made to operate with a.c mains or with a battery.

### 4. RADIO ALIGNMENT AND SERVICING

To align and service a radio receiver, equipments like

1. Signal generator
2. Multimeter are needed.

### SIGNAL GENERATOR

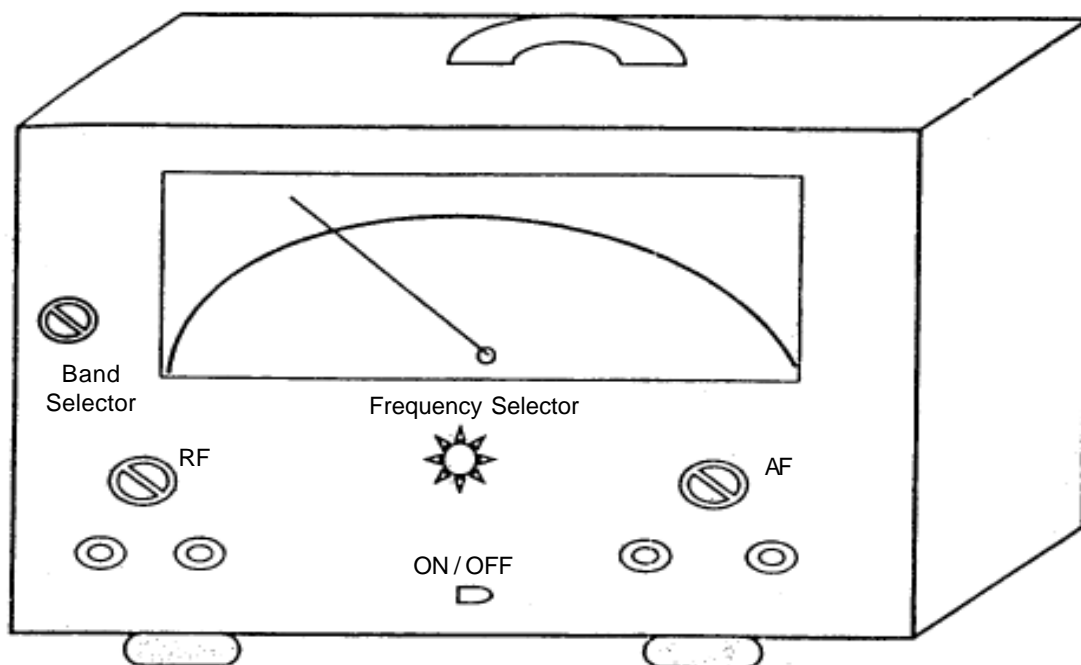

Fig. 4.1.

It is the technique to maintain a receiver in proper condition.

## **INTRODUCTION**

It is an instrument which generates audio frequency and radio frequency signals. So it is called as AF and RF signal generator. It is used to test audio stages and align the RF stage in the receiver.

## **CONSTRUCTION**

It consists of a stable frequency AF oscillator and RF oscillator. It contains modulator, driver and output stages. In its front panel, various controls are arranged. In this panel, a scale is fitted. This instrument can be made to operate with a.c mains or with a battery.

## **WORKING**

The radio frequency signal is amplified by driver and output stages Audio signals are amplified by AF amplifiers. The modulator modulates the RF and AF signals to produce modulated output signal.

## **PANEL CONTROLS**

### **1. ON / OFF SWITCH**

It is used to operate the generator.

### **2. MODE SELECTOR**

It is three positioned service control. It is operated to select the required carrier, modulated and audio signals.

### **3. BAND SELECTOR**

It is also called as range selector. It is operated to select the desired bands in the dial.

### **4. FREQUENCY SELECTOR**

It is main control. It operates to select desired signal frequencies in the dial. It is also called as tuning control.

### **5. OUTPUT GAIN CONTROLS**

They are divided into AF and RF controls. They are operated to control the gain of audio and radio frequency signals.

### **6. OUTPUT TERMINALS**

These terminals (Points) are divided into RF and AF terminals. They are used to get the output signals.

### **4.1. RADIO RECEIVER - ALIGNMENT**

It is the technique to maintain a receiver in proper condition.

## **ALIGNMENT**

The Process of adjusting tuned circuits and settings the variable capacitors to improve the selectivity and sensitivity of the receiver is called alignment. It is classified as follows:

1. IF alignment
2. RF alignment

In IF alignment intermediate frequency transformers (IFT) are tuned. In RF alignment, antenna and oscillator tuned circuits are tuned.

## REQUIREMENT

1. RF signal generator
2. Output voltmeter
3. Alignment screw drivers.
4. Multimeter
5. Working receiver

## IF ALIGNMENT

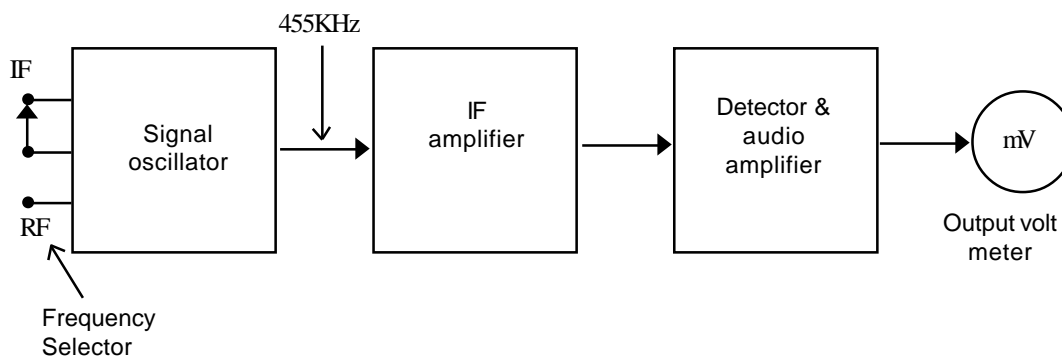

Fig. 4.2.

## SETTING THE RECEIVER

1. Disconnect the receiver's aerial.
2. Connect the output meter in the place of speaker.
3. The Oscillator section of the receiver should be disabled.
4. Connect the signal generator's terminals to the input points of IF amplifier.
5. AVC should not be functioned.
6. Volume control should be in its maximum position.
7. Tone control should be in its minimum position.

## SETTING THE GENERATOR

1. Put the generator in its ON position
2. Mode and band selector controls should be in desired positions.
3. Select the required IF signal (455KHz) by tuning the frequency selector.
4. RF output control should be in its maximum position.
5. Output terminal (Cable) is to be connected at RF output point.

## ADJUSTMENT PROCEDURE

The adjustments are to be made by alignment screw driver. First, the output IF transformer (detectot) is to be tuned, and then middle transformer and finally the input IFT should tuned. The adjustment should be finished, when maximum output is indicated in the output meter. After that, all the cores should be filled with wax.

## RF ALIGNMENT

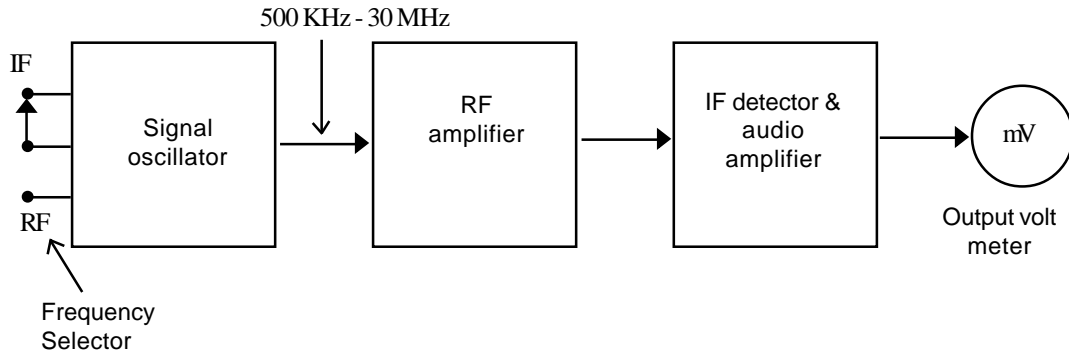

**Fig. 4.3.**

It is classified as follows:

1. Low frequency (IF) alignment
2. High frequency (HF) alignment.

## SETTING THE RECEIVER

1. Disconnect the receiver's aerial
2. Connect the output meter in the place of speaker.
3. The oscillator should be disabled.
4. Connect the generator at the aerial points.
5. AVC should not be functioned.
6. Volume control should be maximum.

## SETTING THE GENERATOR

1. Put the generator in this ON Position.
2. Mode and band selector controls are to be in desired positions.
3. Select the required RF signals by using frequency selector.
4. RF control should be in its maximum position.

## PROCEDURE

Adjust the tuned circuits for maximum output. Antenna trimmer is tuned for high frequency alignment. For low frequency alignment, the cores of coils are adjusted. The adjustment is finished when maximum output is indicated in the output meter. After finishing the adjustments, the cores and trimmers are filled with max.

## TRACKING

After aligning the receiver, it should perform equally well on the whole dial scale. To maintain this quality the intermediate frequency signal (455KHz) should be the same. The process to obtain such ability of the receiver by maintaining the constant IF signal is said to be tracking.

The tracking adjustments are done with the help of adjusting the trimmers and padders. The trimmers are adjusted for high frequency range. The padders are adjusted for low frequency range. In the middle range, adjustment is not necessary. If the two ranges of the Gang are properly tuned at any one of the bands, the receiver will function satisfactorily on all the bands.

## **FAULT FINDING TECHNIQUES**

It includes both the fault finding and its rectification. It is a sensitive job. It requires circuit diagram, proper tools, test equipment and identical components.

### **PRECAUTIONS**

- i) First of all, write down the name, model of the receiver and number of bands and stages in the receiver and number of transistors and integrated circuits are used.
- ii) The receiver should not be opened unless main cords are checked.
- iii) After opening the receiver the missed and burnt components (parts) should be observed.
- iv) Before connecting the receiver to the supply, high voltage short test should be carried out.
- v) After giving the supply to the receiver, observe for any spark, smoke or burning smell.
- vi) While checking or finding a fault, the tuned circuits of the receiver should not be tuned.

### **PROCEDURE**

For perfect and quick servicing, a step by step procedure should be followed. The following tests are to be followed.

- i) Static Test
- ii) Dynamic Test

### **STATIC TEST**

It is also known as primary test. It is the test which is checked before giving the supply to the receiver. It is classified as follows.

- i) Main cord Test
- ii) HT short Test
- iii) Speaker click Test
- iv) Visual Test

### **MAINS CORD TEST**

Every equipment has mains cord. Checking this cord is called as mains cord test.

### **HT SHORT TEST**

It is the test to check the short circuit between the high voltage supply lines.

### **SPEAKER CLICK TEST**

In the receiver, the test which is used to check the speaker is known as speaker click test.

### **VISUAL TEST**

Observation of missing parts and burnt components in the receiver is called as visual test.

### **DYNAMIC TEST**

It is also known as secondary test. It is the test, which is checked after giving supply to the receiver. It is classified as follows:

- i) Signal Test

- ii) Voltage Test
- iii) Current Test
- iv) Resistance Test
- v) Programme Test

## **SINGEL TEST**

It is also called as signal injection. It is the test which is used to check the stages by giving external signals. Signal injectors are used for this purpose. Fault stages can be identified by this test.

## **VOLTAGE TEST**

After identifying the defective stages, this voltage test is used. So, this test is used to identify the components. To achieve this test, voltages are to be measured. Voltmeter is used for this test.

## **CURRENT TEST**

It is the test which is used to find out the components by measuring current through them, It is the one of the most important tests. Ammeter is used for this.

## **RESISTANCE TEST**

It is the test which is used to confirm the fault components by measuring its resistance. Ohmmeter is used for it.

## **PROGRAMME TEST**

It is the final test. It is the test to check the programmes in different station.

## **SOAK TEST**

After servicing a receiver we should test it by putting in 'on' condition for long hours to confirm whether it is ok or not. This type of testing is called as Soak test.

## **VIBRATION TEST**

After servicing an intermittently working receiver, we should vibrate it slightly to confirm whether it is ok or not. This method of testing is called as Vibration test.

## **4.2 RADIO RECEIVER-SERVICING**

The probable causes for the defects in radio receivers and trouble shooting procedure.

The defects can commonly be classified into two types

- 1) Live fault
- 2) Dead fault

### **LIVE FAULT**

If a radio receiving radio stations in 'on' condition, it is termed as 'Live fault'.

### **DEAD FAULT**

No sound is heard even after a radio receiver is in 'on' condition, it is said to be 'Dead Fault'.

#### **1) DEAD FAULT**

- i) Clean the battery contacts and check the battery.
- ii) If battery eliminator is used, check its output dc voltage. If output voltage is obtained

- iii) Check power cord, on-off switch, power transformer diodes, and capacitor. Also solder the output leads properly. If the receiver is still dead even after the output of battery eliminator is obtained.
- iv) Check the speaker and speaker coupling capacitor.
- v) Check the output transistors and their biasing resistors.
- vi) Check the driver transformer, voltage amplifier transistor and their biasing resistors.
- vii) I.F transistors, decoupling capacitors and mixer transistor may get short circuited.
- viii) Dry soldering may be occurred.
- ix) Copper print may be opened.

## **2) 'HUM' IN RECEIVER**

- i) If pulsating dc is supplied (instead of pure dc) to a receiver, a 'hum' sound is heard.
- ii) Defective filter capacitors
- iii) Also check power transformer and diodes

## **3) B+SHORT**

- i) Shorted output Transistors
- ii) Shorted driver transformers and voltage amplifier transistors.
- iii) Shorted filter Capacitors, IF Transistors, Mixer Transistor and decoupling Capacitors.

## **4) LOW VOLUME**

- i) Low output voltage from eliminator
- ii) Leaky output Transistors (AC128 x 2)
- iii) Defective speaker and speaker coupling capacitor
- iv) IFTs may be mis aligned; broken cores
- v) Defective volume control
- vi) Defective OA 79 detector diode

## **5) ONLY HISS SOUND IS HEARD IN THE RECEIVER; NO RECEPTION OF RADIO STATIONS (NO SIGNAL)**

- i) Defective oscillator coil
- ii) Check mixer transistor BF 194B and its biasing voltage
- iii) Defective Ganged capacitor
- iv) Shorted trimmer
- v) Band switch open
- vi) Dry soldering; copper print open

## **6) ONLY FEW RADIO STATIONS IS RECEIVED**

- i) Mis aligned antenna coil
- ii) Check mixer transistor
- iii) Defective Gang
- iv) IFTs should not be aligned properly
- v) Dry soldering; Copper print cut

## **7) NOISY RECEPTION**

- i) Misaligned antenna coil
- ii) IFTs misaligned
- iii) Chassis earth is improper
- iv) Trimmer should be aligned correctly
- v) Loose connection in AC power card.

## **8) RECEPTION WITH WHISTLING SOUND**

- i) Defective oscillator coil
- ii) Defective Gang, Trimmer
- iii) First IFT and Oscillator coil should be aligned properly

## **9) DISTORTED AUDIO**

- i) Check the output Transistors, Speaker and its coupling capacitor.
- ii) Misaligned IFTs
- iii) Mismatching of audio o/p transistors

## **10) INTERMITTENT RECEPTION**

Dry soldering (or) copper print cut. First rectify it and then the PCB should be undergone vibration test. If the defect still persists

- i) Defective speaker
- ii) Defective volume control, on-off switch
- iii) Improper position of batteries
- iv) Improper connections of eliminator

After rectifying this fault, the receiver should be Soak tested.

## **11) MOTOR BOATING SOUND FROM RECEIVER**

If a 'dub', 'dub' sound is heard from radio receiver, this type of defect is called as motor boating.

- i) Check the B<sup>+</sup> capacitor and decoupling capacitors

## **12) A RECEIVER IS WORKING IN LOW FREQUENCY AND BUT NOT IN HIGH FREQUENCY END**

Defective Gang.

## **13) NOISE PRODUCED WHILE TUNNING**

Defective Gang.

## **14) NOISE HEARD WHILE VOLUME CONTROL IS VARIED**

Defective volume control. It should be cleaned with kerosene.

## **15) RADIO STATIONS RECEIVED IN WRONG LOCATIONS IS THE DIAL**

Improper alignment of oscillator coil and its trimmer.

## **16) FULL VOLUME; VOLUME CANNOT BE REDUCED**

- i) Defective volume control or its earth may be disconnected.



## QUESTIONS

### I. CHOOSE THE BEST ANSWERS

1. The first transmitter was made by \_\_\_\_\_ in the year 1887  
A) Marconi                      B) Major Armstrong      B) J.L Baird      D) Enrich Hertz
2. Microphone is a transducer It Converts \_\_\_\_\_ in to audio signals.  
A) Light                      B) Sound                      C) Air                      D) Walter
3. The simplest radio receiver is the  
A) Crystal                      B) Am                      C) FM                      D) Communication
4. The first Radio station was established in July 1927 at \_\_\_\_\_  
A) Chennai                      B) Delhi                      C) Bombay      D) Bangalore
5. The speaker audio signal in to Converts \_\_\_\_\_  
A) Sound                      B) Light                      C) RF waves      D) Oscillator Waves
6. The Bandwidth of AM Radio Receiver is \_\_\_\_\_  
A) 5KH2                      B) 20KH2                      C) 10KH2                      D) 100KH2
7. The Amplifier which Amplifies the frequency range of 20HH2 to 20KH2 is called \_\_\_\_\_  
A) RF Amplifier      B) Oscillator                      C) AF Amplifier      D) Convertor
8. In Fm Receiver the frequency range is from \_\_\_\_\_  
A) 88MH2                      B) 100MH2 - 150MH2  
C) 500KCS to 30MH2      D) 1.5MH2 – 30MH2
9. In Fm Receiver IF signal output is \_\_\_\_\_  
A) 10MH2                      B) 30MH2                      C) 107MH2                      D) 5MH2
10. No sound is heard ever after a radio Receiver I sin on condition It is said to be \_\_\_\_\_  
A) Live Fault                      B) intermittat Fault      C) Dead Fault                      D) Low sound Fault

### II. ANSWER IN ONE OR TWO WORDS

1. Define Buffer Amplifier.
2. What is image frequency?
3. What is AF Amplifier?
4. What is Pre Amplifier?
5. State two reasons for hum in Receiver.

### III. ANSWER IN FEW LINES

1. What are the principles followed in radio Receivers generally?
2. Define Amplitude modulation Radio receiver.
3. What are the functions of RF Amplifier?
4. What are the functions of Fm detectors?
5. Define the function of Limiter in Fm Receiver.

### IV. EXPLAIN ABOUT ONE PAGE

1. Describe the Various abilities of a radio receiver.
2. Draw and Explain the block diagram of TRF receiver.
3. Draw and Explain the RF amplifier circuit.

4. Draw and Explain the Detector circuit used in Am Receivers.
5. What are the reasons for dead Fault in a radio Receiver.

#### **V.ANSWER BRIEFLY**

1. Draw and Explain the Block diagram of Am Radio Transmitter.
2. Draw and Explain the Block diagram of Fm Radio Transmitter.
3. Draw and Explain the Block diagram of Am Radio Receiver.
4. Draw and Explain the two If amplifier circuit.
5. Draw and Explain the push-pull amplifier.
6. Draw the block diagram of communication receiver and Explain.

#### **ANSWERS**

1.D 2.B 3.A 4.C 5.A 6.C 7.C 8.A 9.C 10.C

## 4. TV TRANSMISSION AND RECEPTION

### 4.1 INTRODUCTION - TV TRANSMISSION PRINCIPLE

Television means “To see from a Distance”. The first demonstration of actual television was given by J.L.Baird in UK and C.F.Jenkins in USA around 1927. However a complete shape of television was developed by V.K.Zworykin.and.Bansworth. We could understand that prior to the development of Television the camera tube would have been developed, since any image shown in the TV should be captured through the camera first. Ofcourse the camera tube was also developed by Zworykin. Initially TV was developed through vacuum tubes then by semiconductor devices like transistors and ICs. In this fast developing world the Television is playing important role in Communication.

#### TELEVISION COMPRISES THE FOLLOWING THREE ACTIVITIES:

- i) Capturing Pictures—Camera
- ii) Recording and Transmission
- iii) Reception or Reproduction

You are going to study about the above aspects stage wise in the following chapters.

### 5.1 SCANNING

Scanning can be compared to our eyes. While reading a book, the eye starts to read from left end and move towards right end. On finishing the right end automatically the eye will come to the next line i.e left end of the next line and starts to read towards right end and this will continue. As like this, the same activity should be happened in camera tube and television picture tube.

When this is happened in the camera tube the image falls on the camera tube is divided into many parts and these separated parts are once again framed as a picture in the television picture tube. This is achieved through the process called scanning.

The electron ray from the electron gun moved from left to right and right to left and top to bottom and bottom to top of the television screen and camera tube is known as Scanning.

To form a picture on the television screen we need 15625 scanning lines per second. Since the scanning speed is very high it can not be -visible to our eyes. Because the eyes persistent time is  $1/16^{\text{th}}$  of a second.

Thus if the scanning rate per second is made greater than sixteen, the eye is able to integrate the changing levels of brightness in the scene. The motion picture on the television is easily compared with the screening of cinema.. In cinema projection 24 picture frames should be crossed in front of the camera in one second. If there is any change in this the action may not be real.

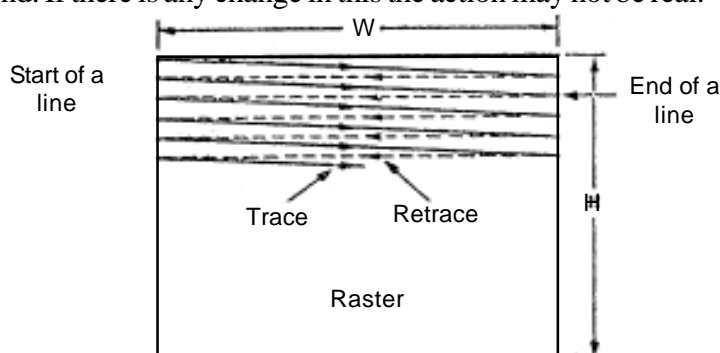

Fig. 4.1.

Just like the same in television 15625 scanning lines” divided into 25 picture frames. As per that one frame consists  $(15625/25) = 625$  scanning lines. Hence as we seen earlier for a complete action picture we need  $(25 \times 625) = 15625$  scanning are needed. The electron ray moving from left to right and right to left is called as Horizontal scanning and the ray moving from top to bottom and bottom to top is called Vertical scanning.

During scanning there are two important points worth noting.

- i) The electron ray which moves from left to right alone visible to our eyes, since it alone carries signal. This line is termed as Trace line.
- ii) When the ray is moved from right to left it don't have any signal in it and it is blanked by applying blanking pulses. This line termed as Retrace line.

## SEQUENTIAL SCANNING OR PROGRESSIVE SCANNING

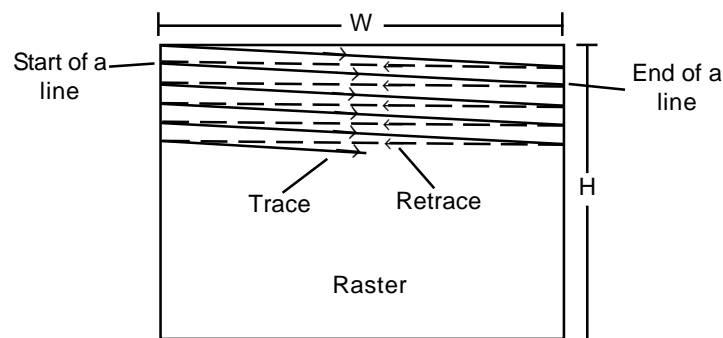

**Fig. 4.2.**

The electron ray starts to scan from line one and follow continuously (trace line and retrace line) making full scanning of 15625 in one second is called as progressive scanning. In this method there was an unavoidable problem occurred.

## FLICKER EFFECT

Although the rate of 24 pictures per second in motion pictures and that of scanning 25 frames per second in television pictures is enough to cause an illusion of continuity, they are not rapid enough to allow the brightness of one picture or frame to blend smoothly into the next through the time when the screen is blanked between successive frames. This results in a definite flicker of light that is very annoying to the observer when the screen is made alternately bright and dark.

This problem is solved in motion pictures by showing each picture twice, so that 48 views of the scene are shown per second although there are still the same 24 frames per second. As a result of the increased blanking rate, flicker is eliminated.

## INTERLACED SCANNING

In television pictures are effective rate of 50 vertical scenes per second is utilized to reduce flicker. This is accomplished by increasing the downward rate of travel of the scanning electron beam, so that every alternate line gets scanned instead of every successive line. Then, when the beam reaches the bottom of the picture frame, it quickly returns to the top to scan those line that were missed in the previous scanning. Thus the total number of lines are divided into two groups called 'Fields' V Each field is scanned alternatively. This method of scanning is known as interlace scanning and is illustrated in the figs.- It reduces flicker to an acceptable level since the area of the screen is covered at twice the

rate. This is like reading alternate lines of a page from top to bottom once and then going back to read the remaining lines down to the bottom.

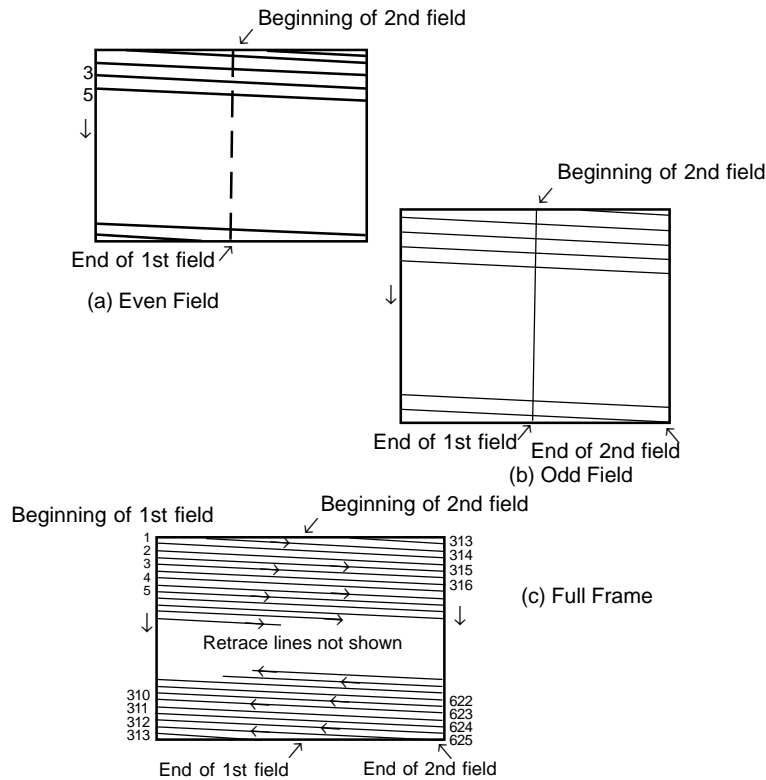

**Fig. 4.3.**

In the 625 line monochrome system, for successful interlaced scanning, the 625 lines of each frame or picture are divided into sets of 312.5 lines and each set is scanned alternately to cover the entire picture area. To achieve this the horizontal sweep oscillator is made to work at a frequency of 15625 Hz ( $312.5/25 = 625$  lines), but the vertical sweep circuit is run at a frequency of 50 instead of 25 Hz. Note that since the beam is now deflected from top to bottom in half the time and the horizontal oscillator is still operating at 15625 Hz, only half the total lines, i.e.  $312.5(625/2=312.5)$  get scanned during each vertical sweep. Since the first field ends in a half line and the second field commences at middle of the line on the top of the target plate or screen (see fig), the beam is able to scan the remaining 312.5 alternate lines during its downward journey. In all then, the beam scans 625 lines ( $312.5 \times 2 = 625$ ) per frame at the same rate of 15625 lines ( $312.5 \times 50 = 15625$ ) per second. Therefore, with interlaced scanning the flicker effect is eliminated without increasing the speed of scanning, which in turn does not need any increase in the channel bandwidth.

## THE PICTURE TUBE MONOCHROME PICTURE TUBE

Modern monochrome picture tubes employ electrostatic focusing and electromagnetic deflection. A typical black and white picture tube is shown in fig. The deflection coils are mounted externally in a specially designed yoke that is fixed close to the neck of the tube. The coils when fed simultaneously with vertical and horizontal scanning currents deflect the beam at a fast rate to produce the raster. The composite video signal that is injected either at the grid or cathode of the tube, modulates the electron beam to produce brightness variations on the screen. This results in re-construction of the picture on the

raster, bit by bit, as a function of time. However, the information thus obtained on the screen is perceived by the eye as a complete and continuous scene because of the rapid rate of scanning.

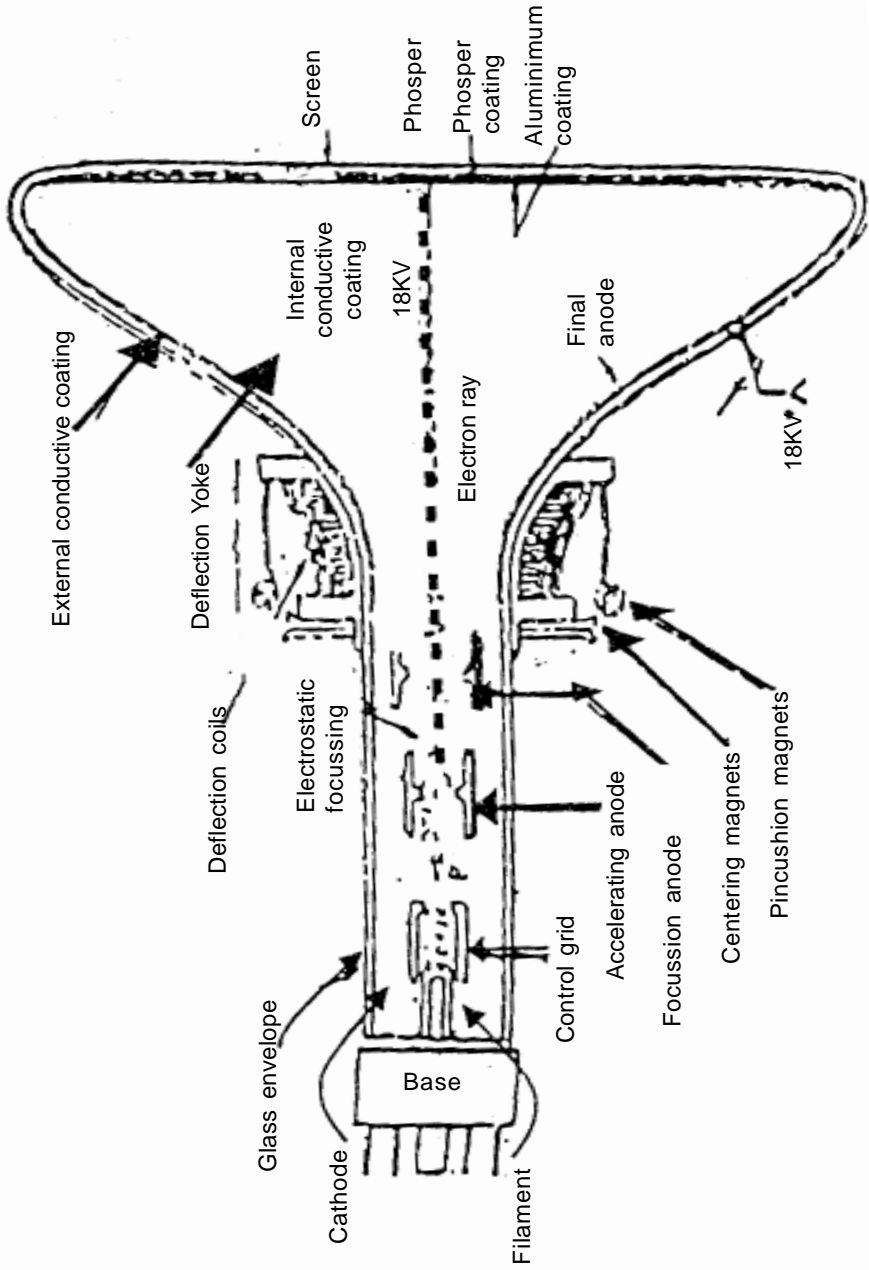

**Fig. 4.4.**

The various electrodes that constitute the electron gun are shown in fig. The cathode is indirectly heated and consists of a cylinder of nickel that is coated at its end with throted tungsten or barium and strontium oxides. These emitting materials have low work-function and when heated permit release of sufficient electrons to form the necessary stream of electrons within the tube. The control grid (Grid no. 1) is maintained at a negative potential with respect to cathode and con oils the flow of electrons from the cathode. However, instead of wire mesh structure, as in a conventional amplifier

tube, it is a cylinder with a small circular opening to confine the electron stream to a small area. The grids that follow the control grid are the accelerating or screen grid (Grid No.2) and the focusing grid (Grid No.3). These are maintained at different positive potentials with respect to the cathode that vary between +200 V to +600V. All the elements of the electron gun are connected to the base pins and receive their rated voltages and from the tube socket that is wired to the various sections of the receiver.

The focus anode is larger in diameter and is operated at a higher potential than the first anode. The resulting field configuration between the two anodes is such that the electrons leaving the crossover point at various angles are subjected to both convergent and divergent forces as they move along the axis of the tube. This in turn alters the path of the electrons in such a way that they meet at another point on the axis. The electrode voltages are so chosen or the electric field is so varied that the second point where all the electrons get focused is the screen of the picture tube. Electrostatic focusing is preferred over magnetic focusing because it is not affected very much by changes in the line voltage and needs no ion-spot correction.

In order to give the electron stream sufficient velocity to reach the screen material with proper energy to cause it to fluoresce, a second anode is included within the tube. This is a conductive coating with colloidal graphite on the inside of the wide bell of the tube. This coating, called aquadag, usually extends from almost half-way into the narrow neck to within 3 cm of the fluorescent screen as shown in fig. It is connected through a specially provided pin at the top or side of the glass bell to a very high potential of over 15 KV. The exact voltage depends on the tube size and is about 18 KV for a 48 an monochrome tube. The electrons that get accelerated under the influence of the high voltage anode area, attain very high velocities before they hit the screen. Most of these electrons go straight and are not collected by the positive coating because its circular structure provides a symmetrical accelerating field around all sides of the beam.

Because of very high velocities of the electrons which hit the screen, secondary emission takes place. If these secondary emitted electrons are not collected, a negative space charge gets formed near the screen which prevents the primary beam from arriving at the screen. The conductive coating being at a very high positive potential collects the secondary emitted electrons and thus serves the dual purpose of increasing the beam velocity and removing unwanted secondary electrons. The path of the electron current flow is thus from cathode to screen, to the conductive coating through the Secondary emitted electrons and back to the cathode through the high voltage supply.

## **DEFLECTION YOKE**

The physical placement of the two pairs of coils around the neck of the picture tube is illustrated in fig and the orientation of the magnetic fields produced by them is shown in fig. In combination, the vertical and horizontal deflection coils are called the 'Yoke'. This yoke is fixed outside and close to the neck of the tube just before it begins to flare out (see fig.).

The magnetic field of the coils reacts with the electron beam to cause its deflection. The horizontal deflection coil which sweeps the beam across the face of the tube from left to right is split into two sections and mounted above and below the beam axis. The vertical deflection coil is also split into and placed left and right on the neck in order to pull the beam gradually downward as the horizontal coils sweep the beam across the tube face. Each coil gets its respective sweep, input, from the associated sweep circuits, and together they form the raster upon which the picture information is traced. It may be noted that a perpendicular displacement results because the magnetic field due to each coil reacts

with the magnetic field of the electron beam to produce a force that deflects the electrons at right angles to both the beam axis and the deflection field.

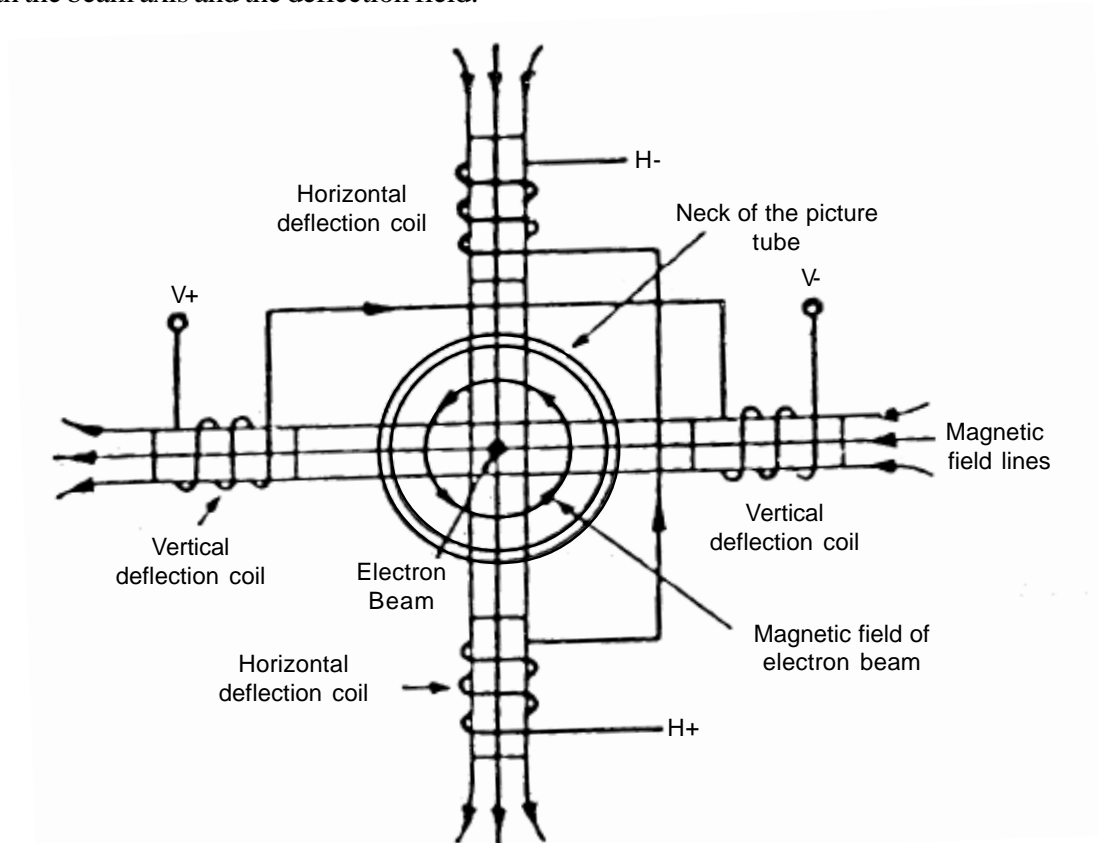

**Fig.4.5.**

## **ASPECT RATIO**

Normally the picture tubes are manufactured as per the following ratio. It is the ratio between length and height of the picture tube. The ratio is 4:3.

## **KELL FACTOR**

During scanning in a raster all 625 horizontal lines are not completely used. Among those 40 lines per frame (20 lines per field) are utilized for vertical blanking. Hence  $625 - 40 = 585$  lines are termed as Active lines. Among these 70% lines are alone called as Effective lines and this is termed as Kell factor.

## **4.2 CAMERA TUBE**

A Television camera tube may be called the eye of a Television system. There are four types of camera tubes.

1. Iconoscope
2. Image Orthicon
3. Vidicon
4. Plumbicon

The first developed storage type of camera tube was 'Iconoscope' which has now been replaced by image-orthicon of its high light sensitivity, stability and high quality picture capabilities. The light



sensitivity is the ratio of the signal output to the incident illumination. Next to be developed was the vidicon and is much simpler in operation. Similar to the vidicon is another tube known as plumbicon.

## **CHARACTERISTICS OF CAMERA TUBES**

### **LIGHT TRANSFER CHARACTERISTICS**

It is nothing but, the output current of the camera tube is depends upon the light falls on the glass face plate.

### **SPECTRAL RESPONSE**

The camera tube could able to sense the light variation that our eyes could able sense.

### **SENSITIVITY**

It is the capacity of converting video signal of very small image. The camera tube should have this to a required level.

### **DARK CURRENT**

The output signal received when no light falls on the glass face plate is called Dark current.

### **LAG CHARACTERISTICS**

When the camera tube could not able to sense the high speed light variation, it is known as Lag characteristics.

### **RESOLVING POWER**

Sensing the White and Black portions of the picture and giving the output accordingly is known as Resolving power.

## **IMAGE ORTHICON CAMERA TUBE**

This tube makes use or the high photo emissive sensitivity obtainable from photo cathodes, images multiplication at the target caused by secondary emission and an electron multiplier. A sectional view of an image orthicon is shown in the fig. It has three main sections: They are

- i) Image Section
- ii) Scanning Section
- iii) Multiplier Section

### **I) IMAGE SECTION**

The inside of the glass face plate at the front is coated with a silver-antimony coating sensitized with cesium, to serve as photocathode. Light from the scene to be televised is focused on the photocathode surface by a lens system and the optical image thus formed results in the release of electrons from each point on the photocathode in proportion to the incident light intensity. Photo cathode surface is semitransparent and the light rays penetrate it to reach its inner surface from where electron emission takes place. Since the number of electrons emitted at any point in the photocathode has a distribution corresponding to the brightness of the optical image, an electron image of the scene of picture gets formed on the target side of the photo coating and extends towards it. Though the conversion efficiency of the photocathode is quite high, it cannot store charge being a conductor.

For this reason the electron image produced at the photocathode is made to move towards the target plate located at a short distance from it. The target plate is made of a very thin sheet of glass and

can store the charge received by it. This is maintained at about 400 volts more positive with respect to the photocathode, and the resultant electric field gives the desired acceleration and motion to the emitted electrons towards it.

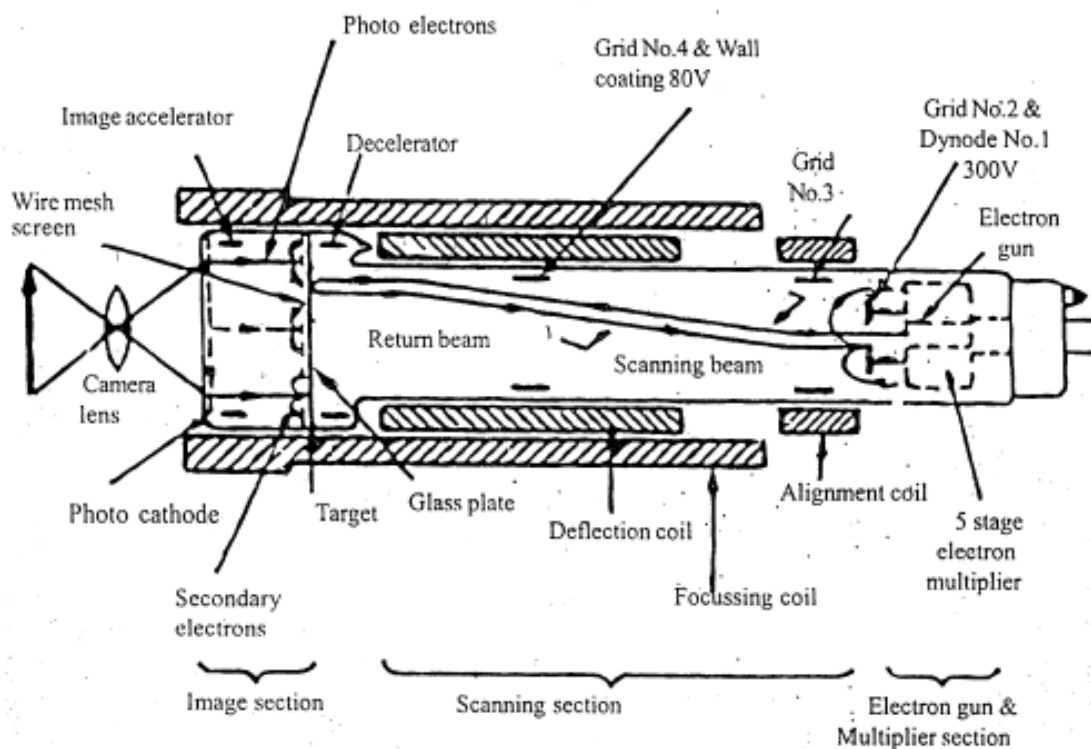

**Fig.4.6**

For storage action this charge on the target plate should not spread laterally over its surface, during the storage time, since this would destroy the resolution of the device. To achieve this the target is made out extremely thin sheet of glass. The positive charge distribution builds up during the frame storage time (40 ms) and thus enhances the sensitivity of the tube. It should be clearly understood, that the light from the scene being televised continuously falls on the photocathode, and the resultant emitted electrons on reaching the target plate cause continuous secondary emission. This continuous release of electrons results in the building up of positive charge on the target plate.

Because of the high secondary emission ratio, the intensity of the positive charge distribution is four to five times more as compared to the charge liberated by the photocathode. This increase in charge density relative to the charge liberated at the photocathode is known as 'image application' and contributes to the increased sensitivity of image orthicon. As shown in fig the two sided target has the charge image on one side while an electron beam scans the opposite side. Thus, while the target plate must have high resistivity laterally for storage action, it must have low resistivity along its thickness, to enable the positive charge to conduct to the other side which is scanned. It is for this reason that the target plate is very thin, with thickness close to 0.004 mm. Thus, whatever charge distribution builds up on the one side of the target plate due to the focused image appears on the other side, which is scanned and it is from here that the video signal is obtained.

## II) SCANNING SECTION

The electron gun structure produces a beam of electrons that is accelerated towards the target.

As indicated in the figure, Positive accelerating potentials of 80 to 330 volts are applied to grid 2, grid 3, and grid 4, which is connected internally to the metalized conductive coating on the inside wall of the tube. The electron beam is focused at the target by magnetic field of the external focus coil and by voltage supplied to grid 4. The alignment coil provides magnetic field that can be varied to adjust the scanning beams position if necessary, for correct location. Deflection of electron beam's to scan the entire target plate is accomplished by magnetic fields of vertical and horizontal deflecting coils mounted on yoke external to the tube. These coils are fed from two oscillators, one working at 15625Hz, for horizontal deflection and the other operating at 50 Hz for vertical deflection.

The target plate is close to zero potential and therefore electrons in the scanning beam can be made to stop their forward motion at its surface and then return towards the gun structure. The grid 4 voltage is adjusted to produce uniform deceleration of electrons for the entire target area. As a result, electrons in the scanning beam are slowed down near the target. This eliminates any possibility of secondary emission from this side of the target plate. If a certain element area on the target plate reaches a potential of, say 2 volts during the storage time, then as a result of its thinness the scanning beam sees the charge deposited on it, part of which gets diffused to the scanned side and deposits an equal number of negative charges on the opposite side. Thus out of the total electrons in the beam, some get deposited on the target plate, while the remaining stop at its surface and turn back to go towards the first electrode of the electron multiplier. Because of low resistivity across the two sides of the target, the deposited negative charge neutralizes the existing positive charge in less than a frame time. The target can again become charged as result of the incident picture information to be scanned during the successive frames. As the target is scanned element by element, if there are no positive charges at certain points, all the electrons in the beam return towards the electron gun and none gets deposited on the target plate. The number of electrons, leaving cathode of the gun, is practically constant, which travel backward provide signal current that varies in amplitude in accordance with the picture information. Obviously then, the signal current is maximum for black areas on the picture, because absence of light from black areas on the picture does not result in any emission on the photocathode, and there is no secondary emission at the corresponding points on the target and no electrons are needed from the beam to neutralize them. On the contrary for high light areas, on the picture, there is maximum loss of electrons from the target plate, due to secondary emission, and these results in large deposits of electrons from the beam and this reduces the amplitude of the returning beam current. The resultant beam current that turns away from the target, is thus maximum for black areas and I minimum for bright areas on the picture. High intensity light causes large charge imbalance on the glass target plate. The scanning beam is not able to completely neutralize it in one scan. Therefore earlier impression persists for several scans.

## **ELECTRON MULTIPLIER SECTION**

The returning stream of electrons arrive at the gun close to the aperture from which electron beam emerged. The aperture is a part of a metal disc covering the gun electrode. When the returning electrons strike the disc which is at a positive potential of about 300 volts, with respect to the target, they produce secondary emission. The disc serves as first stage of the electron multiplier. Successive stages of the electron multiplier are arranged symmetrically around and back of the first stage. Therefore secondary electrons are attracted to the dynodes' at progressively higher positive potentials. Five stages of multiplication are used, details of which are shown in fig. Each multiplier stage provides a gain of approximately 4 and thus a total gain  $4^5$  1000 is obtained at the electron multiplier. This is known as

signal multiplication. The multiplication so obtained maintains a high signal to noise ratio. The secondary electrons are finally collected by the anode, which is connected to the highest supply voltage of +1500 volts in series with a load resistance  $R_L$ . The anode current through  $R_L$  has the same variations that are present in the return beam from the target and amplified by the electron multiplier. Therefore voltage across  $R_L$  is the desired video signal; the amplitude of which varies in accordance with light intensity variations of the scene being televised. The output across  $R_L$  is capacitive coupled to the camera signal amplifier. With  $R_L = 20 \text{ KOhms}$  and typical dark and high light currents of magnitudes 30 A and 5 A respectively, the camera output signal will have an amplitude of 500 mV peak-to-peak.

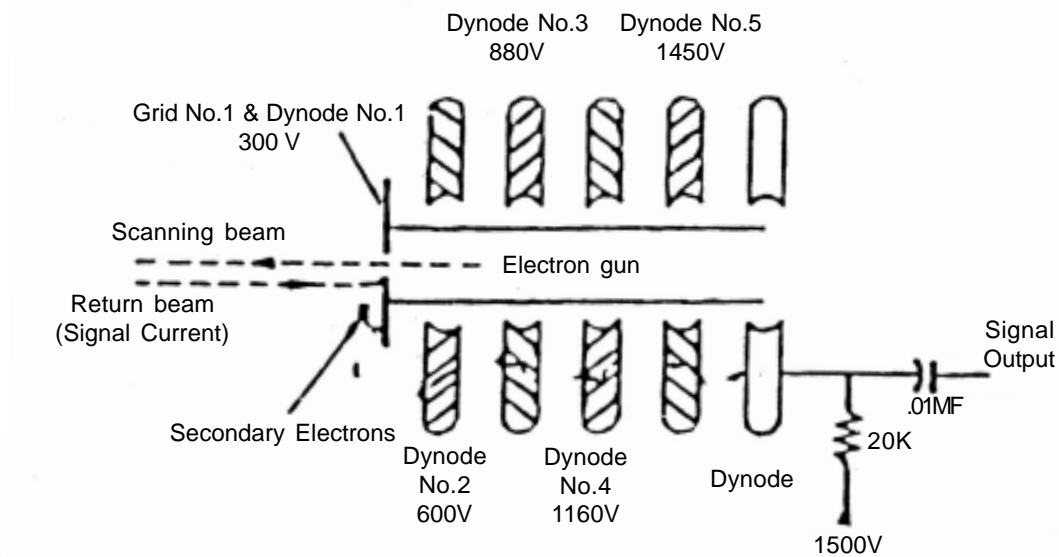

Fig. 4.7.

## VIDICON

The Vidicon came into general use in the early 50's and gained immediate popularity because of its small size and ease of operation. It functions on the principle of photoconductivity, where the resistance

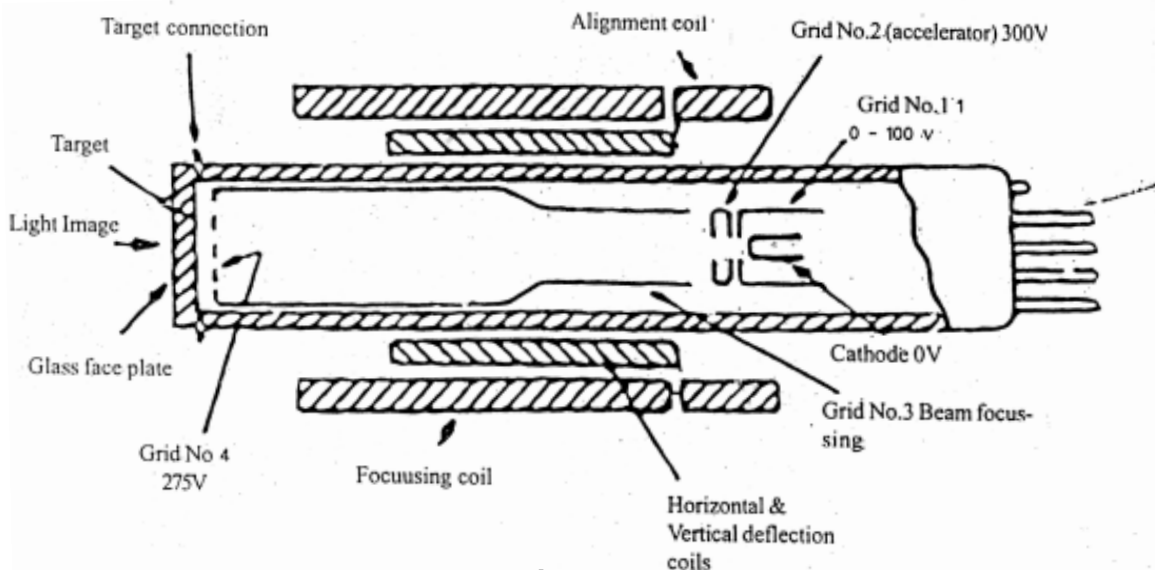
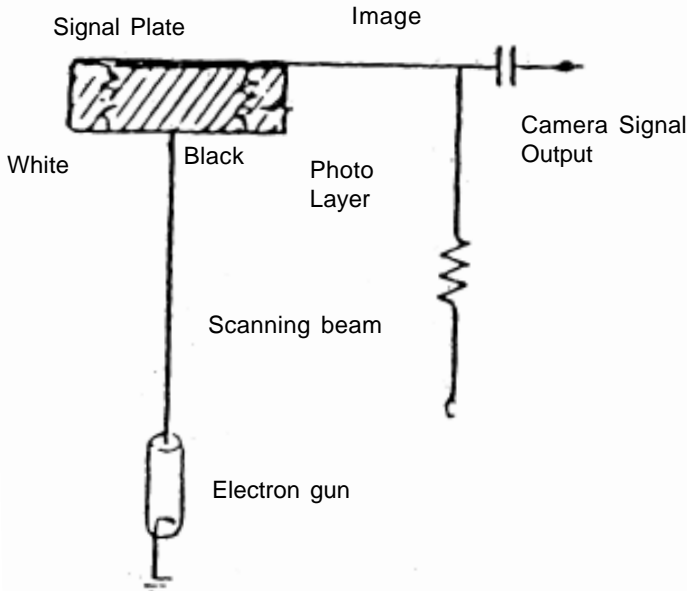

Fig. 4.8.

of the target material shows a marked decrease when exposed to light. Fig illustrates the structural configuration of a typical vidicon, and the second fig shows the circuit arrangement for developing camera signal output. As shown there, the target consists of a thin photo conductive layer of either selenium or antimony compounds. This is deposited on a transparent conducting film, coated on the inner surface of the face plate. This conductive coating is known as signal electrode or plate. This conductive coating is known as signal electrode or plate. Image side of the photo layer, which is in contact with the signal electrode, connected to DC supply through the load resistance  $R_L$ . The beam that emerges from the electron gun is focused on surface of the photoconductive layer by combined action of uniform magnetic field of an external coil and electrostatic field of grid No3. Grid No4 provides a uniform decelerating field between itself, and the photo. conductive layer ,so that the electron beam approaches the layer with allow velocity to. prevent any secondary emission. Deflection of the beam, for scanning the target, is obtained by vertical and horizontal deflecting coils - placed around the tube.

**SIGNAL CURRENT**

As the beam scans the target plate, it encounters different positive potentials on the side of the photo layer that faces the gun. Sufficient number of electrons from the beam are then deposited on the photo layer surface to reduce the potential of each element towards



**Fig. 4.9**

the Zero cathode potential. The remaining electrons, not deposited on the target, return back and are not utilized in the vidicon. However, the sudden change in potential on each element, while the beam scans, causes a current flow in the signal electrode circuit producing a varying voltage across the load resistance  $R_L$ . Obviously, the amplitude of current and % consequent output voltage across  $R_L$  are directly proportional to the light intensity variations on the scene. Note that, since, a large current would cause a higher voltage drop across  $R_L$ , the output voltage most negative for white areas. The video output voltage, that thus develops across the load resistance (50 K-ohms) is adequate and does not need any image or signal multiplication as in an image orthicon. The output signal is further amplified by conventional amplifiers, before it leaves the camera unit. This makes the vidicon a much simpler' picture tube.

## PLUMBICON

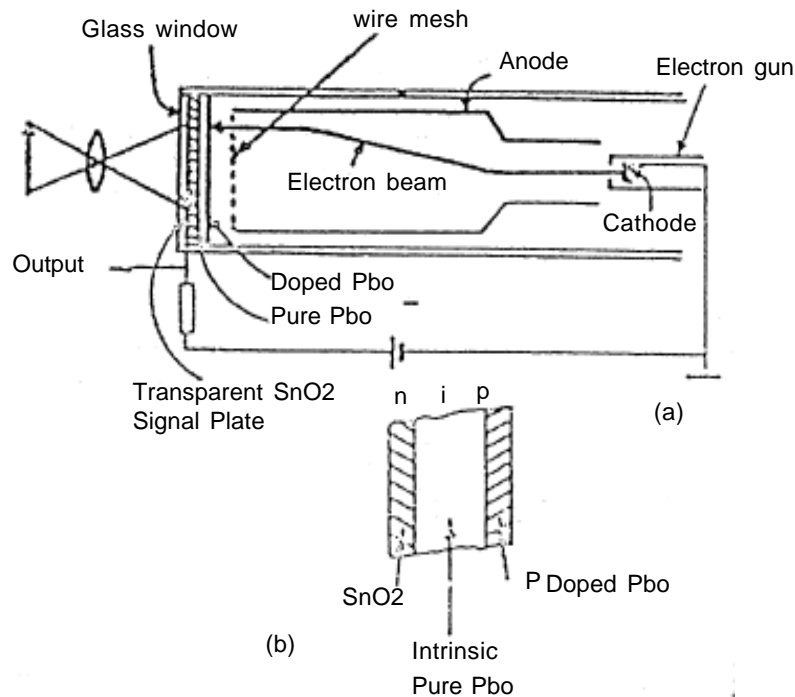

**Fig. 4.10.**

This picture tube has overcome many of the less favorable features standard vidicon. It has fast response and produces high quality pictures low light levels. Its smaller size and light weight, together with low-power operating characteristics, makes it an ideal tube for transistorized television cameras.

Except for the target, plumb icon is very similar to the standard vidicon. Focus and deflection are both obtained magnetically. Its target operates effectively as a P-I-N semiconductor diode. The inner surface of the faceplate is coated a thin transparent conductive layer in tin oxide ( $\text{SnO}_2$ ). This forms a strong N type ( $N_+$ ) layer and serves as the signal plate of the target: On the scanning side of this layer is deposited a photoconductive layer of pure lead monoxide ( $\text{PbO}$ ) which is intrinsic or T type. Finally the pure  $\text{PbO}$  is doped to form a P type semiconductor on which the scanning beam lands. The details of the target are shown in the fig. The overall-thickness of the target is  $15 \times 10^{-6}$  m. The fig(b) shows necessary circuit details for developing the video signal. The photoconductive target of the plumb icon similar to the photoconductive target in the vidicon, except for the method of discharging each storage element. In the standard vidicon, each element acts as the leaky capacitor, with the leakage resistance decreasing with increasing light intensity. In the plumb icon, however, each element serves as a capacitor in series with a reverse biased light controlled diode. In the signal circuit, the conductive film of tin oxide ( $\text{SnO}_2$ ), is connected to the target supply of 40 volts through an external load resistance  $R_L$  to develop the camera output signal voltage. Light from the scene being televised is focused through the transparent layer of tin-oxide on to the photoconductive lead monoxide. Without light the target prevents any conduction because of absence of any charge carriers and so there is little or no output current. A typical value of dark current is around  $4 \text{ nA}$  ( $4 \times 10^{-9}$  Amp). The incidence of light on the target results in photo excitation of semiconductor junction between the pure  $\text{PbO}$  and doped layer. The resultant decrease in resistance causes signal current flow which is proportional to the incident light on each photo element. The overall thickness of the target is 10 to .20  $\mu\text{m}$ .

## CAMERA TUBES COMPARISON

S.No	Characteristics	ImageOrthicon	Vidicon	Plumbicon
1.	Light Transfer	Emission Based	Photo Conductive	Photo Conductive
2.	Sensitivity	Very High	High	High
3.	S/N ratio	80 db	50 db	50 db
4.	Speed	No Halo lag	High halo lag	Low Halo lag
5.	Spectral response	Equivalent to eye	Good	Less in Red
6.	Operation	Bit tough	Easy	Easy
7.	Cost	High	Low	Bit High
8.	Size	Big	Small	Medium

## TV CAMERA & COMPOSITE VIDEO SIGNAL

Any program that is produced in the studio must be captured 'by the camera and converted as signal. In this stage deflection and synchronizing pulses are also produced. The deflection pulses are sent to the camera and the synchronizing, pulses are sent to the camera amplifier.

In camera amplifier, the signals from camera tube and sync pulses are attached. It is amplified and fixed, to certain level. This is composite video signal.

## VIDEO AMPLIFIER AND MONITOR

The composite video signal produced is amplified to the required level. The quality of the signal is monitored through the monitor placed here.

## DISTRIBUTOR & SWITCHER

The-signal from other transmission studios are received here and amplified. The quality of the signals are monitored by a monitored place here.

## MODULATION AND TRANSMISSION SECTION

In TV transmission video waves are to be amplitude modulated and sound waves are to be frequency modulated. Hence the respective carrier waves are generated through crystal oscillators are fed to the modulators. Thus the modulations are carried over and sent to the transmitter for transmission.

## COMPOSITE VIDEO SIGNAL

It consists of the following:

1. Video Signal
2. Horizontal Blanking pulses
3. Vertical Blanking pulses
4. Horizontal Synchronizing pulses
5. Vertical Synchronizing pulses

Composite video signal consists of camera signal corresponding to the desired picture information, blanking pulses to make the retrace invisible, and synchronizing pulses to synchronize the transmitter and receiver scanning. A horizontal synchronizing (sync) pulse is needed at the end of each active line period whereas a vertical sync pulse is required after each field is scanned. The amplitude of both horizontal and vertical pulse is kept the same to obtain higher efficiency of picture signal transmission

but their duration (width) is chosen to be different for separating them at the receiver. Since sync pulses are needed consecutively and not simultaneously with the picture signal, these are sent on a time division basis and thus form a part of the composite video signal.

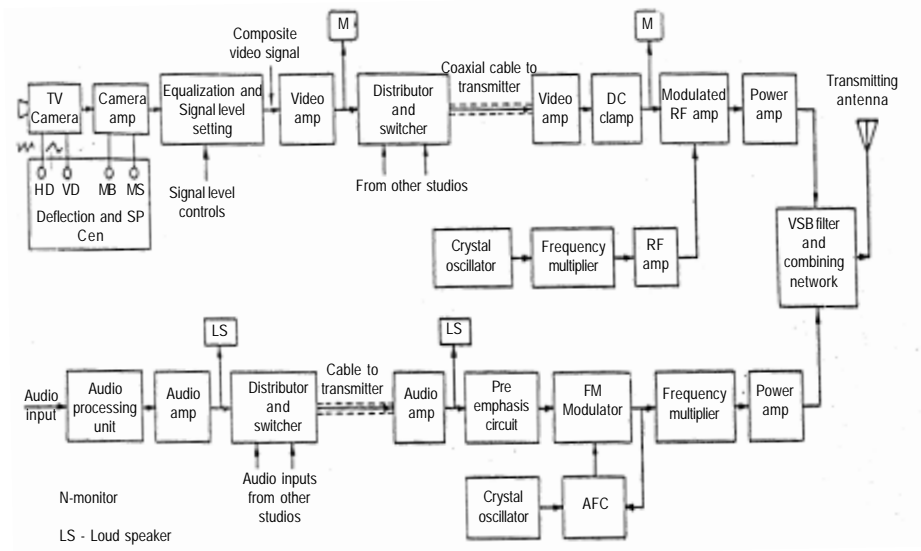

**Fig. 4.11.**

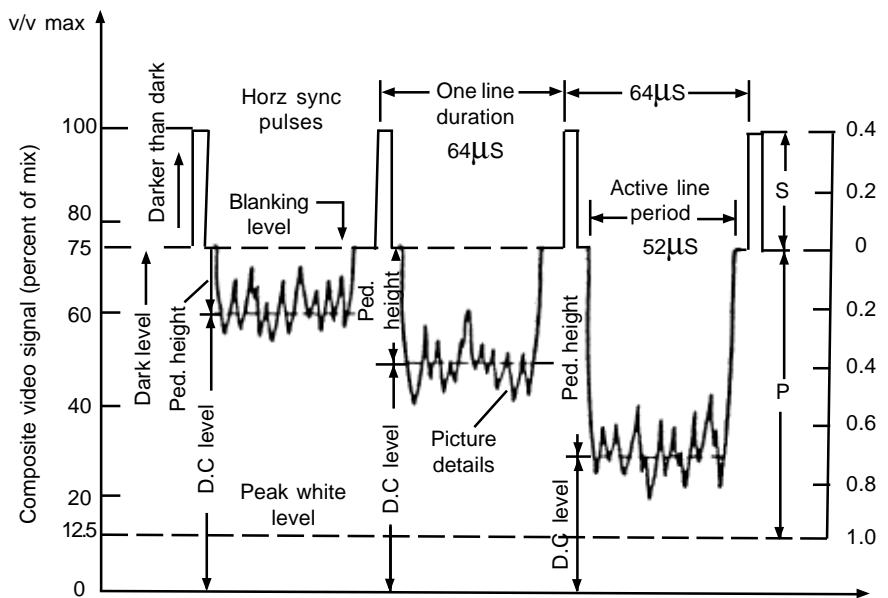

**Fig. 4.12. Composite Video Signal**

### **HORIZONTAL SYNC & BLANKING PULSE DETAIL**

The line period for one complete Horizontal line is  $64\mu$  sec. In that trace line period is  $52\mu$  sec: Retrace time period is  $12\mu$  sec.

### **VERTICAL SYNC AND BLANKING PULSE DETAIL**

The time period of one field is  $20m$  sec. In this, vertical trace is  $18.72m$  sec and  $1.28m$  sec is for retrace.

### **SERRATED SYNC PULSES**



In order to avoid the interruption to the field sync due to line sync, the vertical sync pulses are divided into 5 half-lines having time period of  $4.7\mu$  sec. This is called as Serrated Sync pulses. To perform this under Interlaced scanning method, in odd fields to start half-line 312.5 ' and in even field the line.625 (half-lines), these pulses are made to five half-lines ( $27.3\mu$  sec).

**EQUALIZING PULSES**

The vertical oscillator trigger potential level marked as trigger level. It intersects the two filter outputs profiles at different points. Which indicates that in the case of second field the oscillator will get triggered a fraction of a second too soon as compared to the first field. Note that this inequality in potential levels for the two fields continues during the period of discharge of the capacitor. Once the vertical sync pulses are over and the horizontal-pulses take over. Though the actual time difference is quite short it does prove sufficient to upset the desired interlacing sequence.

To take care of this drawback which occurs on account of the half-line discrepancy five narrow pulses are added on either side of the vertical sync pulses. These are known as pre-equalizing and post-equalizing pulses.

**PRE-EQUALIZING PULSES**

Pre-equalizing pulses being of  $2.3\mu$  sec duration result in the discharge of the capacitor to essentially zero voltage in both the fields, despite the half-line discrepancy before the voltage build up starts with the arrival of vertical sync pulses.

**POST-EQUALIZING PULSES**

Post-Equalizing pulses are necessary for a fast discharge of the capacitor to ensure triggering of the vertical oscillator at proper time. If the decay of voltage across the capacitor is slow as would happen in the absence of post-equalizing pulses, the oscillator. may trigger at the trailing edge, which may be far away from the leading edge and this could lead to an error in triggering.

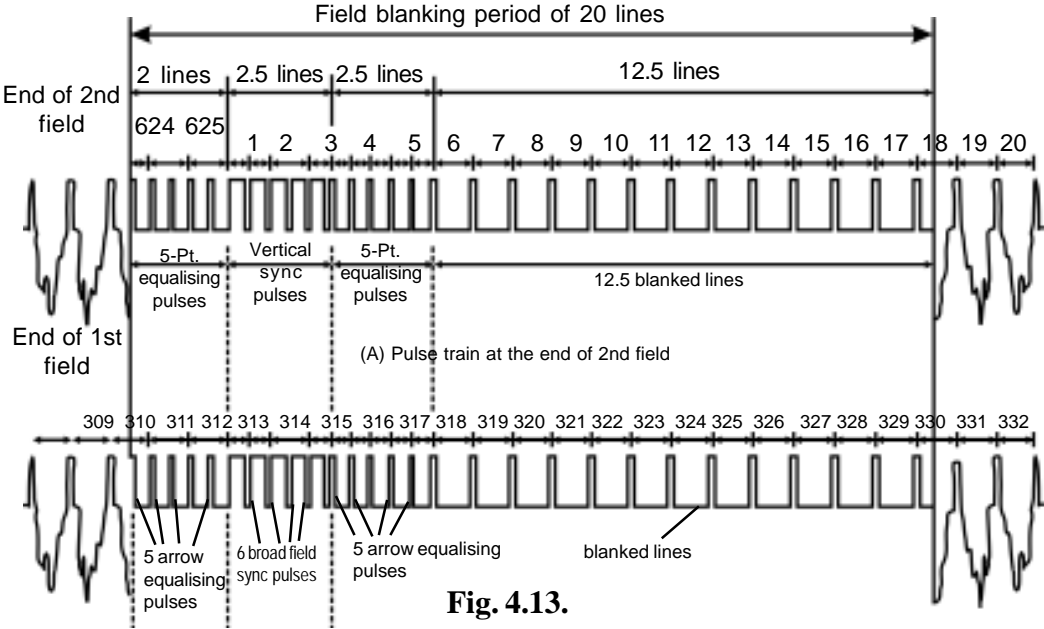

**Fig. 4.13.**

## VIDEO MODULATION

There are two types in Video modulation:

1. Positive Modulation
2. Negative Modulation

### POSITIVE MODULATION

When the intensity of picture brightness causes increase in Amplitude of the modulated envelope, it is called Positive modulation.

### NEGATIVE MODULATION

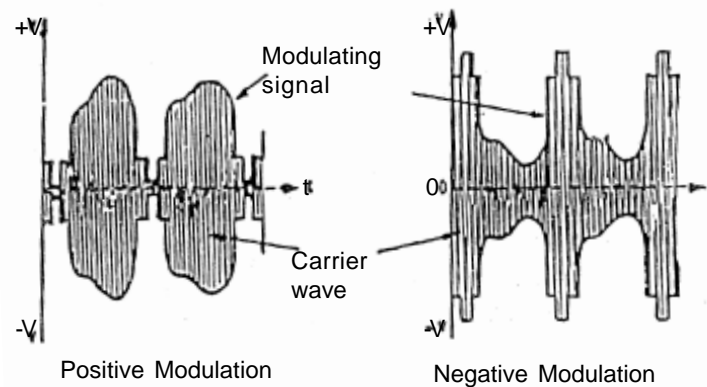
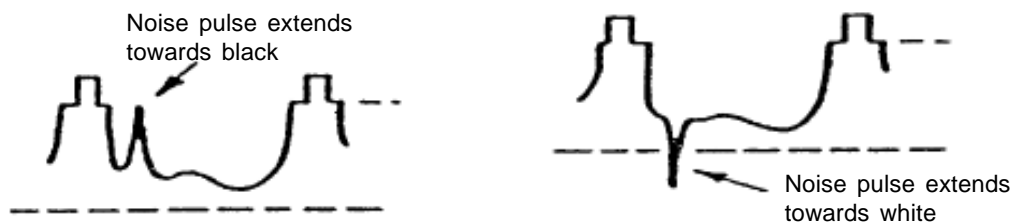

**Fig.4.14.**

When the polarity of modulating video signal is so chosen that sync tips lie at the 100% level of carrier amplitude and increasing brightness, produces decrease in the modulation envelope, it is called Negative modulation.

### ADVANTAGES OF NEGATIVE MODULATION

In this, due to noise black dots are formed with black back ground. This will have minimum effect than the white dots with white background in positive modulation.



**Fig. 4.15.**

### DISADVANTAGE

Impulsive interference may happen when there is change in signal strength.

### VSB TRANSMISSION

According to CCIR-PAL B method of transmission the video bandwidth is fixed to 5MHz. In order to transmit video signal in Single side band method, one side band has to be filtered. Since video signals are of high frequency one full side band cannot be filtered. Hence along with one side band another side band is attached. This method is called as Vestigial Side Band transmission.

## ADVANTAGES

1. Need of high band width is reduced.
2. Easy to filter one portion.

## DISADVANTAGE

There is some loss of power while filtering a portion of side band and also there may be slight phase and amplitude distortion.

## CHANNEL ALLOCATION FOR TV TRANSMISSION

Channel No	Frequency Range	Picture Carrier	Sound Carrier
2 VLR	47 to 54 MHz	48.25 MHz	53.75 MHz
3 VLR	54 to 61 MHz	55.25 MHz	60.75 MHz
4 VLR	61 to 68 MHz	62.25 MHz	67.75 MHz
5 VHF	174 to 181 MHz	175.25 MHz	180.75 MHz
6 VHF	181 to 188 MHz	182.25 MHz	187.75 MHz
7 VHF	188 to 195 MHz	189.25 MHz	194.75 MHz
8 VHF	195 to 202 MHz	196.25 MHz	201.75 MHz
9 VHF	202 to 209 MHz	210.25 MHz	215.75 MHz
10 VHF	209 to 216 MHz	210.25 MHz	215.75 MHz
11 VHF	216 to 223 MHz	217.25 MHz	222.75 MHz
12 VHF	223 to 230 MHz	224.25 MHz	229.75 MHz
UHF 21 to 69 Channels		470 to 890 MHz	

## 4.3 B/W TV PRINCIPLE COLOR TV PRINCIPLE

Television receivers can be classified into three types according to the devices used.

- 1) Valve type receivers
- 2) Solid state receivers
- 3) Hybrid type receivers

### VALVE TYPE TELEVISION RECEIVERS

Diode, triode and pentode valves are used in this type of TV receivers. 140 to 300 Volts power supply is required for its application. Since it is bulky and emissions of enormous heat, the next generation of TV receivers using semiconductors are designed.

### SOLID STATE TELEVISION RECEIVERS

These types of receivers were made of semiconductor diodes, transistors and ICs except picture tube. 12V to 110V power supply is required for the operation.

### HYBRID TYPE TELEVISION RECEIVER

In this type, the deflection circuits generate the power tubes, while the other circuits use transistor and ICs. Two dc sources; 140 to 300V for tubes, 12 to 40V for transistors are required.

Before going to know about the TV receiver circuits, first of all, we should know the stages and their functions.

## **10.1 BLOCK DIAGRAM OF A TV RECEIVER**

### **ANTENNA**

Yagi antenna is used for receiving television signals. It receives all the signals including noise, and fed to TV receivers.

### **RF TUNERS**

It consists RF amplifiers, mixer local oscillator, high pass filter and trap circuits. It selects the desired channel (VHF or UHF) and converts it into constant I.F. IF. signal contains video IF. 3 signals (38.9MHz) and sound IF signal (33.4MHz).

### **COMMON IF AMPLIFIER**

This stage filters noise and amplifies the two IF signals

### **VIDEO DETECTOR**

It filters the carrier signal and separates the composite video signal. **Video amplifier** It contains a device amplifier and an o/p amplifier. It amplifies the composite video signal to a large extent to feed 80V (p-p) level to the cathode of the picture tube.

### **PICTURE TUBE**

Here, video signal is converted into electron beam first and then line by line pictures using deflection stage.

### **AUTOMATIC GAIN CONTROL (AGC)**

AGC circuit controls gain of RF and IF stages to deliver almost constant signal gain to receiver, despite changes in the signal gain from TV station.

### **SYNCHRONIZING PULSE SEPARATOR**

It separates the synchronizing pulses from the composite video signal

### **DIFFERENTIATOR**

It separates horizontal synchronizing pulses from the synchronize pulses. It is a high pass filter circuit

### **AUTOMATIC FREQUENCY CONTROL (AFC)**

Fly back pulses from LOT and horizontal synchronizing pulses are compared here to deliver the difference of the above as dc control voltage to horizontal oscillator. Hence horizontal synchronize loss due to noise is eliminated.

### **HORIZONTAL OSCILLATOR**

The purpose of using this stage is to produce 15,265Hz horizontal frequency to enable horizontal scanning.

### **HORIZONTAL DRIVER AND OUTPUT AMPLIFIER**

Horizontal frequency is amplified by these two amplifiers to a large extent and fed to horizontal

deflection coils. These coils attain electromagnetic and deflect the electrons beam from the picture tube into scanning lines. Pictures are reproduced by the scanning lines.

### HORIZONTAL O/P TRANSFORMER

Extra High Tension voltage 18000 Volts AC is produced here and is converted into DC and then fed to the final anode of the picture tube.

### INTEGRATOR

Vertical type pulses are separated from Synchronizing pulses. For that it is designed as a low pass filter. These pulses are fed to vertical oscillator to avoid vertical Synchronize lose.

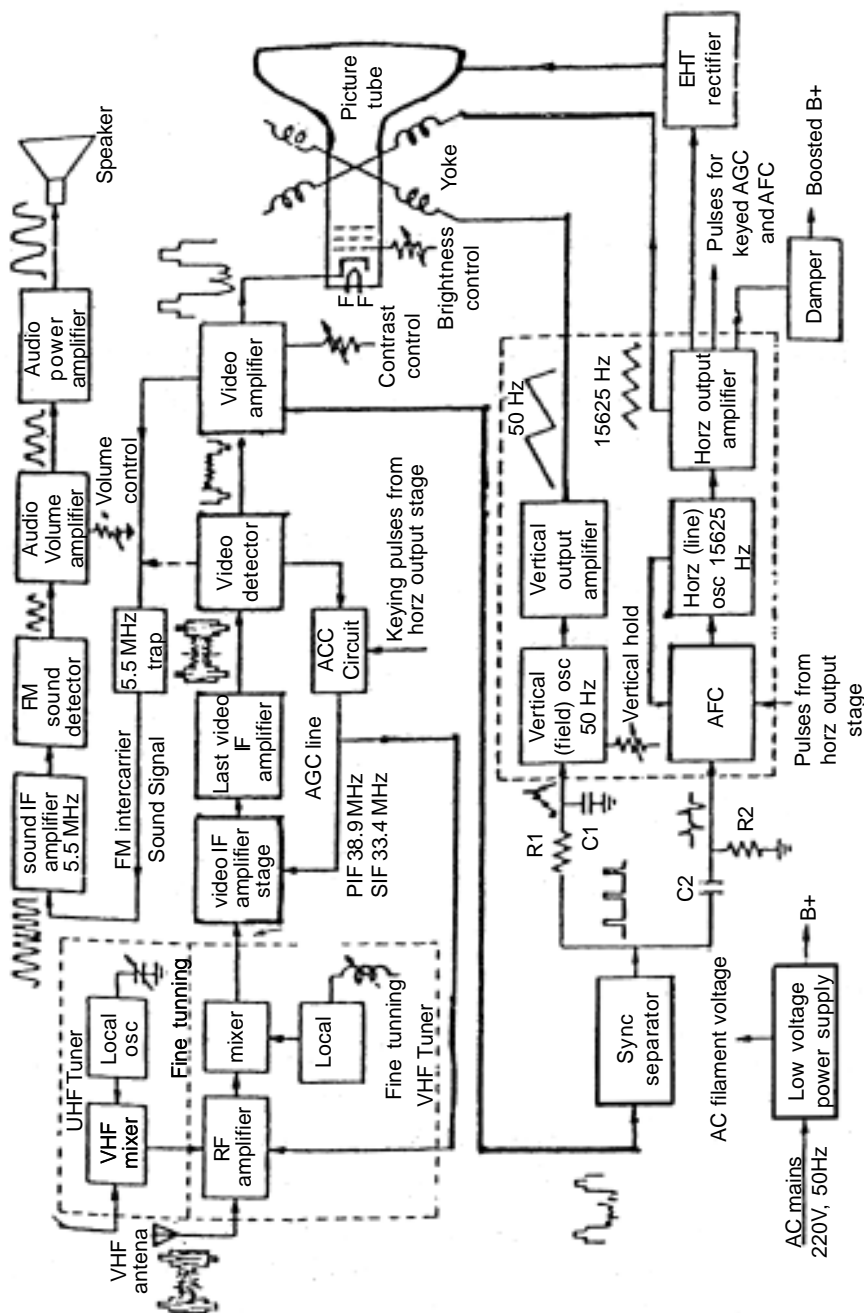

Fig. 4.16.

## VERTICAL OSCILLATOR

The purpose of using this stage is to produce 50Hz vertical frequency to enable vertical scanning

## VERTICAL DRIVES AND OUTPUT AMPLIFIERS

Vertical frequency is amplified and fed to the vertical deflection coils. These coils attain electromagnet and produce frames.

### Sound section

## 5.5 MHz TRAP CIRCUIT

5.5MHz inter carrier sound IF signal is separated by the 5.5MHz sound trap circuit

## SOUND IF AMPLIFIER

Sound IF signal is amplified and then its amplitude variations are controlled by amplitude limiter. FM detector circuit filters the carrier waves and separate the audio signal

## AUDIO AMPLIFIER STAGE

First, pre-emphasized audio signal is de-emphasized here and the audio signals are amplified to a large extent

## SPEAKER

It converts the audio signal into audible sound

## REGULATED POWER SUPPLY

Regulated power supply is classified into four type's viz. 1) SCR type 2) STR type 3) Transistor type 4) SMPS type. 110 volts and 12 volts are obtained from its output.

## COLOUR TELEVISION

It is very pleasant while thinking about color television. Because it shows the real and accurate colors of the picture. Earlier you have studied about the monochrome TV receiver. Now let us introduce the basics of color television to you.

The basic difference between monochrome and color televisions is the picture tube. In color television picture tube, there are three electron guns. Though a lot of colors, all the other colors are produced. On the basis of three colors, three electron guns are used.

Magenta, Cyan and yellow are complementary colors.

## MIXING OF COLORS

Mixing of colors is done in two methods. a) Additive mixing b) Subtractive mixing

### ADDITIVE MIXING

30% Red + 59% Green	=	Yellow (89%)
30% Red + 11% Blue	=	Magenta (41%)
11% Blue + 59% Green	=	Cyan (70%)
30% R + 59% G + 11% B	=	White (100%)

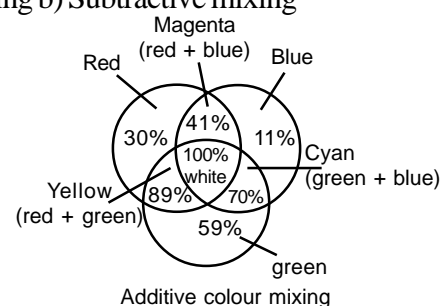

**Fig. 4.17**

## SUBTRACTIVE MIXING

White – Blue – Green	=	Red
White – Green	=	Magenta
White – Green – Red	=	Blue
White – Blue	=	Yellow
White – Blue – Red	=	Green
White – Red	=	Cyan

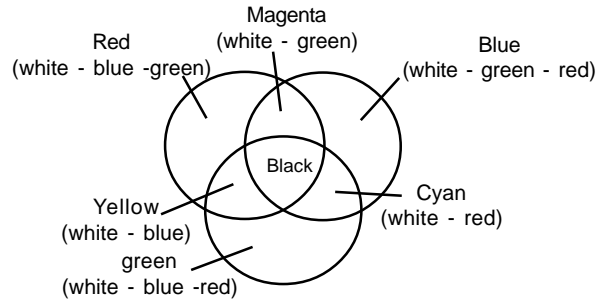

**Fig. 4.18**

Color matrix and color burst circuits are used for the mixing of colors.

America, Germany and France use different methods in developing an image. They are

1. American method – NTSC (National Television Systems Committee)
2. German method – PAL (Phase Alternation by Line)
3. French method – SECAM, (Sequential Color and Memory In Our country, PAL – B method is used.

## Fig. 4.18 Differences between PAL and NTSC

S.No	Characteristics	PAL B	NTSC
1.	Channel bandwidth	7 MHz	6 MHz
2.	Video bandwidth	5 MHz	4 MHz
3.	Inter-carrier sound IF	5.5 MHz	4.5 MHz
4.	Video IF	38.9 MHz	45.75 MHz
5.	Sound IF	33.4 MHz	41.25 MHz
6.	Lines/frame	625 lines	525 lines
7.	Horizontal frequency	15,625 Hz	15,750 Hz
8.	Frame frequency	5 frames/sec	30 frames/sec
9.	Field frequency	50 fields/sec	60 fields/sec
10.	Colour subcarrier frequency	4.43 MHz	3.58 MHz

## TUNERS

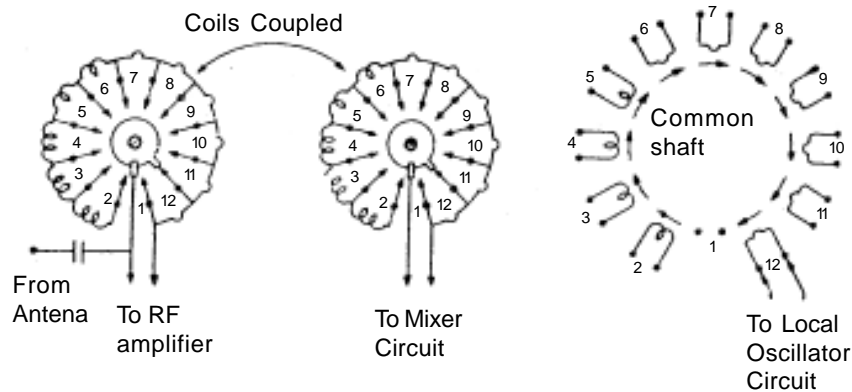

**Fig. 4.19**

All TV receivers have separate VHF and UHF tuners. The VHF tuner may be single channel or multi channel to cover all Band I and Band HI Channels. Normal switching methods of tuned circuit selection are not used because longer leads may cause parasitic oscillations. The VHF tuners are either turret type or rotary-wafer type.

## TYPES OF TUNERS

### Mechanical Type

- a. Turret type
- b. Wafer or Incremental type

### Electronic Type

- a. Stick type
- b. Thumb wheel type
- c. Digital type

## I) TURRET TUNER

The turret or drum type tuner is so named because coils for various channels are mounted on a slotted drum type structure that  $k$  rotated by the channel selector. The tuned circuits are mounted on separate strips for each channel which are clipped into the turret. The coils required are selected by rotating the turret thus maintaining the shortest possible length of connections. Each strip has coils for RF amplifier, mixer and local oscillator for a single channel. The schematic of a VHF turret tuner shown in Fig illustrates the manner in which a coil-strip on the drum makes connections with the rest of the circuit.

## II) WAFER OR INCREMENTAL TUNER

This tuner employs a wafer switch type construction where a tier of wafer switches permits selection of the proper RF, mixer and oscillator coils. The coils are usually mounted around the outer rim of the switch with a few turns of wire for the lower channels and progressively decreasing for the higher channels. The wafer switch is rotated to connect one set of RF, mixer and oscillator coils for each channel Fig shows schematic of VHF tuner-wafer switches. Note that the coils for RF amplifier, oscillator and mixer stages are on separate wafer switches ganged on a common shaft. The oscillator coils are always on the front section for convenience of adjusting the inductance to set the frequency.

The wafer type tuners are also called incremental tuners because the change of channel is accomplished by a progressive shorting of sections of the total inductance. For channels 2 to 6 individual coils are connected in series and are progressively shorted out. For channels 7 to 11 only a single turn or half a turn is sufficient for tuning.

Channel I is not assigned for TV broadcasting any more and this position on the selector switch is generally used to turn on the UHF  $A$  tune. The recent version of tuner wafer construction utilizes a printed I circuit wafer. In this method all coils for higher channels are replaced by printed circuit inductances. This method has the advantage of greater reliability, greater uniformity of alignment and lower cost.

## ELECTRONIC TUNING

Varactors or varicaps are used for electronic tuning in tuner circuits Varactor is a special silicon diode, the junction capacitance of which is used for tuning. The capacitance varies inversely with the amount of reverse bias applied across the diode. The resonant frequency of the tuned circuits in which they are connected, is controlled merely by changing the reverse bias across the varactor:



## **STICK TYPE**

A plastic stick is used to adjust the value of the variable resistor so as to vary the voltage from 0-33 V.

## **THUMBWHEEL TYPE**

A tuner setup which has plastic wheels, can be rotated by using our thumb.

## **DIGITAL TYPE**

Micro processor is used in this type, to adjust the voltage from 0-33 V to the varicap diode for tuning.

## **CHANNEL TUNING**

There is a separate adjustment for each channel. Resonance is achieved with distributed capacitance of the coil, stray and trimmer capacitors. For fine tuning the oscillator coil is usually constructed with an aluminum or brass screw as the core. Inductance decreases with aluminum or brass core because of eddy currents in the metal. The screw is turned by a plastic gear wheel which is engaged when the fine tuning control is pushed-in against the holdings springs. The frequency variation thus obtained is enough to tune in the next channel station.

Some receivers employ automatic frequency running (AFT) where an automatic frequency control is applied to the local oscillator in the tuner. Such circuits are discussed in a separate chapter devoted to special circuits.

## **VARIOUS SECTIONS OF A VHF TUNER**

As shown in Fig the tuner consists of the following sub-sections

### **WORKING OF THE TUNER**

The Tuner must have an input impedance equal to the characteristic impedance of the antenna feeder for maximum signal transfer to the tuner and to avoid reflections on the line. The balun matches the twin wire ribbon feeder impedance of 300 ohms to the 75 ohm impedance of RF amplifier. It consists of two 150 ohm ( $Z_0$ ) quarter-wave sections of bifilar windings on a ferrite core. As shown in Fig, at one end the two quarter-wave lines are connected in parallel to give 75 ohm impedance and at the other end they are connected in series to provide an impedance equal to 300 ohms. If a coaxial cable is used to connect the antenna to RF amplifier an identical parallel arrangement can be used on both sides of the balun to provide the match. Either side of the balun can be used for input with the opposite side for output.

The RF amplifier is designed to provide adequate gain to weak - signals. It is essential to maintain a high signal-to-noise ratio at the mixer which generates lot of noise. The equivalent noise voltage at the input of the RF amplifier sets a limit to the minimum signal strength that should be received to avoid excessive snow effects. As already stated RF amplifier besides providing gain to the selected channel signals (i) prevents radiation from the local oscillator and (ii) rejects image frequency signals.

The local oscillator generates an unmodulated sinusoidal (Carrier Wave) voltage that is heterodyned in the mixer with the incoming RF signal to affect its frequency translation to the IF band. The local oscillator frequency is changed when ever a different channel is selected to 'maintain difference equal to

the intermediate frequency between the local oscillator frequency and the tuned channel carrier frequency. The fine tuning control allows the oscillator frequency to be varied over a narrow range.

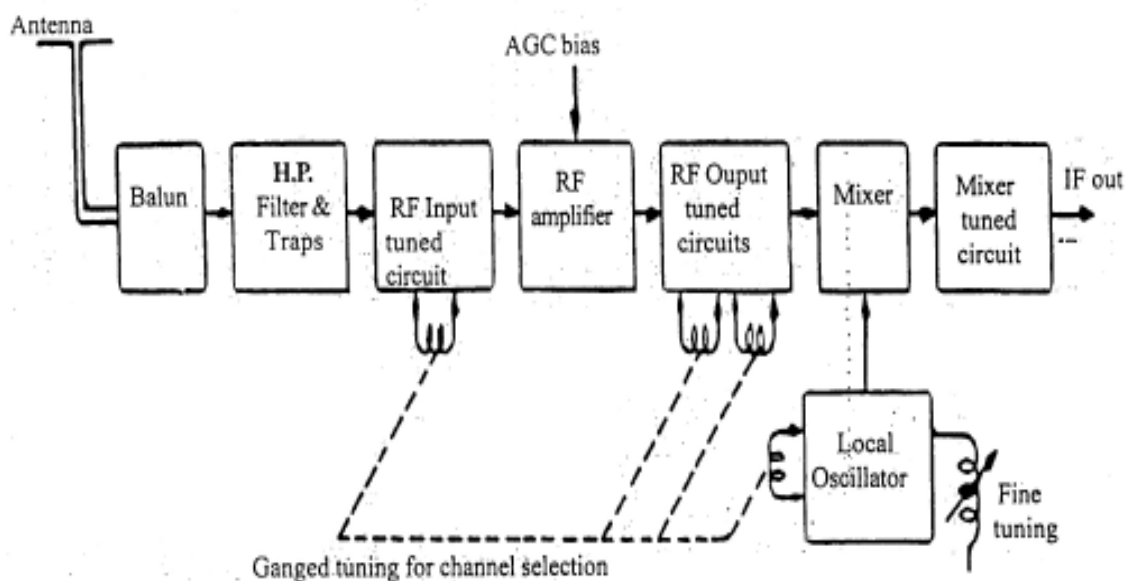

Fig. 4.20

The function of this circuit is to convert the incoming RF signal frequencies from different channels into a common IF pass-band of the receiver. This is achieved in the mixer by heterodyning or beating the local oscillator frequency with the signal obtained from the RF amplifier. The mixer stage, combined with the local oscillator, may be considered as a frequency converter.

### EXAMPLE

The band width for channel rv is 61 - 68 MHz. The picture carrier present after the first portion of the bandwidth (after 1.25MHz).

i.e Picture carrier is  $61 + 1.25 = 62.25$  MHz.

The sound carrier present in the last portion of the bandwidth\* (before the last 0.25MHz).

i.e The sound carrier is  $68 - 0.25 = 67.75$  MHz

Local oscillator frequency = 101.15 MHz

VIF = Local Oscillator frequency - Picture carrier  
 $= 101.15 - 62.25$

VIF = 38.9 MHz

SIF = Local Oscillator frequency - Sound carrier  
 $= 101.15 - 67.75$

SIF = 33.4 MHz

### IF WAVE TRAPS

A wave trap is a resonant circuit tuned to attenuate a specific frequency. Basically there are five types of trap circuits used at the input of the video IF amplifiers. These are (a) series tuned, (b) parallel tuned (c) absorption type, (d) degeneration type and (e) bird configurations.

**a) Series trap circuit** - The series trap is a parallel resonant circuit. It offers very high impedance at the rejection frequency to which it is tuned. It is connected in series between two IF stages as shown in Fig. Since the trap is a sharply tuned-circuit designed to reject one frequency or at most, a narrow

band of frequencies, it offers negligible impedance to all other frequencies and thus the desired signal is passed without any attenuation.

**B) PARALLEL TRAP CIRCUIT** - This trap is a series resonant circuit connected in shunt with the path of the IF signal. Its impedance is very small at the frequency to which it is tuned. It thus acts as a short at the frequency that is to be rejected and by passes it to ground. Its connection in the IF stage is illustrated in Fig. It is important that the parallel trap circuit has a very high Q so that it rejects only a narrow range of frequencies.

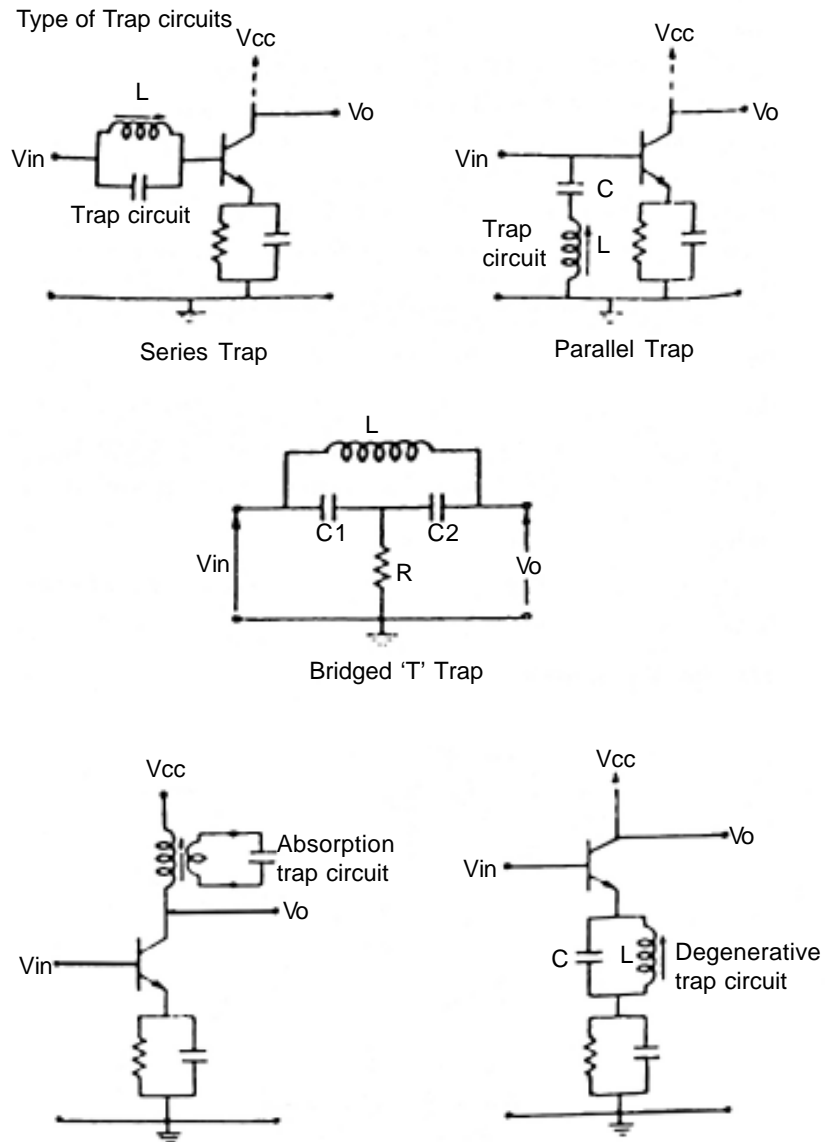

**Fig. 4.21**

**C) ABSORPTION TRAP CIRCUIT** - The absorption trap circuit shown in Fig is inductively coupled to the plate or collector load inductance of the IF stage. The trap is tuned to the frequency that is to be rejected. As a result, at this frequency maximum current flows within the trap circuit. Since the trap circuit draws energy from the tuned load coil, a sharp decrease in the Q of the tuned load circuit occurs with the result that the stage gain at the undesired frequency is very much reduced. This amounts to a large attenuation at the frequency to which the absorption trap is tuned.

**D) DEGENERATIVE TRAP CIRCUIT** - This circuit, illustrated in Fig applied a large negative feedback to the IF amplifier at the frequency to be rejected. A parallel L-C circuit is inserted in the cathode or emitter lead of the tube or transistor employed in the IF stage. The circuit is tuned to the frequency that is to be attenuated. Thus, at resonance, it develops a large voltage across it which results in a sharp fall in the gain because of the degenerative action. At all other frequencies the impedance of the trap circuit is very small and hence practically no degenerative feedback occurs at these frequencies.

**E) BRIDGED TRAP CIRCUIT** - The circuit configuration of a bridged 'T filter is shown in Fig. The special feature of this circuit is that the value of R is so chosen that it effectively cancels the coil resistance. Then the parallel resonant circuit formed by L, C, and  $C_2$  attains a very high Q. The value of L, C, and  $C_2$  are suitably chosen to reject the desired frequency. Because of the large effective Q, this network is highly selective. It is input in series with the signal path and the slug in the trap coil is varied for minimum output. An attenuation of the order of 40 db can be easily attained if necessary. The circuit is another version of this trap circuit. The bridged 'T' trap is most widely used because of its highly selective attenuation characteristics.

### SAW FILTER

Surface Acoustic Wave filters is the expansion of SAW filter. It is a solid state device, which is used instead of wave trap circuits.

### MERITS

Complicated alignment is not needed. Small in size. Low cost. Crystal clear picture is obtained.

### 4.7 VIDEO STAGES

This stage is employed between Tunes and Video detector stages. Video IF (38.9 MHz) and sound IF (33.AMHZ) signals are feed as the input for this stage. Generally three stage IF amplifiers are used. So, AGC voltage to first IF stage and the overall gain is controlled. This stage is designed as a transformer coupled amplifier. Wave trap circuits are used in the input of this stage.

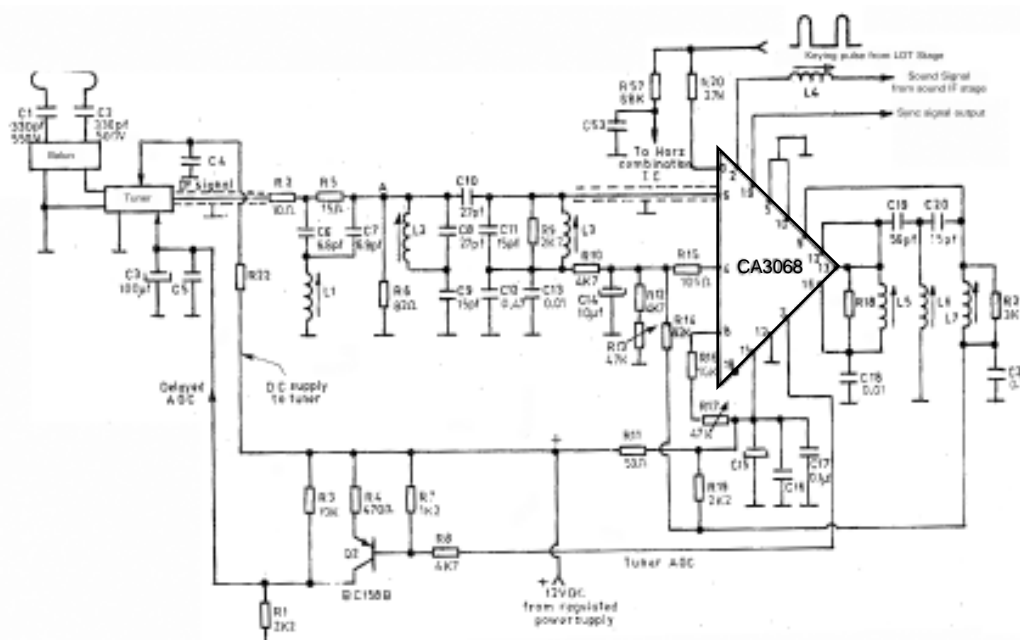

Fig.4.22

## FUNCTIONS

1. It amplifies video IF signal to a desired level.
2. But sound IF signal is amplified to a 5% of maximum gain.
3. This type increases the selectivity and sensitivity of the TV receiver.

Basic video IF amplifier circuit is shown in the figure, required signals are selected and the unwanted signals are rejected by the wave trap circuit. The input signals are fed through shielded cable to avoid stray capacitance. These amplifier uses stagger tuning. In this method, three coils are tuned to different response. The amplified IF signal is fed to the video detector stage.

## VIDEO DETECTOR

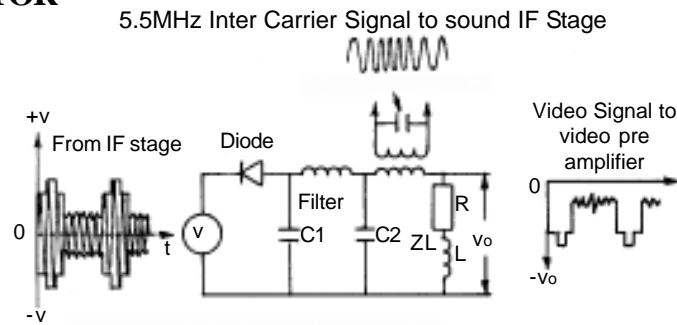

**Fig.4.23**

The main function of this circuit is to filter the carrier waves from the video IF signal and separates the composite video signal. Diode D is connected in series with the secondary of last IFT  $C, L, C_2, L_2$  C, i constructed as two II filters.

## CIRCUIT OPERATION

Diode D conducts only during the negative half cycle of the video IF signals from the secondary of the last IFT. The two n filter circuits filters the carrier waves in the negative half cycle. Thus, composite video signal is separated and its voltage is about 2 V (p-p).

Another function is also carried out in the diode D. That is, video carrier wave (38.9MHz) and sound carrier wave (33.4MHz) is mixed here. While mixing take place the output is obtained as the difference between the two- i.e. 5.5MHz as intermarried sound trap circuit and fed to the sound IF amplifier.

## VIDEO AMPLIFIER

It contains a device and an output amplifier.

## FUNCTIONS

1. Video signal is amplified to a maximum level and about 80V(p-p) level signal is fed to the cathode of picture tube.
2. It turns off during the retrace periods to blank retrace lines

There are four methods of coupling a video amplifier to the cathode of picture tube.

1. Direct coupling
2. Partial dc coupling
3. AC coupling
4. AC coupling with dc retraction



## **MERITS**

1. Very good high frequency response
2. The black, white and grey levels of picture is maintained to a desired level
3. Protects the picture tube by controlling beam current.

## **DEMERITS**

1. Regulated EHT supply is needed. Because at peak white levels, beam current increases and as a result EHT voltage decreases. In turn, balancing occurs. A well regulated EHT supply reduces this effect.
2. Beam current limiter should be used. Because the picture tube is driven to a high brightness level if the input video signal is absent and it reduces the life of picture tube.
3. Due to the very good low frequency of the amplifier, a momentary flutter of the reproduced picture is resulted because of the fluctuating RF signal gain. while the passing of aero planes. Despite an efficient fast acting AGC, this effect cannot be eliminated completely.

## **KEYED AGC**

### **CONSTRUCTION**

This circuit turns 'ON', only when the input video signal and fly back pulses are present and gives AGC voltage. It runs off during the absence of the signals. These signals act as a key. Hence this circuit is called as keyed AGC. Fly back pulses are also termed keying pulses. Fly back pulses having a value of 25V (p-p) from horizontal output transformer is rectified by IN4148 and a negative voltage is given to the collector of the transistor. From detector stage, a negative video signal having a value of 2 V (p-p) is obtained and applied to the base of the transistor. The positive voltage required for the emitter is given from 12 Volts supply through AGC preset

### **CIRCUIT OPERATION**

During the conduction of transistor, peak synchronizing pulses of 2 V(p-p) video signal is amplified and obtained at the collector. The current flows through the diode and winding of LOT. It results in charging of capacitor C, (since it is reverse biased). About 1.5 to 4V AGC voltage is obtained.

## **DELAYED AGC**

First of all, AGC voltage is applied to IF amplifier and thus signal gain variations' are controlled. For the maximum reduction of noise, amplification in RF stage should be maximum. If a low gain RF signal is obtained, AGC voltage is delayed and then feed to the RF amplifier. Hence, RF signal is amplified to a maximum and noise is thus reduced.

## **MERITS OF KEYED AGC**

1. Noise is reduced because the transistor becomes 'on' during the horizontal balancing period only and at other times, it becomes 'off'.
2. Since short time constant AGC capacitor, AGC voltage is obtained even if a rapid variation in signal strength (interference due to the passing of aero planes) and enable RF and IF amplifier to maintain in signal strength constant.
3. This type of AGC fast by reacts during fast change of stations and maintain constant signal gain to produce stable picture and sound.

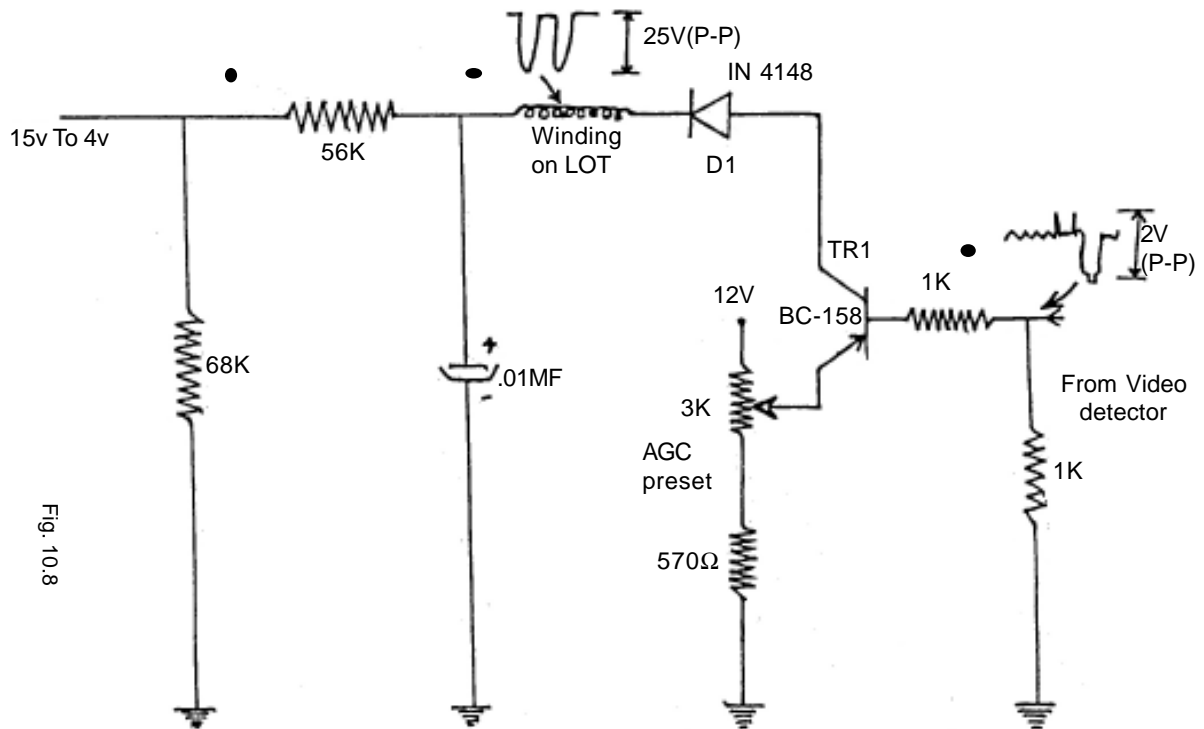

Fig.4.24

### CATHODE RAY TUBE BIASING (CRT BIASING)

The cathode of the picture tube is fed 80V (p-p) video signal. The tungsten filament is given 6.3 V AC. Hence cathode is indirectly heated and emits a lot of electrons.

Control grid (G<sub>1</sub>) is biased with 0-50V DC, through brightness control. Thus variation in brightness is obtained. Brightness control is a variable resistor, its value being 470KΩ

Accelerating grid (G<sub>2</sub>) is given 150V DC. It accelerates the velocity of electrons. The focusing grid biased with 100V, focuses the electron beam into center of the screen.

Final anode is biased with 1800V DC. It helps to increase the speed of electrons. Thus the phosphor screen is illuminated to produce light.

Interlaced scanning takes place by the horizontal and vertical deflection coils which are placed in the neck of the picture tube. Hence full raster (light) is obtained.

A spark gap capacitor (0.6pf/2KV) is used in cathode and grids. It bypasses the arcing between the electrodes and protects the picture tube.

The capacitor which is earthed from G<sub>1</sub> delivers beam current even after the receiver being switched off to discharge EHT voltage and eliminates "switch off spot".

Interlaced scanning takes place by the horizontal and vertical deflection coils which are placed in the neck of the picture tube. Hence full raster (light) is obtained.

A spark gap capacitor (0.6pf/2KV) is used in cathode and grids. It bypasses the arcing between the electrodes and protects the picture tube.



## 4.8 SYNC STAGE SAND DEFLECTION UNIT CONSTRUCTION

Its main function is to separate the synchronizing pulses (shortly sync, pulses) from the composite video signal. Class C amplifier is employed for that purpose.

Peak sync pulses from the positive base bias voltage of Q and is amplified and obtained at the collector. Here both the vertical and horizontal sync, pulses are obtained.

Both C, R, act as a high pass filter to separate horizontal sync, pulses. It is also called as differentiator horizontal sync, pulses are fed to horizontal AFC stage C<sub>2</sub> act as a low pass filter to separate vertical sync, pulses. It is also called as Integrator vertical sync, pulses are fed to the vertical oscillator.

Noise due to car ignition and mains supply spark causes sync pulses. As a result, the picture would jitter or tear. So, noise must be eliminated here,

Both filters reduce noise. Hence stable picture is obtained.

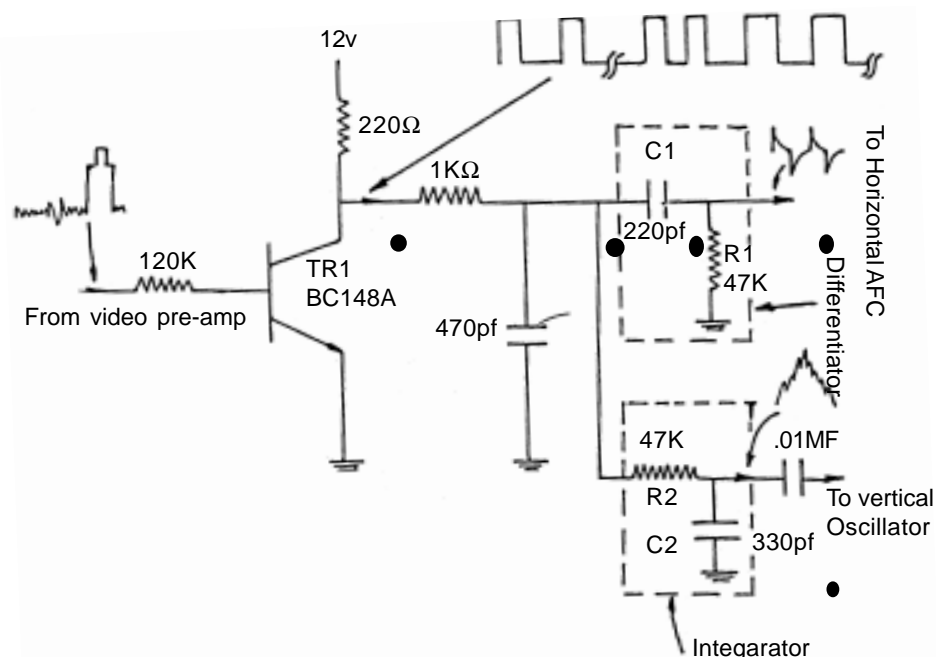

Fig.4.26

### AUTOMATIC FREQUENCY CONTROL (AFC)

This stage automatically controls the variations in horizontal frequency. Hence it is called Automatic Frequency Control.

#### CONSTRUCTION

Horizontal sync pulses are applied at the common cathode ends. Fly back pulses from LOT is converted as saw tooth waves and fed in series with the diodes.

#### OPERATION

In opposite and equal voltage is obtained at the common cathode of two diodes. If the difference between the horizontal sync and fly back pulses, high output voltage is also low. The output of AFC is pulsating dc.

C, R, C<sub>2</sub> act as AFC filter and converts it into pure Dc. This is called as AFC control voltage. This control voltage locks the horizontal oscillator to enable it to maintain 15,625Hz constant. Hence horizontal rolling of picture and beaming are received and a stable picture is obtained.

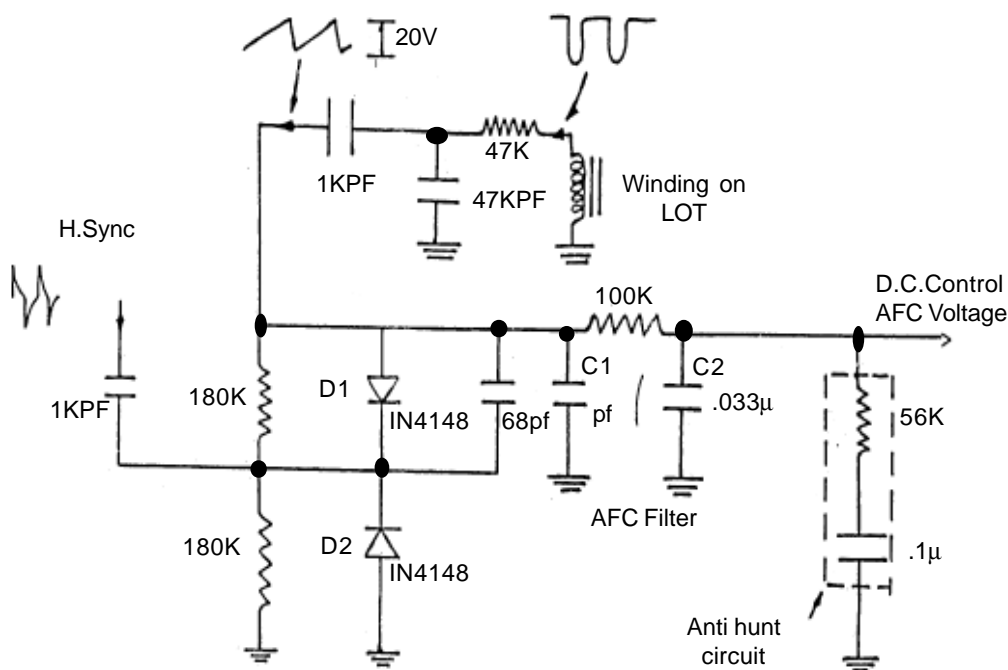

Fig.4.27

## HUNTING

AFC filter offers control voltage slighter delayed. This is referred as Hunting. As a result, gear tooth effect is produced in the picture. To avoid this, an anti circuit, contains 56K and 0,1 is used.

## HORIZONTAL DEFLECTION OSCILLATOR

A multivibrator is another type of relaxation oscillator which employs two amplifier stages, where the output o one is coupled to the input of the other. This results in overall positive feedback and the circuit operates such that when one stage conducts, it forces the other to cut-off. Soon the stage that cuts off returns to conduction to force the first stage to cut-off. This sequence repeats to generate square or rectangular output with a frequency that is controlled by the coupling networks between the two amplifier stages. As in the case of a blocking oscillator the multivibrator is used as a controlled switch to charge a capacitor through a resistance to generate the required saw tooth wave output. The amplifier may employ tubes or transistors as active devices.

Multivibrators may be classified as bitable, constable and actable. A bitable multivibrator has two stable stages and needs two external trigger signals to complete one cycle of oscillation. The constable type has one stable stage and completes one cycle of output with only one external pulse. However, as table multivibrator is a free running type and does not need any external trigger pulse for its normal operation. It is this type of multivibrator that is employed as a deflection oscillator and its frequency is synchronized with the horizontal AFC Voltage or vertical sync pulses. Multivibrators can also be classified on the basis of coupling between stages. The two types that are used in TV receivers are plate (or Collector) coupled and cathode (or emitter) coupled.

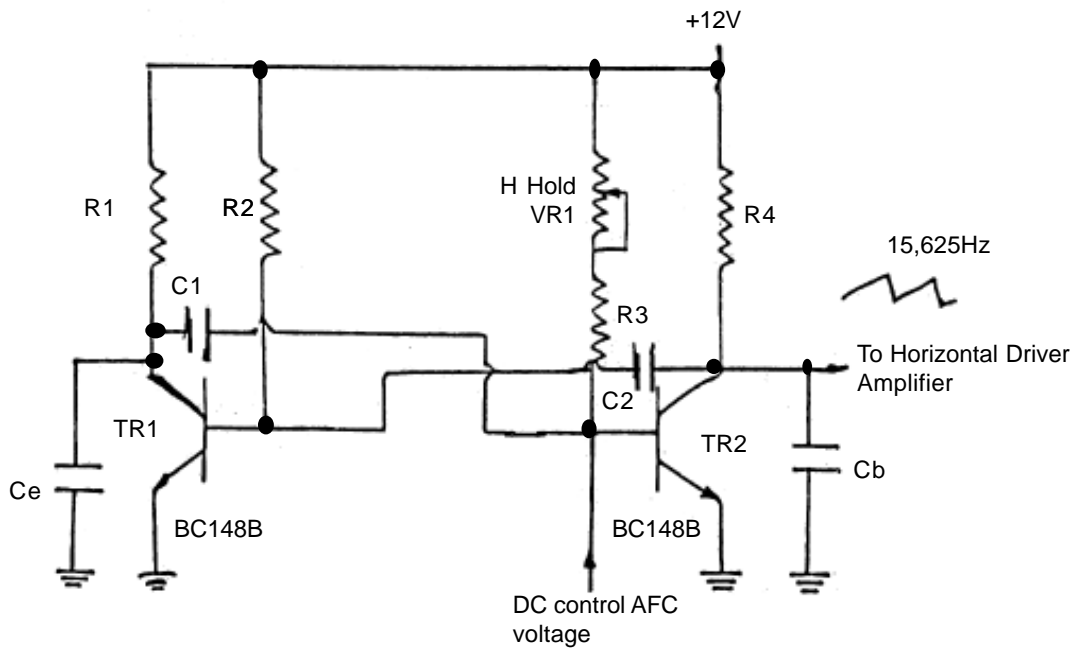

**Fig.4.28**

The circuit configuration shown in Fig is of a free running collector coupled multivibrator where two common emitter amplifiers are cross coupled to provide positive feedback. Note that the base resistance The circuit operation can be easily explained if the sequence of operations is followed from the instant when one transistor just conducts and the other goes to cut-off.

Fig illustrates the collector and base voltage waveforms for one complete cycle. At the instant marked  $t_0$  transistor  $Q_2$  just conducts to saturation and transistor  $Q_1$  returns to cut-off. As this happens, the rising voltage at the collector of  $Q_1$  charges the capacitor  $C_2$  to  $V_{cc}$ . Since  $V_B$  The charging current of  $C_2$  flows through the base of  $Q_2$  to complete its circuit.  $R_{B2}$  is elected to provide enough current from  $V_{cc}$  to the base of  $Q_2$  to keep it in saturation, even when the charging current of  $C_2$  becomes zero and  $C_2$  charges to  $V_{cc}$ .

In a similar manner  $C_1$  would have got charged to  $V_{cc}$  in the previous cycle when  $Q_2$  was in saturation. Actually at  $t = t_0$  the capacitor  $C_1$  which was previously charged to  $V_{cc}$  gets earthed with its positively charged plate towards ground, the moment,  $Q_2$  goes into full conduction. As shown in Fig C, is then in parallel with emitter-base junction of the 'off' transistor  $Q_1$ . This puts a reverse bias on  $Q_1$  equal to  $-V_{cc}$  at  $t = t$  which is well beyond cut-off bias of the transistor.

The capacitor  $C_1$  now starts charging from  $-V_{cc}$  towards  $+V_{cc}$  as shown in Fig. At  $t - t$ , the negative voltage across  $C_1$  reduces to zero and permits base current flow in the transistor  $Q_1$ . This action is regenerative and  $Q_1$  instantly goes to saturation which intum cut-off  $Q_2$ . The time constant  $R_{B1}C_1$  controls the off period ( $t - t_Q$ ) of  $Q_1$ , and can be set equal to the retrace period of the required saw tooth wave.

The moment  $Q_1$  goes into saturation the positively charged plate of  $C_2$  is effectively grounded through  $Q_1$ . It then begins to charge towards  $+V_{cc}$  at a rate determined by the time constant  $R_{B2}C_2$ . Once again when  $V_{C2} = 0$ , the second transition takes place to complete one cycle of operation. This cycle then repeats and permits the circuit to function as a free running multivibrator. The time constant

$R_{B2}C_2$  can be made equal to the trace period. As shown in the circuit,  $R_{B1}$  consists of R1 and R where  $R_2$  is a potentiometer to adjust the retrace period and thereby controls the frequency of the multivibrator.

### HORIZONTAL DEFLECTION SECTION

It contains a driver and an output amplifier. Horizontal frequency is amplified by the two amplifiers and fed to the horizontal deflection coils and produce horizontal scanning.

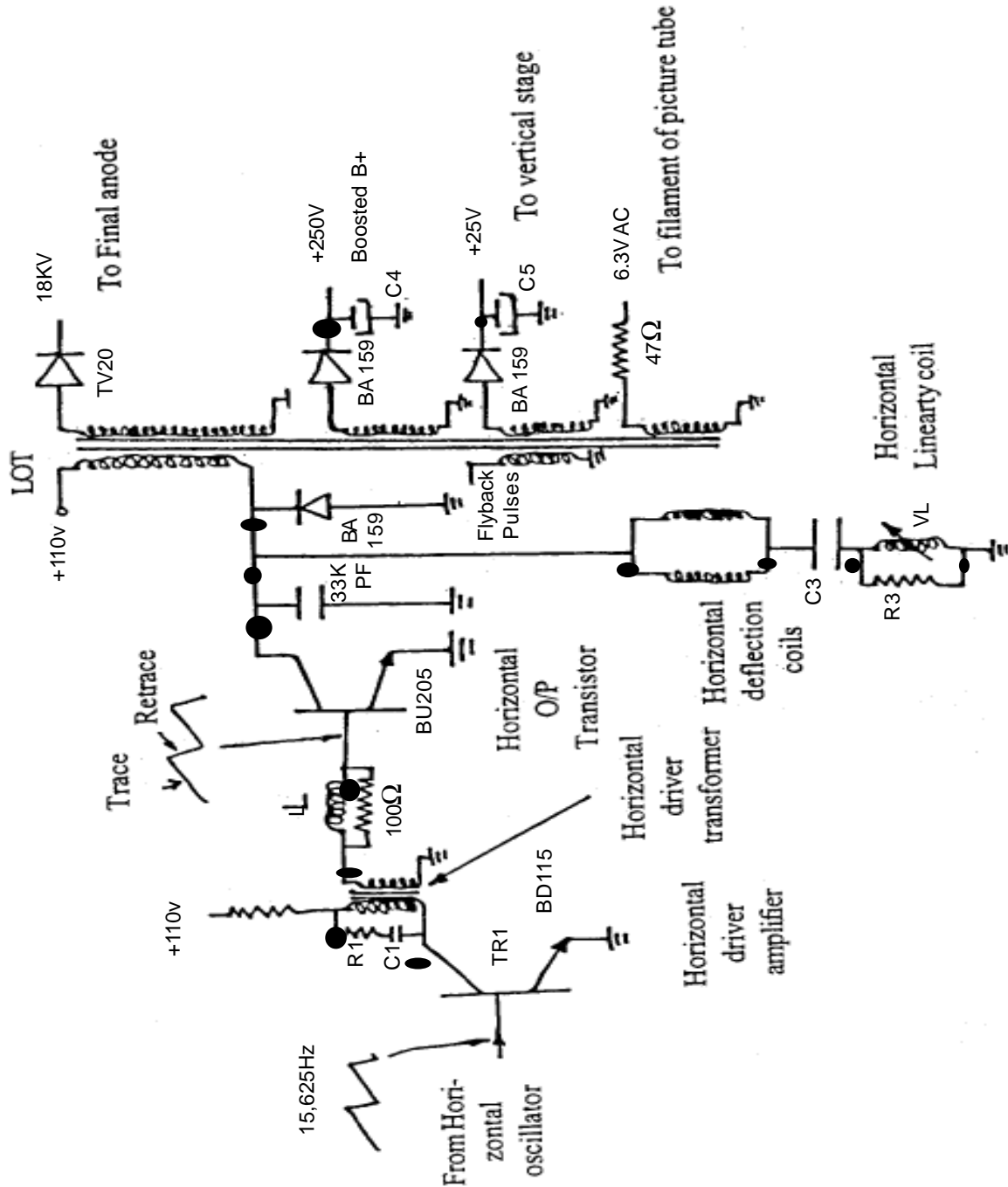

Fig.4.29

## CONSTRUCTION AND CIRCUIT OPERATION

Horizontal frequency 15,625Hz from the horizontal oscillator is fed to the horizontal driver transistor BD115. The collector voltage is supplied through  $R_t$  and primary of driver transformer. Emitter is being earthed.

BD115 amplifies the frequency and gives it to the base of the output transistor BU205. 110V is supplied to the collector of BU205 through primary of Line Output Transformer (LOT). Emitter is being earthed.

BU205 conducts during trace period and in retrace period it does not.

During the conduction, an electromagnetic field is developed in the primary of LOT. When the transistor goes off, the electromagnetic field collapses and thus induces a 6KV at the center of the primary. Due to mutual induction, the LOT steps up to produce an extra high voltage of 18000Volts. This EHT voltage is rectified by a rectifier namely TV20 and fed to final anode of picture tube. Also, LOT produces boosted  $B^+$  of about +250V to bias the grids of picture tube. Hence power supply to various stages is taken from LOT, it is also named as auxiliary power supply.

## DAMPER DIODE

During the conduction of BU205, self oscillations are produced in the LOT. The negative half cycle of this oscillation is earthed by damper diode. Hence energy loss in horizontal output mostly recovered. So it is also called as energy recovery diode.

## LINE OUTPUT TRANSFORMER

It operates on stepup and stepdown methods. Since it is used in high frequency, ferrite core is adopted. It is heavily insulated with plastic, because it handles a very high voltage.

The other names of Line Output Transformers

1. Flyback Transformers
2. Extrahigh tension Transformers
3. Horizontal Output Transformers

## VERTICAL OSCILLATOR

A sawtooth wave of 50Hz is needed for vertical scanning. This stage produces 50Hz waves.

## CONSTRUCTION

It belongs to the ramp generator type oscillator.  $R^1$  (100K) and C (0.47mfd) are used as time constants. Biasing voltage from +25 V supply is fed to the base of transistor -Q through VR, and  $R^2$  and to the collector through  $R_3$  and  $R_4$ . Vertical sync pulses are given by the integrator stage through C, A positive feedback is applied to the base of Q, through R, and  $C_2$ .

## CIRCUIT OPERATION

After supply is given,  $C_3$  starts charging through  $R_j$ . 50Hz sawtooth waves are produced due to the discharge of  $C_3$  and feed to the vertical driver and output amplifier and amplified. A feedback is given from the output stage to its input. Hence undamped 50Hz waves are produced. If the base voltage is varied by variable resistor VR, collector current varies. It alters the time of charging and discharging of  $C_y$ . Using this, we can alter the frequency produced.

$VR_1$  acts as V Hold control and helps to produce constant 50Hz saw tooth waves. We can control the rolling of picture using V hold control.

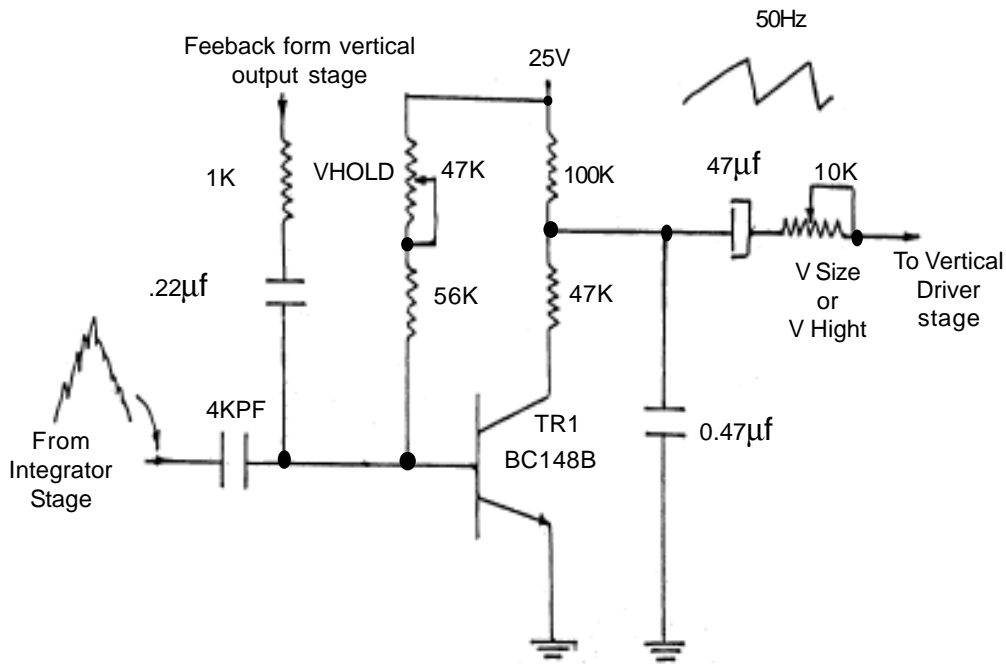

**Fig.4.30**

During transmission, vertical sync pulses from the integrator synchronize the vertical oscillator to produce stable picture.

A preset is used as V size or V Height ( $VR_2$ ). By varying this, we can increase or decrease the height of the picture.

## VERTICAL DEFLECTION SECTION

It contains a vertical driver and an output amplifier.

### CONSTRUCTION

50Hz waves from vertical oscillator are fed to the vertical driver  $Q_1$ . Its output is coupled to the base of  $Q_2$ . A supply of +25V is applied to the collector of  $Q_2$  through  $VR_1$ , and to the base of  $Q_3$  through  $R_1$  and  $R_2$ . The base of  $Q_2$  is connected at the junction of  $R_1$  and  $R_2$ . The emitters of  $Q_2$  and  $Q_3$  are coupled by  $R_3$  and  $R_4$ . The collector of  $Q_3$  is being earthed. Capacitor  $C_1$  is placed between the junction of  $R_3$  and  $R_4$  and  $R_5$  and  $R_6$ . The output is taken from the junction of emitters is fed to the vertical deflection coils.

### CIRCUIT OPERATION

50Hz saw tooth waves from the oscillator is amplified by  $Q_1$  and given to the base of  $Q_2$  and also to the base of  $Q_3$  through  $R_1$ . Since biasing voltage is given to  $Q_2$  and  $Q_3$  from +25 V supply, during the trace period of saw tooth wave,  $Q_2$  forward biased and  $Q_3$  reverse biased. So,  $Q_2$  conducts and amplifies the trace of saw tooth wave. On the other hand,  $Q_3$  turns off.

During retrace,  $Q_3$  forward biased while  $Q_2$  reverse biased. So,  $Q_3$  conducts and amplifies the retrace wave.  $Q_2$  turns off.

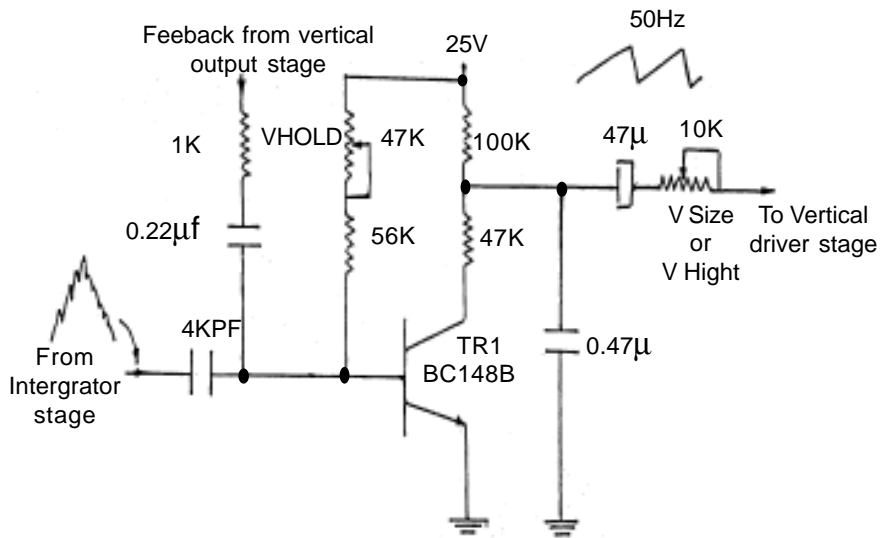
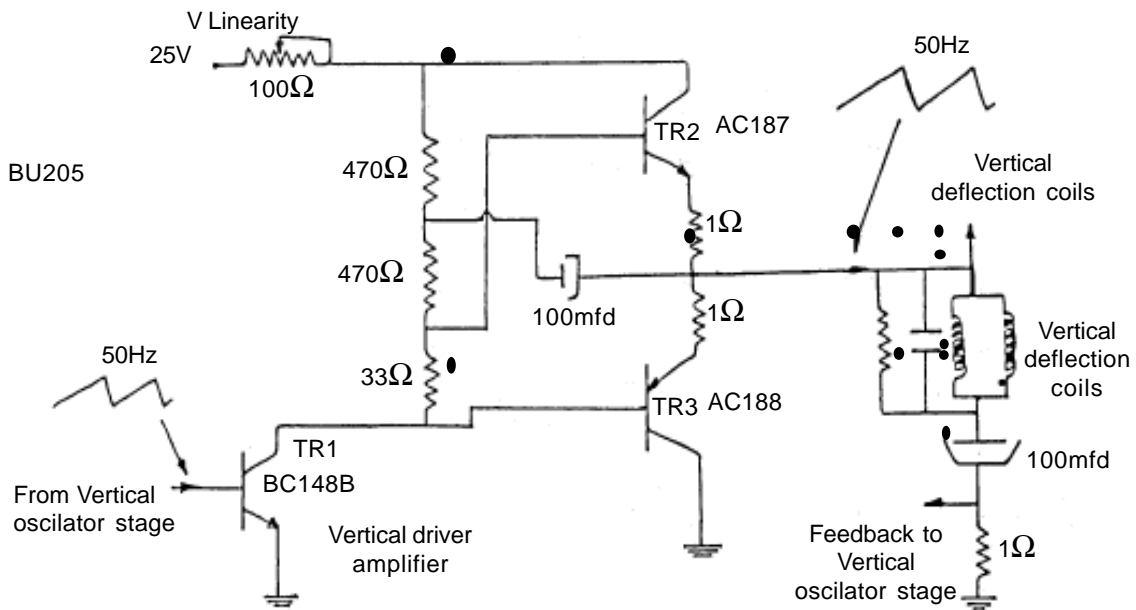

**Fig.4.31**

Since one transistor is pushed to conduction and another is pulled from conduction to off state, this type of amplifier is called as push pull type amplifier.

Amplified saw tooth wave are taken from the function of emitters and fed to the vertical deflection coils. Hence vertical scanning takes place.

A feed back is taken from the bottom of  $C_2$  to vertical oscillator. Vertical balancing pulses are also taken from its output and supplied to the balancing amplifier.



**Fig.4.32**

#### 4.9 POWER SUPPLY - TYPES

If the determined voltage to the TV receiver circuits in fluctuating often, the transistors, zanier diodes, capacitors, Lot and ICs would be turned defective. To avoid this, a regulated power supply is must for TV receivers.

## TYPES OF REGULATED POWER SUPPLY

There are four types of regulated power supply viz.,

1. SCR type
2. STR type
3. Transistor type
4. Switched Mode Power supply (SMPS)

Let us study about transistor type regulated power supply.

### SERIES TRANSISTOR REGULATED POWER SUPPLY

The figure shows the series transistor regulated power supply. It operates on the principle of negative feedback.

#### CONSTRUCTION

This circuit is designed with two transistors ( $Q_1$  and  $Q_2$ ) and a zener diode. Zener diode is connected at the emitter of transistor  $Q_1$ . The collector of  $Q_2$  is connected to the base of  $Q_1$ . Unregulated dc voltage is applied to the collector of  $Q_1$ . Regulated dc voltage is taken from emitter of  $Q_1$ .

#### CIRCUIT OPERATION

Unregulated dc voltage is given as input to the circuit. Even though fluctuations in the input, the output voltage is maintained constant. If input voltage increases, output voltage also increases. Due to this, collector current of  $Q_2$  increases. The rising current develops a voltage drop across  $R_3$ . So, the base voltage  $Q_1$  decreases. As a result, the output voltage also decreases. Hence the output voltage is stable.

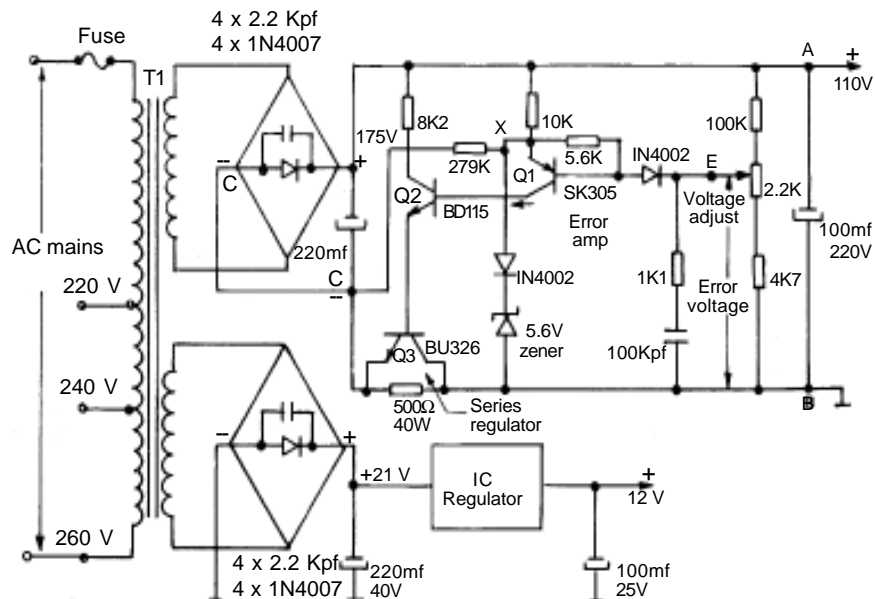

Fig.4.33

If input voltage decreases, output voltage also decreases. Due to this, the base emitter voltage decreases. As a result, collector current of  $Q_2$  decreases. The decreasing current reduces the voltage drop across  $R_3$  causes the base voltage of  $Q_1$  to increase. As a result, output voltage increases. Hence the output voltage is stable.



A supply of +110 V is taken as the output. A resistor of 10KΩ is connected in series with 110 V supply and it is earthed through a 12 V zener diode. From here, supply voltage is taken from far audio and horizontal oscillator stages. 120V zener diode acts as over voltage protector. C<sub>1</sub> and C<sub>2</sub> act as reservoir capacitors. Preset R<sup>1</sup> helps to adjust B<sup>+</sup> voltage.

## 4.11 ALIGNMENT, FAULTS AND RECTIFICATION TECHNIQUES

### II.2 ALIGNMENT OF TV RECEIVERS

The following equipments are used to align and service a TV receiver

- 1) Multimeter (20,000 Ω/V AC & DC)
- 2) Video Pattern Generator
- 3) Cathode Ray Oscilloscope (CRO)
- 4) Sweep generator or Wobbulator
- 5) Marker generator
- 6) Wobbuloscope
- 7) Vectorscope

#### MULTIMETER

We should use a multimeter with high sensitivity to align a TV Receiver. Its sensitivity should be 20,000Ω/V AC & DC. i.e. to measure  $V_{ac}$  or  $V_{dc}$ , the input impedance of the meter should be 20,000Ω. Due to the high impedance of meter, it does not create voltage drop in TV circuits while measuring. A low input impedance meter may damage ICs while measuring pin voltages.

#### EHT VOLTMETER

It is used to measure EHT voltage, which is applied to final anode of CRT of a TV receiver. It ranges from 0 to 30,000 V AC/DC. We should use heavily insulated probes to measure EHT voltage. These probes are called as EHT probes. A very high resistance is connected in series with the probes to measure this voltage.

#### VIDEO PATTERN GENERATOR

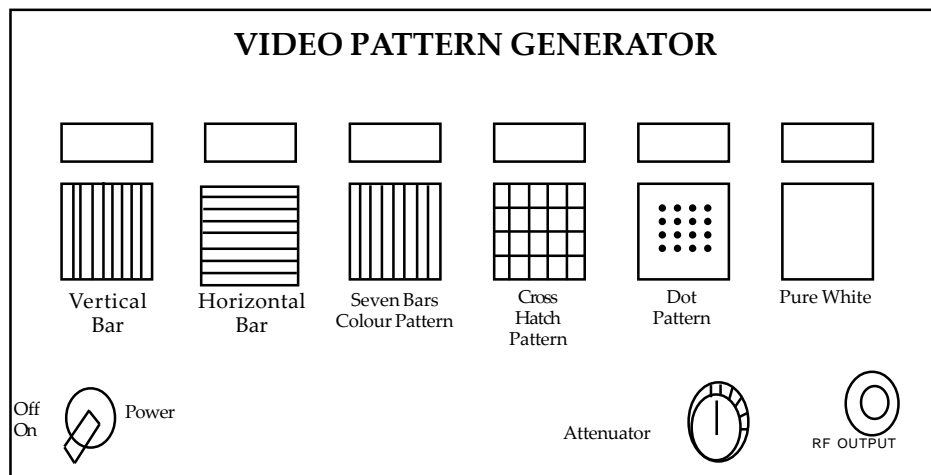

**Fig.4.34**

It is widely used to align and service TV receivers. For that purpose, it produces many patterns and sound.

## **USES**

- 1) Used to align vertical linearity, horizontal linearity and vertical height.
- 2) Used to adjust centenary of picture, pin cushion adjustment and linear aspect ratio.
- 3) Used to get perfect contrast, brightness and focusing levels.
- 4) Used to align RF, IF and sound sections.
- 5) Used to get natural colour and to adjust purity and convergence in colour receivers.
- 6) Used to align a TV receiver when the program transmission is absent.

## **FRONT PANEL LAYOUT OF A VIDEO PATTERN GENERATOR AND METHOD OF USING IT**

First, output is taken from RF out and is connected to the TV receiver. Attenuator is provided to control the gain of the RF signal.

- 1) We can adjust vertical size and linearity using horizontal bar pattern.
- 2) We can adjust horizontal linearity using vertical bar pattern.
- 3) By using cross hatch pattern, we can adjust both horizontal and vertical adjustments and also focusing.
- 4) Using 7 bar colour pattern, we can align the colour stages of a colour TV receiver to get better colour.
- 5) In colour receivers, we can align convergence adjustment using Dot pattern.
- 6) In colour receivers, we can adjust black level and white level using pure white pattern.
- 7) Using the sound from the generator, we can align sound section

## **CATHODE RAY OSCILLOSCOPE**

It is shortly named as CRO. Using this equipment, we can see the wave forms in the screen.

### **USES OF CRO**

- 1) Used to see the time varying signals
- 2) Used to align RF, IF, Deflection and sound sections of a TV receiver.
- 3) Used to measure signal voltage
- 4) Used to service TV receivers
- 5) Used to service VCR and VCP
- 6) Used to measure frequency of a signal
- 7) Used to measure phase shift

### **SWEEP GENERATOR**

It produces sweep frequency to align RF, IF and sound sections to get response curve in CRO.

### **MARKER GENERATOR**

It is used to get peak response of a particular frequency in TV receivers.

### **WOBBULOSCOPE**

It is an equipment which contains a Wobbulator, CRO and a marker generator.

### **VECTORSCOPE**

It contains a colour bar generator and a CRQ .

## ALIGNMENT PROCEDURE

1. First of all, trap circuits should be aligned.
2. If stage should be aligned next.
3. Sound section should be aligned.
4. Tuner should be aligned.

## PRECAUTIONS TO BE TAKEN BEFORE ALIGNING A TV RECEIVER

- 1) CRO, Sweep generator and TV receiver are connected through shielded cables.
- 2) All equipments should be earthed properly.
- 3) Non-magnetic screw devices should be used to align the receivers.

## VIDEO IF ALIGNMENT PROCEDURE

First of all, horizontal oscillator, AGC stages should be dialed. Connections are made as shown in the figure. The receiver and equipments should be tuned 'ON'.

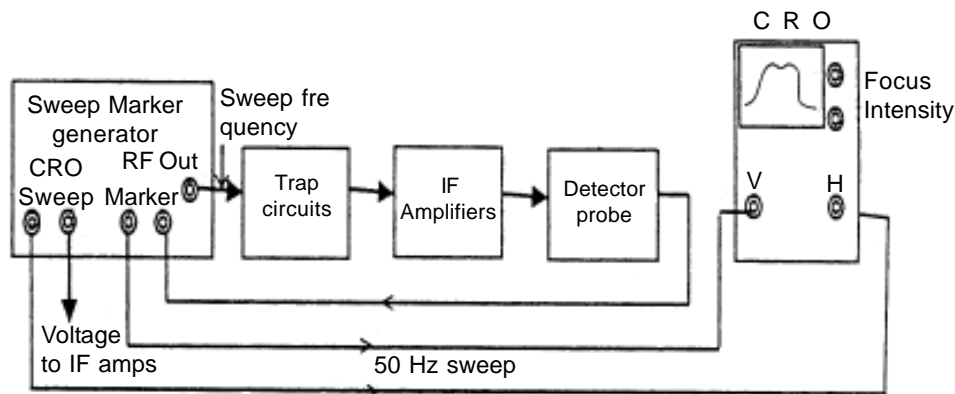

Fig.4.34

- 1) Response curve shown in the CRO screen should be made clear.
- 2) Trap circuits should be aligned in the particular frequencies to obtain accurate response curve.
- 3) Frequency range of 34 to 38MHz should be flat in the response curve. For each frequency, marker frequency should be altered and then aligned.
- 4) Alignment should be made to get 50% amplitude of 38.9 MHz

## SOUND IF ALIGNMENT PROCEDURE

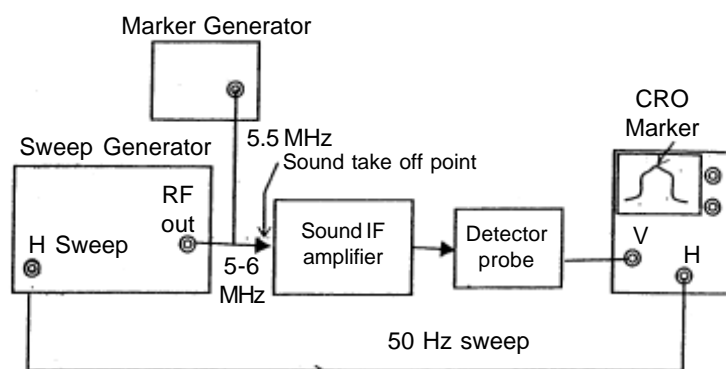

Fig.4.35

- 1) Connections should be made as shown in figure.
- 2) Tuner should be selected to a blank channel.
- 3) Marker frequency should be 5.5MHz.
- 4) 5.5 MHz frequency response should be made maximum by adjusting sound trap and sound IFTs.

### **OBTAINING BETTER ASPECT RATIO, PIN CUSHION AND CENTERING ADJUSTMENTS CENTERING**

- 1) Cross hatch pattern should be selected in the pattern generator.
- 2) Adjust the centering magnet to get the picture at the center of the screen.

### **OBTAINING BETTER ASPECT RATIO**

- 1) Adjust horizontal linearity control to get horizontal linear pattern
- Adjust vertical height, linearity preset to get vertical linearity and correct height in the pattern.

### **PIN-CUSHION ADJUSTMENT**

Adjust pin-cushion and ring magnets to get bend less pattern

## **11.2 SERVICING OF TELEVISION RECEIVERS**

The procedure of rectifying a defective receiver is called as servicing. It contains two methods.

1. Locating the fault
2. Troubleshooting

### **LOCATING THE FAULT**

The method of identifying the effective stage in receiver is called as 'Locating the fault'. We can identify it by observing symptoms in the TV receiver.

### **TROUBLE SHOOTING**

The method of identification of defective components and replacing them to operate a TV receiver in good condition as 'Trouble shooting'.

### **THE REASONS FOR A TV RECEIVER BECOMING DEFECTIVE**

- 1) Used for long hours continuously.
  - 2) Fluctuating supply voltage.
  - 3) Using in hot places
  - 4) Using in highly vibrating places(e.g. in buses)
  - 5) Accumulated dust in the receiver
  - 6) Loose contact in house wiring
  - 7) Holes in the back cover of the receiver is closed with clothes, polythene cover disabling heat dissipation
  - 8) Not disconnecting the cable and power cord when lightning occurs.
  - 9) Fast changing of channels (in mechanical tunes only)
  - 10) Water poured through the holes in the back cover
  - 11) Weak components due to ageing.
- The above reasons make a TV receiver defective

## **LET US KNOW HOW TO MAINTAIN A TV RECEIVER**

- 1) Using stabilizer to protect from voltage fluctuations
- 2) Should not be highly vibrated
- 3) Dust should be removed frequently
- 4) Loose connections in house wiring should be rectified
- 5) Do not close the back cover with clothes, polythene cover while in operation
- 6) Cable and power card should be disconnected when lightning occurs.
- 7) Protecting from not pouring of water into back side.

However maintaining a TV receiver, we cannot completely eliminate the defects occurred in it. Let us know how to find out the defective stages and components by observing symptoms in the defective TV receiver. Before that let us, study the precautions to be taken while servicing a receiver.

### **PRECAUTIONS TO BE TAKEN WHILE SERVICING**

- 1) While static test (checking of components while TV is in off position) carried over, power card and cable should be disconnected
- 2) Before static test, high voltage filter capacitors should be discharged
- 3) During dynamic test (measurement of voltage, current in a receiver) we should sit on a wooden chair to avoid electric shock
- 4) We should not touch the Lot and final anode with hands or test probes of a millimeter (even though we sit in a wooden chair) to avoid heavy shock
- 5) Do not discharge the high voltage capacitors while in operation. If it is done, it would result a heavy burst and also the receiver would become defective.
- 6) Picture tube should be handled with care. If picture tube would be fragile, implosion takes place. It may wound the nearby persons
- 7) Do not solder while receiver is functioning
- 8) Adjust  $B^+$  preset with care. Wrong adjustment may result a high  $B^+$ . It damages power transistors, LOT, ICs and picture tube in few seconds
- 9) While replacing the defective components with the new one, confirm whether it is a good quality or riot..
- 10) Do not short circuit the near by circuit components while measuring with the help of a multimeter.
- 11) If IC is used, measure pin voltages to find out the fault. Check the related components in which the pin voltage is not obtained properly as per the circuit diagram. If those components are defective, they should be replaced at once. If required, finally IC should be replaced.

### **DEFECTS OCCURRED IN TELEVISION RECEIVER**

Various defects that may occur in various stages of a television receiver are given below.

#### **DEFECTS IN ANTENNA STAGE AND TUNER**

1. Snow only; Noise only
2. Snowy picture; Noisy sound
3. Mismatching of audio and video
4. Venetian lines

5. Ghost image
6. Only few channels received

### **DEFECTS IN VIDEO IF STAGE**

1. Snow only; Noise only
2. Snowy picture; Noisy sound
3. Only Plain raster; No Program sound
4. Negative picture

### **DEFECTS IN AGC STAGE**

1. Snow only; Noise only
2. Snowy picture; Noisy sound
3. Mismatching of audio and video
4. Overloading
5. Negative picture
6. Only Plain raster; No Program sound

### **DEFECTS IN VIDEO AMPLIFIER**

1. Dark picture; Sound OK
2. No raster (light) on the screen; Sound OK
3. Retrace lines only; Sound OK
4. Picture with retrace lines; Sound OK
5. Poor contrast or dim picture
6. Smearred picture

### **DEFECTS IN PICTURE TUBE CIRCUIT**

1. Dark picture; Sound OK
2. No raster (light) on the screen; Sound OK
3. Out of focus
4. Poor contrast or dim picture
5. Retrace lines only; Sound OK
6. Picture with retrace lines; Sound OK
7. Silvery picture
8. Switch off spot

### **DEFECTS IN HORIZONTAL SWEEP SECTION**

1. Horizontal Sync. Loss
2. Dead Fault
3. Horizontally nonlinear picture
4. Vertical line only
5. Horizontal keystone
6. Blooming of picture
7. Breathing effect
8. Horizontal Fold over
9. Width less

10. Ringing
11. Mirror image

### **DEFECTS IN VERTICAL SWEEP SECTION**

1. Horizontal line only
2. Cinemascope picture
3. Vertical Sync. Loss
4. Vertically nonlinear picture
5. Vertical keystone effect
6. Vertical Jitter
7. Picture upside down

### **DEFECTS DUE TO MAGNETS USED IN YOKE SECTION**

1. Picture is not in centre
2. Pincushion effect
3. Barrel shaped raster
4. Neck shadow
5. Tilted picture
6. A bright spot only, at the centre of the screen
7. Bend in the picture at the corners of the screen

### **DEFECT IN THE SYNC. SEPARATOR STAGE**

1. Total Sync. Loss

### **DEFECT IN THE DIFFERENTIATOR CIRCUIT**

1. Horizontal Sync. Loss

### **DEFECTS IN THE INTEGRATOR CIRCUIT**

1. Vertical Sync, loss
2. Vertical jitter

### **DEFECTS IN THE POWER SUPPLY**

1. Dead fault
2. Shrunken raster
3. Hum bars and Hum in sound
4. Wavy picture
5. Picture rolling and wavy
6. Width less picture

### **DEFECTS IN THE SOUND SECTION**

1. No sound; Picture OK
2. Sound bars in picture
3. Low volume
4. Distorted Audio
5. Hum in sound
6. Noisy audio (Buzz in sound); Picture OK

## **FAULT FINDING BY OBSERVING SYMPTOMS**

We have studied about the type of defects that may have occurred in observing symptoms in the receiver: Further let us see how a fault can be found out by observing symptoms in the receiver.

### **1. DEAD FAULT**

If a TV receiver does not work completely, that is no raster and sound, this type of fault is called as Dead fault.

### **PRECAUTIONS TO BE TAKEN WHILE SERVICING A DEAD RECEIVER**

1. First of all isolate the power supply from other sections and check the power supply.
2. Discharge the high voltage capacitors.
3. If fuse is blown, check for short circuit and then only replace the fuse and operate the receiver.
4. The newly replaced fuse should be the same Ampere rating as that of the blown fuse.
5. If power supply is OK, Check the components in horizontal output, driver and oscillator in this order.

### **THE PROBABLE CAUSES FOR DEAD FAULT**

#### ***If there is no output from power supply...***

1. Defective power cord, on off switch
2. Defective AC fuse, diodes, main filter capacitor
3. Defective regulator transistor, their biasing resistors and zener diode
4. If regulator IC is used, measure the poi voltages. If it is not obtained properly, check the related components.
5. Dry Soldering; Copper print cut
6. Finally replace the regulator I. C, if required.

**Note:** We cannot conclude whether I.C. is defective or not by using a millimeter. It can be rectified only by replacement.

#### ***If Power Supply output is low ...***

7. Weak filter capacitors in 110V and. 12 V
8. Improper adjustment supply preset.

#### ***If power supply output is high ...***

9. Improper adjustment of B + supply preset
10. Defective regulator transistors, resistors, Capacitors and Zener diode

If power supply output voltage is perfect, connect it with the other stages and measure the power supply output voltages.

#### ***If the output voltages are not dropped and also the receiver is still dead. . .***

11. Horizontal output transistor, biasing resistors, driver and oscillator stages and related components may get opened.

#### ***If the output voltages are dropped after connecting with the other stages...***

12. Shorted horizontal output transistor, damper diode, fly back capacitor and partial shorted horizontal deflection coil, L.O.T. and TV 20.

**(Note :** TV 20, L.O.T. and deflection coil are mostly partially shorted. We cannot identify it accurately by using a millimeter. We can troubleshoot by replacement only).

13. Defective horizontal driver transistor, transformer, biasing resistor and other capacitors.



14. Defective oscillator transistor, biasing resistors, capacitors, H.Hold preset (or H.H Q<sub>1</sub>old coil)

(Note : If Horizontal oscillator does not produce 15,625Hz, the horizontal driver and output amplifiers also do not function. As a result, the receiver would become dead)

15. If IC is used in oscillator stage, check the pin voltages.

16. Dry soldering copper print cut

17. Finally replace the horizontal oscillator IC, if required.

## 2. SHRUNKEN PICTURE OR RASTER

If the height and width of the picture appear unusually low, it is called as shrunken picture or stamp type raster. This type of defect appears mostly in portable receivers.

It occurs due to low household AC supply or low output from the regulated power supply. First to all check, by using a voltage stabatzer.

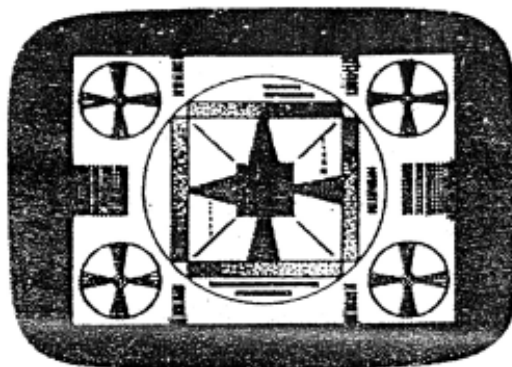

Fig.4.36

### REASONS

1. Defective regulator transistors, biasing resistors, capacitors, and Zener diode.
2. Improper adjustment of B+ preset.
3. Dry soldering; copper print cut.

## 3. HUM BARS AND HUM IN SOUND

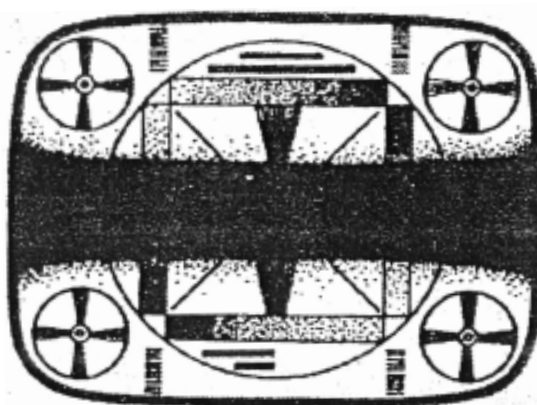

Fig.4.37

If pure d.c. is not obtained in the power supply, this fault occurs.

1. Defective rectifier diodes, filter capacitor and power transformer
2. Dry soldering; copper print cut.

#### 4. WAVY AND ROLLING OF PICTURE

If pure dc is not obtained, this fault occurs.

1. Defective rectifier diodes, filter capacitor and power transformer.
2. Dry soldering; copper print cut.

#### 5. VERTICAL LINE ONLY

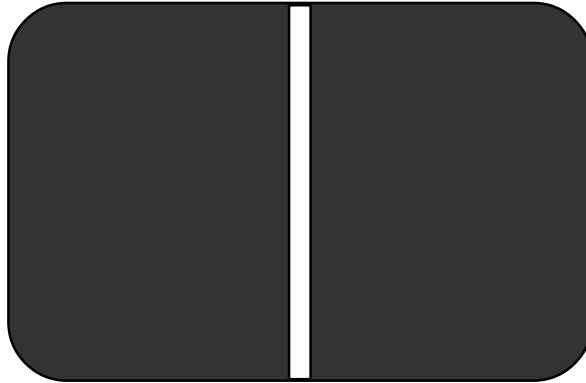

**Fig.4.38**

This defect may occur, if the components in the path of horizontal deflection coil are defective. Because, if the horizontal output, driver and oscillator stages do not function, no raster can be seen.

1. Disconnected wires to the horizontal deflection coil.
2. Open capacitor which is in series with the horizontal deflection coil.
3. Dry soldering; copper print cut
4. Open horizontal deflection coil and horizontal linearity coil (Very rare).

#### 6. HORIZONTALLY NON LINEAR PICTURE (OR) HORIZONTAL NON LINEARITY

1. Improper adjustment of horizontal linearity coil
2. Partial short in horizontal deflection coil (Very rare)
3. Defective L.O.T. (Very rare)

#### 7. HORIZONTAL FOLD OVER

1. Defective horizontal output transistor and L.O.T.
2. Using improper value of capacitor in horizontal output stage
3. Defective horizontal deflection coil



**Fig.4.39**

## 8. HORIZONTAL KEYSTONE EFFECT

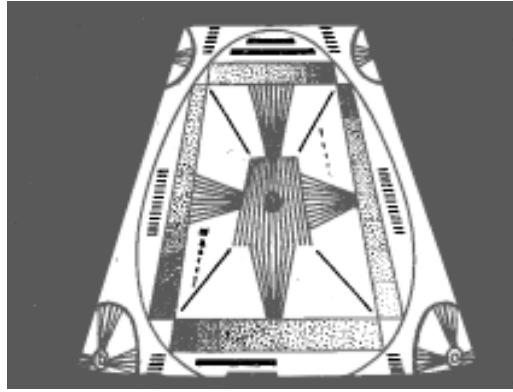
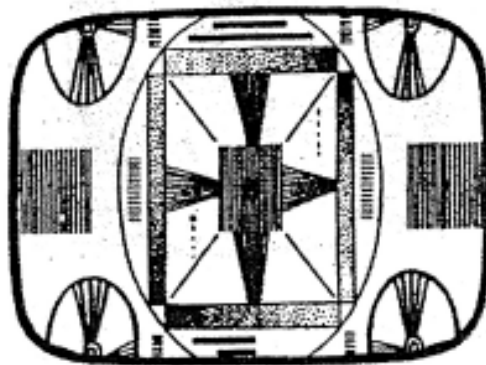

**Fig.4.40**

It is also named as horizontal trapezoidal raster.

1. Partial short in horizontal deflection coil.

## 9. BLOOMING OF PICTURE



**Fig.4.41**

If the brightness and contrast controls of a TV receiver are increased, the height and width of the picture tends to increase. If the controls are reduced, so as the height and width of the picture. This—effect is said to be Blooming of picture.

1. Defective EHT rectifier TV 20
2. Weak L.O.T.
3. Weak picture tube (Very rare)

## 10. BREATHING EFFECT

If the height and width of the picture is increased and decreased automatically, this effect is called as 'Breathing effect'.

1. Defective E.H.T. rectifier, L.O.T. and picture tube.

## 11. WINDLESS PICTURE

1. Low power supply output voltage. Weak filter capacitors
2. Defective fly back capacitor which is earthed from the collector of the horizontal output transistor.

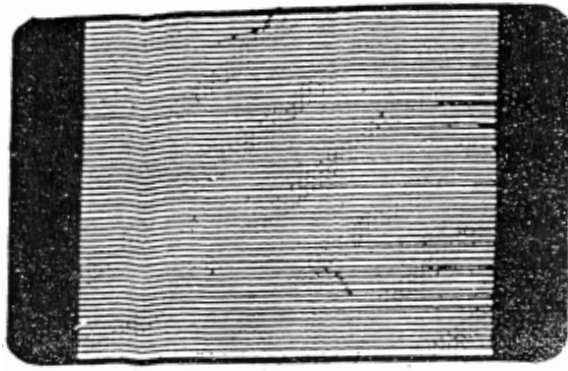

**Fig.4.42**

3. Capacitor in series with the horizontal deflection coil may be defective.
4. Partial short in horizontal deflection coil (Very rare)

## 12. RINGING

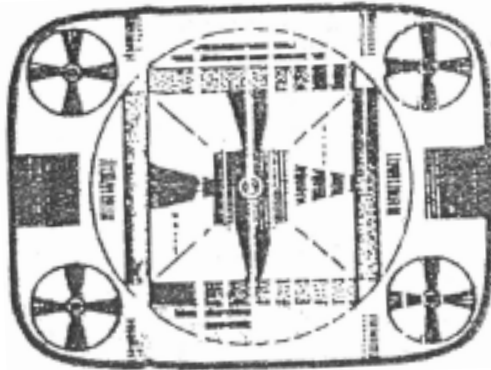
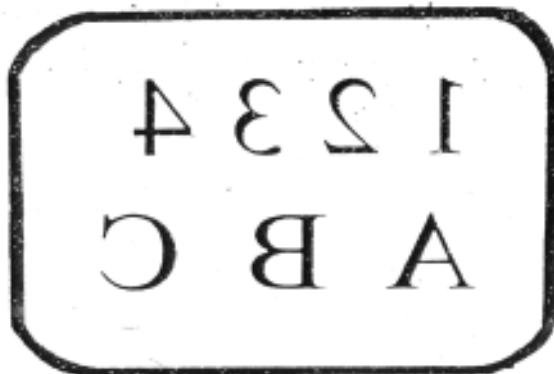

**Fig.4.43**

If vertical lines appeared in the picture, it is termed as 'Ringing'. It is also called as 'The picture is in Jail'.

1. Leaky horizontal output transistor
2. Weak L.O.T.
3. Improper value of capacitor is used for Yoke balancing !
4. Open resistor which is in parallel with the horizontal linearity coil.

## 13. MIRROR IMAGE



**Fig.4.44**

If picture is appeared as interchanging of left and right, it is called : as' Mirror image'.

1. Polarity reversed in connecting wires of horizontal deflection coil.

#### 14. HORIZONTAL SYNC. LOSS

If the picture disappeared and only black slanting lines are shown or if the picture is displaced from left to right or left to right, this effect is known as 'Horizontal Sync. Loss'  
First Adjust H.Hold.

*If the slanting lines changing its direction*, fault is in AFC stage.

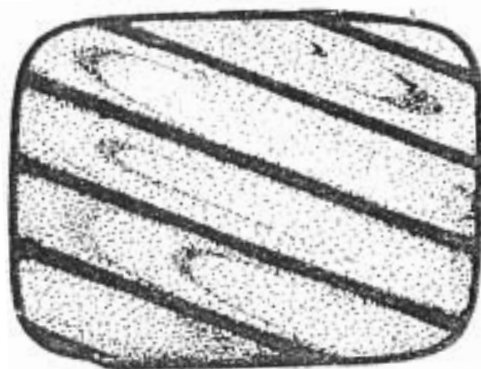

Fig.4.45

1. Defective AFC diodes
2. Check the path of fly back pulses. Dry soldering may occur.

*If the slanting lines do not change its direction* fault is in Horizontal oscillator stage.

1. Defective oscillator transistor
2. If IC is used, check the pin voltages
3. Dry soldering; copper print cut; Finally replace the IC, if required.

#### 15. HORIZONTAL LINE ONLY; SOUND OK

This is due to fault in vertical sweep section.

**(Note :** Do not operate the TV receiver with this fault continuously because, it results in permanent black line in the picture tube. So, check the receiver in frequent intervals).

When we touch the vertical size preset with a screw driver, *if the line oscillates up and down or tends to expand...* the fault is in vertical oscillator.



Fig.4.46

1. Defective vertical oscillator transistor, V.Hold, biasing resistors<sup>^</sup> and capacitors.
2. Measure pin voltages if IC is used.
3. Dry soldering; copper print cut.

***If the line does not oscillate or expand. . . .*** Fault is in vertical driver and output stage.

4. Check the transistors, biasing resistors, capacitors-in these stages.
5. Disconnection of wires to the vertical deflection coil
6. Capacitor in series with the vertical deflection coil may get opened.
7. Dry soldering or copper print cut
8. Open vertical deflection coil (rare)

## **16. INSUFFICIENT HEIGHT; SOUND OK**

If raster does not appear to a particular extent in up and down of the screen, it is called as 'Insufficient height'. It is also termed as 'Cinemascope effect'.

Fault is in vertical output stage

1. Low B<sup>+</sup> supply to vertical output stage

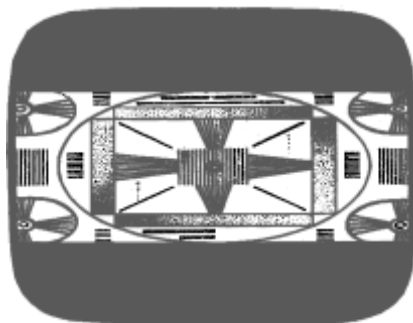

**Fig.4.47**

2. Improper adjustment of vertical size preset
3. Defective capacitor in series with the vertical deflection coil.
4. Defective vertical output transistors, biasing resistors and capacitors.
5. Dry soldering; copper print out
6. If IC is used, measure pin voltages.

## **17. VERTICALLY NON LINEAR PICTURE; SOUND OK**

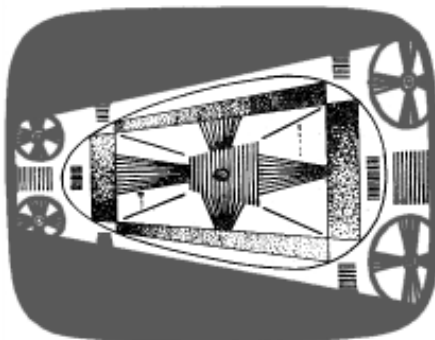

**Fig.4.48**

1. Improper adjustment of vertical linearity preset

2. Dry soldering; copper print cut
3. Defective vertical output transistors and their biasing components
4. If IC is used, measure pin voltages.
5. Finally replace the IC, if required

## 18. VERTICAL KEYSTONE EFFECT

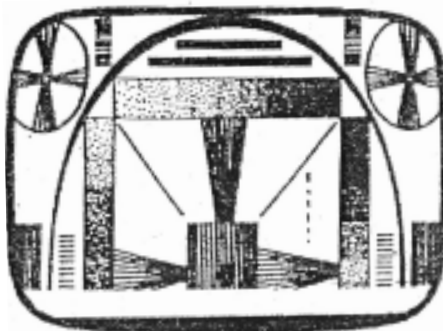

Fig.4.49

1. Partial short in vertical deflection coil

## 19. VERTICAL JITTER; SOUND OK

If picture jumps up and down, this effect is known as Vertical jitter.

1. Improper adjustment of V.Hold
2. Defective components in Integrator stage
3. Dry soldering; copper print cut.

## 19 (A). PICTURE UPSIDE DOWN ; SOUND OK

1. Polarity reversed in connecting wires of vertical deflection coil.



Fig.4.50

## 20. PICTURE ROLLING FROM TOP TO BOTTOM OR BOTTOM TO TOP SOUND OK

This effect is also known as vertical sync. loss. First of all, adjust vertical Hold.

***If rolling of picture changes its direction ....***

Fault is in Integrator stage.

1. Defective capacitor or resistor in Integrator stage. .
2. Integrator stage may not receive the sync, pulses from the sync, separator.

***If rolling of picture does not change its direction ...***

Fault is in vertical oscillator.

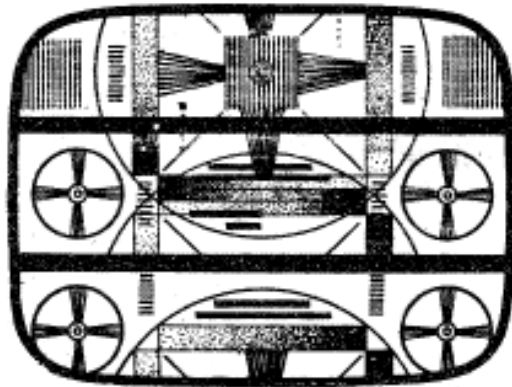

**Fig.4.51**

1. Check the vertical oscillator transistor, its biasing resistors and JV.Hold
2. If IC is used, measure pin voltages
3. Dry soldering; copper print cut
4. Finally replace the I.C, if required.

**21. PICTURE IS NOT IN CENTRE; SOUND OK**

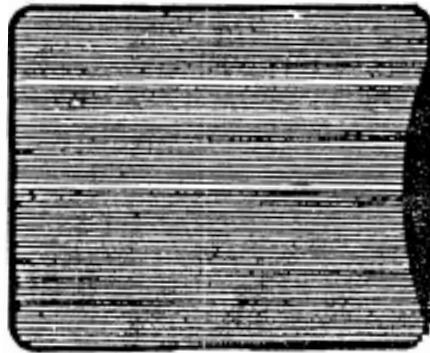

**Fig.4.52**

Improper adjustments of centering magnets. Place a mirror in front of the TV receiver. Adjust centering magnets in the yoke section properly to get correct centering of picture.

**22. PINCUSHION EFFECT**

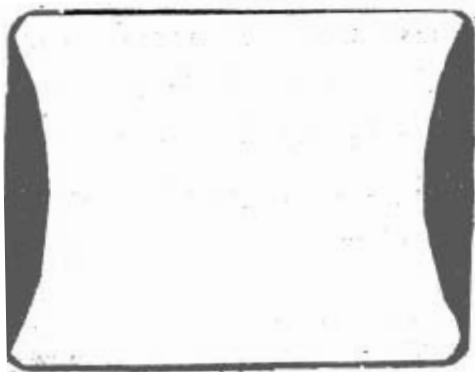

**Fig.4.53**

Improper adjustment of pincushion magnets. Place a mirror in front of the TV receiver. Adjust pincushion magnets in the yoke section properly to trouble shoot the effect.



### **23. BARREL SHAPED PICTURE**

Improper adjustment of pincushion and ring magnets.

Place a mirror in front of the receiver. Adjust properly the pincushion and ring magnets to rectify this effect.

### **24. NECK SHADOW**

If picture appears in round shape, it is known as 'neck shadow' if the yoke in the neck of picture tube moves backwards towards CRT board, this fault appears in the screen.

Place a mirror in front of the receiver.

Move the yoke towards the neck of the picture tube and tight the screw in the yoke.

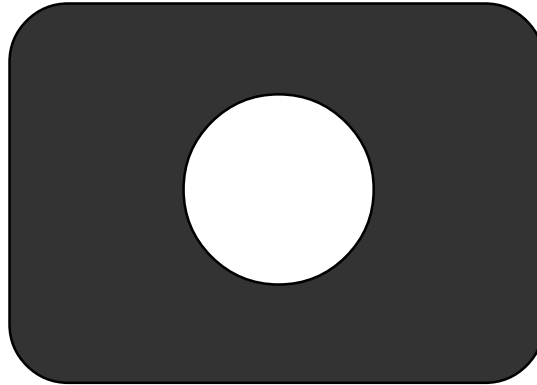

**Fig.4.54**

### **25. TILTED PICTURE**

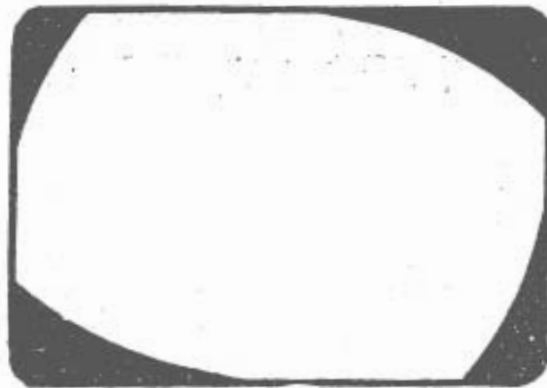

**Fig.4.55**

If yoke is tilted narrowly in the neck of the picture tube, this effect appears in the screen.

Make it to be fitted correctly and tight the screw in the yoke.

### **26. PICTURE BEND IN CORNERS**

Improper adjustment of corner correction magnets. Adjust the corner correction magnets so as to rectify it.

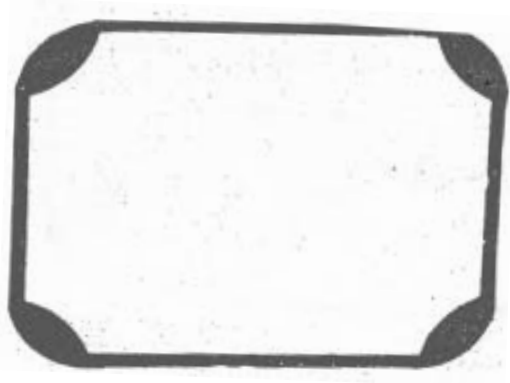
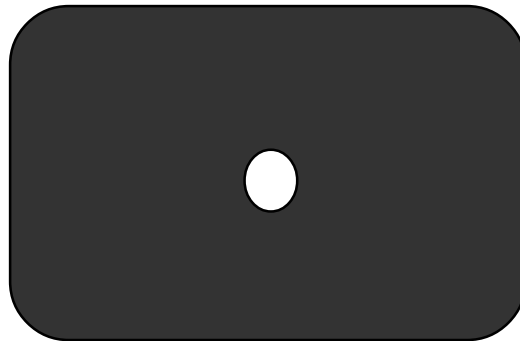

**Fig.4.56**

### **27. A BRIGHT SPOT IN THE CENTRE OF THE SCREEN**

It is also known as switch on spot. Generally, the wires connecting horizontal and vertical deflection coils may be disconnected.

Observing the wires correctly and then connect them to the respective deflection coils.



**Fig.4.57**

### **28. TOTAL SYNC. LOSS**

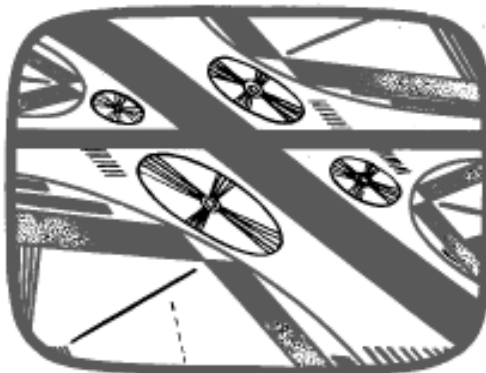

**Fig.4.58**

If picture rolls both left to right and top to bottom, it is known as 'total sync. loss'

Fault is in sync, pulse separator circuit. Check the copper track of the composite video signal to the sync, separator circuit. Check the transistor, biasing resistors and if found defective, replace it.

Resolver the dry joints.

## **29. NO RASTER (OR) NO LIGHT ON THE SCREEN; SOUND OK**

First, observe that the filament is glowing or not.

*If it glows .....*

1. Check the voltage at G1 and G2
2. Defective video output transistor and its biasing resistors
3. Absence of supply volt to the cathode
4. CRT base is not properly fitted to the picture tube.
5. Defective EHT rectifier TV 20

*If filament does not glow..... (Provided the voltages at other electrodes are OK)*

6. Check the Voltage 6.3 V AC at the filament
7. Check the continuity of the filament.

## **30. INSUFFICIENT BRIGHTNESS (OR) DARK PICTURE**

1. Low voltages at G1 and G2
2. Defective brightness Control
3. Improper fitting of CRT base
4. Defective Video output transistor and its biasing resistors
5. Dry soldering; copper print cut.

## **31. POOR CONTRAST OR DIM PICTURE ; BUT THERE IS SUFFICIENT BRIGHTNESS**

1. Defective video amplifier transistor, its biasing components and contrast control.
2. Misaligned VIF stage
3. Dry soldering; copper print cut.

## **32. DIM PICTURE; INSUFFICIENT BRIGHTNESS**

Defective picture tube.

## **33. OUT OF FOCUS OR DEFOCUS**



**Fig.4.59**

1. Low or high voltage at G3
2. Defective CRT

## **34. ARCING IN PICTURE TUBE**

First of all, switch off the TV receiver. Isolate the power supply and check the voltage at the power supply output is high or not (correct voltage: 20" B AV 110V; 14" B/W 10.4V) at the output of power supply. Find out the reasons and it should be rectified first.

Even after that, arcing takes place, the picture tube is defective. Replace it with a good one.

### **35. SILVERY PICTURE**

If silver coating like picture appears on the high white levels of the picture, it is known as silvery picture.

1. Weak picture tube
2. It may be reduced with the help of picture tube rejuvenator circuit.
3. Replacing the new one is the permanent resolution.

### **36. SMEARED PICTURE**

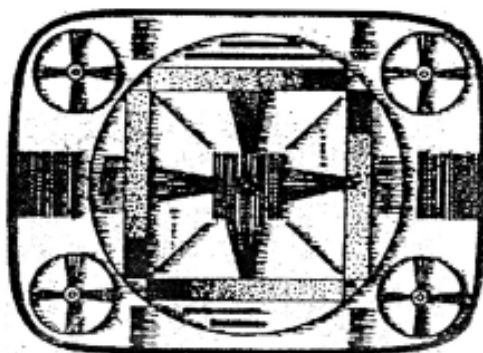

**Fig.4.60**

Very small lines appeared adjacent to the picture is known as Smeared picture. It is due to excessive low frequency response.

1. Defective peaking coil.
2. Misaligned VTF stage.

### **37. RETRACE LINES ONLY; SOUND OK**

1. Defective video output transistor and its biasing components.
2. Excessive voltage to G<sub>1</sub> and G<sub>2</sub> of picture tube (Using low value of supply resistors inappropriate)
3. Short circuited filament and calliope of the cathode of the picture tube (rare). If short circuit occurs, rectify it with the help of short removal circuit.

### **38. PICTURE WITH RETRACE LINES; SOUND OK**



**Fig.4.61**

1. Defective video output transistor and its biasing components
2. Slightly high voltage to G1 and G2
3. Check blanking amplifier, its biasing components and track of the blanking pulses to the video amplifier.
4. Weak picture tube, (rare)

### **38 A) SWITCH OFF SPOT**

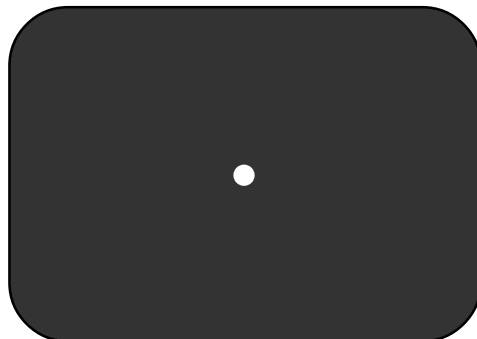

**Fig.4.62**

A bright spot appears even after the TV receiver is being switched off is called as switch off spot. If it persists for a long time, the phosphor bums and as a result a black spot appears in the centre of the screen permanently.

1. Open capacitor earthed from G1
2. Open spot killer diode.
3. Loose contact in CRT base.

### **39 A) SNOW ONLY ; NOISE ONLY (PICTURE AND SOUND HAVE NOT BEEN RECEIVED)**

For the above said symptoms, follow the instructions given below to rectify the defects. First of all, Check the TV receiver in a neighbor's house (if it is possible), where reception should be good.

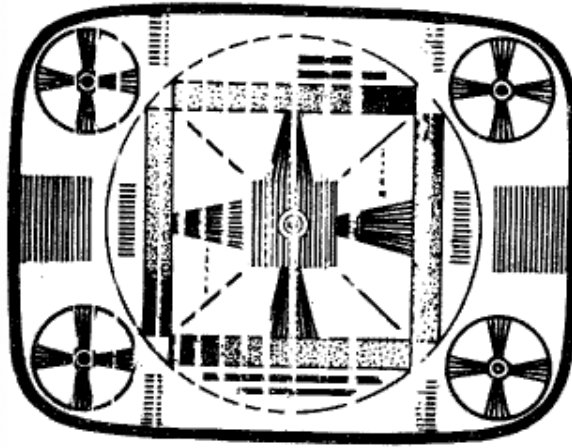

**Fig.4.63**

*At that time , the picture and sound is very good....*

Fault is in the antenna system and its related devices.

1. Incorrect antenna direction
2. Check the dipole connection, continuity of feeder wire and balun transformer.
3. Defective Booster and its power supply.



**Fig.4.64**

*If picture and sound are not received properly.*

Fault is in the TV receiver.

4. Disconnected input wires to the tuner.
5. Check the B+ and AGC voltages to the tuner.
6. Improper adjustment of AGC preset.
7. Defective RF tuner.
8. Misaligned VIF stage.
9. Dry soldering; copper track cut
10. If IC is used in the VEF stage, measure pin voltages.
11. If required, finally replace the IC

#### **40. MISMATCHING OF AUDIO AND VIDEO**

Even after fine tuning is done, the sound is received perfectly while the picture is not clear, and vice versa, this effect is called as Mismatching of audio and video.

1. Check the antenna, Booster and feeder wire
2. Improper alignment of AGC preset.
3. Defective tuner.

#### **40 A) ONLY FEW CHANNELS RECEIVED**

Defective tuner.

#### **41. GHOST IMAGE**

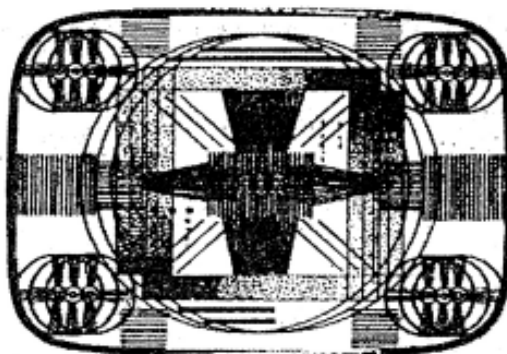

**Fig.4.65**

If an image appears very next to the picture, it is said to be Ghost image.

1. Reflected signal is the reason for this defect. Erect the antenna correctly.
2. Low quality Booster, feeder wire and tuner.

#### **42. VENETIAN LINES; SOUND OK**



**Fig.4.66**

If black and white lines appear on the picture, it is called as Venetian lines. This effect hides the picture and hence known as Venetian blind effect.

#### **REASON**

It is due to the co-channel interference. If two different TV stations being broadcast in same channel, this fault occurs in a TV receiver. Any one of the channels should be made to receive properly by adjusting the antenna system.

#### **43. ONLY PLAIN RASTER; NO PROGRAM SOUND**

If only a plain light appears without snow, it is said to be Plain raster.

#### **REASONS**

1. Unavailability of B+ and AGC voltages to the tuner.
2. Disconnected IF cable from the tuner to the VIF stage.
3. Defective tuner.
4. Defective transistors, diodes, biasing resistors, IFTs and capacitors in Video IF preamplifier, Video IF amplifier and Video detector.
5. Defective SAW filter.
6. If iC is used, measure pin voltages.
7. Dry soldering; copper print cut.
8. Replace the VIF IC, if required.
9. Defective video driver amplifier transistor and its biasing resistors.

#### **44. NEGATIVE PICTURE ; SOUND OK**

If black parts of picture appear white, and white parts appear black (like a negative film of still photo), this effect is called as Negative picture.

1. Polarity reversed video detector diocje.
2. Excessive AGC bias and defective capacitor in AGC section.

3. Absence of composite video signal from video amplifier to the AGC stage.
4. Unavailability of flyback pulses from LOT to the AGC stage.
5. Dry soldering; copper print cut

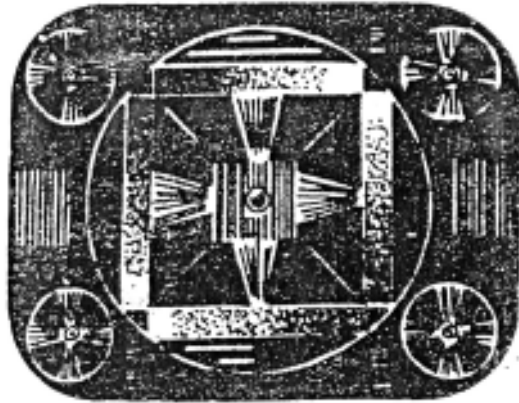

**Fig.4.67**

#### **45. OVER LOADING**

If the screen becomes dark after the antenna or cable wire is connected, this effect is known as overloading (In few TV receivers, picture wavy or pulling).

##### **REASONS**

1. Defective transistor or capacitors in AGC stage
2. If IC is used, measure pin voltages
3. Finally replace the IC, if required.

#### **46. PICTURE OK; NO SOUND**

##### **REASONS**

1. Check the speaker, its connection, and speaker coupling capacitor.
2. Check the supply voltage of the sound section.
3. Open earphone jack.
4. Defective output transistors, biasing resistors and sound IF stage.
5. Dry soldering; copper print out
6. Open volume control
7. If IC is used, measure the pin voltages.
8. Finally replace the IC, if required.

#### **47. LOW VOLUME; PICTURE OK**

1. Low B+ to the audio output stage
2. Defective speaker
3. Misaligned sound IFTs and coils
4. Defective Volume control
5. Defective capacitors
6. Dry soldering; copper print out
7. If IC is used, measure the pin voltages
8. Finally replace the IC, if required.



#### **48. DISTORTED AUDIO; PICTURE OK**

1. Defective speaker and its coupling capacitor
2. Defective audio output transistors, biasing resistors.
3. Misaligned sound IFTs and coils.
4. Dry soldering; copper print cut.
5. If IC is used, measure the pin voltages and finally replace the IC if required.

#### **49. HUM AUDIO; PICTURE OK**

1. Defective diodes and capacitors in which the supply is taken for audio section.
2. Second B+ Filter capacitor (in the sound section) may be defective.

#### **50. SOUND BARS IN PICTURE**

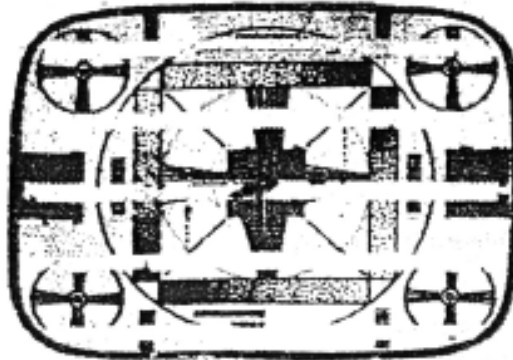

**Fig.4.68**

If bar appears while sound heard, this effect is known as sound bars in picture.  
Improper adjustment of sound trap, IFTs and Coils.

#### **51. NOISY 51. NOISY AUDIO (BUZZ IN SOUND); PICTURE OK.**

Improper adjustment of sound trap, IFTs and coils.

#### **PRECAUTIONS TO BE TAKEN WHILE HANDLING THE PICTURE TUBE**

1. The neck of the picture tube is made of thin glass. Do not over tight the screw in the yoke.
2. The pins of the CRT may get broken while fixing and removing CRT board. So, handle with care.
3. A shield wire should be placed over the aquatic coating of the picture tube and it should be earthed. Otherwise it will give shock to us.
4. Before disconnecting the final anode point, it should be discharged first with heavily insulated screw drives.
5. Since picture tube is evacuated, if mishandled, it may get implosion and as a result the tube fragments may fly in all directions and may cause sever injury to the nearby persons. So, it should be handled with care.

Let us know the defects arising in the picture tube and how to replace the old picture tube with a new one.

#### **DEFECTS**

1. Insufficient brightness ever after the brightness control is at maximum.

2. Insufficient black level even after the contrast control is at maximum.
3. Dim light appears due to weak cathode emission.
4. Blue arcing in the picture tube.
5. No light because of opened filament.

The New picture tube to be bought should be the same model as that of the old one. Care should be taken while checking the biasing voltage of old CRT, which should be suitable to the new CRT. If not, we should arrange for the biasing voltages to the new CRT.

### **PROCEDURE OF FIXING A NEW PICTURE TUBE**

1. First, discharge the final anode point and then disconnect it.
2. CRT board and yoke should be removed from the old CRT.
3. Unscrew the four nuts fixed on the cabinet using tubular spanner.
4. Remove the earth wire
5. Place the new CRT and tight the four nuts on the cabinet using tubular spanner.
6. Shield wire should be tightly tied in the external aquadag coating and earthed.
7. Yoke and CRT board should be placed one by one.
8. Final anode point should be connected properly. Now if we switch on the TV receiver, sufficient brightness and contrast can be obtained in the picture.

## **QUESTIONS**

### **I. CHOOSE THE BEST ANSWER**

1. To Form picture on the television screen we need \_\_\_\_\_ scanning lines per second  
 A) 625                      B) 1025                      C) 15625                      D) 50
2. The electron ray moving from left to right and right to left is called as \_\_\_\_\_  
 A) Horizontal scanning                      B) Vertical scanning  
 C) Interlaced scanning                      D) Sequential scanning
3. The ratio of picture tube's length and height is called \_\_\_\_\_  
 A) Kell factor                      B) Interlaced scanning  
 C) Aspect Ratio                      D) Selectivity
4. The output current of the camera tube is called depend upon light falls on the glass face plate is called \_\_\_\_\_  
 A) Spectral Response                      B) Dark current  
 C) Light Transfer characteristic                      D) Sound Transfer characteristic
5. VEDIO band width in the CCIR-PALB system is \_\_\_\_\_  
 A) 10MH2                      B) 15MH2                      C) 25MH2                      D) 5MH2
6. The function of VEDIO Detector filter the carrier waves from the VEDIo IF signal and separate the \_\_\_\_\_  
 A) Composite VEDIO signals                      B) AF waves  
 C) RF waves                      D) VEDIO signals
7. The rate of Horizontal frequency in TV Receiver is \_\_\_\_\_  
 A) 625H2                      B) 75H2                      C) 15625H2                      D) 75H2
8. A saw tooth wave of \_\_\_\_\_ is needed for vertical scanning  
 A) 50H2                      B) 75H2                      C) 15 625H2                      D) 75H2



## **V.ANSWER BRIEFLY**

1. Explain the working of picture tube.
2. Draw and Explain the block diagram of TV to Transmitter.
3. Draw the block diagram of a between TV Receiver with Wave forms.
4. Draw the functions of venous stage in between TV receiver.
5. Draw and Explain the direct coupled video amplifier circuit with wave forms.
6. List out the probable causes for Dead fault in a TV receiver in Sequential order.
7. Explain the Working of image orthicon camera tube with neat diagrams.
8. Explain the working of Videocon camera tube with explain sketches.
9. Draw and explain the horizontal deflection circuit.
10. A TV Receiver shows Horizontal line only sound OK stage the Reason for it.

## **ANSWERS**

1.A 2.B 3.C 4.C 5.D 6.A 7.C 8.A 9.C 10.C

## 5. AUDIO, VIDEO EQUIPMENTS

### 5.1 INTRODUCTION

#### GRAMOPHONE

Gramophone is kind of record player. The sounds which is stored in the place is convert in to an electrical note by a tone arm. It is used to hear the songs and music's, so it is called record player.

#### RECORDING TECHNIQUE

The important parts of a gramophone

1. Turn table
2. Tone arm
3. Pick up head
4. Motor
5. Speed regulator

#### 1. TURN TABLE

It is a round made by aluminum or steel which is always in rotation. It is not directly connected to the motor. There is a rubber wheel in touch with the rim of the rotating plate. The diameter of the wheel is less than the rotating disc. Also the diameter of the motor axis is small. A number of rotation in the axis make one rotation in the wheel and a number of rotation in the wheel make one rotation in the disc. Thus the rotation transfers from motor to disc. So any high speed in the motor rotation, gives only a slow rotation in the disc recording plates are placed on the disc.

#### 2. TONE ARM

Tone arm is a handle part which have a touch with player. It has a pick up head on cartridge. Using the tone arm the recorded songs are convert in to electrical waves by making a friction with the player. This electrical wave are given to the input of the amplifier. There is a spring which is used move the needle uniformly. So the tone arm move smoothly on the record player even though has many up and downs.

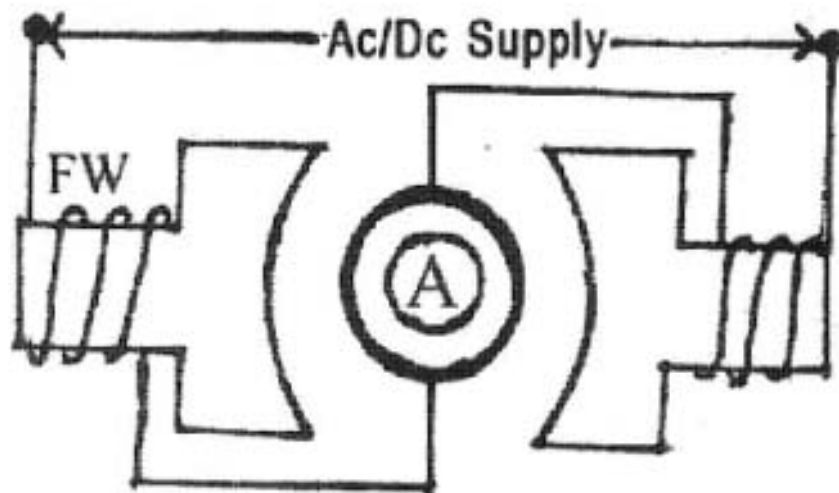

F.W.Field winding  
A-Armature

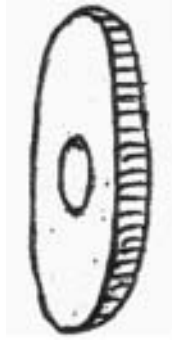

**Regulator knob**

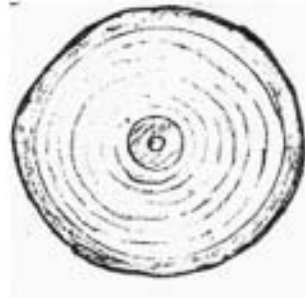

**Record player**

**Tone arm**

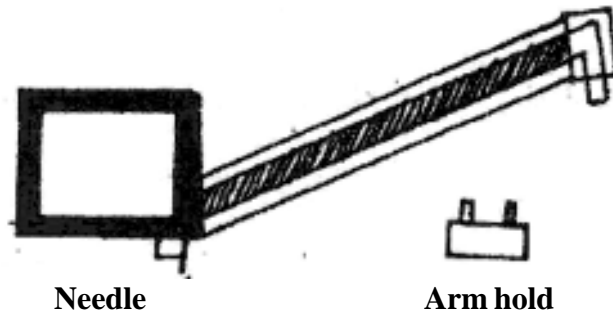

**Turn Table**

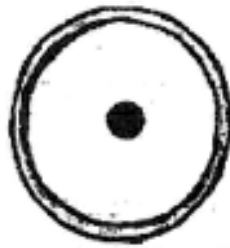

**Pick up Head (Crystal)**

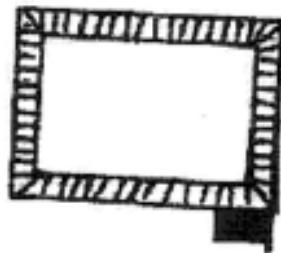

**Micro phone**

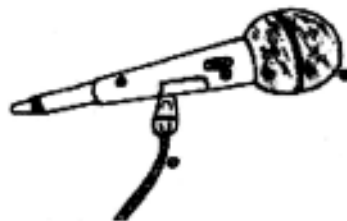

**Fig. 5.1 (a) parts of a gramophone**

### 3. CRYSTAL (Pickup head)

It is in the tip of the tone arm. The crystal is used to convert the sound into electrical wave.

### 4. MOTOR

It is a blower or universal motor has particular speed with low voltage. Some players have d.c.motors

### 5. SPEED REGULATOR

Speed regulators controls the speed of the player. It is also used the change the speed in the range of 16RPM, 35RPM, 45RPM and 78RPM. This means if we change the switch in position 45rPM it has 45 rotation per minute.

### WORKING PRINCIPLE

Switch on the power, the player begins its rotation at once, while the player on the turn table have a certain speed to rotate. Keep the crystal point of the tone arm on the player. The line which is printed on the plate make a connection with the needle, and convert it an into a electrical wave. This waves are given to an amplifier to amplify the signal. This amplified signals are transfer to the speaker. Speaker again convert the electrical signal in to sound signal.

### 5.2 TAPE RECORDER

It is a device used to share the music in a ribbon winded in to small wheels. So it is called tape recorder. Recorded music's or songs are convert into electrical signal and stored in the ribbon (tape)

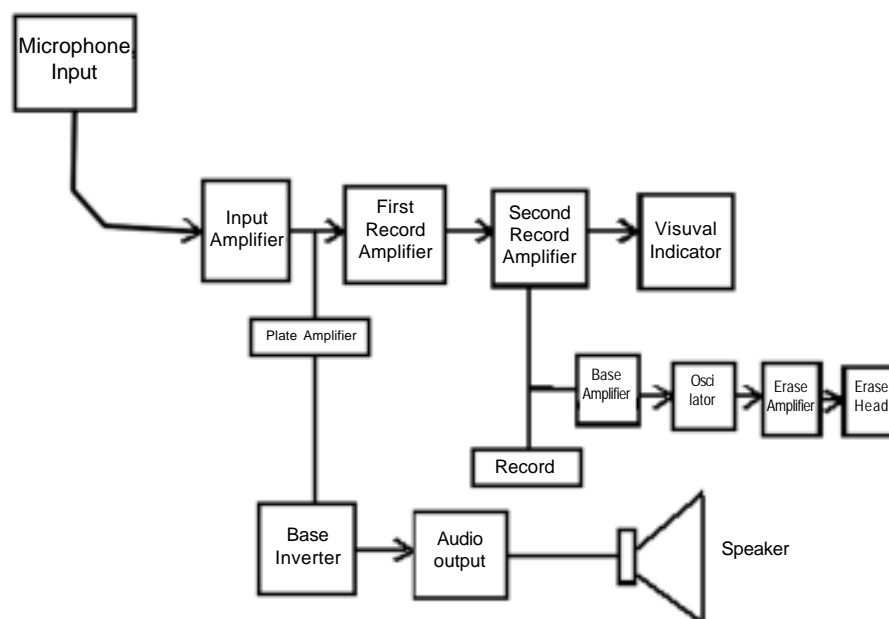

5.2 Block diagram of tape recorder

### RECORDING TECHNIQUES

The main parts of the tape recorder

1. Tape
2. Head
3. Motor

4. Amplifier
5. Micro phone
6. Loud speaker
7. Supply wire

### **1. TAPE**

It is a rectangle shaped plastic box. It contains two wheels. Along tape made by Zinc with iron which is used to record the music. Tape records are available in C-60, C-90 size of cassettes.

### **2. HEAD**

According to the speed of the tape recorder, the sound signal is changed. This change of speed is convert in to electrical signal then given onto an amplifier stage.

### **3. MOTOR**

Motor is used to drive the two wheels, which is winded with ribbons. The wheels are indirectly connected to the motor by a belt. The motor is less power shaded pole motor or synchronous motor type.

### **4. LOUD SPEAKER**

This converts the electrical signal in to sound signal

### **5. MICRO PHONE**

It is used to convert the sound signal into electrical signal

### **6. VOLUME CONTROL**

This control is used to increase or decrease the sound. It is a variable resister. A round carbon track having micro plate moving along the track. The distance between the carbon tracks varies the current. Thus the volume changed.

### **7. POWER CORD**

It supplies the voltages from the main power supply. There are three colour wires in the card are red, green and black. It means that red is +ive, black is -ve and green is ground.

### **8. AMPLIFIER**

It amplifies the weak signal into high level the amplified output is given in to the speaker.

### **KINDS OF BUTTONS IN A TAPE RECORDER**

1. Record
2. Playback
3. Re/wind (R.W)
4. Fron/Forward(F.F)
5. Stop
6. Eject
7. Auto stop

A small motor made by plastic or steel having low power speed. It is a synchronous motor or shade pole motor. A proper connection is made in front of the tape which is used to record the music.



A button switch on the tape recorder drive the tape to move. A rectifier circuit is connected to the motor which gives a DC supply voltage.

By giving the DC supply to the motor and open the cassette door using eject button and put the tape in side. Switch the head button the tap begins to move with help of motor. The head reads the tape and converts the sound signal in to electrical signal. This electrical signal is amplified by an amplifier and then given to the speaker. Speaker converts the electrical signal in to sound signal.

## APPLICATIONS

1. It is used as a home appliance
2. We can enjoy the music's using tape recorder
3. It needs only low voltage
4. Different shapes and kinds of cassettes are available in the market at low prices.

## 5.3 COMPACT DISC (CD)

A compact disc is an optical disc used to store digital data. It was originally developed to store sound recordings exclusively, but later it also allowed the preservation of other types of data. Audio CDs have been commercially available since October 1982. In 2010, they remain the standard physical storage medium for audio.

Standard CDs have a diameter of 120mm and can hold up to 80 minutes of uncompressed audio (700MB of data). The Mini CD has various diameters ranging from 60 to 80mm; they are sometimes used for CD singles or device drivers, storing up to 24 minutes of audio.

The technology was eventually adapted and expanded to encompass data storage CD-ROM, write – once audio and data storage CD-R, rewritable media CD-RW, video compact discs (VCD), super video compact discs (SVCD), photo CD, picture CD, CD-I, and enhanced CD.

A CD is made from 1.2mm thick, almost pure polycarbonate plastic and weighs 15-20grams. From the center outward, components are: the centre (spindle) hole, the first transition area (clamping ring), the clamping area (stacking ring), the second transition area (mirror band), the information (data) area, and the rim.

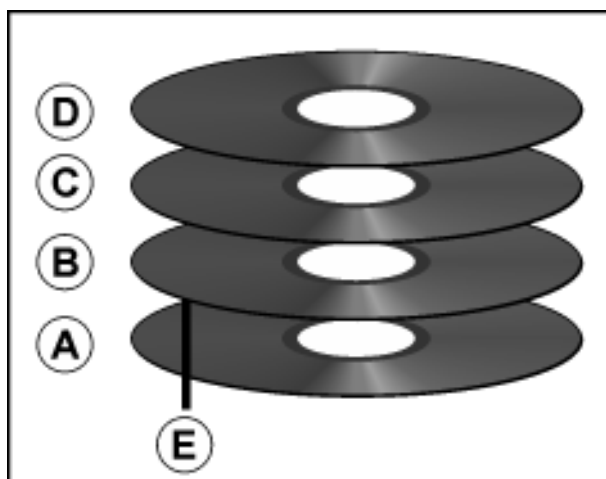

A thin layer of aluminum or, more rarely, gold is applied to the surface making it reflective. The metal is protected by a film of lacquer spin coated directly on the reflective layer. The label is printed on the lacquer layer. Common printing methods for CDS are screen printing and offset printing.

CD data are stored as a series of tiny indentations known as “pits”, enclosed in a spiral track model into the top of polycarbonate layer. The areas between pits are known as “lands”. Each pit is approximately 100nm deep by 500nm wide, and varies from 850nm to 3.5µm in length.

Diagram of CD layers. A. A Polycarbonate layer has the data encoded by using bumps. B. A shiny layer reflects the laser. C. A layer of lacquer helps keep the shiny layer shiny. D. Artwork is screen printed on the top of the disc. E. A laser beam reads the CD and is reflected back to a sensor, which converts it into electronic data.

The distance between the tracks, the pitch is 1.6µm. A CD is read by focusing a 780nm wavelength (near infrared) semiconductor laser through the bottom of the polycarbonate layer. The change in height between pits (actually ridges as seen by the laser) and lands results in a difference in intensity in the light reflected. By measuring the intensity change with a photodiode, the data can be read from the disc.

### **5.3.1 VIDEO COMPACT DISC (VCD)**

VCD stands for “video compact disc” and basically it is a CD that contains moving pictures and sound. A VCD has the capacity to hold up to 74/80 minutes on 650MB/700Mb CDS respectively of full motion video along with quality stereo sound. VCDs use a compression standard called MPEG to store the video and audio. A VCD can be played on almost all standalone DVD players and of course on all computers with a DVD-ROM or CD-ROM drive with the help of a software based decoder/player. It is also possible to use menus and chapters, similar to DVDs on a VCD and also simple photo album/slide shows with background audio. The quality of a very good VCD is about the same as a VHS tape based movie but VCD is usually a bit more blurry. If you want better quality checkout SVCD, CVD or DVD.

### **5.3.2 MP3 CD**

An MP3 is a compact disc (usually a CD-R or CD-RW) that contains digital audio in the MP3 file format.

Because of audio data compression, an MP3 CD does not have to spin all of the time, thereby saving battery power. The song is buffered in random-access memory, which also provides protection against skipping. The number of songs that a disc can hold depends on how the songs are encoded and the length of the songs. A standard audio CD (74minutes) can hold about 18 songs, a data CD containing mid-quality (160Kbps) MP3 files can hold about 138 songs.

ID3 tags stored in MP3 files can be displayed by some players, and some players can search for MP3 files within directories on an Mp3 CD. The sound quality of an MP3 CD is inferior to that of an audio CD, because MP3 compression is lossy. Because MP3 CDs are just plain data CDs with MP3 files on them, and there is no official standard, the format expected by different players varies. This sometimes leads to incompatibilities and difficulty in playing disks for various reasons such as: filename length limits, sub folder limits, number of files limits and special character bugs.

### **5.3.3 DVD**

DVD also known as digital versatile disc., is an optical disc storage media format and was invented and developed by Philips, Sony, Toshiba and Time Warner in 1995. Its main uses are video and data storage. DVDs are of the same dimensions as compact discs (CDS), but are capable of storing just under seven times as much data.

Variations of the term DVD often indicate the way data is stored on the discs: DVD-ROM (read only memory) has data that can only be read and not written; DVD-R and DVD+R (recordable) can record data only once. DVD-RW (rewritable), DVD+RW, and DVD-RAM (random access memory) can all record and erase data multiple times. The wavelength used by standard DVD lasers is 650nm; thus the light has a red colour.

DVD-Video and DVD-Audio discs refer to properly formatted and structured video and audio content, respectively. Other types of DVDs, including those with video content, may be referred to as DVD data discs.

### **5.3.4 MP4**

MP4 is an abbreviation for moving picture expert Group-4. First published in 1998, MPEG-4 or MP4 was designed to encompass all the features that were part of earlier releases of MPEG files and add a few more that would prove helpful with the advancing online technology of the day. As a standardized group of video and perceptual coding formats. MP in general quickly became a hit with the average internet user. The introduction of MP4 made it possible for the audience to continue growing by providing quicker, faster and higher quality broadcast media for the average user.

So great was the success of MP4 that by 1999, it was considered the gold standard for all types of streaming and broadcast applications online. The functionality of the format was such that programmers were able to easily make use of MP4 on web sites and in various other applications. Businesses found it to be a sales and marketing tool, and residential users also had a great time viewing, swapping, and even creating their own streaming media in the mP4 format.

Because MP4 was a reliable application that required a relatively low amount of bandwidth, just about everyone could take advantage of using the tool. This was especially true as technology made it possible to create more powerful desktop and laptop systems. The enhancement of the speed of various types of internet connections also helped to make MP4.

### **5.3.5 BLU RAY DISC**

Blu-ray disc (official abbreviation BD) is an optical disc storage medium designed to supersede the standard DVD format. Its main uses are for storing high-definition video, play station 3 video games, and other data with up to 25GB per single layered, and 50GB per dual layered disc.

The name Blu-ray disc derives from the “blue laser” used to read the disc. While a standard DVD uses a 650nanometer red laser, Blu-ray disc uses a shorter wavelength 405nm laser, and allows for over five times more data storage on single layer and over ten times on double layer Blu-ray disc than a standard DVD. The laser color is called “blue”, but is violet to the eye.

Blu-ray discs can be clustered together in systems such as optical jukeboxes to increase data storage. This increase of storage can span multiple terabytes and utilize hundreds of Blu-ray discs. These systems are currently the largest storage units using Blu-ray technology.

## **5.4 MEMORY CARD**

A memory card (sometimes called a flash memory card or a storage card) is a small storage medium used to store data such as text, pictures, audio and video, for use on small, portable devices. Most of the current products use flash memory, although other technologies are being developed. There are number of memory cards on the market, including the SD card (secure digital card), the CF card (compact flash card), the smart media card, the memory stick, and the multi Media Card (MMC). These cards are of varying sizes, and each is available in a range of storage capacities that typically corresponds directly to the price. The compact flash card is about the size of a matchbook, while the mediacard and secure digital card are each about the size of a postage stamp. The latter two are expected to reach storage capacities up to 1 gigabyte (GB) by the end of 2002.

Most available cards have constantly powered nonvolatile memory, which means that data is stable on the card, is not threatened by a loss of power source, and does not need to be periodically refreshed. Because memory cards are solid state media, they have no moving parts, and therefore, are unlikely to suffer mechanical difficulties. Earlier removable storage media, such as the PC Card, the smart card, and similar cards used for game systems can also be considered to be memory cards. However, the newer cards are smaller, require less power, have higher storage capacity, and are portable among a greater number of devices.

### **5.4.1 UNIVERSAL SERIAL BUS (USB)**

Universal Serial Bus (USB) is a specification to establish communication between devices and a host controller (usually personal computers), developed and invented by Ajay Bhatt while working for Intel. USB is intended to replace many varieties of serial and parallel ports. USB can connect computer peripherals such as mice, keyboards, digital cameras, printers, personal media players, flash drives, and external hard drives. For many of those devices, USB has become the standard connection method. USB was designed for personal computers, but it has become commonplace on other devices such as smartphones, PDAs and video game consoles, and as a power cord.

The Universal Serial Bus (USB) is a standard for peripheral devices. It began development in 1994 by a group of seven companies: Compaq, DEC, IBM, Intel, Microsoft, NEC and Nortel. USB was intended to make it fundamentally easier to connect external devices to PCs by replacing the multitude of connectors at the back of PCs, addressing the usability issues of existing interfaces, and simplifying software configuration of all devices connected to USB. The first silicon for USB was made available by Intel in 1995. The USB 1.0 specification was introduced in January 1996. The original USB 1.0 specification had a data transfer rate of 12 Mbit/s. the first widely used version of USB was 1.1.

## **5.5 IPOD – PRINCIPLES AND TECHNIQUES**

The iPod is a portable media player designed and marketed by Apple and launched on October 23, 2001, the product line-up includes the hard drive-based iPod Classic, the touchscreen iPod Touch, the video-capable iPod Nano, and the compact iPod. As with many other digital music players, iPods can also serve as external data storage devices. Storage capacity varies by model, ranging from 2 GB for the iPod Shuffle to 160 GB for the iPod Classic.

The iPod branding is also used for the media player applications included with the iPhone and iPad; the iPhone version is essentially a combination of the Music and Videos apps on the iPod Touch. Both devices can therefore function as iPods, but they are generally treated as separate products.

Unlike many other MP3 players, simply copying audio or video files to the drive with a typical file management application will not allow an iPod to properly access them. The user must use software that has been specifically designed to transfer media files to iPods, so that the files are playable and viewable.

Media files are stored on an iPod in a hidden folder, along with a database file. The hidden content can be accessed on the host operating system by enabling hidden files to be shown. The media files can then be recovered manually by copying the files or folders off the iPod. Many third party applications also allow easy copying of media files off an iPod.

## **5.6 HOME THEATER**

Until recently, the best way to watch a movie was to go to a movie theater. The introduction of VCRs made it easy to rent or buy movies and watch them at home, but TVs just didn't compare to movie theaters' huge screens and surround-sound systems. Not only did TVs have comparatively tiny screens and lower quality speakers, formatting a movie to fit the screen got rid of a substantial part of the picture.

Now, more and more people are turning their ordinary TV rooms into home theaters. This used to involve a projector and a screen, and it was too expensive for most people to afford. But advances in technology have given people more choices for home theater setups, and some people find that a home theater is quieter and more convenient than a movie theater – and the picture and sound are great.

### **WHAT IS HOME THEATER?**

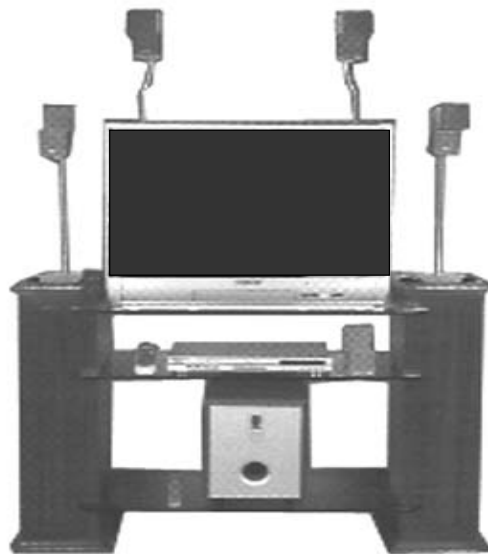

**5.6(a) A home theater consisting of a DVD player with built-in surround sound receiver and a collection of speakers**

Home theater is difficult to define – it's really just a vague term for a particular approach to home entertainment. Generally speaking, a home theater system is a combination of electronic components designed to recreate the experience of watching a movie in a theater. When you watch a movie on a

home theater system, you are more immersed in the experience than when you watch one on an ordinary television.

The basic idea of home theater is to recreate the same elements with home equipment. At the bare minimum, the following are needed

- A large-screen television (at least 27 inches across, measured diagonally) with a clear picture.
- At least four speakers
- Equipment for splitting up the surround-sound signal and sending it to the speakers.
- Something that plays or broadcasts movies in surround sound, preferably with a clear picture.
- And a room to arrange all this.

## **SURROUND SOUND BASICS**

The main thing that sets a home theater apart from an ordinary television setup is the surround sound. For a proper surround-sound system, you need two to three speakers in front of you and two to three speakers to your sides or behind you. The audio signal is split into multiple channels so that different sound information comes out of the various speakers.

The most prominent sounds come out of the front speakers. When someone or something is making noise on the left side of the screen, you hear it more from a speaker to the left of the screen. When something is happening on the right, you hear it more from a speaker to the right of the screen.

The third speaker sits in the center, just under or above the screen. This center speaker is very important because it anchors the sound coming from the left and right speakers – it plays all the dialogue and front sound effects so that they seem to be coming from the center of your television screen.

The speakers behind you fill in various sorts of background noise in the movie – dogs barking, rushing water, the sound of a plane overhead. They also work with the speakers in front of you to give the sensation of movement – a sound starts from the front and then moves behind you. These sounds get split up by the audio/video receiver, which is the real heart of a home theater.

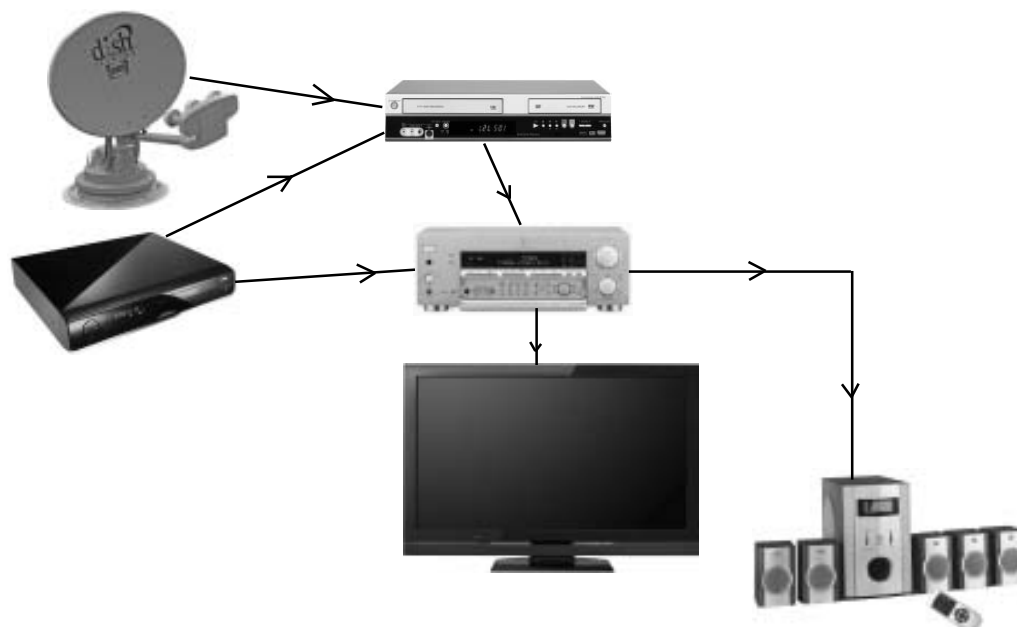

**5.6(b) The receiver heart of a typical home theater system**

### **5.6.1 DOLBY DIGITAL**

Dolby Digital is the name for data and audio compression technologies developed by Dolby Laboratories. It was originally called Dolby Stereo Digital until 1994. Dolby Digital has similar technologies, included in Dolby Digital live, Dolby Digital plus, Dolby Digital Surround EX, Dolby Digital Recording, Dolby Digital Cinema, Dolby digital Stereo Creator and Dolby Digital 5.1 Creator.

Dolby digital is the common version containing up to six discrete channels of sound. The most elaborate mode in common usage involves five channels for normal-range speakers (20Hz – 120 Hz allotted audio) for the subwoofer driven low-frequency effects.

Dolby Digital was first developed for multichannel cinema sound, adding impact and realism to the movie going experience. It quickly became essential to the movie industry, and today is a recognized standard, worldwide, in surround sound for both cinemas and home theaters. In fact, every DVD player and Blu-ray Disc™ player, nearly 60 million digital cable and satellite set-top boxes, and more than 50 million audio/video receivers are equipped with Dolby Digital technology. More video games also support Dolby Digital audio. That means you can count on enjoying Dolby Digital's rich, enveloping cinema-quality surround sound just about everywhere you go.

### **DOLBY TECHNOLOGY**

When audio is turned into digital information (a process called encoding), the data is compressed so it can be broadcast, distributed on disc, or delivered online as efficiently as possible. The data is then decoded for playback. Dolby Digital is an advanced encoding/decoding technology that faithfully reproduced sound as it was originally recorded.

### **5.6.2 DTS**

DTS is a series of multichannel audio technologies owned by DTS formerly known as Digital Theater Systems, Inc.), a company specializing in digital surround sound formats used for both commercial/theatrical and consumer grade applications. It was known as the Digital Experience until 1995.

The basic and most common version of the format is a 5.1 – channel system, similar to a Dolby Digital setup, which encodes the audio as five primary (full-range) channels plus a special LFE (low-frequency effect) channel for the subwoofer.

Other, newer DTS variants are also currently available, including versions that support up to seven primary audio channels plus one LFE channel (DTS-ES). These variants are generally based on DTS' core+extension philosophy, in which a core DTS data stream is augmented with an extension stream which includes the additional data necessary for the new variant in use. The core stream can be decoded by any DTS decoder, even if it does not understand the new variant. A decoder which does understand the new variant decodes the core stream, and then modifies it according to the instructions contained in the extension stream. This method allows backward compatibility.

In theatrical use a proprietary 24-bit time code is optically imaged onto the film. An LED reader scans the timecode data from the film and sends it to the DTS processor, using the time code to synchronize the projected image with the DTS soundtrack audio. The multi-channel DTS audio is recorded in compressed form on standard CD-ROM media at a bitrate of 1,103 kbit/s. The theatrical DTS processor acts as a transport mechanism, as it holds and reads the audio discs. When the DTS format was launched it used one or two discs with later units holding three discs, thus allowing a single

DTS processor to handle two-disc film soundtracks along with a third disc for theatrical trailers. The DTS time code on the 35mm print identifies the film title which is matched to the individual DTS CD-ROM's guaranteeing that the wrong film cannot be played with the wrong disc.

## QUESTIONS

### I. CHOOSE THE BEST ANSWER.

1. The turn table of gramophone plate is made from  
 a) Iron                      b) Copper                      c) Plastic                      d) carbon
2. Tape recorder ribbon is made up of  
 a) Iron                      b) Iron & Zinc                      c) Zinc                      d) Aluminum
3. In tape recorder which type of microphone is used  
 a) Carbon                      b) Condenser                      c) crystal                      d) Dynamic
4. A standard CD has a diameter of \_\_\_\_\_  
 a. 80mm                      b. 110mm                      c. 60mm                      d. 120mm
5. The distance between the liners in a CD is \_\_\_\_\_  
 a. 1.8 $\mu$ m                      b. 1.9 $\mu$ m                      c. 1.6 $\mu$ m                      d. 2.6 $\mu$ m
6. MP3 can store the digital sound in \_\_\_\_\_ format  
 a. Famers                      b. file                      c. index                      d. bars
7. A medium CD can store \_\_\_\_\_ Songs in a MP3 file  
 a. 138                      b. 18                      c. 500                      d. 100
8. In DVD the colour of laser beam is \_\_\_\_\_  
 a. Blue                      b. Violet                      c. Orange                      d. Red
9. \_\_\_\_\_ give a believable data storage in a small band width.  
 a. MP3                      b. MP4                      c. Blu-ray disc                      d. i-pod
10. \_\_\_\_\_s a device which connects all the devices into a computer  
 a. DVD                      b. USB                      c. i-pod                      d. MP3.

### II ANSWER IN FEW WORDS

1. How the speed of record player is changed?
2. Which is used to fly back the tape on tape recorder?
3. By which the CD can be made?
4. What is the capacity of storage in VCD?
5. Explain – MP4?
6. CFC, MMC, and SDC – give the size of there cards?
7. What is range of classic i-pod?
8. How many minimum number of speakers are used in a home theatre?
9. How many channels are in the dolphy?
10. Which system is used in theatre nowadays?

### III. ANSWER IN FEW LINES

1. Write notes on gramophone
2. Name the various buttons used in tape recorder
3. What are the parts in a CD?
4. Write the uses of VCD?



5. What is MP3?
6. What are the different types of DVD base on their data storage?
7. Give the storage amount of Blu-ray-disc?
8. Write sort notes on memory card?
9. Say about the other USB users?
10. What are the different kinds of i-pod?

**IV. WRITE IN A PARAGRAPH (NOT MORE THAN ONE PAGE)**

1. Explain the action of gramophone
2. How is the CD can made?
3. Say about the data storage in MP3?
4. Compare MP3 and MP4?
5. Write short notes on Blu-ray disc?
6. How can the USB used in data media?
7. Write the principle of i-pod?

**V. GIVE BRIEF ANSWERS OF THE FOLLOWING**

1. Explain briefly working of tape recorder
2. How the home theatres are formed?
3. Explain about DTS?
4. Write briefly about the Dolphy technology?

**ANS:** 1.(a), 2.(b), 3.(c), 4.(d), 5.(c), 6.(b), 7.(a), 8.(d), 9.(c), 10.(b)

## 6. TRANCEIVERS

### 6.1 INTRODUCTION OF CELLPHONE

Cell phones also known as mobile phones or wireless phones are hand-held phones with built-in antennas. Unlike home phones, cell phones can be carried from place to place with a minimum of protest. This makes them a good choice for people who want to be in touch other people even when they are away from the house.

#### 6.1.1 PRINCIPLES OF CELL PHONES

Cell phones are actually two-way radios, much like the walkie-talkies of the past, but much more advanced. When you talk into your cell phone receiver, it registers your voice and converts the sound into radio waves. These waves travel through the air until they reach a receiver, which is usually found at a base station. This station will send your call through a telephone network until it contacts the person you wish to speak with. Similarly when someone places a call to your cell phone, the signal travels through the telephone network until it reaches a station near you. The station sends the radio waves out into the neighboring areas. These radio waves are then picked up by your cell phone and converted into sound of a human voice.



**Fig 6.1 (a) structure of cell phone**

Cell phones are a vast improvement over the telecommunications technology of the past, and are daily becoming a fixture of modern life. using a cell phone is one of the first steps you must take to participate effectively in the emerging global economy.

#### 6.1.2 PCS

Personal communication service or PCS is the name for the 1900MHz radio band used for digital mobile phone services in Canada, Mexico and the United states. Code division multiple access (CDMA), GSM and D-AMPS systems can be used on PCS frequencies. The FCC, as well as industry Canada set aside the frequency band of 1850-1990 MHZ for mobile phone use in 1994, as the original cellular phone band at 800-894MHz was becoming overcrowded. Dual band GSM phones are capable of working in both 850 and 1900MHz bands. However GSM “world phones” (some of which are known as tri-band or quad-band phones) offered by North American carriers support both European, outside the USA, PCS is used to refer to GSM-1900. In Hong-kong PCS used to refer to GSM-1800.

Sprint was the first company to set up a PCS network, which was a GSM-1900network in the Baltimore- Washington metropolitan area in the USA. Eventually however, sprint converted that network to CDMA technology and sold the GSM infrastructure to Omni point, which later became part of T-mobile USA. Nowadays the PCS frequencies have been adopted for usage in most parts of the Americas.

### 6.1.3 GSM

GSM (Global system for mobile communications) is the most popular standard for mobile telephony systems in the world. The GSM Association, its promoting industry trade organization of mobile phone carriers and manufacturers, estimates that 80% of the global mobile market uses the standard. GSM is used by over 4.3 billion people across more than 212 countries and territories.

GSM differs from its predecessor technologies in that both signaling and speech channels are digitals, and thus GSM is considered a Second Generation (2G) mobile phone system. This also facilitates the wide-spread implementation of data communication applications into the system.

GSM standard has been an advantage to both consumers and also to network operators GSM also pioneered low-cost implementation of the short message service (SMS).

### 6.1.4 CDMA TRANSMISSION

Code division multiple access (CDMA) is a channel access method utilized by various radio communication technologies. It should not be confused with the mobile phone standards called cdmaOne and CDMA2000.

One of the basic concepts in data communication is the idea of allowing several transmitters to send information simultaneously over a single communication channel. This allows several users to share a bandwidth of different frequencies. This concept is called multiplexing. CDMA employs spread-spectrum technology and a special coding scheme to allow multiple users to be multiplexed over the same physical channel. CDMA is a form of spread-spectrum signaling, since the modulated coded signal has a much higher data bandwidth than the data being communicated.

An analogy to the problem of multiple access is a room (channel) in which people wish to communicate with each other. To avoid confusion, people could take turns speaking (time division), speak at different pitches (frequency division), or speak in different languages (code division). CDMA is analogous to the last example where people speaking the same language can understand each other, but not other people. Similarly, in radio CDMA, each group of users is given a shared code. Many codes occupy the same channel, but only users associated with a particular code can communicate.

### USES

A CDMA mobile phone

- One of the early applications for code division multiplexing is in GPS. This predates and is distinct from cdmaOne.
- The Qualcomm standard IS-95, marketed as cdmaOne.
- The Qualcomm standard IS-2000, known as CDMA2000. This standard is used by several mobile phone companies, including the Global star satellite phone network.
- CDMA has been used in the Omni TRACS satellite system for transportation logistics.

### 6.1.5. TDMA TRANSMISSION

Time division multiple access (TDMA) is a channel access method for shared medium networks. It allows several users to share the same frequency channel by dividing the signal into different time slots. The users transmit in rapid succession, one after the other, each using his own time slot. This allows multiple stations to share the same transmission medium (e.g. radio frequency channel) while using only a part of its channel capacity. TDMA is used in the digital 2G cellular systems such as Global

System for Mobile Communications (GSM), IS-136, Personal Digital Cellular (PDC) and iDEN, and in the Digital Enhanced Cordless.

Telecommunication (DECT) standard for portable phones. It is also used extensively in satellite systems, and combat-net radio systems.

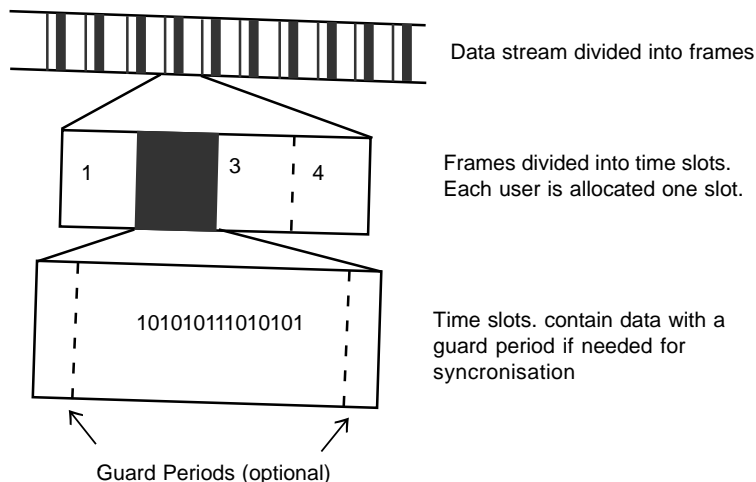

### 6.1.(b) Usage of dynamic TDMA packet mode communication

TDMA frame structure showing a data stream divided into frames and those frames divided into time slots.

#### TDMA CHARACTERISTICS

- ❖ Shares single carrier frequency with multiple users.
- ❖ Non-continuous transmission makes handoff simpler.
- ❖ Slots can be assigned on demand in dynamic TDMA
- ❖ Less stringent power control than CDMA due to reduced intra cell interference
- ❖ Higher synchronization overhead than CDMA
- ❖ Cell breathing is more complicated than in CDMA
- ❖ Frequency/slot allocation complexity
- ❖ Pulsating power envelop: Interference with other devices.

#### 6.1.5 TDMA IN MOBILE PHONE SYSTEMS

##### 2G SYSTEMS

Most 2G cellular systems, with the notable exception of IS-95, are based on TDMA, GSM, D-AMPS, PDC, iDEN, and PHS are examples of TDMA cellular systems. GSM combines TDMA with Frequency Hopping and wideband transmission to reduce interference, this minimizes common types of interference.

In the GSM system, the synchronization of the mobile phones is achieved by sending timing advance commands from the base station which instructs the mobile phone to transmit earlier and by how much. This compensates for the propagation delay resulting from the light speed velocity of radio waves. The mobile phone is not allowed to transmit for its entire time slot, but there is a guard interval at the end of each time slot. As the transmission moves into the guard period, the mobile network adjusts the timing advance to synchronize the transmission.

## 3G SYSTEMS

Although most major 3G systems are primarily based upon CDMA, time division duplexing (TDD), packet scheduling (dynamic TDMA) and packet oriented multiple access schemes are available in 3G form, combined with CDMA to take advantage of the benefits of both technologies.

### 6.2. INFRARED

Infrared radiation (IR radiation) is electromagnetic radiation with a wavelength between 0.7 and 300 micrometers, which equates to a frequency range between approximately 1 and 430 THz.

Its wavelength is longer (and the frequency lower) than that of visible light, but the wavelength is shorter (and the frequency higher) than that of terahertz radiation microwaves. Bright sunlight provides an irradiance of just over 1 kilowatt per square meter at sea level. Of this energy, 527 watts is infrared radiation, 445 watts is visible light, and 32 watts is ultraviolet radiation.

Infrared imaging is used extensively for military and civilian purposes. Military applications include target acquisition, surveillance, night vision, homing and tracking. Non-military uses include thermal efficiency analysis, remote temperature sensing, short-ranged wireless communication, spectroscopy, and weather forecasting. Infrared astronomy uses sensor-equipped telescopes to penetrate dusty regions of space, such as molecular clouds; detect objects such as planets, and to view highly red-shifted objects from the early days of the universe.

At the atomic level, infrared energy elicits vibrational modes in a molecule through a change in the dipole moment, making it a useful frequency range for study of these energy states for molecules of the proper symmetry. Infrared spectroscopy examines absorption and transmission of photons in the infrared energy range, based on their frequency and intensity.

The name means below red, the Latin *infra* meaning “below”. Red is the color of the longest wavelengths of visible light. Infrared light has a longer wavelength (and so a lower frequency) than that of red light visible to humans, hence the literal meaning of below red.

## APPLICATIONS

### INFRARED FILTERS

Infrared (transmitting/passing) filters can be made from many different materials. One type is made of polysulfone plastic that blocks over 99% of the visible light spectrum from “white” light sources. Currently in use around the world, infrared filters are used in Military, Law Enforcement, Industrial and Commercial applications.

### 1.NIGHT VISION

Active-infrared night vision: the camera illuminates the scene at infrared wavelengths invisible to the human eye. Despite a dark back-lit scene, active-infrared night vision delivers identifying details, as seen on the display monitor.



**Fig. 6.2 (a) Infra red night vision**

## 2.THERMOGRAPHY

Infrared radiation can be used to remotely determine the temperature of objects. This is termed thermography. Thermography (thermal imaging) is mainly used in military and industrial applications.

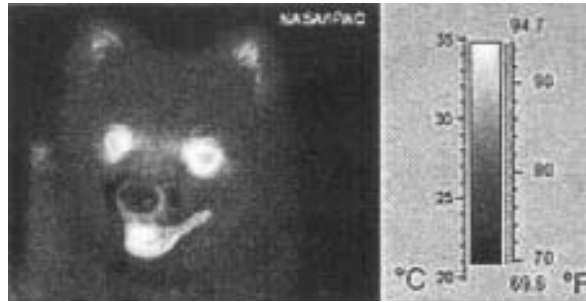

**Fig 6.2 (b) a thermographic image of a dog**

## 3.OTHER IMAGING

Infrared light from the LED of an Xbox 360 remote control as seen by a digital camera.

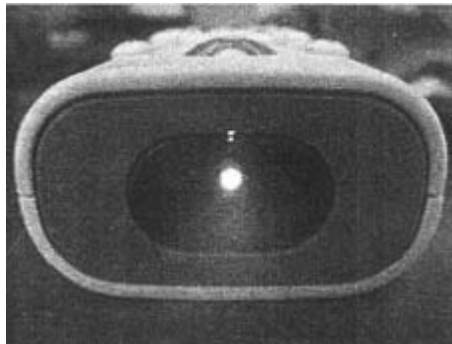

**Fig 6.2 (c) infra red light from LED is shown by the camera**

## 4. TRACKING

Infrared tracking refers to a passive missile guidance system.

## 5. HEATING

Infrared radiation can be used as a deliberate heating source. For example it is used in infrared saunas to heat the occupants, and also to remove ice from the wings of aircraft (de-icing). IR is also gaining popularity as a safe method of natural health care & physiotherapy. Infrared can be used in cooking and heating food as it predominantly heats the opaque, air around them.

Infrared heating is also becoming more popular in industrial manufacturing processes, e.g. curing of coatings, forming of plastics, annealing, plastic welding, print drying.

## 6. METEOROLOGY

IR Satellite picture taken on 15<sup>th</sup> October 2006. A frontal system can be seen in the Gulf of Mexico with embedded Cumulonimbus.

Weather satellites equipped with scanning radiometers produce thermal or infrared images which can then enable a trained analyst to determine cloud heights and types, to calculate land and surface water temperatures, and to locate ocean surface features.



**Fig 6.2 (d) satellite picture**

## **6.2.2. BLUETOOTH**

Bluetooth is an open wireless technology standard for exchanging data over short distances from fixed and mobile devices, creating personal area networks (PANs) with high levels of security. Created by telecoms vendor Ericsson in 1994, it was originally conceived as a wireless alternative to RS-232 data cables. It can connect several devices, overcoming problems of synchronization. Today Bluetooth is managed by the Bluetooth Special Interest Group.

The word Bluetooth is an anglicized version of Danish Blatand, the epithet of the tenth-century king Harald I of Denmark who united dissonant Danish tribes into a single kingdom. The implication is that Bluetooth does the same with communications protocols, uniting them into one universal standard.

Bluetooth uses a radio technology called frequency-hopping spread spectrum, which chops up the data being sent and transmits chunks of it on up to 79 bands of 1MHz width in the range 2402-2480 MHz. this is in the globally unlicensed Industrial, Scientific and Medical (ISM) 2.4 GHz short-range radio frequency band.

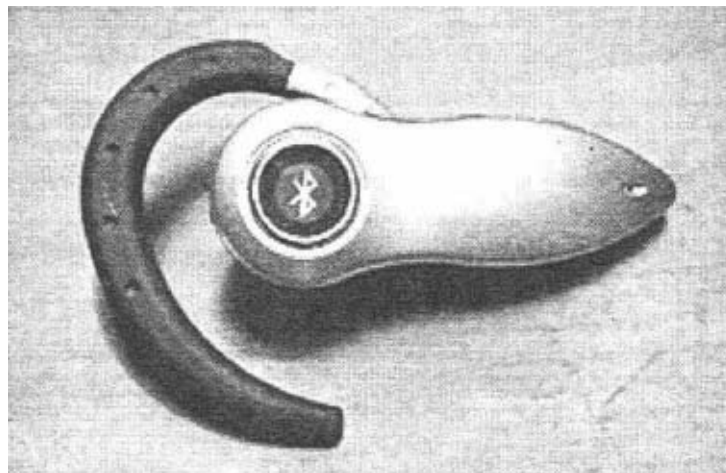

**Fig 6.2.1 (a) A typical Bluetooth mobile phone headset**

Bluetooth is a packet-based protocol with a master-slave structure. One master may communicate with up to 7 slaves in a piconet; all devices share the master's clock. In the simple case of single-slot packets the master transmits in even slots and receives in odd slots; the slave, conversely, receives in even slots and transmits in odd slots. But in all cases the master transmit will begin in even slots and the slave transmit in odd slots.

Bluetooth provides a secure way to connect and exchange information between devices such as faxes, mobile phones, telephone, laptops, personal computers, printers, Global Positioning System (GPS) receivers, digital cameras, and video game consoles.

**USES**

Bluetooth is a standard communications protocol primarily designed for low power consumption, with a short range (see table below). Because the devices use a radio (broadcast) communications system.

**MAXIMUM PERMITTED POWER RANGE**

<b>Class</b>	<b>mW</b>	<b>dBm</b>	<b>(approximate)</b>
Class 1	100	20	~ 100 meters
Class 2	2.5	4	10 meters
Class 3	1	0	1 meters

In most cases the effective range of class 2 devices is extended if they connect to a class 1 transceiver. This is accomplished by the higher sensitivity and transmission power of Class 1 devices.

<b>Version</b>	<b>Data Rate</b>
Version 1.2	1 Mbit/s
Version 2.0 + EDR	3 Mbit/s
Version 3.0 + HS	24 Mbit/s

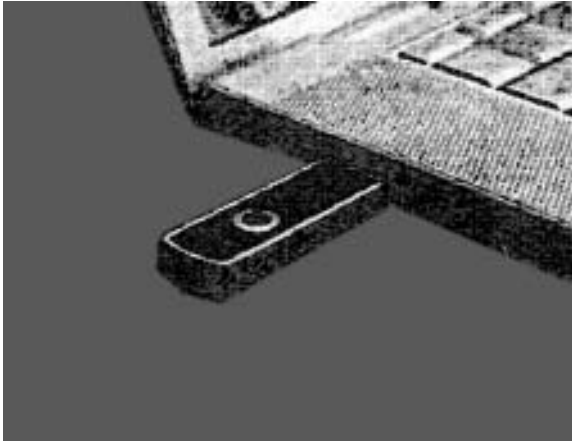

**Fig 6.2.1 (b) Blue tooth device**

**LIST OF APPLICATIONS**

A typical Bluetooth mobile phone headset

- Wireless control of and communication between a mobile phone and a hands-free headset. This was one of the earliest applications to become popular.
- Wireless networking between PCs in a confined space and where little bandwidth is required.
- Wireless communication with PC input and output devices, the most common being the mouse, keyboard and printer.
- Transfer of files, contact details, calendar appointments, and reminders between devices with OBEX.



- Replacement of traditional wired serial communications in test equipment, GPS receivers, medical equipment, bar code scanners, and traffic control devices.
- Sending small advertisements from Bluetooth (enabled advertising hoardings to other).
- Wireless bridge between two industrial Ethernet (e.g., PROFINET) networks.
- Three seventh-generation game consoles, Nintendo's Wii and Sony's PlayStation 3 and PSP Go, use Bluetooth for their respective wireless controllers.
- Dial-up internet access on personal computers of PDAs using a data-capable mobile phone as a wireless modem like Novatel mifi.
- Short range transmission of health sensor data from medical devices to mobile phone, set top box or dedicated telehealth devices.

### 6.2.3. GPRS

General Packet Radio Service (GPRS) is a mobile data service available to users of GSM mobile phones. It is often described as "2.5G", that is, a technology between the second (2G) and third (3G) generations of mobile telephony. It provides moderate speed data transfer, by using unused TDMA channels in the GSM network. Originally there was some thought to extend GPRS to cover other standards, but instead those networks are being converted to use the GSM standard, so that is the only kind of network where GPRS is in use. GPRS is integrated into GSM standards.

GPRS is different from the older Circuit Switched Data (or CSD) connection included in GSM standards. GPRS is packet-switched which means that multiple users share the same transmission channel, only transmitting when they have data to send. Web browsing receiving e-mails as they arrive and instant messaging are examples of uses. Usually, GPRS data is billed per kilobytes of information transceived while circuit switched data connections are billed per second.

GPRS class 8 is also known as 4+1. This means that 4 slots are allocated to downloading and 1 slot to uploading. This profile is appropriate for applications where data is mostly downloaded, such as web browsing. If the user reads more e-mail than he or she sends, this is also an appropriate profile.

GPRS class 10 is also known as 4+2. This means that 4 slots are allocated to downloading and 2 slots to uploading, but no more than 5 slots may be used at the same time. This profile is appropriate for applications where data is sent back.

Each slot can reach a maximum of 14.4 kilobit per second.

<b>Download</b>		<b>upload</b>
GPRS 4+1	57.6 kbit/s	14.4 kbit/s (class 8 & 10)
GPRS 3+2	43.2 kbit/s	28.8 kbit/s (class 10)
CSD	9.6 kbit/s	9.6 kbit/s
HSCSD	28.8 kbit/s	14.4 kbit/s (2+1)
HSCSD	43.2 kbit/s	14.4 kbit/s (3+1)

### GPRS SERVICES

GPRS upgrades GSM data services providing:

- Point-to-point (PTP) service: internetworking with the Internet.
- Point-to-multipoint (PT2MP) service:

- Short Message Service (SMS): bearer for SMS
- Anonymous service:
- Future enhancements:

### **6.2.3 CAMERA – DEFINITION**

Camera is a device used to take images (usually photographs), either singly or in sequence, with or without sound, success with video cameras. The name is derived from camera obscura, Latin for “dark chamber”.

Every camera consists of some kind of enclosed chamber, with an opening or aperture at one end for light to enter, and cording or viewing surface for capturing the light at the other end. This aperture is often controlled by an iris mechanism.

While the aperture controls the amount of light that enters the camera during photographing, the shutter controls the length of time that the light hits the film. For example, in lower light situations, the shutter speed should be slower to allow to capture what little light is present.

There are various ways of focusing a camera accurately. The simplest cameras have fixed focus and use a small aperture and wide – angle lens to ensure that everything within a certain range (usually around 3 meters). This is usually the kind found on one-use cameras and other cheap cameras. The camera can also have a limited focusing range or scale-focus that is indicated on the camera body. The user will guess the distance to the subject and adjust focus accordingly. On some cameras this is indicated by symbols.

Rangefinder cameras focus by means of a coupled parallax unit on top of the camera. Single – lens reflex cameras using the effective lens and a moving mirror to project the image onto a ground glass. Twin – lens reflex cameras use an objective lens a focusing lens unit in a parallel body to focus.

Additional cameras capture light onto photographic film or photographic plate. Video and digital cameras use electronics a charge coupled device (CCD) to capture images which can be transferred or stored in tape or computer memory code the camera for later playback or processing.

That capture many images in sequence are known as movie cameras. However the categories overlap, as still cameras are often used to capture moving images in special effect and modern digital cameras are often able to trivially switch between still and motion recording modes.

That take 3-D photographs are known as stereo cameras. Stereo cameras for making 3D prints or slides have twolenses side by side. Stereo cameras for making lenticular prints have 3, 4, 5 or even more lenses.

The film cameras feature data imprinting devices that can print a date on the negative itself.

Camera brands

- Canon
- Konica
- Leica
- Olympus
- Nikon
- Minolta
- Pentax
- Sony

## **6.2.5 VIDEO GRAPHICS ARRAY (VGA)**

Video Graphics Array (VGA) is a computer display standard first marketed in 1987 by IBM. VGA can be seen as an enhancement of and successor to the previous EGA and CGA graphics adapters. MCGA, also produced by IBM, was except that it was a simpler version of the VGA hardware.

The VGA supports both all points addressable graphics modes, and Alphanumeric text modes. Standard graphic modes are:

- 640 x 480 in 16 colours
- 640 x 400 in 16 colours
- 320 x 200 in 16 colours
- 320 x 200 in 256 colours (Mode 13h)

As well as the standard modes the VGA supports many of the modes of its predecessors the EGA, CGA and due to its configurable nature, un-documented modes.

### **PROGRAMMING TRICKS**

An undocumented, but popular 256colour mode called mode X was used to make available programming techniques and graphics resolutions not possible in the standard Mode 13h. This was a trade off for extra complexity and performance loss in some types of graphics operations.

### **TEXT MODES**

Standard alphanumeric text modes for the VGA are 80x25 and 40x25 text cells. Each cell may choose from on 16 available colours for its foreground and 8 colours for the background. The character may also be made to blink, or at expense of the blinking option, the background may be selected from 16 colours.

VGA adapters usually support both a monochrome and a color text mode, even though the monochrome mode almost never used. Black and white text on nearly all modern VGA adapters is drawn by using gray colored text on black background in color mode.

### **HARDWARE DETAILS**

In color mode, each screen character is actually represented by two bytes. The lower, or character byte is the usual character for the current character set, and the higher, or attribute byte is a bit field used to select various video attributes such as color, blinking, character set, and so forth.

## **6.2.5. VGA CAMERA**

While most digital cameras and other electronic devices that contain cameras no longer use the outdated VGA standard there were still a few applications where it remains useful.

### **FUNCTION**

VGA cameras are digital cameras that store their images directly inside the camera's memory or onto an attached memory card. The images can then be transferred to a computer for printing or sent to a TV screen for public viewing by connecting a cable between the camera.

### **FEATURES**

Cameras that have the VGA designation take pictures that have a resolution of 640 X 480, which means that a picture will be 640 pixels wide by 480 pixels long. Images of that size do not take up much space so most VGA cameras have small amount of internal memory.

## **TYPES OF VGA CAMERA USE**

- Cellular phones
- Toy cameras
- Megapixel rating cameras
- Binoculars

## **MISCONCEPTIONS**

The VGA rating refers only to size and not to clarity. 640 x 480 pixels is about the equivalent of a 0.3 megapixel image. The issues of distortion and clarity loss only occur when the image is either enlarged beyond its original parameters for printing or viewed on a screen that uses a larger resolution. Since most modern monitors and TV screens use a 1280 x 1024 resolution.

### **6.2.6. PIXEL TYPE**

The marketing race for “more megapixels” would like us to believe that “more is Better”. Unfortunately, it’s not that simple. The number of pixels is only one of many factors affecting image quality and more pixels is not always better. The quality of a pixel value can be described in terms of geometrical accuracy, color accuracy, dynamic range, noise, and artifacts. The quality of a pixel value depends on the number of photodetectors that were used to determine it, the quality of the lens and sensor combination, the size of the photodiode(s), the quality of the camera components, the level of sophistication of the in camera imaging processing software, the image file format used to store it, etc. different sensor and camera designs make different compromises.

## **GEOMETRICAL ACCURACY**

Geometrical accuracy is related to the number of pixel locations on the sensor and the ability of the lens to match the sensor resolution. The resolution topic explains how this is measured at this site. Interpolation will not improve geometrical accuracy as it cannot create what was not captured.

## **COLOR ACCURACY**

Conventional sensors using a color filter array have only one photodiode per pixel location and will display some color inaccuracies around the edges because the missing pixels in each color channel are estimated based on demosaicing algorithms. Increasing the number of pixel locations on the sensor will reduce the visibility of these artifacts. Foveon sensors have three photodetectors per pixel location and create therefore a higher color accuracy by eliminating the demosaicing artifacts. Unfortunately their sensitivities are currently lower than conventional sensors and the technology is only available in a few cameras.

## **DYNAMIC RANGE**

The size of pixel location and the fill factor determine the size of the photodiode and this has a big impact on the dynamic range. Higher quality sensors are more accurate and will be able to output a larger dynamic range which can be preserved when storing the pixel values into a RAW image file. A variant of the Fujifilm Super CCD, the super CCD SR uses two photodiodes per pixel location with the objective to increase the dynamic range. A more sensitive photodiode measures the shadows, while a less sensitive photodiode measures the highlights.

## 6.3 HALF-DUPLEX

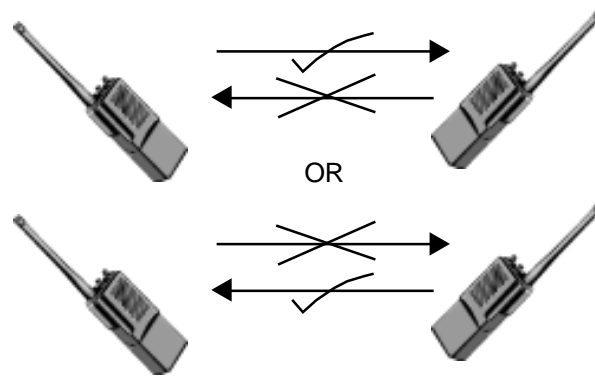

Fig. 6.3 a simple illustration of a half- duplex communication system

A half duplex system provides for communications in both directions, but only one direction at a time (not simultaneously), typically once a party begins receiving a signal, it must wait for the transmitter to stop transmitting, before replying.

An example of a half-duplex system is a two-party system such as a “walkie-talkie” style two way radio, wherein one must use “over” or another previously designated command to indicate the end of transmission, and ensure that only one party transmits at a time, because both parties transmit on the same frequency.

A good analogy for a half-duplex system would be a one lane road with traffic controllers at each end.

In automatically run communication systems, such as two way data links, the time allocations for communications in a half-duplex system can be firmly controlled by the hardware. Thus, there is no waste of the channel for switching. For example station A on one end of the data link could be allowed to transmit for exactly one second, and then station B on the other end could be allowed to transmit for exactly one second. And then this cycle repeats over and over again.

### 6.3.1 FULL-DUPLEX

A simple illustration of a full-duplex communication system although full-duplex is not common in shown handheld radios due to the cost and complexity of common duplexing methods.

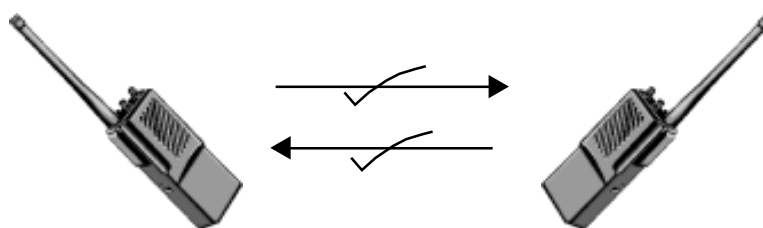

Fig.6.3.1 Fulldulex

A full duplex, or sometimes double-duplex system, allows communication in both directions, and unlike half-duplex, allows this to happen simultaneously. Land line telephone networks are full-duplex. Since they allow both callers to speak and be heard at the same time. A good analogy for a full-duplex system would be a two-lane road with one lane for each direction.

Example: Telephone, Mobile phone, etc

Two-way radios can be for instance, designed as full-duplex systems, which transmit on one frequency and receive on a different frequency. This is also called frequency-division duplex. Frequency-division duplex systems can be extended to farther distances using pairs of simple repeater stations, because the communications transmitted on any one frequency always travel in the same direction.

Full duplex Ethernet connections work by making simultaneous use of two physical pairs of twisted cable wherein one pair is used for receiving packets and one pair is used for sending packets to a directly connected device. This effectively makes the cable itself a collision free environment and doubles the maximum data capacity that can be supported by the connection.

There are several benefits to using full-duplex over half-duplex. First, time is not wasted, since no frames need to be retransmitted, as there are no collisions. Second, the full data capacity is available in both directions because the send and receive functions are separated. Third, stations (or nodes) do not have to wait until others complete their transmission, since there is only one transmitter for each twisted pair.

Historically some computer based systems of the 1960s and 1970s required full-duplex facilities even for half-duplex operation, because their poll- and response schemes could not tolerate the slight delays in reversing the direction of transmission in a half-duplex line.

### **6.3.2 CHANNEL RANGE**

A single cell in an analog cell-phone systems uses one-seventh of the available duplex voice channels. That is each cell is using one seventh of the available channels so it has a unique set of frequencies and there are no collisions.

- A cell phone carrier typically gets 832 radio frequencies to use in a city
- Each cell phone uses two frequencies per call – a duplex channel- so there are typically 395 voice channels per carrier.

Therefore each cell has about 56 voice channels available. In other words, in any cell, 56 people can be talking on their cell phone at one time. Analog cellular systems are considered first generation mobile technology, or 1G. With digital transmission methods (2G), the number of available channels increases. For example, a TDMA-based digital system (more on TDMA later) can carry three times as many calls as an analog system, so each cell has about 168 channels available.

Cell phones have low-power transmitters in them. Many cell phones have two signal strengths: 0.6 watts and 3 watts. The base station is also transmitting at low power. Low power transmitters have two advantages;

- The transmissions of a base station and the phones within its cell do not make it very far outside that cell. Both of the cells can reuse the same 56 frequencies. The same frequencies can be reused extensively across the city.
- The power consumption of the cell phone, which is normally battery operated, is relatively low. Low power means small batteries, and this is what has made handheld cellular phones possible.

The cellular approach requires a large number of base stations in a city of any size. A typical large city can have hundreds of towers. But because so many people are using cell phones, costs remain low power user. Each carrier in each city also runs one central office called the mobile telephone switching

office (MTSO). This office handles all of the phone connections to the normal land-based phone systems and controls all of the base stations in the region.

### 6.3.3 CELL-PHONE FREQUENCIES

In the dark ages before cell phones, people who really needed mobile-communications ability installed radio telephones in their cars. In the radio telephone systems, there was one central antenna tower per city, and perhaps 25 channels available on that tower. This central antenna meant that the phone in your car needed a powerful transmitter- big enough to transmit 40 or 50 miles (about 70km). It also meant that not many people could use radio telephones there just were not enough channels.

The genius of the cellular system is the division of a city into small cells. This allows extensive frequency reuse across a city, so that millions of people can use cell phones simultaneously.

A good way to understand the sophistication of a cell phone is to compare it to a CB radio or a walkie-talkie.

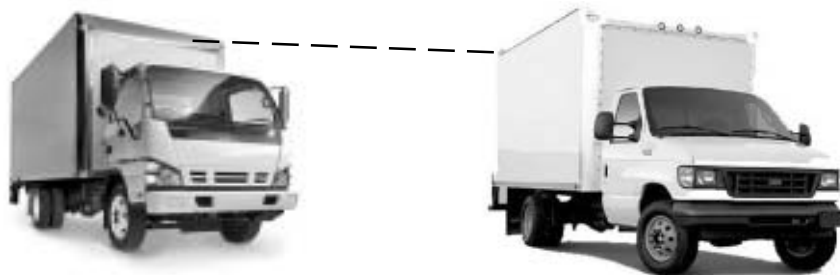

**Fig. 6.3.4 (a) Half-duplex**

- Full-duplex vs half-duplex – both walkie-talkies and CB radios are half-duplex devices. That is, two people communicating on a CB radio use the same frequency, so only one person can talk at a time. A cell phone is a full-duplex device. That means that you use one frequency for talking and a second, separate frequency for listening. Both people on the call can talk at once.
- Channels- a walkie-talkie typically has one channel, and a CB radio has 40 channels. A typical cell phone can communicate on 1,664 channels or more!

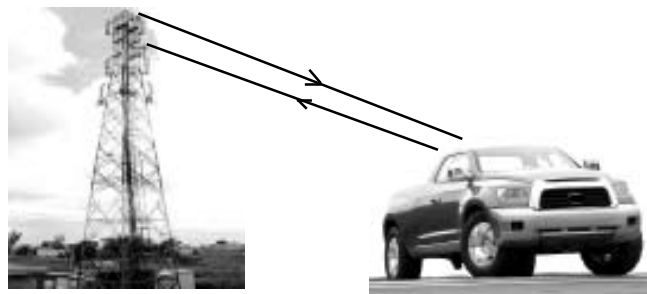

**Fig 6.3.4 (b) Full duplex**

- Range- A walkie-talkie can transmit about 1 mile (1.6km) using a 0.25watt transmitter. A CB radio, because it has much higher power, can transmit about 5 miles (8km) using a 5 watt transmitter. Cell phones operate within cells. Cells give cell phones incredible range. Someone using a cell phone can drive hundreds of miles and maintain a conversation the entire time because of the cellular approach.

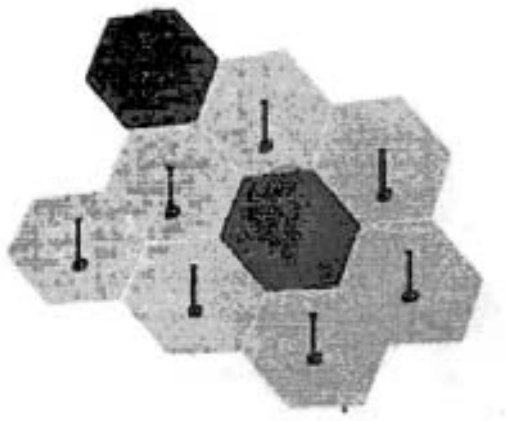

Fig 6.3.4 © Many small hexagons in a big hexagonal grid

In half-duplex radio, both transmitters use the same frequency, only one party can talk at a time.

In full duplex radio, the two transmitters use different frequencies, so both parties can talk at the same, time. Cell phones are full-duplex.

In a typical analog cell-phone system in the United States, the cell-phone carrier receives about 800 frequencies to use across the city. The carrier chops up the city into cells. Each cell is typically sized about 10 square miles (26 square Kilometers). Cells are normally thought of as many small hexagons on a big hexagonal grid.

Each cell has a base station that consists of a tower and a small building containing the radio equipment.

### **6.3.4 RADIOTELEPHONE**

A case of historic US usage of the similar word Radiophone exists in the 1960s. This term is used to describe push-to-talk two-way systems and equipment.

There may be confusion between the similar words radiophone and radiotelephone. A historic case of radiotelephone being used for two-way radio was not found. However since, the 1930s the federal communications commission has issued various commercial “radiotelephone operator” licenses and permits to qualified applicants. These allow them to install service and maintain voice-only radio transmitter systems for use on ships and aircraft.

### **ADIOTELEPHONE VERSUS PHONE**

The word phone has a long precedent beginning with early US wireless voice systems. The term means analog voice as opposed to early binary communications known as telegraph or Morse code. This would include systems fitting into the category of two-way radio or one way voice broadcasts such as coastal maritime weather. The term is still popular in the amateur radio community and in US Federal communications commission regulations.

### **6.4 WLL**

A telephone in which audio communication is established by use of a two-way radio transmitter and receiver. Also called wireless telephone.

Wireless local loop (WLL) is a term for the use of a wireless communications link as the “last mile/first mile” connection for delivering plain old telephone service (POTS) and/or broadband internet to telecommunications customers. Various types of WLL systems and technologies exist.

Other terms for this type of access include Broadband wireless Access (BWA), Radio In The Loop (RITL), Fixed Radio Access (FRA) and Fixed Wireless Access (FWA).

Wireless local loop (WLL) standards



- Mobile
  - CDMA
  - TDMA
  - GSM
  - UMTS
  - Personal handy phone system
- Fixed or local area network
  - DECT
  - LMDS
  - IEEE 802.11, Originally designed for short range mobile internet and network access service, it has emerged as the fact standard for wireless local loop.
  - WiMAX or IEEE 802.16 may become the dominant medium for wireless local loop. Currently more operators are running on the 802.11 MAC at 2 and 5GHz. Intel is promoting this standard.
  - Satellite internet access for autonomous building.

#### 6.4.1 SATELLITE TELEPHONE

A satellite telephone or sat phone is a type of mobile that connects to orbiting satellites instead of terrestrial cell sites. Depending on the architecture of a particular system, coverage may include the entire Earth, or only specific regions.

The mobile equipments also known as a terminal, varies widely. Early satellite phone handsets had a size and weight comparable to that of a late-1980s or early 1990s mobile phone, but usually with a large retractable antenna. More recent satellite phones are similar in size to a regular mobile phone sat phones are popular on expeditions into remote areas where terrestrial cellular service is unavailable.

Fixed installation such as one used aboard a ship, may include large, rugged, rack-mounted electronics, and a steerable microwave antenna on the mast that automatically tracks the overhead satellites. Smaller installations using VoIP over a two-way satellite broadband service.

### QUESTIONS

#### I. CHOOSE THE CORRECT ANSWER GIVEN BELOW

1. Originally cell phones are
 

a) Antenna	b) Walkie-talkie	c) Telephone	d) Two-way radio
------------	------------------	--------------	------------------
2. Cell phone receiver register the voice and covert it in to
 

a) Current wave	b) Radio wave	c) Light wave	d) Audio wave
-----------------	---------------	---------------	---------------
3. The phone which is called as a world phone is
 

a) PCs	b) CDMA	c) GSM	d) TDMA
--------	---------	--------	---------
4. Infra red rays means
 

a) Light rays	b) Electromagnetic rays	c) Radio waves	d) sound waves
---------------	-------------------------	----------------	----------------
5. \_\_\_\_\_ is a device which is used to take images
 

a) Camera	b) Computer	c) cell phone	d) Radio waves
-----------	-------------	---------------	----------------
6. VGA camera take picture in size of
 

a) 640x480	b) 460x480	c) 460x480	d) 640x840
------------	------------	------------	------------

7. A half- duplex gives \_\_\_\_\_ direction of communication  
 a) Single direction      b) several directions      c) both directions      d) Four directions
8. In land line telephone \_\_\_\_\_ system is used  
 a) Half-duplex      b) Full-duplex  
 c) Wireless communication      d) Satellite communication
9. A single cell gets \_\_\_\_\_ of the duplex voice channel  
 a) 1/7<sup>th</sup>      b) 5/7<sup>th</sup>      c) 1/8<sup>th</sup>      d) 7<sup>th</sup>
10. Satellite cell phone is shortly named as  
 a) Sat phone      b) Cell phone      c) Mobile phone      d) Walkie-talkie

## II. ANSWER IN ONE OR TWO WORDS

1. By which we get the calls of a cell phone?
2. Which power transmitter is used in cell phones?
3. Give two examples of full duplex
4. Which system is used in 2G cell phones?
5. What is the channel frequency of a cell phones/

## III. ANSWER IN ONE OR TWO LINES

1. What is the cell phone?
2. Expand PCS, GSM, CDMA, TDMA
3. Give the uses of CDMA
4. Where are the infra red is used?
5. What is a Blue- tooth
6. What is the work of a camera/
7. Compare, half-duplex and full duplex
8. Give the work of satellite phone
9. Write short note on a WLL
10. What are the standards of WLL?

## IV. WRITE IN A PARAGRAPH NOT EXCEED 10 LINES

1. Give the principles of cell phone
2. Write a summary about TDMA
3. Explain the channel frequency and range
4. Explain the working of radiotelephone

## V. GIVE THE ANSWER ABOUT TWO PAGES.

1. Explain the types of camera
2. Give details of cell phone frequency
3. Explain about PIXEL

**ANS:** 1. (d)      2. (b)      3. (c)      4. (b)      5(a)  
 6. (a)      7. (c)      8. (a)      9.(a)      10.(a)

## 7. DIGITAL COMPUTERS

### INTRODUCTION TO COMPUTERS

Computer is an electronic device that stores, retrieves, and processes data, and can be programmed with instructions. A computer is composed of hardware and software, and can exist in a variety of sizes and configurations.

Let us begin with the word 'compute'. It means 'to calculate'. We all are familiar with calculations in our day to day life. We apply mathematical operations like addition, subtraction, multiplication, etc. and many other formulae for calculations. Simpler calculations take less time. But complex calculations take much longer time. Another factor is accuracy in calculations. So man explored with the idea to develop a machine which can perform this type of arithmetic calculation faster and with full accuracy. This gave birth to a device or machine called '**computer**'.

The computer we see today is quite different from the one made in the beginning. The number of applications of a computer has increased, the speed and accuracy of calculation has increased. You must appreciate the impact of computers in our day to day life. Reservation of tickets in Air Lines and Railways, payment of telephone and electricity bills, deposits and withdrawals of money from banks, business data processing, medical diagnosis, weather forecasting, etc. are some of the areas where computer has become extremely useful.

However, there is one limitation of the computer. Human beings do calculations on their own. But computer is a dumb machine and it has to be given proper instructions to carry out its calculation. This is why we should know how a computer works.

### ANALOG

An analogue signal uses some attribute of the medium to convey the signal's information. For example, an aneroid barometer uses the angular position of a needle as the signal to convey the information of changes in atmospheric pressure.<sup>[2]</sup> Electrical signals may represent information by changing their voltage, current, frequency, or total charge. Information is converted from some other physical form (such as sound, light, temperature, pressure, position) to an electrical signal by a transducer which converts one type of energy into another e. g. a microphone.

The signals take any value from a given range, and each unique signal value represents different information. Any change in the signal is meaningful, and each level of the signal represents a different level of the phenomenon that it represents. For example, suppose the signal is being used to represent temperature, with one volt representing one degree Celsius. In such a system 10 volts would represent 10 degrees, and 10.1 volts would represent 10.1 degrees.

Another method of conveying an analogue signal is to use modulation. In this, some base carrier signal has one of its properties altered: amplitude modulation (AM) involves altering the amplitude of a sinusoidal voltage waveform by the source information, frequency modulation (FM) changes the frequency. Other techniques, such as phase modulation or changing the phase of the carrier signal, are also used.

**Analog systems are** electronic systems with a continuously variable signal, in contrast to digital electronics where signals usually take only two different levels. The term "analogue" describes the proportional relationship between a signal and a voltage or current that represents the signal.

## DIGITAL

A **digital** system is a data technology that uses discrete (discontinuous) values. By contrast, non-digital (or analog) systems use a continuous range of values to represent information. Although digital representations are discrete, the information represented can be either discrete, such as numbers, letters or icons, or continuous, such as sounds, images, and other measurements of continuous systems.

The word digital comes from the same source as the word digit and digitus (the Latin word for finger), as fingers are used for discrete counting.

The word digital is most commonly used in computing and electronics, especially where real-world information is converted to binary numeric form as in digital audio and digital photography.

## EVOLUTION OF DC

Now let us discuss the varieties of computers that we see today. Although they belong to the fifth generation they can be divided into different categories depending upon the size, efficiency, memory and number of users. Broadly they can be divided into the following categories.

**1.MICROCOMPUTER:** Microcomputer is at the lowest end of the computer range in terms of speed and storage capacity. Its CPU is a microprocessor. The first microcomputers were built of 8-bit microprocessor chips. The most common application of personal computers (PC) is in this category. The PC supports a number of input and output devices. An improvement of 8-bit chip is 16-bit and 32-bit chips. Examples of microcomputer are IBM PC, PC-AT .

**2.MINI COMPUTER:** This is designed to support more than one user at a time. It possesses large storage capacity and operates at a higher speed. The mini computer is used in multi-user system in which various users can work at the same time. This type of computer is generally used for processing large volume of data in an organisation. They are also used as servers in Local Area Networks (LAN).

**3.MAINFRAMES:** These types of computers are generally 32-bit microprocessors. They operate at very high speed, have very large storage capacity and can handle the work load of many users. They are generally used in centralised databases. They are also used as controlling nodes in Wide Area Networks (WAN). Example of mainframes are DEC, ICL and IBM 3000 series.

**4.SUPERCOMPUTER:** They are the fastest and most expensive machines. They have high processing speed compared to other computers. They have also multiprocessing technique. One of the ways in which supercomputers are built is by interconnecting hundreds of microprocessors. Supercomputers are mainly being used for weather forecasting, biomedical research, remote sensing, aircraft design and other areas of science and technology. Examples of supercomputers are CRAY YMP, CRAY2, NEC SX-3, CRAY XMP and PARAM from India.

## FUNDAMENTALS OF DC

### WHAT IS A COMPUTER?

A computer can be defined as an electronic data processing device, capable of accepting data, applying a prescribed set of instructions to the data, and displaying in some manner or form.

Computer is an electronic device used to do arithmetic calculations faster. But as you will see later it does much more than that. It can be compared to a magic box, which serves different purpose to different people. For a common man computer is simply a calculator, which works automatic and quite fast. For a person who knows much about it, computer is a machine capable of solving problems

and manipulating data. It accepts data, processes the data by doing some mathematical and logical operations and gives us the desired output.



Fig.7.1 Personal computer

Therefore, we may define computer *as* a device that transforms data. Data can be anything like marks obtained by you in various subjects. It can also be name, age, sex, weight, height, etc. of all the students in your class or income, savings, investments, etc., of a country. Computer can be defined in terms of its functions. It can i) accept data ii) store data, iii) process data as desired, and iv) retrieve the stored data as and when required and v) print the result in desired format.

You will know more about these functions as you go through the later lessons.

## **CHARACTERISTICS OF COMPUTER**

Let us identify the major characteristics of computer. These can be discussed under the headings of speed, accuracy, diligence, versatility and memory.

### **1. SPEED**

As you know computer can work very fast. It takes only few seconds for calculations that we take hours to complete. Suppose you are asked to calculate the average monthly income of one thousand persons in your neighborhood. For this you have to add income from all sources for all persons on a day to day basis and find out the average for each one of them. How long will it take for you to do this? One day, two days or one week? Do you know your small computer can finish this work in few seconds? The weather forecasting that you see every day on TV is the results of compilation and analysis of huge amount of data on temperature, humidity, pressure, etc. of various places on computers. It takes few minutes for the computer to process this huge amount of data and give the result.

You will be surprised to know that computer can perform millions (1,000,000) of instructions and even more per second. Therefore, we determine the speed of computer in terms of microsecond ( $10^{-6}$  part of a second) or nano-second ( $10^{-9}$  part of a second). From this you can imagine how fast your computer performs work.

### **2. ACCURACY**

Suppose some one calculates faster but commits a lot of errors in computing. Such result is useless. There is another aspect. Suppose you want to divide 15 by 7. You may work out up to 2 decimal places and say the dividend is 2.14. I may calculate up to 4 decimal places and say that the result is 2.1428. Some one else may go up to 9 decimal places and say the result is 2.142857143. Hence, in addition to speed, the computer should have accuracy or correctness in computing.

The degree of accuracy of computer is very high and every calculation is performed with the same accuracy. The accuracy level is determined on the basis of design of computer. The errors in computer are due to human and inaccurate data.

### **3. DILIGENCE**

A computer is free from tiredness, lack of concentration, fatigue, etc. It can work for hours without creating any error. If millions of calculations are to be performed, a computer will perform

every calculation with the same accuracy. Due to this capability it overpowers human being in routine type of work.

#### **4. VERSATILITY**

It means the capacity to perform completely different type of work. You may use your computer to prepare payroll slips. Next moment you may use it for inventory management or to prepare electric bills.

#### **5. POWER OF REMEMBERING**

Computer has the power of storing any amount of information or data. Any information can be stored and recalled as long as you require it, for any numbers of years. It depends entirely upon you how much data you want to store in a computer and when to lose or retrieve these data.

#### **6. NO IQ**

Computer is a dumb machine and it cannot do any work without instruction from the user. It performs the instructions at tremendous speed and with accuracy. It is you to decide what you want to do and in what sequence. So a computer cannot take its own decision as you can.

#### **7. NO FEELING**

It does not have feelings or emotion, taste, knowledge and experience. Thus it does not get tired even after long hours of work. It does not distinguish between users.

#### **8. STORAGE**

The Computer has an in-built memory where it can store a large amount of data. You can also store data in secondary storage devices such as floppies, which can be kept outside your computer and can be carried to other computers.

### **GENERATION OF COMPUTERS**

You know that the evolution of computer started from 16th century and resulted in the form that we see today. The present day computer, however, has also undergone rapid change during the last fifty years. This period, during which the evolution of computer took place, can be divided into five distinct phases known as Generations of Computers. Each phase is distinguished from others on the basis of the type of switching circuits used.

#### **1. FIRST GENERATION COMPUTERS**

First generation computers used Thermion valves. These computers were large in size and writing programs on them was difficult. Some of the computers of this generation were:

**ENIAC:** It was the first electronic computer built in 1946 at University of Pennsylvania, USA by John Eckert and John Mauchy. It was named Electronic Numerical Integrator and Calculator (ENIAC). The ENIAC was 30× 50 feet long, weighed 30 tons, contained 18,000 vacuum tubes, 70,000 registers, 10,000 capacitors and required 150,000 watts of electricity. Today your favorite computer is many times as powerful as ENIAC, still size is very small.

**EDVAC:** It stands for Electronic Discrete Variable Automatic Computer and was developed in 1950. The concept of storing data and instructions inside the computer was introduced here. This allowed much faster operation since the computer had rapid access to both data and instructions. The other advantages of storing instruction was that computer could do logical decision internally.

## **OTHER IMPORTANT COMPUTERS OF FIRST GENERATION**

**EDSAC:** It stands for Electronic Delay Storage Automatic Computer and was developed by M.V. Wilkes at Cambridge University in 1949.

**UNIVAC-1:** Ecker and Mauchly produced it in 1951 by Universal Accounting Computer setup.

## **LIMITATIONS OF FIRST GENERATION COMPUTER**

Followings are the major drawbacks of First generation computers.

1. The operating speed was quite slow.
2. Power consumption was very high.
3. It required large space for installation.
4. The programming capability was quite low.

## **2. SECOND GENERATION COMPUTERS**

Around 1955 a device called Transistor replaced the bulky electric tubes in the first generation computer. Transistors are smaller than electric tubes and have higher operating speed. They have no filament and require no heating. Manufacturing cost was also very low. Thus the size of the computer got reduced considerably.

It is in the second generation that the concept of Central Processing Unit (CPU), memory, programming language and input and output units were developed. The programming languages such as COBOL, FORTRAN were developed during this period. Some of the computers of the Second Generation were

1. IBM 1620: Its size was smaller as compared to First Generation computers and mostly used for scientific purpose.
2. IBM 1401: Its size was small to medium and used for business applications.
3. CDC 3600: Its size was large and is used for scientific purposes.

## **3. THIRD GENERATION COMPUTERS**

The third generation computers were introduced in 1964. They used Integrated Circuits (ICs). These ICs are popularly known as Chips. A single IC has many transistors, registers and capacitors built on a single thin slice of silicon. So it is quite obvious that the size of the computer got further reduced. Some of the computers developed during this period were IBM-360, ICL-1900, IBM-370, and VAX-750. Higher level language such as BASIC (Beginners All purpose Symbolic Instruction Code) was developed during this period.

Computers of this generations were small in size, low cost, large memory and processing speed is very high.

## **4. FOURTH GENERATION COMPUTERS**

The present day computers that you see today are the fourth generation computers that started around 1975. It uses large scale Integrated Circuits (LSIC) built on a single silicon chip called microprocessors. Due to the development of microprocessor it is possible to place computer's central processing unit (CPU) on single chip. These computers are called microcomputers. Later very large scale Integrated Circuits (VLSIC) replaced LSICs.

Thus the computer which was occupying a very large room in earlier days can now be placed on a table. The personal computer (PC) that you see in your school is a Fourth Generation Computer.

### 5. FIFTH GENERATION COMPUTER

The computers of 1990s are said to be Fifth Generation computers. The speed is extremely high in fifth generation computer. Apart from this it can perform parallel processing. The concept of Artificial intelligence has been introduced to allow the computer to take its own decision. It is still in a developmental stage.

### GENERATION OF LANGUAGES

Programming languages nowadays plays a major role in all kinds of problem solving. They are emerged under different levels similar to the computers. So we can say the generation for programming languages falls into three main categories as follows:

#### 1 FIRST-GENERATION LANGUAGE (MACHINE LANGUAGE)

In first-generation language, all instructions were given in the binary form and is referred to as machine language or low level language (LLL). It is very difficult for us to write or read instructions written in binaries. Consider the following instruction written in binaries.

```
0100 00011001      0101 01010011
```

#### 2 SECOND-GENERATION LANGUAGE (ASSEMBLY LANGUAGE)

In second-generation language, instructions are written with mnemonics to simplify the program. The symbolic instruction language is called assembly Language. In order to execute these instructions, all mnemonics are converted into binaries with the help of a translator known as Assembler. The program written using mnemonics is called Source Program; the binary form of the source program is called Object Program.

American Standard Code for Information Interchange (ASCII) is commonly used to translate the source program into object program. (Refer Appendix for complete ASCII list and its binary equivalents) Consider the following example which executes an assembly language program.

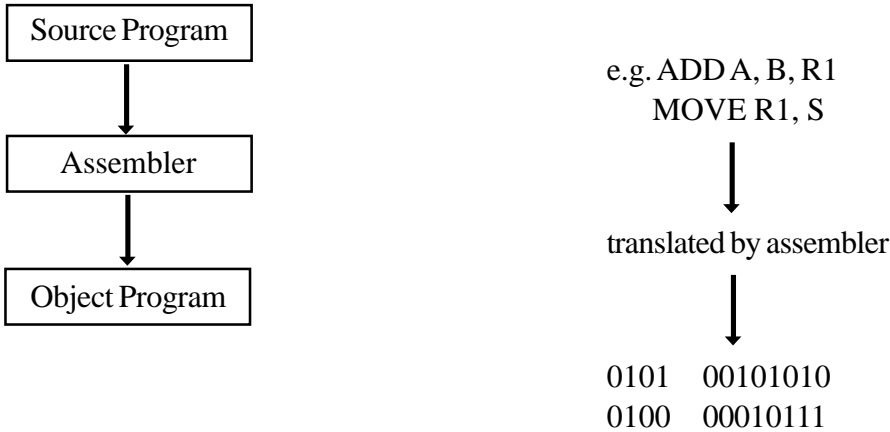

Assembly language programs are commonly used to write programs for electronic controls using microprocessors, e.g. computerized copier machine, computerized telephone billing and so on.

C language is one of the programming languages used to access the assembly language instruction as it is subroutine for any lower level programming.



### 3 THIRD-GENERATION LANGUAGES (HIGH LEVEL LANGUAGES)

In third-generation languages, instructions are written using English language with symbols and digits. Third-generation languages are also known as high level languages (HLL). The commonly used high level languages are FORTRAN, BASIC, COBOL, PASSCAL, PROLOG, C, C++, etc. The complete instruction set written in one of these languages is called a computer program or source program.

In order to execute the instructions, the source program is translated into binary form by a compiler or interpreter. A compiler is also used to translate source program written in English into an object program. An interpreter is also used for translation which translates the program line by line.

C language uses a compiler as its translator to translate or compile the complete C program. It is also necessary to create an executable program to execute the instructions given in a source program by linking the input (usually keyboard) and output (usually monitor) devices with your program. A linker (another program) is used to link the input/output devices and generate an executable program from an object program.

The command `Run` executes the executable program and allows the user to input values and get the output. An executable program can also be run by typing its filename when the computer displays the prompts `C>`, `D>` and so on. Consider the following example to execute a program. The steps in running the third generation language is given as

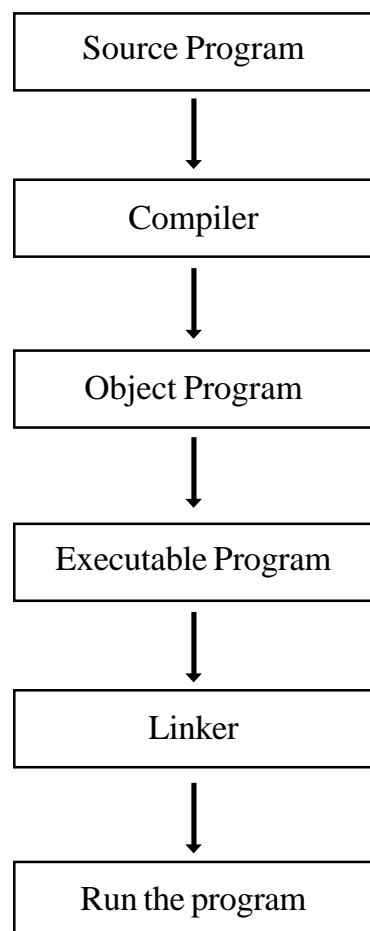



**5. CONTROL:** The manner how instructions are executed and the above operations are performed. Controlling of all operations like input, processing and output are performed by control unit. It takes care of step by step processing of all operations inside the computer.

## **FUNCTIONAL UNITS**

In order to carry out the operations mentioned above the computer allocates the task between its various functional units. The computer system is divided into three separate units for its operation. They are 1) arithmetic logical unit, 2) control unit, and 3) central processing unit.

### **ARITHMETIC LOGICAL UNIT (ALU)**

After you enter data through the input device it is stored in the primary storage unit. The actual processing of the data and instruction are performed by Arithmetic Logical Unit. The major operations performed by the ALU are addition, subtraction, multiplication, division, logic and comparison. Data is transferred to ALU from storage unit when required. After processing the output is returned back to storage unit for further processing or getting stored.

### **CONTROL UNIT (CU)**

The next component of computer is the Control Unit, which acts like the supervisor seeing that things are done in proper fashion. The control unit determines the sequence in which computer programs and instructions are executed. Things like processing of programs stored in the main memory, interpretation of the instructions and issuing of signals for other units of the computer to execute them. It also acts as a switch board operator when several users access the computer simultaneously. Thereby it coordinates the activities of computer's peripheral equipment as they perform the input and output. Therefore it is the manager of all operations mentioned in the previous section.

### **CENTRAL PROCESSING UNIT (CPU)**

The ALU and the CU of a computer system are jointly known as the central processing unit. You may call CPU as the brain of any computer system. It is just like brain that takes all major decisions, makes all sorts of calculations and directs different parts of the computer functions by activating and controlling the operations.

A central processing unit (CPU) or processor is an electronic circuit that can execute computer programs, which are actually sets of instructions. This term has been in use in the computer industry at least since the early 1960s. The form, design and implementation of CPUs have changed dramatically since the earliest examples, but their fundamental operation remains much the same.

- The CPU executes a series of instructions by looping through an instruction cycle.
- The speed of the instruction cycle is controlled by the CPU's clock.
- The CPU executes computer instructions
- Popular CPU's: Intel-Pentium, AMD, Power PC
- It is on a chip called the microprocessor.

### **COMPONENTS OF CPU**

There are three main components of the CPU: the arithmetic-logic unit (ALU), control unit and on-board cache memory.

**1. CONTROL UNIT:** The control unit is responsible for loading and interpreting the individual instructions that comprise the computer program. These instructions are in a language called **machine code**. Machine code is a pattern of ones and zeros. The control unit also has the task of getting the data needed by the instructions and returning the results of the processing after the instruction has been executed.

**2. ARITHMETIC-LOGIC UNIT:** The ALU is responsible for carrying out arithmetic operations such as addition and subtraction as well as logical decisions such as whether one number is bigger than another. All programs consist of complex sets of arithmetic and logical operations. Another way of thinking of a logical operation is as a decision making operation.

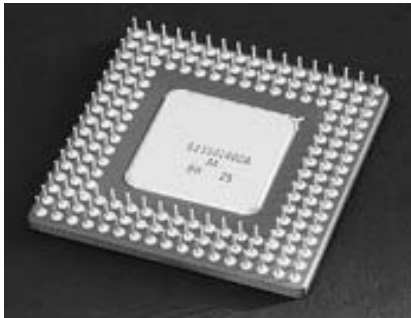

**Fig. A Processor**

**3. ON-BOARD CACHE MEMORY:** Because the CPU can perform its operations much faster than data can be transferred from RAM, many CPUs have on-board cache memory. This is memory that the control unit can access very quickly and use for intermediate storage. Further, data and instructions can be loaded into cache before they are actually needed. When they are needed, the transfer is much faster than it would have been if RAM had been used.

## INPUT DEVICES — “How to tell it what to do”

For example, keyboard and mouse are the standard way to interact with the computer. Other devices include joysticks and game pads used primarily for games.

The **MOUSE** Used to ‘drive’ Microsoft Windows

The mouse is a point and click device. As you move the mouse across a surface, it senses this movement either mechanically or optically. This is translated into the movement of a pointer on the screen. Functions are represented as icons on the screen. When you click on these using a mouse button, the function is executed.



The **KEYBOARD** is still the commonest way of entering information into a computer. The most familiar input device is the keyboard. Users type the text directly into the computer. There are a number of layouts of the keyboard. The most important are the language variations. For example, the US and UK keyboards are quite similar but are very different from the French keyboard.

**TRACKER BALLS** an alternative to the traditional mouse and often used by graphic designers A trackball acts as a type of overturned mouse. The ball is on the top side of the object. By rolling the ball you can move the pointer across the screen. Some keyboards have an in-built trackball.



## SCANNERS



A scanner allows you to scan printed material and convert it into a file format that may be used within the PC Scanners “digitize” printed material (like photos and graphics) and save it to a graphic file format (like .GIF or .JPG) for display on the computer.

## TOUCHPADS

A device that lays on the desktop and responds to pressure. A touchpad is a device that senses pressure to guide the pointer on the computer screen. It is generally a small square area below the keyboard. As the user moves his/her finger across the touchpad, the pointer moves on the screen. Next to the pad are two buttons used for clicking in exactly the same way as those on a mouse.



## LIGHT PENS



Light pens are used to allow users to point to areas on a screen. A light pen is a device which is sensitive to variations in patterns on a surface. Light pens act like a miniature scanner and can read text as they are dragged across the printed page. This can be transferred directly to the current open document.

## JOYSTICKS

Many games require a joystick for the proper playing of the game. A joystick is a device that is familiar for use in games to move objects on the screen. However, it is also used to control the movements in computerised industrial machines as lathes



## Output Devices — “How it shows you what it is doing”



For example, monitor (the screen) is how the computer sends information back to you, whether it be surfing the web or writing a memo. A printer is also an output device.

**CRT SCREENS:** The cathode ray tube (CRT) type screen is usually called a **monitor** and makes use of the same technology as a television screen.

**SOLID STATE SCREENS:** Solid state screens, also known as LCD or Liquid Crystal Displays, make use of tiny transistors to emit light and create an image. Originally, LCD screens were confined to laptops.

## PRINTERS

There are different types of printers (laser, ink jet, dot matrix) with differing quality of output. They are measured in dpi (dots per inch) and ppm (pages per minute), the higher the better. There are many different types of printers. In large organizations laser printers are most commonly used due to the fact that they can print very fast and give a very high quality output.



	<b>Dot matrix</b>	<b>Inkjet</b>	<b>Laser</b>
<b>Initial cost</b>	Low	Medium	High
<b>Cost per printed page</b>	Low	High	Medium
<b>Speed</b>	Low	Medium	High
<b>High volumes</b>	No	No	Yes
<b>Noise level</b>	High	Low	Low
<b>Print quality</b>	Low	Medium	High

## PLOTTERS

A plotter is an output device similar to a printer, but normally allows you to print larger images. A plotter consists of a device that can move paper both backwards and forwards. On the top of the device one or more pens are able to move horizontally across the paper. The combined movement of the pens horizontally across the paper and the vertical movement of the paper allows complex continuous diagrams to be drawn. Some plotters allow different colour pens to be used to create diagrams in multiple colours.



## SPEAKERS



Modern computers using the appropriate software can turn text in a document into audible speech. This is known as **speech synthesis**. Other types of software allow music and other sounds to be created and played back.

The line between the computer and a home entertainment system is becoming blurred. Computers are able to play music directly from a CD or play a film from a DVD. You can even fit your computer with a radio or TV card to add these functions.

## COMPILERS AND INTERPRETERS

Compilers convert the program instructions from human understandable form to the machine understandable form and the translated program instruction is called object code. Also note that the compiler is nothing but a language translator used to translate the entire program of the high level language into machine language. Each programming language requires its own compiler to translate the program. For example, the programming language FORTRAN requires FORTRAN compiler and C uses Compiler.

Interpreters also convert the source program to machine language instruction but execute each line as it is entered.

## COMPARISON BETWEEN A COMPILER AND AN INTERPRETER

Compiler	Interpreter
A Computer is used to compile an entire program and executable program is generated through the object program	An interpreter is used to translate each line of the program instruction immediately as it is entered.
The executable program is stored in a disk for future use or to run it in another computer.	The executable programs generated in RAM and the interpreter is required for each run of the program.
The compiled programs run faster.	The interpreted programs run slower.
Most of the languages use compilers.	A very few languages use interpreters.

## QUESTIONS

### I. CHOOSE THE BEST ANSWER

1. Computer is \_\_\_\_\_ that stores, retrieves and process data  
 a) Electronic device    b) Electrical device    c) Mechanical device    d) Instrument
2. Computers has the power of \_\_\_\_\_ any amount of information or data.  
 a) Controlling    b) stopping    c) Calling    d) Storing
3. Computer can performs \_\_\_\_\_ of Instruction and even more per second  
 a) Thousands    b) Millions    c) Hundreds    d) Five Thousands
4. EDVAC was developed by \_\_\_\_\_ at Cambridge University in 1949.  
 a) M. V. Wilkes    b) Marconi    c) J.L. Baird    d) Armstrong
5. The ALU and the CU of a computer system are jointly known as the \_\_\_\_\_  
 a) Arithmetic and Logical Unit    b) Control Unit  
 c) Central processing Unit    d) Storage Unite
6. The 'Mouse' is used to drive the \_\_\_\_\_  
 a) Key board    b) Printer    c) disc    d) Microsoft Windows
7. The Key board is the common way of entering \_\_\_\_\_ into a computer  
 a) Information    b) Charts    c) Maps    d) Writing
8. The cathode ray tube screen is usually called a \_\_\_\_\_  
 a) Monitor    b) Key board    c) Mouse    d) Printer
9. Plotter is \_\_\_\_\_ device similar to a printer.  
 a) Input    b) Output    c) Data    d) Telephone
10. \_\_\_\_\_ Converts the programme instruction from human understandable form to the machine understandable form.  
 a) Compilers    b) Printers    c) Key board    d) disc

### II. ANSWER IN ONE OR TWO WORDS

1. What is a computer?
2. Expand – CPU
3. Expand – ALU
4. State any two input devices
5. What is joystick?

### **III. ANSWER ONE OR TWO LINES**

1. What are the major functions of the storage unit?
2. What is main Function of the control unit?
3. What is the function of ALU?
4. State any four out put devices.
5. State any three types of printers.

### **IV. ANSWER ABOUT ONE PAGE**

1. Explain about analog and digital computer.
2. Explain any two input devices with neat sketch.
3. Explain any two output devices with neat sketch.
4. Explain the characteristic of computer
5. Explain : 1. CPU 2. ALU 3. Control unit

### **V. ANSWER BRIEFLY**

1. Explain generation of computers
2. Explain the basic computer operation with block diagram.
3. Explain the input and output devices of computers.

**ANS :** 1)a 2)d 3)b 4)a 5)c 6)d 7)a 8)a 9)a 10)a



## 8. NETWORK ANTENNA AND PROPAGATION

### 8.1 INTRODUCTION – OFC

An **optical fiber cable** is a cable containing one or more optical fibers. The optical fiber elements are typically individually coated with plastic layers and contained in a protective tube suitable for the environment where the cable will be deployed.



Fig. 8.1 A TOSLINK optical fibre cable with a clear jacket.

### DESIGN



Fig. 8.2 A multi-fiber cable  
Right: SC/PC connectors



Fig. 8.3 Left: LC/PC connectors



Fig. 8.4 An overview of  
Cable

In practical fibers, the cladding is usually coated with a tough resin buffer layer, which may be further surrounded by a jacket layer, usually plastic. These layers add strength to the fiber but do not contribute to its optical wave guide properties. Rigid fiber assemblies sometimes put light-absorbing (“dark”) glass between the fibers, to prevent light that leaks out of one fiber from entering another. This reduces cross-talk between the fibers, or reduces flare in fiber bundle imaging applications.

All four connectors have white caps covering the ferrules.

For indoor applications, the jacketed fiber is generally enclosed, with a bundle of flexible fibrous polymer strength members like Aramid (e.g. Twaron or Kevlar), in a lightweight plastic cover to form a simple cable. Each end of the cable may be terminated with a specialized optical fiber connector to allow it to be easily connected and disconnected from transmitting and receiving equipment.

### CABLE TYPES

- OFC: Optical fiber, conductive
- OFN: Optical fiber, nonconductive
- OFCG: Optical fiber, conductive, general use

- OFNG: Optical fiber, nonconductive, general use
- OFCP: Optical fiber, conductive, plenum
- OFNP: Optical fiber, nonconductive, plenum
- OFCR: Optical fiber, conductive, riser
- OFNR: Optical fiber, nonconductive, riser
- OPGW: Optical fiber composite overhead ground wire

## **8.2 MICROWAVE TRANSMISSION AND RECEPTION**

Microwave transmission involves the sending and receiving of microwave signals over a microwave link. This microwave link is made up of a string of microwave radio antennas located at the top of towers at various microwave sites.

### **MICROWAVE TRANSMISSION IS CONSIDERED A ‘LINE OF SITE’ TECHNOLOGY:**

Microwave transmission is considered a ‘Line of Site’ technology. This is because the proper functioning of microwave transmission requires that the airspace between two microwave towers in clear of mountains, buildings, and other objects that could possibly block signals from being intercepted by the towers. Microwave transmission is limited by this need for a clear line of sight, in addition to being susceptible to attenuation by the atmosphere. For these reasons, microwave transmission is only widely used in areas inaccessible by LAN or other transport methods.

### **ANALOG OR DIGITAL OPTIONS WITH MICROWAVE TRANSMISSION:**

Microwave equipment can be used to transmit both analog and digital microwave signals. Analog microwave transmission is often a more cost-effective solution for microwave site operators because it doesn’t require the purchase of any new equipment, or training staff on new transport systems. An additional benefit of familiar analog microwave transmission is that your operators know its exact transport capacity.

Users of digital microwave transmission find it easier to obtain support and equipment for their systems, because digital transmission is the newest, most advanced form of microwave communication. Digital microwave transmission methods can support more verbose protocols, enabling increased data exchange along the microwave network. The increased speeds will also provide faster microwave system polls.

### **MONITORING YOUR MICROWAVE TRANSMISSION EQUIPMENT PROTECTS YOUR REPUTATION:**

No matter what your microwave transmission method, you need to monitor all of your mission-critical microwave equipment. Monitoring enables you to quickly respond to microwave transmission errors, quickly bringing your network back online to protect your revenues, as well as your reputation with your customers.

### **TROUBLESHOOT YOUR MICROWAVE TRANSMISSION USING RING POLLING:**

Because microwave sites are generally found in a ring formation, you can use your network monitoring system to perform advanced monitoring applications. One such technique for determining the locations of problems is ring polling. This troubleshooting technique will also allow you to continue microwave transmission during a break between individual sites.

Microwave data is sent from site to site sequentially, and can be sent from either side. This is known as 'backhauling'. During a break, you can continue transmitting data by simply sending messages in two directions. This will also allow you to identify where a problem has occurred by identifying at which site the microwave transmission is being stopped.

### **SAFEGUARD YOUR MICROWAVE TRANSMISSION EQUIPMENT WITH A KDA 864 RTU:**

The KDA 864 RTU is advanced remote that can be used for your ring polls and other microwave monitoring functions. Packed into a compact, 19-inch unit, the KDA 864 includes 64 alarm points and 8 control points. KDA RTU's can also be connected to up to three additional units to provide you with the maximum point capacity for your microwave sites. The KDA can work with your 202 modems along microwave base bands of 0-4, and FSK modems on 4-8 and 8-12 base bands. With support for a number of different protocols, the KDA 864 will give you the visibility you must have of your microwave transmission equipment.

### **8.3 TYPES OF SATELLITES AND THEIR APPLICATIONS**

Satellites can be classified by their functions. Satellites are launched into space to do a specific job. The type of satellite that is launched to monitor cloud patterns for a weather station will be different than a satellite launched to send television signals across Canada. The satellite must be designed specifically to fulfill its function.

Below are the names of nine different types of satellites. There are also nine pictures of satellites. They are given as follows with an example satellite.

Astronomy satellites

Atmospheric Studies satellites

Communications satellites

Navigation satellites

Reconnaissance satellites

Remote Sensing satellites

Search and Rescue satellites

Space Exploration satellites

Weather satellites

### **ASTRONOMY SATELLITES**

An astronomy satellite is basically a really big **telescope** floating in space. Because it is in orbit above the Earth, the satellite's vision is not clouded by the gases that make up the Earth's **atmosphere**

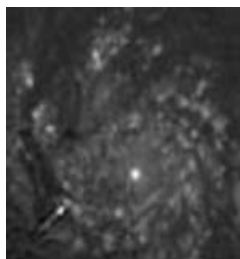

Supernova

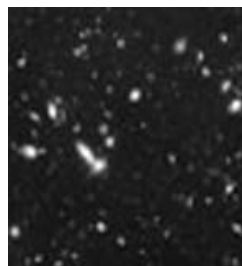

Distant galaxies

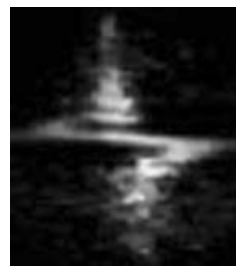

Black hole



Quasar

Fig. 8.5 View of Satellite

Astronomy satellites have many different applications:

- they can be used to make star maps
- they can be used to study mysterious phenomena such as black holes and quasars
- they can be used to take pictures of the planets in the solar system
- they can be used to make maps of different planetary surfaces

## **COMMUNICATIONS SATELLITE**

It is difficult to go through a day without using a communications satellite at least once. Do you know when you used a communications satellite today? Did you watch T.V.? Did you make a long distance phone call, use a cellular phone, a fax machine, a pager, or even listen to the radio? Well, if you did, you probably used a communications satellite, either directly or indirectly.

Communications satellites allow radio, television, and telephone transmissions to be sent live anywhere in the world. Before satellites, transmissions were difficult or impossible at long distances. The signals, which travel in straight lines, could not bend around the round Earth to reach a destination far away. Because satellites are in orbit, the signals can be sent instantaneously into space and then redirected to another satellite or directly to their destination.

The satellite can have a passive role in communications like bouncing signals from the Earth back to another location on the Earth; on the other hand, some satellites carry electronic devices called **transponders** for receiving, amplifying, and re-broadcasting signals to the Earth.

## **NAVIGATIONS SATELLITE**

Satellites for navigation were developed in the late 1950's as a direct result of ships needing to know exactly where they were at any given time. In the middle of the ocean or out of sight of land, you can't find out your position accurately just by looking out the window.

## **SPACE EXPLORATION SATELLITES**

Space exploration satellites are not really satellites at all; they are properly known as space probes. A satellite is defined as something that's orbiting something else, but space probes instead travel deep into the solar system. However, they are similar to orbiting satellites in design and function.

On their journeys, space probes send back detailed pictures and other data of faraway planets and other stellar phenomena. Space exploration satellites are responsible for many of astronomy's most important achievements. Jupiter's rings, for example, were discovered by a space exploration satellite.

Space exploration satellites must be built to last because it takes so long for the satellites to reach their destinations. Space exploration satellites are different from astronomy satellites because they do not operate from Earth orbit; they are actually sent out into deep space on their own.

An example of a space exploration satellite is NASA's Galileo.

## **WEATHER SATELLITES**

Because of weather satellite technology and communications satellite technology, you can find out the weather anywhere in the world any time of the day. There are television stations that carry weather information all day long. **Meteorologists** use weather satellites for many things, and they rely on images from satellites. Here are a few examples of those uses:

- Radiation measurements from the earth's surface and atmosphere give information on amounts of heat and energy being released from the Earth and the Earth's atmosphere.
- People who fish for a living can find out valuable information about the temperature of the sea from measurements that satellites make.

**RADAR** is an object detection system that uses electromagnetic waves to identify the range, altitude, direction, or speed of both moving and fixed objects such as aircraft, ships, motor vehicles, weather formations, and terrain.



#### 8.4 Radar

A radar system has a transmitter that emits radio waves. When they come into contact with an object they are scattered in all directions. The signal is thus partly reflected back and it has a slight change of wavelength (and thus frequency) if the target is moving. The receiver is usually, but not always, in the same location as the transmitter. Although the signal returned is usually very weak, the signal can be amplified through use of electronic techniques in the receiver and in the antenna configuration. This enables radar to detect objects at ranges where other emissions, such as sound or visible light, would be too weak to detect. Radar uses include meteorological detection of precipitation, measuring ocean surface waves, air traffic control, police detection of speeding traffic, military applications, or to simply determine the speed of a baseball.

In 1895, Alexander Popov, a physics instructor at the Imperial Russian Navy school in Kronstadt, developed an apparatus using a coherer tube for detecting distant lightning strikes. The next year, he added a spark-gap transmitter. During 1897, while testing this in communicating between two ships in the Baltic Sea, he took note of an interference beat caused by the passage of a third vessel. In his report, Popov wrote that this phenomenon might be used for detecting objects, but he did nothing more with this observation.



Fig. 8.7 A long range radar antenna ALTAIR

## **APPLICATIONS OF RADAR**

The information provided by radar includes the bearing and range (and therefore position) of the object from the radar scanner. It is thus used in many different fields where the need for such positioning is crucial. The first use of radar was for military purposes; to locate air, ground and sea targets. This has evolved in the civilian field into applications for aircraft, ships and roads.

Marine radars are used to measure the bearing and distance of ships to prevent collision with other ships, to navigate and to fix their position at sea when within range of shore or other fixed references such as islands, buoys, and lightships. In port or in harbour, Vessel traffic service radar systems are used to monitor and regulate ship movements in busy waters. Police forces use radar guns to monitor vehicle speeds on the roads.

Radar has invaded many other fields. Meteorologists use radar to monitor precipitation. It has become the primary tool for short-term weather forecasting and to watch for severe weather such as thunderstorms, tornadoes, winter storms precipitation types, etc... Geologists use specialised ground-penetrating radars to map the composition of the Earth crust. The list is getting longer all the time.

## **PRINCIPLES**

The radar dish, or antenna, transmits pulses of radio waves or microwaves which bounce off any object in their path. The object returns a tiny part of the wave's energy to a dish or antenna which is usually located at the same site as the transmitter. The time it takes for the reflected waves to return

to the dish enables a computer to calculate how far away the object is, its radial velocity and other characteristics.

## **SONAR**

**Sonar** (originally an acronym for **SOund Navigation And Ranging**) is a technique that uses sound propagation (usually underwater, as in Submarine navigation) to navigate, communicate with or detect other vessels. Two types of technology share the name “sonar”: passive sonar is essentially listening for the sound made by vessels; active sonar is emitting pulses of sounds and listening for echoes. Sonar may be used as a means of acoustic location and of measurement of the echo characteristics of “targets” in the water. Acoustic location in air was used before the introduction of radar. Sonar may also be used in air for robot navigation, and SODAR (an upward looking in-air sonar) is used for atmospheric investigations. The term sonar is also used for the equipment used to generate and receive the sound. The acoustic frequencies used in sonar systems vary from very low (infrasonic) to extremely high (ultrasonic). The study of underwater sound is known as underwater acoustics or hydroacoustics.



Fig.8.8

## **PERFORMANCE FACTORS**

The detection, classification and localisation performance of a sonar depends on the environment and the receiving equipment, as well as the transmitting equipment in an active sonar or the target radiated noise in a passive sonar.

## **SOUND PROPAGATION**

Sonar operation is affected by variations in sound speed, particularly in the vertical plane. Sound travels more slowly in fresh water than in sea water, though the difference is small. The speed is determined by the water's bulk modulus and mass density. The bulk modulus is affected by temperature, dissolved impurities (usually salinity), and pressure. The density effect is small.

## ACTIVE SONAR

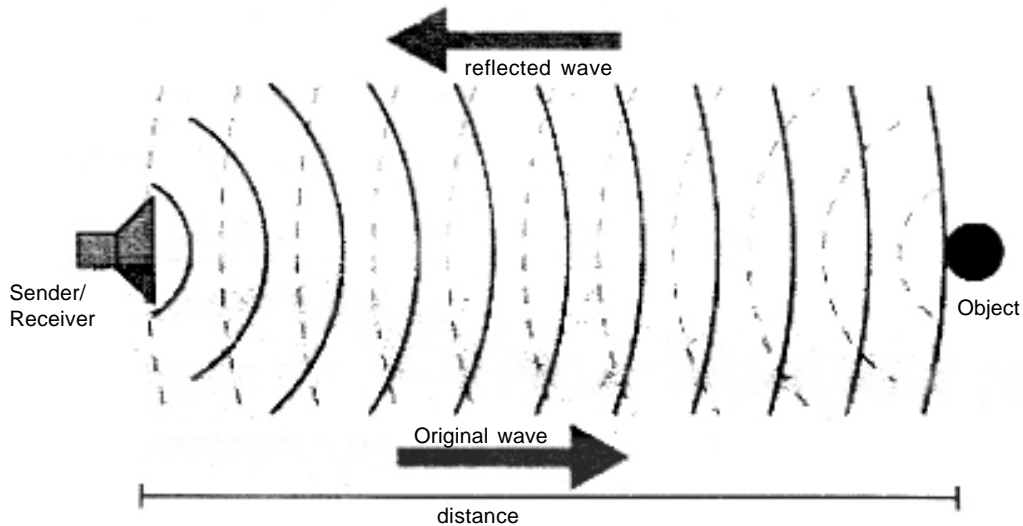

Fig.8.9 Principle of active sonar

## QUESTIONS

### I. CHOOSE THE BEST ANSWERE

1. Microwave Transmission involves the Sending and Receiving of \_\_\_\_\_ over a microwave link  
a) Radio Signals    b) Microwave Signals    c) Audio Signals    d) Modulated Signals
2. Microwave Transmission is considered a \_\_\_\_\_ technology  
a) Line Site    b) Wave    c) Single    d) Link
3. Microwave equipment can be used \_\_\_\_\_ both anolog and digital microwave signals  
a) Sending    b) Transferred    c) Transmit    d) Link
4. Microwave monitoring function advanced remote used. That is called \_\_\_\_\_  
a) KDA 864 RTV    b) KDA 812 RTV    c) KDA 836 RTV    d) KDA 846 RTV
5. Satellites are \_\_\_\_\_ in to space to do a specific job  
a) Floated    b) launched    c) Removed    d) Stopped
6. An astronomy satellite is basically a really big \_\_\_\_\_ floating in the space  
a) Binocular    b) ball    c) kite    d) telescope
7. Communication satellites allow radio, television and telephone \_\_\_\_\_ to be sent live anywhere in the world  
a) Transducer    b) transmission    c) data    d) News
8. A radar system has a transmitter that units \_\_\_\_\_  
a) Radio waves    b) RFwaves    c) AF wave    d) Modulated waves
9. Radar is an \_\_\_\_\_ detection system  
a) Object    b) wave    c) water    d) metal
10. Active sonar uses a \_\_\_\_\_ transmitter and a receiver  
a) sound    b) light    c) wave form    d) IF wave

### II. ANSWERE IN ONE OR TWO WORDS

1. Define OFC?
2. State two types of OFC



3. Define Microwave link
4. State two types of satellites.
5. What is meant by Radar?

### **III. ANSWERE IN ONE OR TWO WORDS**

1. Define microwave Transmission and Reception.
2. What are functions of communication satellite?
3. State any two application of Radar.
4. Define Performance factors of Sonar.
5. Define Navigation Satellite

### **IV. ANSWERE IN ONE OR TWO WORDS**

1. Explain about microwave Transmission and Reception.
2. Explain about Communication Satellites.

### **V. ANSWERE IN ONE OR TWO WORDS**

1. Explain the function of Radar.
2. Explain the function Sonar.

### **ANSWERS**

1) b    2) a    3) c    4) a    5) b    6) d    7) b    8) a    9) a    10) a

## 9. MEDICAL ELECTRONIC EQUIPMENT

### 9.1 INTRODUCTION:

Medical equipment is designed to aid in the diagnosis, monitoring or treatment of medical conditions. These devices are usually designed with rigorous safety standards. The *medical equipment* is included in the category *Medical technology*.

There are several basic types:

- Diagnostic equipment includes medical imaging machines, used to aid in diagnosis. Examples are ultrasound and MRI machines, PET and CT scanners, and x-ray machines.
- Therapeutic equipment includes infusion pumps, medical lasers and LASIK surgical machines.
- Life support equipment is used to maintain a patient's bodily function. This includes medical ventilators, anaesthetic machines, heart-lung machines, ECMO, and dialysis machines.
- Medical monitors allow medical staff to measure a patient's medical state. Monitors may measure patient vital signs and other parameters including ECG, EEG, blood pressure, and dissolved gases in the blood.
- Medical laboratory equipment automates or helps analyze blood, urine and genes.
- Diagnostic Medical Equipment may also be used in the home for certain purposes, e.g. for the control of diabetes mellitus

A biomedical equipment technician (BMET) is a vital component of the healthcare delivery system. Employed primarily by hospitals, BMETs are the people responsible for maintaining a facility's medical equipment.

### INVENTIONS

- 1895, X-ray, by Wilhelm Röntgen
- 1903, electrocardiograph, by Willem Einthoven
- 1956, endoscope, by Basil Hirschowitz
- 1958, ultrasound scan, by Ian Donald
- 1973, CT (CAT) scan, by Godfrey Hounsfield and Allan Cormack
- 1982, artificial heart, by Robert Jarvik

### 9.2 ELECTROCARDIOGRAM:

#### ELECTROCARDIOGRAPHY:

#### PRINCIPLE:

It is an instrument which records the electrical activity of heart. It provides information about cardiac disorders. It is used in catheterization, coronary care units and diagnostics applications. Low frequency range is essential to ensure stability of baseline. High frequency response is a compromise of several factors like isolation between a useful ECG signals from other signals. Instability of baseline, originating from the changes of the contact impedance demands the application of automatic baseline stabilizing circuit.

## DESCRIPTION:

The potentials picked up by the patient electrodes are taken to the load selector switch. By capacitive coupling the signal is connected symmetrically to the long tail pair differential pre-amplifier. The pre-amplifier is four stage differential amplifiers. The amplified output signal is picked up single ended and given to power amplifier. The output of power amplifier is single ended and fed to pen motor. Frequency selective network is an R-C network. The stylus moved in response to input signal but paper is stationary.

## PROCEDURE:

- The leads are placed in arms and legs.
- Squeeze the ECG gel into the skin at the chosen location and rub so that slight reddening occurs.
- Clip on limb node to patient table to correspond electrode avoiding to markings provided by electrode lead wires.
- Press ON/OFF button.
- Test lead will light up indicating power is ON. Adjust stylus to the centres.
- Press start and the paper starts moving.
- Press 1 mv and then adjust stylus temperature. Select lead position.

## APPLICATION:

To detect cardiac disorder.

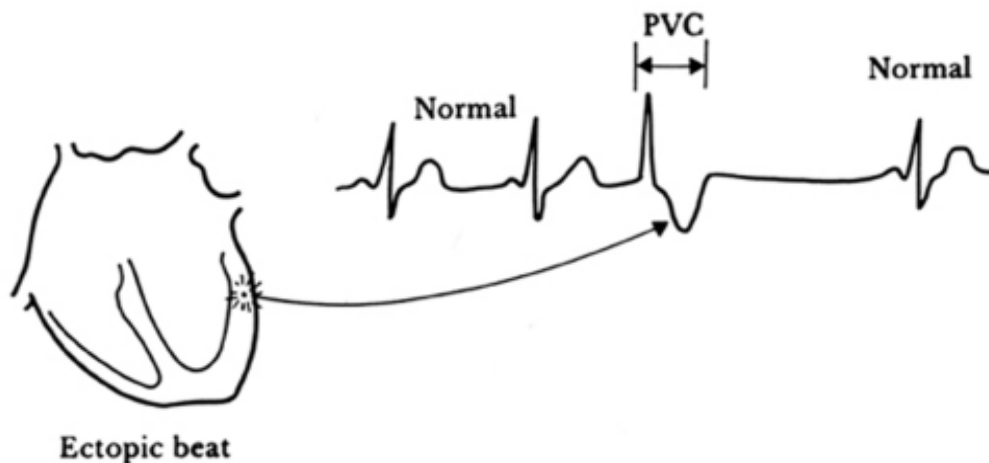

Fig. 9.1 Normal ECG Wave

## 9.3. COMPUTED TOMOGRAPHY SCAN AND ULTRASOUND:

### COMPUTED TOMOGRAPHY:

#### PRINCIPLE:

A CT scanner is a special kind of x-ray machine. Instead of sending a single beam of x-ray through the body as with ordinary x-rays, several beams are sent simultaneously from different angles.

#### THEORY AND WORKING:

The CT scanner was originally designed to take images of the brain. Now it is much more advanced and is used for taking pictures of virtually any part of the body. If the patient is receiving an abdomen scan, for eg: they will be asked not to eat for six hours before the test. They will be given a

drink containing gastrografin an unused flavoured x-ray dye, 45 minutes before the procedure. This makes the intestine easier to see on the picture. Sometimes a liquid x-ray dye is injected into the veins during the test.

The scanner looks like a large doughnut. During the scan the patient lies on a bed, with the body part under examination placed in the round tunnel or opening of the scanner. The bed then moves slowly backwards and forwards to allow the scanner to take pictures of the body, although it doesn't touch the patient. The length of the test depends on the number of pictures and the different angles taken.

The timing, anode voltage (kV) and beam current (mA) are controlled by a computer through a control bus. The high volt DC power supplies drive an x-ray tube that can be mechanically.

### APPLICATIONS:

- Central Nervous systems, Orthopedics and bione tumors, thorax.
- Abdomen, Pelvis and neck.
- Radiotherapy planning.

### 9.3. (B) ULTRASOUND

Ultrasound is cyclic sound pressure with a frequency greater than the upper limit of human hearing. Although this limit varies from person to person, it is approximately 20 kilohertz (20,000 hertz) in healthy, young adults and thus, 20 kHz serves as a useful lower limit in describing ultrasound. The production of ultrasound is used in many different fields, typically to penetrate a medium and measure the reflection signature or supply focused energy. The reflection signature can reveal details about the inner structure of the medium, a property also used by animals such as bats for hunting. The most well known application of ultrasound is its use in sonography to produce pictures of fetuses in the human womb. There are a vast number of other applications as well.

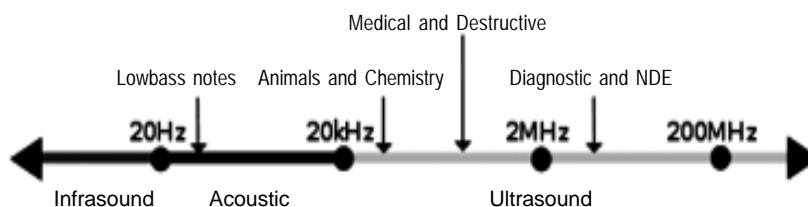

Fig. 9.2 (a) Ultrasound Frequency range

Approximate frequency ranges corresponding to ultrasound, with rough guide of some applications



Fig. 9.2 (b) A fetus in its mother's womb, viewed in a sonogram (brightness scan)



Fig. 9.2 (c) An ultrasound examination in East Germany, 1990

#### **9.4 ELECTRONIC BP APPARATUS**

A manually operated monitor that consists of a cuff, bulb, and dial gauge to register blood pressure levels. The only way for us to know if we have normal or abnormal conditions is by measuring them. These can be done through an ideal apparatus. They are available in four types: Semi Automatic, Fully Automatic, Wrist Type and fully automatic memory. These machines measure blood pressure correctly on the upper arm at heart level. The readings are given on a digital display and can be stored in the monitor's memory or in a printed format.

#### **9.5 DIGITAL THERMOMETERS**

Thermistor digitals generally have “built in” probes and sensors. They must be calibrated during the manufacturing process and so are not interchangeable. Thermocouple digitals, with some exceptions, can accept any matching category of probe (the two most common are K-type and T-type—these have different temperature ranges). We concentrate on K-type only, since this type spans all food application temperatures, and has more availability of probe options.

Accuracy can be very good with both types, but thermistor digitals are limited to the type of built-in probe they come with, and if the probe breaks, you have to buy a new thermometer.

Thermocouple digital thermometers are generally very predictable in their quality, and the response characteristics of their fitted probes is within a very narrow range. All QA stocks the highest quality thermocouple digital thermometers, so they can be used with high confidence.

Thermistor digitals are made worldwide, and can have variable quality, if not carefully checked. All QA performs checks of all of their thermistor-based products to ensure that their customers are getting products of excellent quality.

#### **9.6 ELECTROENCEPHALOGRAPHY**

EEG is a superposition of the volume-conductor fields produced by a variety of active neuronal current generators. The three type of electrodes to make the measurements are scalp, cortical, and depth.



Fig. 9.3 Electroencephalography

**Bioelectric Potential From the Brain**

Wave group of the normal cortex

**ALPHA WAVE**

- 8 to 13 Hz, 20-200  $\mu$ V,
- Recorded mainly at the occipital region
- disappear when subject is sleep, change when subject change focus, see Fig. 4.27b

**BETA WAVE (I AND II)**

- 14 to 30Hz,
- during mental activity  $f=50$ Hz, beta I disappear during brain activity while beta II intensified.
- Recorded mainly at the parietal and frontal regions

**THETA WAVE**

4 to 7 Hz, appear during emotional stress such as disappointment and frustration  
Recorded at the parietal and temporal regions

**DELTA WAVE**

Below 3.5 Hz, occur in deep sleep, occur independent of activity

Occur solely within the cortex, independent of activities in lower regions of the brain.

Synchronization is the underline process that bring a group of neurons into unified action. Synaptic interconnection and extra cellular field interaction cause Synchronization.

**EEG WAVES**

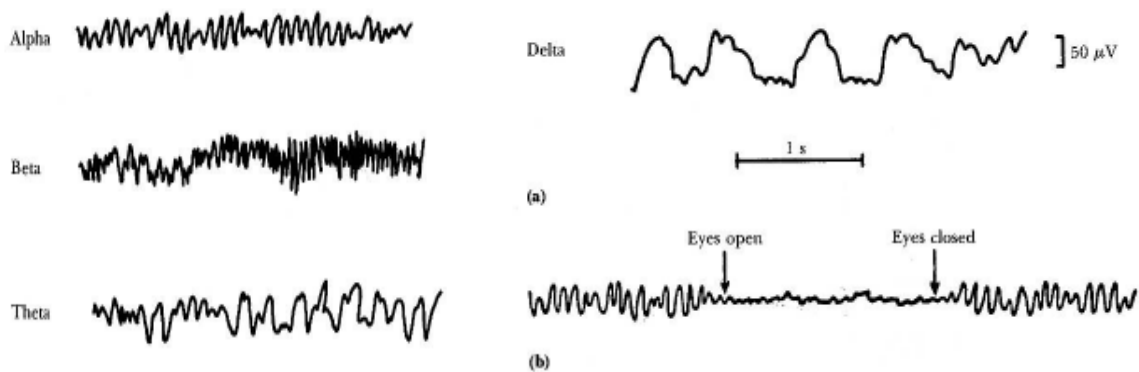

## EEG WAVES DURING SLEEP

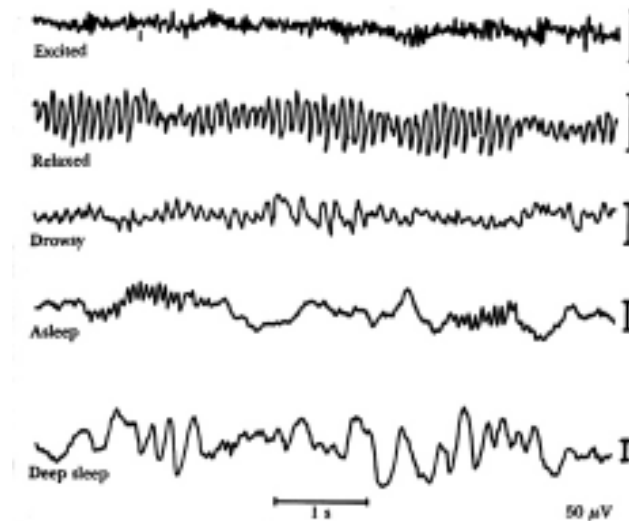

## THE ABNORMAL EEG

EEG is used to diagnose different type of epilepsy and in the location of the focus in the brain causing the epilepsy. Causes of epilepsy could be intrinsic hyper excitability of the neurons that make up the reticular activation system (RAS) or by abnormality of the local neural pathways of this system.

Two type of epilepsy

1- Generalized epilepsy

a- Grand mal

b- petit mal (myoclonic form and absence form)

2- Partial epilepsy

a- Jacksonian epilepsy

b- Psychomotor seizure (amnesia, abnormal rage, sudden anxiety or fear, incoherent speech)

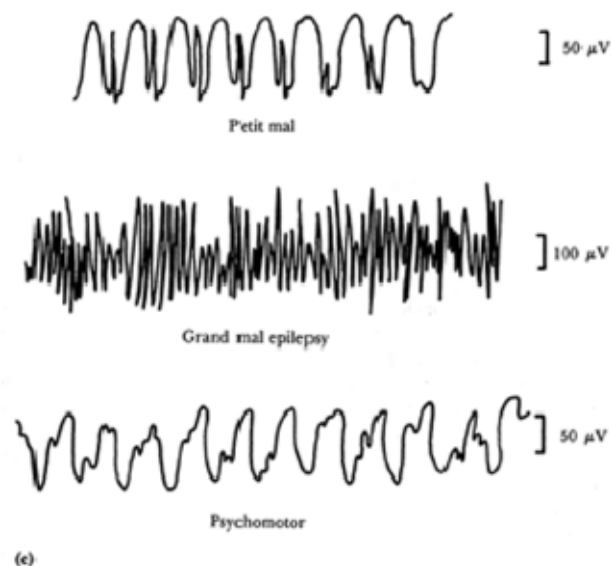

Fig. Types of epilepsy

## 9.7 DIGITAL X-RAY

### PARTS OF A DIGITAL X-RAY MACHINE:

The digital X-Ray machine consists of an X-Ray tube and driver to source X-Ray. The X-Ray passes through the patient's body and the digital camera (located on the other side of the patient) captures the resulting image. The main base station controls the X-Ray tube, analyzes the image and displays the image on the CRT.

### DIGITAL CAMERA:

The digital camera converts the received image into digital signal and transfers the digitized image to the base station through a fiber optic link.

#### Main Base Station

The functions of the main base station are as follows:

- Drive and control the X-Ray tube
- Communicate with the digital camera system through Fiber
- Store the pictures on the hard disk for image retrieval and processing
- Interface to an operator console for overall system control and image manipulation
- Analyze and enhance the image stored on the hard disk and display the enhanced X-Ray image on a CRT monitor

- **Key to Lattice Solutions**

- |           |        |      |      |               |
|-----------|--------|------|------|---------------|
| LatticeSc | ispPAC | FPGA | CPLD | Power Manager |
|-----------|--------|------|------|---------------|

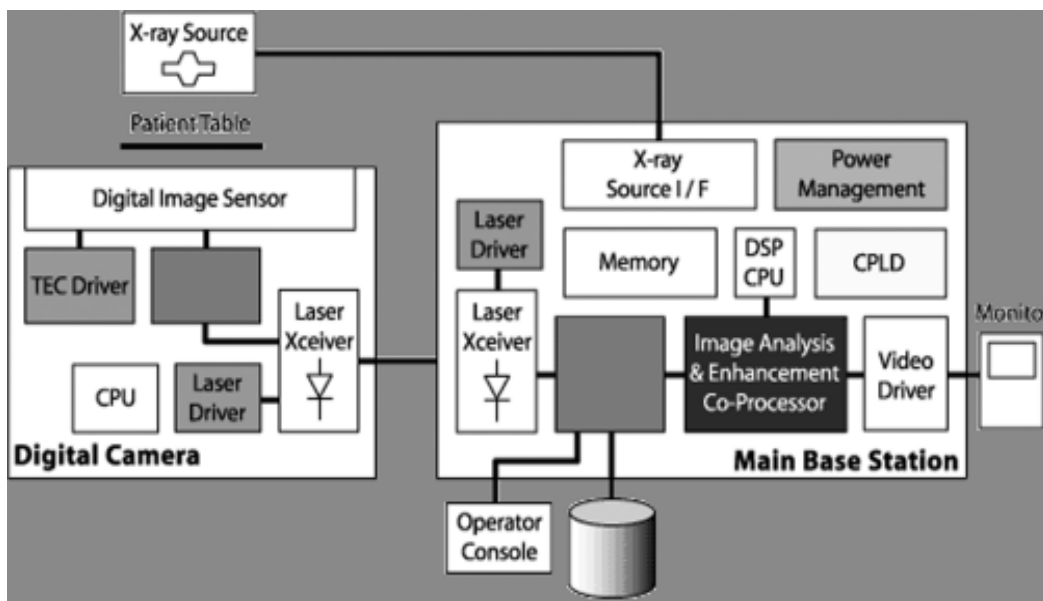

Fig. 9.4. Block Diagram of Digital X-ray

### DEVICES USED

- LatticeSC or ORT42G5
- FPGA
- Power Manager
- ispPAC
- CPLD



## **FUNCTIONS PERFORMED**

- Digital interface to CCD
- Direct interface to Laser module

## **LATTICE SC**

### **LATTICE ADVANTAGES**

- Reduced Board Space
- CML interfaces directly to most Laser Modules
- Reduced time to market
- High performance SERDES for increased system reliability

## **Isp PAC**

### **FUNCTIONS PERFORMED**

- Maintain the temperature of the CCD detector
- Automatic Laser power control
- Laser diode end-of-life flag

### **LATTICE ADVANTAGES**

- Quiet operation through Analog feedback control loop
- Digital Temperature setting
- Easy interface to H-Bridge
- Compensate for Laser - Diode to Diode parametric variation
- Quiet operation due to Analog feedback control

## **FPGA**

### **FUNCTIONS PERFORMED**

- Customizable DSP FIR and IIR Filter
- Interface to ADC
- Glue Logic: FIFO, Memory Interface, etc.

### **LATTICE ADVANTAGES**

- Easy customization of Algorithm
- High speed FPGA fabric for various glue logic
- High speed buffer management
- Multiple high performance MAC (Multiply & Accumulate primitive)
- Increase DSP throughput
- On-Chip PLL for timing control and pipelining

## **CPLD**

### **FUNCTIONS PERFORMED**

- CPU bus interface state machines
- Multi-port memory interface for ORT42G5, Co-processor FPGA, and CPU
- SDRAM interface

### **LATTICE ADVANTAGES**

- Improves performance of DSP CPU operation without wait states

- Multi-port SDRAM drive without performance degradation
- FIFO for mixing and matching the processing and data transfer rates

## **FUNCTIONS PERFORMED**

- Implements all the power supply management for that Port Card

## **LATTICE ADVANTAGES**

- Reduced board space
- Increased reliability
- Reduced time to market

## **9.8. NANOTECHNOLOGY AND ITS APPLICATIONS**

Nanotechnology, shortened to “nanotech”, is the study of the controlling of matter on an atomic and molecular scale. Generally nanotechnology deals with structures sized between 1 to 100 nanometer in at least one dimension, and involves developing materials or devices within that size. Nanotechnology is very diverse, ranging from extensions of conventional device physics to completely new approaches based upon molecular self-assembly, from developing new materials with dimensions on the nanoscale to investigating whether we can directly control matter on the atomic scale.

There has been much debate on the future implications of nanotechnology. Nanotechnology may be able to create many new materials and devices with a vast range of applications, such as in medicine, electronics, biomaterials and energy production. On the other hand, nanotechnology raises many of the same issues as with any introduction of new technology, including concerns about the toxicity and environmental impact of nanomaterials, and their potential effects on global economics, as well as speculation about various doomsday scenarios. These concerns have led to a debate among advocacy groups and governments on whether special regulation of nanotechnology is warranted.

Buckminsterfullerene C<sub>60</sub>, also known as the buckyball, is a representative member of the carbon structures known as fullerenes. Members of the fullerene family are a major subject of research falling under the nanotechnology umbrella.

The first use of the concepts found in ‘nano-technology’ (but pre-dating use of that name) was in “There’s Plenty of Room at the Bottom”, a talk given by physicist Richard Feynman at an American Physical Society meeting at Caltech on December 29, 1959.

## **FUNDAMENTAL CONCEPTS**

One nanometer (nm) is one billionth, or  $10^{-9}$ , of a meter. By comparison, typical carbon-carbon bond lengths, or the spacing between these atoms in a molecule, are in the range 0.12–0.15 nm. On the other hand, the smallest cellular life-forms, are around 200 nm in length.

To put that scale in another context, the comparative size of a nanometer to a meter is the same as that of a marble to the size of the earth. Two main approaches are used in nanotechnology. In the “bottom-up” approach, materials and devices are built from molecular components which assemble themselves chemically by principles of molecular recognition. In the “top-down” approach, nano-objects are constructed from larger entities without atomic-level control.

Image of reconstruction on a clean Gold(100) surface, as visualized using scanning tunneling microscopy. The positions of the individual atoms composing the surface are visible.

A number of physical phenomena become pronounced as the size of the system decreases. These include statistical mechanical effects, as well as quantum mechanical effects, for example the “quantum size effect”.

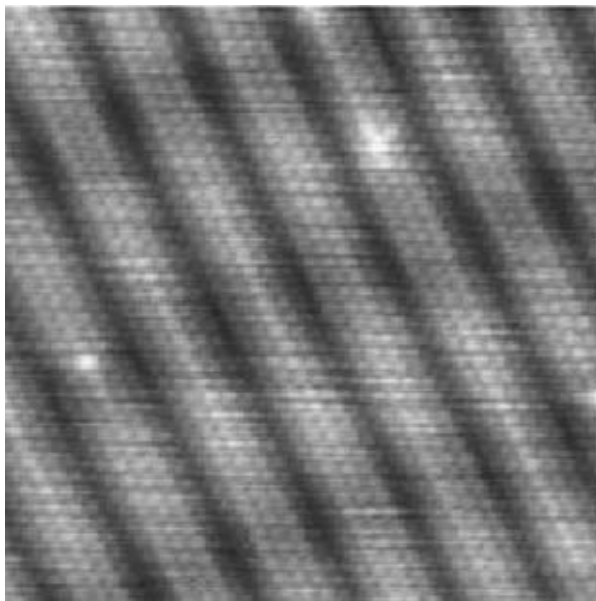

Fig. 9.6 Image of reconstruction on a clean Gold(100) surface

Materials reduced to the nanoscale can show different properties compared to what they exhibit on a macroscale, enabling unique applications. For instance, opaque substances become transparent (copper); stable materials turn combustible (aluminum); insoluble materials become soluble (gold). A material such as gold.

Modern synthetic chemistry has reached the point where it is possible to prepare small molecules to almost any structure. These methods are used today to manufacture a wide variety of useful chemicals such as pharmaceuticals or commercial polymers.

### **MOLECULAR NANOTECHNOLOGY: A LONG-TERM VIEW**

Molecular nanotechnology, sometimes called molecular manufacturing, describes engineered nanosystems (nanoscale machines) operating on the molecular scale. Molecular nanotechnology is especially associated with the molecular assembler, a machine that can produce a desired structure or device atom-by-atom using the principles of mechanosynthesis. Manufacturing in the context of productive nanosystems is not related to, and should be clearly distinguished from, the conventional technologies used to manufacture nanomaterials such as carbon nanotubes and nanoparticles.

### **APPLICATIONS**

Mostly applications are limited to the use of “first generation” passive nanomaterials which includes titanium dioxide in sunscreen, cosmetics and some food products; Carbon allotropes used to produce gecko tape; silver in food packaging, clothing, disinfectants and household appliances; zinc oxide in sunscreens and cosmetics, surface coatings, paints and outdoor furniture varnishes; and cerium oxide as a fuel catalyst.

One of the major application of nanotechnology is in the area of nanoelectronics with MOSFET's being made of small nanowires ~10 nm in length. Here is a simulation of such a nanowire.

Some of the recently developed nanoparticle products may have unintended consequences. Researchers have discovered that silver nanoparticles used in socks only to reduce foot odor are being released in the wash with possible negative consequences. Silver nanoparticles, which are bacteriostatic, may then destroy beneficial bacteria which are important for breaking down organic matter in waste treatment plants or farms.

## QUESTIONS

### I. CHOOSE THE BEST ANSWERS

1. A device which is used to diagonalise the image \_\_\_\_\_  
 A) CT Scan                      B) Infusion pipes                      C) Lungs machine                      D) ECMO
2. Within the home we could control \_\_\_\_\_ using electronic medical equipment.  
 A) Heart disorder                      B) Mellitus                      C) Cancer                      D) Epilepsy
3. \_\_\_\_\_ is an equipment used to convert the heart beat into an electrical signal.  
 A) Digital x-ray                      B) Electronic thermometer  
 C) Electronic BP apparatus                      D) ECG
4. The low frequency of \_\_\_\_\_ ultra sound limit can be heard by normal man.  
 A) 20 Hz                      B) 2 kHz                      C) 20kHz                      D) 200 kHz
5. Ultrasound is mainly used in \_\_\_\_\_  
 A) Sonography                      B) Physiotherapy                      C) Blood Pressure                      D) Heart Disorder
6. An electronic BP apparatus has \_\_\_\_\_ shaped meter.  
 A) Square                      B) Rectangle                      C) Dial                      D) Ellipse
7. EEG is used to convert \_\_\_\_\_ activity into electrical waves.  
 A) Heart                      B) Lungs                      C) Brain                      D) Neuronal
8. Theta waves have \_\_\_\_\_ wave range.  
 A) 4 to 30 Hz                      B) 4 to 7 Hz                      C) 8 to 13 Hz                      D) 3 to 3.5 Hz
9. Nano technology has designed to \_\_\_\_\_ sized nanoparameter materials.  
 A) 1-100                      B) 10-100                      C) 1-10                      D) 100-1000
10. Recently developed nanotechnology used to change the opaque material into transparent.  
 A) Zinc                      B) Copper                      C) Aluminium                      D) Gold

### II. ANSWER IN FEW WORDS

1. Say any one of the diagonalize equipment.
2. Who invented the endoscopes device and when?
3. Expand-ECG
4. What are the two kinds of digital thermometer?
5. Where are images stored in CT Scan?
6. Who talk first about the use of nanotechnology?

### III. ANSWER IN FEW WORDS:

1. Name few electronic medical equipments.
2. What are uses of CT Scan?
3. What is the work of EEG?
4. Write the different kinds of waves used in EEG.

5. Write about the structure of digital x-ray.
6. What is meant by nanotechnology.

#### **IV. EXPLAIN IN DETAIL ABOUT ONE PAGE**

1. How is the ECG machine works?
2. Write about the operation of CT Scan.
3. Explain the ultra-sound.
4. How does EEG operates.
5. What are the uses of digital x-ray?

#### **V. EXPLAIN BRIEFLY ABOUT TWO PAGES**

1. Explain the term nanotechnology and its uses.
2. Explain any four electronic medical equipments.

**ANS :** 1) a   2) b   3) d   4) c   5) d   6) a   7) c   8) d   9) b   10) b

# MODEL QUESTION PAPER ELECTRONIC EQUIPMENTS

Time: 3 Hours

Marks: 200

## PART – A

### ANSWER ALL QUESTIONS

#### 1. CHOOSE THE CORRECT ANSWERS:

15x1=15

1. An ..... is a logical circuit that performs an addition operation on three-one bit binary numbers.  
a) Half adder                      b) Full adder                      c) Invertor                      d) subtractor
2. In frequency modulation carrier waves are various in accordance with ..... of the signal wave.  
a) Frequency                      b) Phase                      c) width                      d) Amplitude
3. The simplest radio receiver is the .....  
a) Crystal                                              b) AM receiver  
c) FM receiver                                              d) Communication receiver
4. No sound is heard in a radio receiver in on condition, it is said to be .....  
a) Live fault                      b) intermittent fault                      c) Dead fault                      d) Low sound fault
5. The electron ray moving from left to right and right to left is called as .....  
a) Horizontal Scanning                                              b) Vertical Scanning  
c) Interlaced Scanning                                              d) Sequential Scanning
6. Video band width in CCIR – PAL System is .....  
a) 10MHZ                      b) 15 MHZ                      c) 25 MHZ                      d) 5 MHZ
7. In colour television picture tube there are ..... electron guns are used.  
a) 5                      b) 2                      c) 3                      d) 1
8. Tape recorder ribbon is made up of .....  
a) Iron                      b) Iron & Zinc                      c) Zinc                      d) Aluminium
9. Cell Phone receiver register the voice and convert it into .....  
a) Current wave                      b) Radio wave                      c) Light wave                      d) Audio wave
10. Infra red rays means .....  
a) Light rays                                              b) Electromagnetic waves  
c) Radio waves                                              d) Sound waves
11. Computers has the power of .....any amount of information (or) data.  
a) Controlling                      b) Stopping                      c) Storing                      d) Erasing
12. The ALU and CU of the computer system are jointly known as .....  
a) Arithmetic and logical unit                                              b) Control unit  
c) Central Processing Unit                                              d) Storage unit

13. A radar system has a transmitter that units .....
- a) Radio wave            b) Audio wave            c) Micro wave            d) Modulated waves
14. Recently develop nano-technology used to change the .....opaque material into transparent.
- a) Zinc                      b) Copper                      c)Aluminium                      d) Gold
15. Satellite cell phone is shortly name as .....
- a) Sat-phone            b) Cell phone            c) Mobile phone            d) Walkie-talkie

**II. ANSWER ALL QUESTIONS IN ONE OR TWO WORDS**

**15x1=15**

16. Name three types of multivibrators.
17. Which antenna is mounted on the earth surface?
18. Who built antenna first?
19. What is image frequency?
20. What is meant by pre-amplifier?
21. What type of cathode is used in picture tube?
22. What is Acquadac-coating?
23. How the speed of record player is changed?
24. How many minimum no. of speakers are used in home theater?
25. Which system is used in 2G cell phones.
26. Expand \_ CPU , ALU
27. Give two examples of Full-duplex.
28. Name two input devices in computer.
29. What is meant by radior?
30. Say any one of the diagonalize equipment?

**PART-B**

**III. ANSWER ANY 10 QUESTION IN ONE OR TWO LINES**

**10x4=40**

31. Define AND Gate
32. Define Full-adder
33. What are the kinds of modulation?
34. What are the principles followed in a radio receivers generally?
35. What are the kinds of FM detectors?
36. Define Kell-factor
37. What are parts in a CD?
38. What are the different kinds of i-pod?
39. What are main functions of Storage Unit?
40. Name any three types of printers?

41. What are the functions of communication satellite?
42. What is meant by nanotechnology?

### **PART-C**

**IV. ANSWER ANY FIVE OF THE FOLLOWING. BUT THE QUESTION NO-49 IS COMPULSORY. 5x10=50**

43. Explain Astable multivibrator.
44. Write about Yagi antenna?
45. Draw and Explain the functions of R.P. amplifier?
46. How can the USB used in data media.
47. Explain: (1). CPU and (2) ALU
48. Explain about communication satellites.
49. Draw a neat sketch of picture tube and name its parts.

(or)

Explain about : (1) ECG (2) Ultra-sound

### **PART-D**

**V. ANSWER BRIEFLY ANY FOUR QUESTIONS ABOUT TWO PAGES. QUESTION NO.55 IS COMPULSORY 4x20=80**

50. Write short notes on given below.  
(1) Half adder (2) Full adder (3) Half subtractor (4) Full subtracter (5) Flip –flop
51. Draw and Explain the block diagram of FM radio receiver?
52. Draw the block diagram of TV receiver with wave forms
53. List out the probable causes for dead fault in a TV receiver in sequential order.
54. Give details about cell-phone frequency.
55. Explain the input and out devices of computers.

(or)

Draw the block diagram of communication receiver and explain.



# **Electronic Equipments**

## **Practical - I & II**

**Vocational Education**  
**HIGHER SECONDARY - SECOND YEAR**

A Publication under  
Government of Tamilnadu  
Distribution of Free Textbook Programme  
(Not For Sale)

**Untouchability is a sin**  
**Untouchability is a crime**  
**Untouchability is inhuman**



**TAMILNADU**  
**TEXTBOOK CORPORATION**  
**College Road, Chennai - 600 006.**

## **CHAIR PERSON**

**Dr.R.S.D. Wahida Banu**

Professor and Head,  
Department of Electronics & Communication Engineering,  
Government College of Engineering,  
Salem - 636 011.

## **AUTHORS**

**Dr. M. Chandrasekar**

Associate Professor,  
Department of Electronics &  
Communication Engineering,  
Government College of Engineering,  
Salem - 636 011.

**Miss. S. Salma Mehajaben**

Lecturer,  
Department of Electronics &  
Communication Engineering,  
Government College of Engineering,  
Salem - 636 011.

**Mr. C.Amirdalingam**

Vocational Teacher,  
Govt.Hr.Sec.School,  
Yethapur- 636 117  
Salem District.

**Mrs. G.Umamaheswari**

Vocational Teacher,  
Govt.Hr.Sec.School,  
Mettupatty- 636 111  
Salem District.

This book has been prepared by the Directorate of School Education  
on behalf of the Government of Tamilnadu

This Book has been printed on 60 GSM Paper

Printed by web offset at :

## **PRACTICAL - I**

Experiment No : 1	Study of RF signal Generator and CRO.
Experiment No : 2	Construction and Testing of Multivibrators using Ic 555.
Experiment No : 3	Study and Verification of Logic Gates.
Experiment No : 4	Construction and testing of half adder full adder and flip-flops.
Experiment No : 5	erection and testing of dish antenna.
EXperiment No : 6	Construction of audio Amplifier using TBA 810 IC.
Experiment No : 7	Construction and testing of Encoders and Decoders.
Experiment No : 8	Connect and measure the voltages of various stages in AM Radio Receiver.
Experiment No : 9	Assemble A FM radio receiver and determine its potential at various stages.
Experiment No : 10	Trouble shoot and rectify the fault in AM receiver.
Experiment No : 11	Find the fault in FM radio receiver and repair it.
Experiment No : 12	Construction of FM radio using CAX 1619 and TBA 810 IC And operate it.
Experiment No : 13	Rectify the weak sound (low volume) in AM radio receiver.
Experiment No : 14	Identify the fault occured in AM radio receiver - Hum Sound and rectified it.
Experiment No : 15	Rectify the fault in fm receiver - noisy reception.

## PRACTICAL - II

- Experiment No: 1 Study of pattern generator and function generator (with counts).
- Experiment No : 2 Rectification of the fault and operation of a TV Receiver (Dead Fault).
- Experiment No : 3 Rectification of Snow Picture fault and operation of a TV Receiver.
- Experiment No : 4 Rectification of No Colour fault and operation of a TV Receiver.
- Experiment No : 5 Rectification of Red Retrace line Fault and operation of a colour TV Receiver.
- Experiment No : 6 Rectification of Green Retrace lines fault and operation of a Colour TV.
- Experiment No : 7 Rectification of Blue retrace lines fault and operation of a colour TV.
- Experiment No : 8 Rectification of Horizontal line fault and operation of a TV.
- Experiment No : 9 Rectification of Vertical line fault and operation of a TV
- Experiment No : 10 Rectification of Height less Picture fault and operation of a TV .
- Experiment No : 11 Rectification of No Sound with Normal picture fault and operation of a TV .
- Experiment No : 12 Rectification of Retrace lines fault and operation of a TV .
- Experiment No : 13 Find and rectify the dead fault in dvd player.
- Experiment No : 14 Identify and rectify No Disc fault In the DVD - player .
- Experiment No : 15 Study of cell phone and its maintenance.
- Experiment No : 16 Study of TV and DVD Remote and its Maintenance.
- Experiment No : 17 Study of SMPS.

# PRACTICAL - I

## EXPERIMENT NO - 1

### STUDY OF RF SIGNAL GENERATOR AND CRO

#### Aim

To study the basic operations of a RF signal generator and a CRO.

#### Components required

S.no	Name of Component/Apparatus	Quantity
1.	RF signal generator	1
2.	CRO 20 MHz	1

#### 1.Signal Generator Working Principle

It is an electronic equipment which is used to generate Audio Frequency and Radio Frequency waves. Signal generator generates 150KHz to 30MHz radio frequency and 400Hz audio frequency, and also it modulates the waves that transmits to about 100kms.



Fig.1 (a) : Signal Generator Front panel

## 2. Front Panel of Signal Generator

1. **ON - OFF Switch** : It is used to activate (ON - OFF) the generator.
2. **Mode Selector** : It is a control switch, which is used to select three types of waves, they are i) Carrier wave (ii) Modulated wave (iii) AF waves are obtained in the o/p.
3. **Band Selector** : It is used to select the bands in the scale. It is also known as Range selector. It is used in radio receiver to select the various bands.
4. **Frequency Selector** : It is used to select the required particular frequencies. In the front panel the frequency ranges A, B, C, D, E, G are given in KHz and MHz ranges tuning the selector the particular frequency is obtained.
5. **Gain Control** : It is used to control the gain of RF & AF waves. It is a variable resistor i.e., potentiometer.
6. **Output** : The wave which is selected from the mode Selector is obtained in the o/p. It is connected through a cable to the radio receivers and RF, AF, IF wave ranges are verified.

## 3. Uses of signal Generator

1. It is used to transmit the small ranges of waves. It is also called as AM Transmitter.
2. It is used to correct the RF, IF, AF wave ranges in the Radio Receiver and used to get the noise less sound.

## CRO - (Cathode Ray Oscilloscope)

It is used to generate the waveforms for various frequencies of the O/P circuit.

### 1. Structure of CRO

It has three important parts.

**Electron Gun** : It consist of a filament and cathode, Cathode is heated by the filament, and electrons are emitted from the cathode.

### 2. Neck Part : It has three grids and two sets of movable discs x and y.

- (i) **First grid** : It is used to control the electron beam which is generated by the cathode.
- (ii) **Second grid** : It accelerates the electron beam.
- (iii) **Third grid** : It takes the electron rays to the centre of the screen.
- (iv) **Moving Plates** : It is called as x, y plates. Electron beam can be oscillated by giving voltages. This process is called electrostatic deflection.
  - (a). **X- Plates** : It is connected to the time base circuit and generates the saw tooth waveform. It is used to move the beam from centre to Horizontal direction. It is a X-axis in the display.
  - (b). **Y- Plates** : It is connected to the outer circuit of the the vertical deflection. It is used to move the beam from centre to the vertical direction. It is a y- axis in the display.

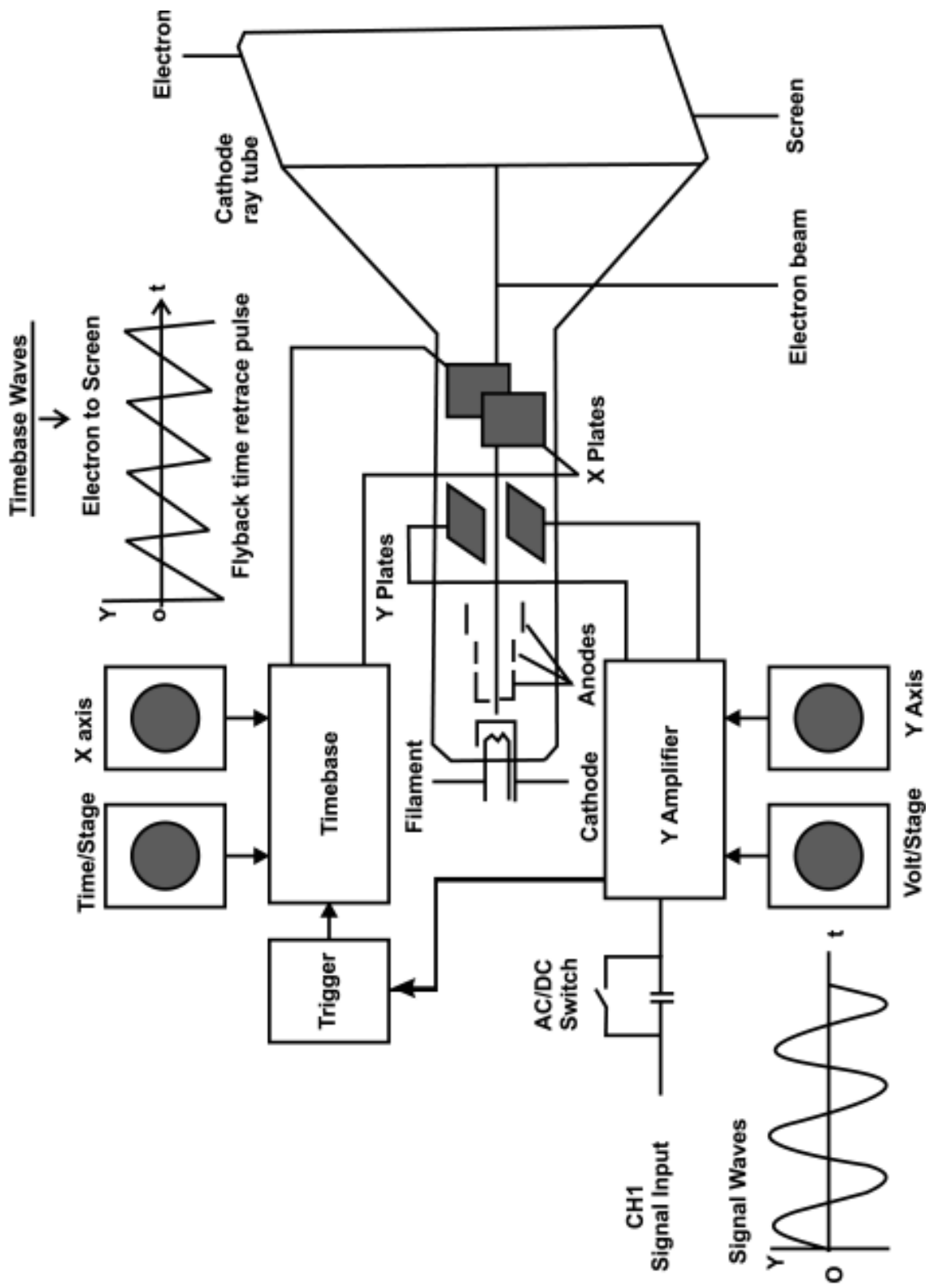
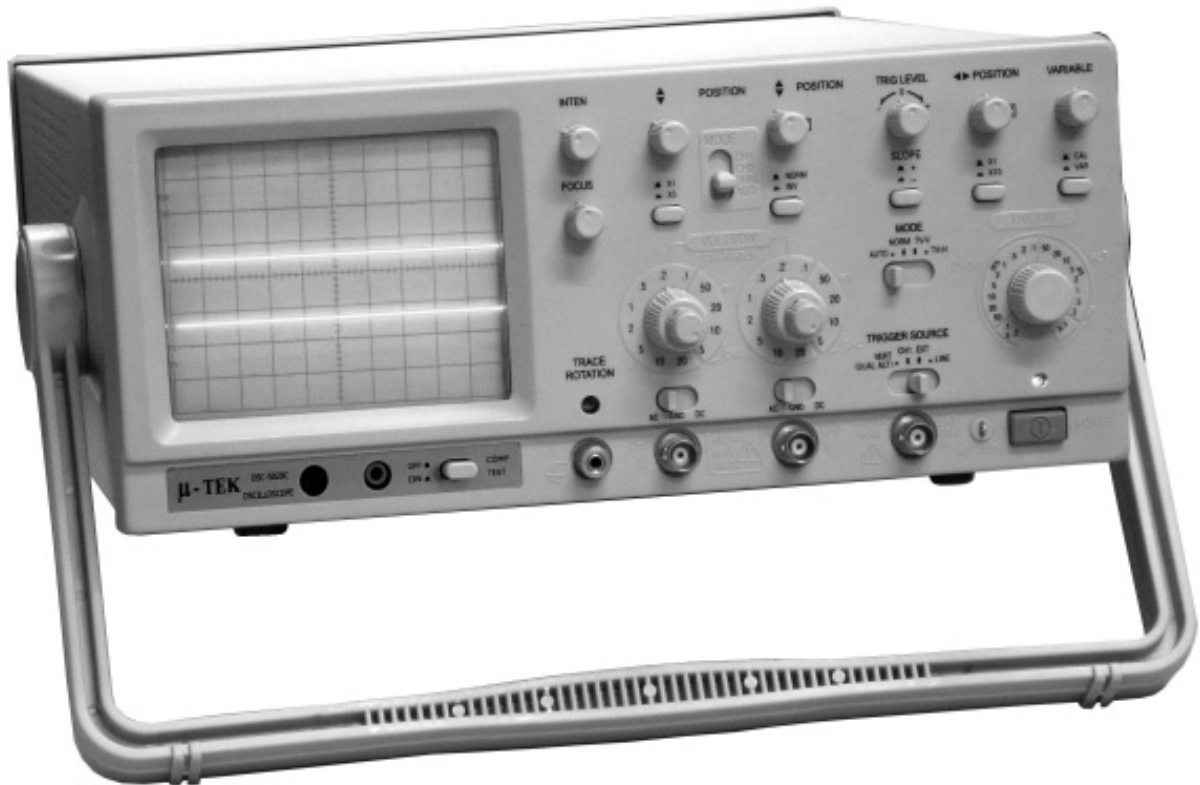

Fig.1 (b) : Block Diagram of CRO



**Fig.1 (c) : Front Panel of CRO**

3. **Screen** : CRO has a screen. It is a vacuum tube which is like a picture tube in television.

  1. **AC/DC Switch** : Inputs are given at the OFF position. Amplified waves are given to the Y-plate.
  2. **Volts / Div** : Using this controlling button, change the size of the waveform as low or high.
  3. **Trigger Circuit** : The wave displayed on the screen keeps on oscillating. So using time delay circuit and keep the wave form stable. So that amplitude, frequency and phase are measured.



#### 4. USES OF CRO

1. It is used to see time varying waveforms
2. We can align all blocks in the TV receiver
3. It is used to measure signal voltage
4. To measure signal frequency
5. We can find out the faults in DVD, VCD, VCP using CRO.

#### FRONT PANEL CONTROL OF CRO

1. **ON - OFF** : The ON-OFF switch control used to operate the CRO in ON-OFF position.
2. **INTENSITY** : This knob controls the intensity or brightness of the light produced by beam spot. It actually controls the number of electrons per second that are bombarding the screen. The potentiometer which is connected to the control grid voltage varies the intensity.
3. **FOCUS** : This controls the sharp of the spot. This is obtained by varying the voltage applied to the focussing anodes.
4. **SCREEN** : It is a some sort of plastic screen in front of the cathode ray tube. This screen has engraved like graph paper. This is called graticule this scale facilitates the measurements of the oscilloscope.
5. **V. POSITION** : With the help of this control the pattern obtained on the screen can be shifted a whole to vertically upward and downward. This is achieved by adding DC voltages to input signals.
6. **H. POSITION** : This is used to shift the display as a whole to left or right.
7. **VET - SET - ATTENUATOR** : This makes the gain of the vertical amplifier 10 times greater than normal.
8. **GROUND** : The input of the amplifier is grounded. There will be no vertical deflection. It is used for measuring voltage with respect to ground.
9. **SYNC LEVEL** : To obtain the standard pattern on the screen. There are various signals which can be applied to the trigger circuit. The signals can be selected using a sync selector switch. 1. Internal 2. Line 3. External.
10. **SWEEP SELECTOR** : The horizontal amplifier receives an input from saw tooth sweep generator which is triggered by sync. Amplifier.

#### RESULT

Thus the basic operation of a signal generator and CRO were studied.

## EXPERIMENT NO - 2

### CONSTRUCTION AND TESTING OF MULTIVIBRATORS USING IC 555

#### AIM

To test the multivibrators using IC 555.

#### COMPONENTS REQUIRED

S. No	Name of Component/Apparatus	Range	Quantity
1.	IC 555		1
2.	Resistance	1k $\Omega$ , 5k $\Omega$ , 100k $\Omega$	2 3 1
3.	Capacitor	0.01 $\mu$ F	2
4.	Transistor	NPN	2
5.	Bread Board	-	1
6.	CRO with Probe	-	1

#### ASTABLE MULTIVIBRATORS

This type of Multivibrators generate different types of wave forms. Using IC 555 the circuit is assembled. It has no stable output. That is variation of output takes place accordingly. So we get a square wave forms. We can find the output and voltage range of the capacitor using the table.

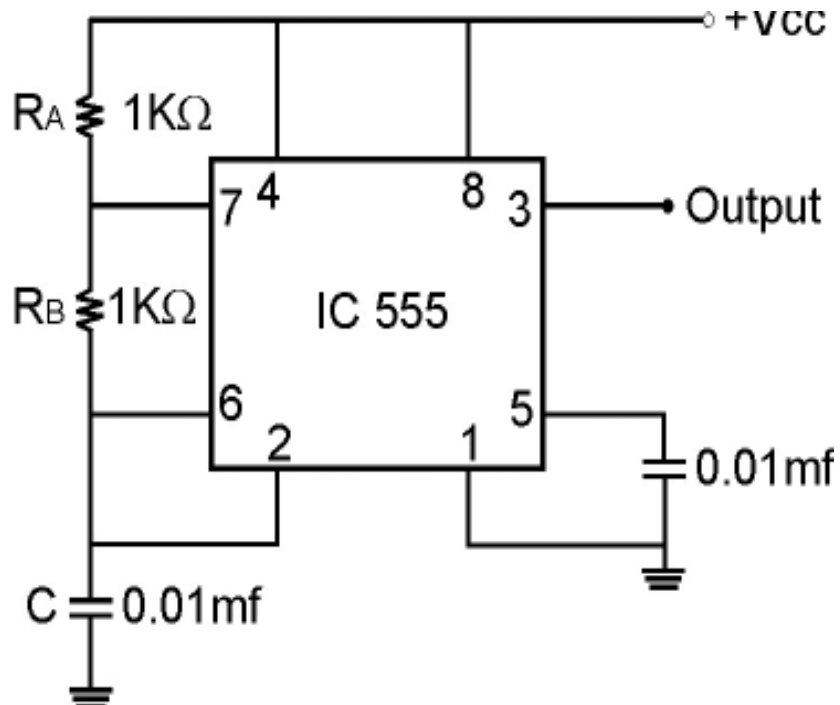

Fig. 2 (a) : Astable Multivibrator

## CALCULATIONS

- The charging time of the capacitor is given by  

$$T_c = \text{Charging time} = 0.693 (R_A + R_B) C \text{ ms}$$
- While discharging time is given by,  

$$T_d = \text{Discharging time} = 0.693 (R_B) C \text{ ms}$$
- Hence the Total time for one cycle.  

$$T = T_c + T_d$$

$$= 0.693 (R_A + R_B) C + 0.693 (R_B) C \text{ ms}$$

$$= 0.693 (R_A + 2R_B) C$$
- The Frequency of oscillators is given by  

$$F = 1/T = \frac{1}{0.693(R_A + 2R_B)C} \text{ OR } \frac{1.44}{(R_A + 2R_B)C} \text{ KHz}$$

## ASTABLE MULTIVIBRATOR

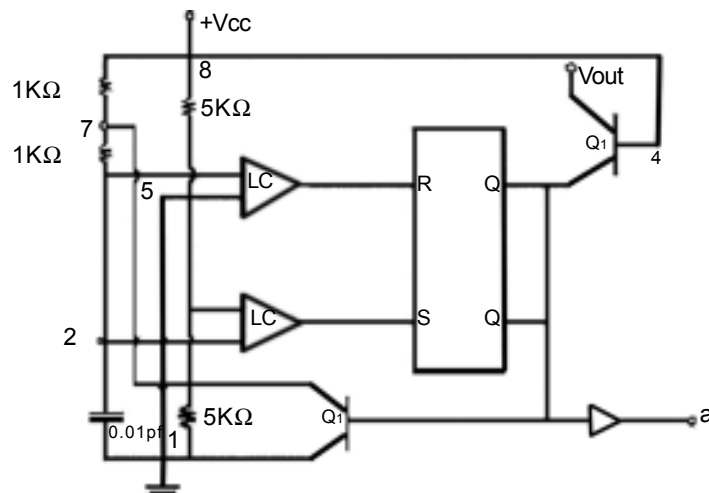

Fig. 2 (b) : Astable Multivibrator

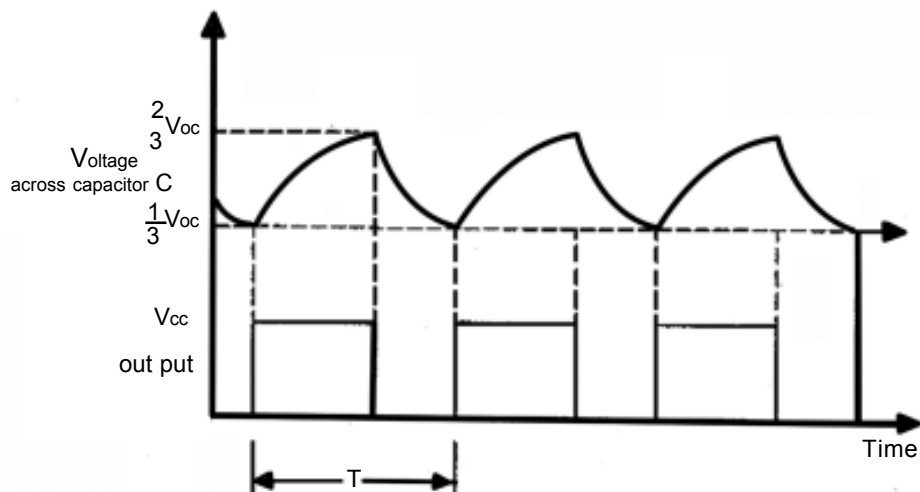

Fig. 2 (c) : Output Wave form



- At first it has low level output. When trigger is applied, it produces high level output and returns back to stable stage.
- The graph shows the waveform of the monostable multivibrator.

### CALCULATION

Time of high level O/P.

$$T = 1.1 (R \times C) \text{ Seconds}$$

R in Ohms and C in farads.

### RESULT

Thus the given astable and monostable multivibrators tested by using IC 555.

### EXPERIMENT NO - 3

## STUDY AND VERIFICATION OF LOGIC GATES

### Aim

To study two inputs basic gates such as NOR, NAND, EX-OR, using TTL and IC and verify the truth tables.

### Components Required

S.no.	Name of Components/Apparatus	Quantity
1.	DC regulated Power supply (0-5V)	1
2.	NOR Gate 7402	1
3.	NAND Gate 7400	1
4.	EXOR Gate 7486	1
5.	LED	10
6.	Bread board	1

### Procedure

- Fit the IC on the bread board
- Switch on the power supply.
- Inputs are given to the IC Input pins as per the schematic diagram and outputs are observed and tabulated for various logic gates.
- 5V DC is set as 1 and 0 volt is 0. The inputs are mentioned as A and B.
- Switch off the supply and remove the connections

### 1.NOR GATE

It is a combination of NOT and OR gate and the operation of NOR gate is inverse of the OR gate.

- Boolean equation for NOR gate is  $Y = A+B$
- If both the inputs of A or B = 0 then the O/P of Y = 1.
- We can verify the operation by the truth tables and also by glowing of LED.
- If the I/p is low then the o/p will be high.
- Operation of the NOR gate is verified from the truth table.

**NOR**

**LOGIC SYMBOL**

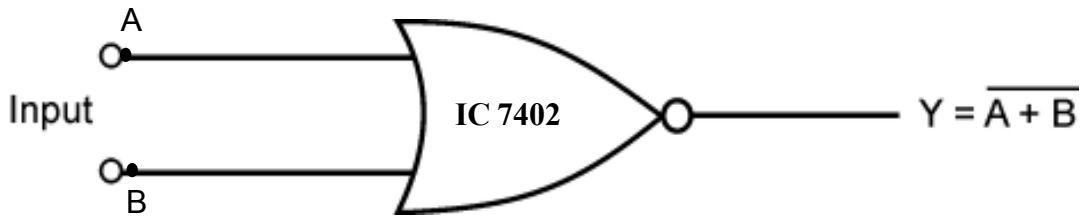

**Fig. 3(a)**

**NOR GATE CIRCUIT DIAGRAM**

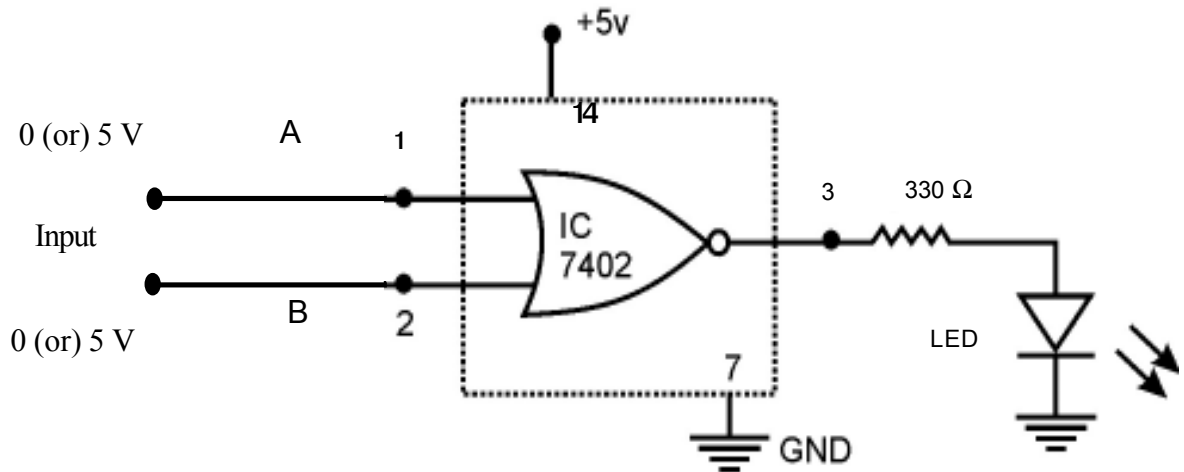

**Fig. 3(b)**

**NOR GATE PIN DIAGRAM OF IC - 7402**

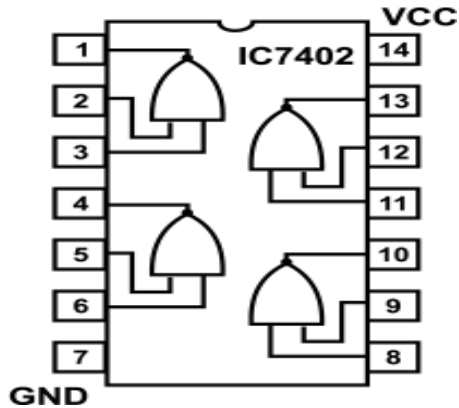

**Fig. 3(c)**

**TRUTH TABLE OF NOR GATE**

Logic inputs		Logic output
A	B	$Y = A+B$
0	0	1
0	1	0
1	0	0
1	1	0

**NAND GATE**

**LOGIC SYMBOL**

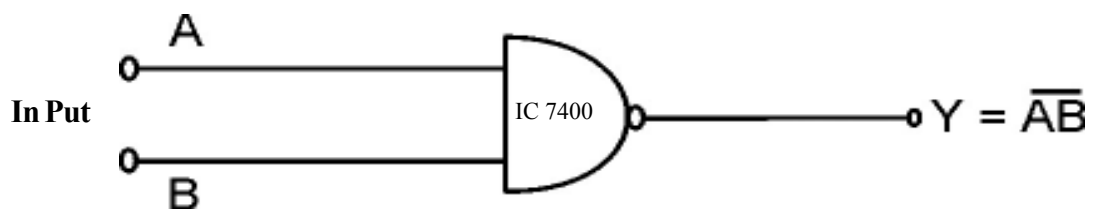

**Fig. 3(d)**

## NAND GATE CIRCUIT DIAGRAM

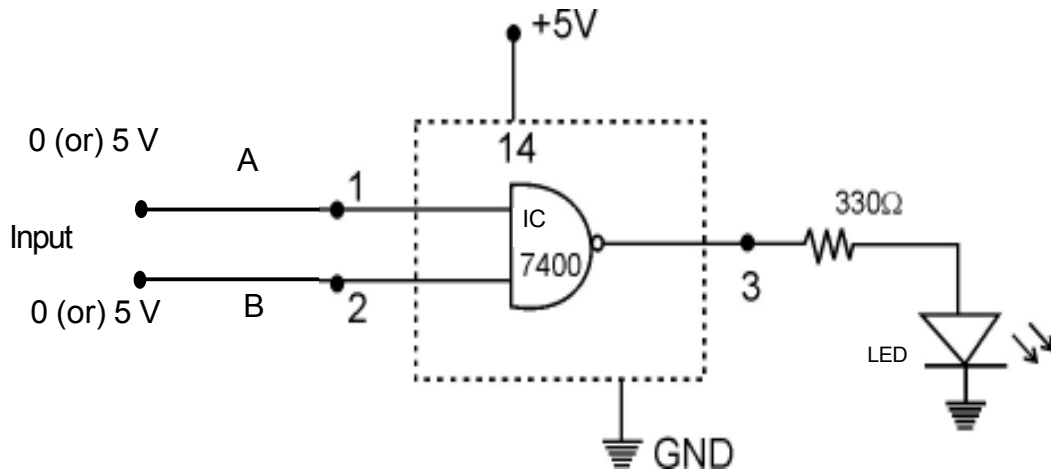

Fig. 3(e)

## IC 7400 PIN DIAGRAM: NAND GATE

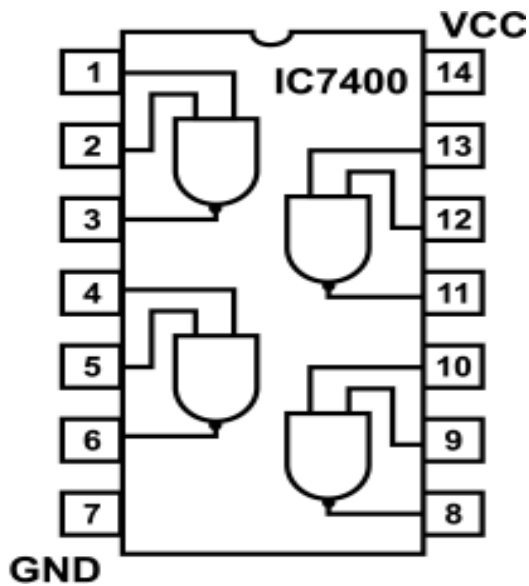

Fig. 3(f)

## TRUTH TABLE OF NAND GATE

Logic inputs		Logic output
A	B	$Y = AB$
0	0	1
0	1	1
1	0	1
1	1	0

## EX - OR GATE

## LOGIC SYMBOL

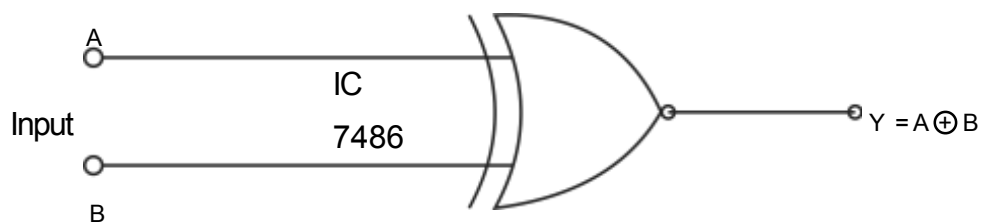

Fig. 3(g)

## CIRCUIT DIAGRAM EX - OR GATE

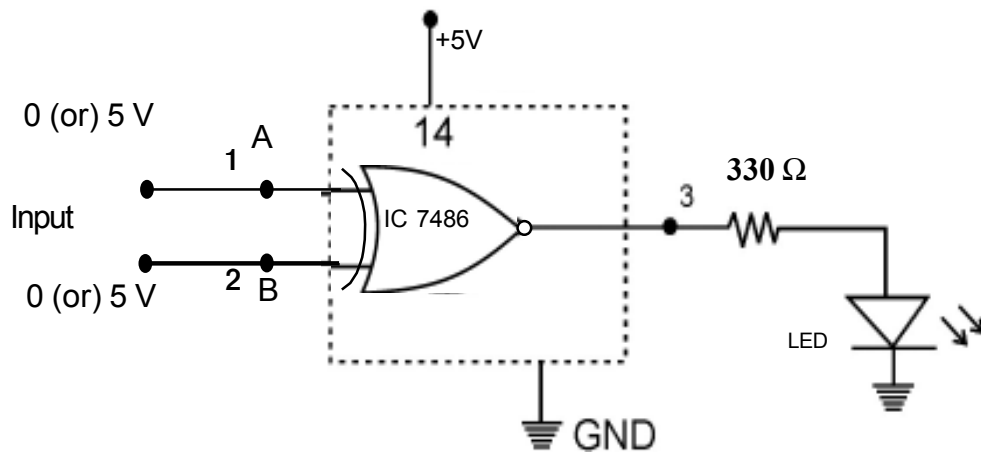

Fig. 3(h)

## IC 7486 PIN DIAGRAM OF EX - OR GATE

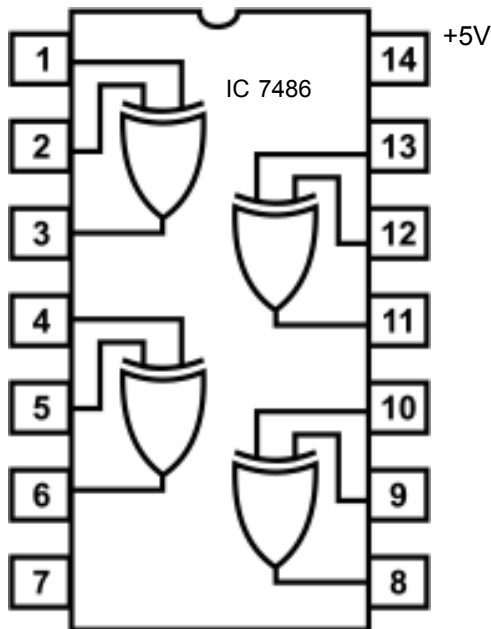

Fig. 3(g)

## TRUTH TABLE OF EX-OR GATE

Logic inputs		Logic output
A	B	$Y = A + B$
0	0	0
0	1	1
1	0	1
1	1	0

## NAND GATE

Combination of Nor and AND gate is called NAND gate. It is a Reverse operation of AND gate.

1. Boolean equation of NAND gate is  $Y = \overline{AB}$
2. Inputs of A, B is 0 (or) any one of the input is one and another is 0 means the o/p will be 1.
3. Operation of the NAND gate is verified from the truth table



## EX - OR GATE

- i) Diagram of Ex - OR gate shown using IC7486
- ii) Boolean equation for Ex- or gate  $Y = A + B = AB + AB$
- iii) Any one of the I/P is high mean o/p will be high.
- iv) It is verified from the truth table

## RESULT

Thus the study of logic gates NOR, NAND, EX-OR were done and the truth table is verified.

## EXPERIMENT NO - 4

### CONSTRUCTION AND TESTING OF HALF ADDER FULL ADDER AND FLIP - FLOPS

#### Aim

To study the two inputs of the arithmetic circuits of Half adder, Full adder and Flip flops using ICs.

#### Components Required

S.no	Name of Component/Apparatus	Quantity
1.	IC 7486	2
2.	IC 7408	2
3.	IC 7432	1

#### Half adder

1. A single logic circuit is used for adding two single bit binary numbers and the outputs are obtained as sum and carry.
2. Sum is got from the output of EX - OR gate and carry is obtained from the output of AND gate.
3. Here A and B are the inputs and sum (s) and carry (c) are the outputs.
4. Half adder can take only two inputs it doesn't take the third carry.

#### Full adder

1. A logic circuit that can be used for adding three single bit binary numbers and give the output of sum and carry
2. It takes three inputs including the output of EX-OR gate and carry is from the input of AND gate.
3. It is the form of two half adder with OR gate
4. It has three inputs A, B, and C and two outputs S and C.
5. The o/p sum is doing  $A+B+C$  and the other o/p carry is doing  $A.B + B.C + C.A$

## Flip Flop

Flip Flop is doing the action with the help of logic gates. It has one and more inputs and only two outputs. The inputs are 1 and 0 and it is stable while there is no change.

There many types of Flip -Flops, some are

1. SR Flip Flop
2. CSR Flip Flop
3. T - Type Flip Flop
4. D - Type Flip Flop
5. J.K Flip Flop

### 1. S-R Flip Flop (SET-RESET)

1. It is a basic circuit.
2. It has two inputs are set (s) and Reset (R) and has two outputs Q and Q
3. The diagram and the truth table shows the action.

### 2. CSR FLIP - FLOP : ( Clock Set Reset)

1. It is not possible for changing the input at once. So a clock pulse is used as clock SR Flip - Flop
2. It has three inputs S, R and C and outputs are obtained as Q and Q.
3. It is a combination of four NAND gates which is verified by using truth table.

### 3. T-TYPE FLIP FLOP :

It is used for calculation. So it is called Toggling flip-flop. By the input J and K are obtained the outputs as Q and Q which is verified by truth table.

### 4. D- TYPE FLIP FLOP :

It is the next stage of CSR Flip flop. It is used for memory the data's. so It is called Data flip flop we came to know the flip - flop by using the diagram and truth table.

### 5. J.K FLIP FLOP

1. CSR not allowed the input  $R = S = 1$  so we can do it through by J.K flip flop
2. It has four NAND gates.
3. Inputs are given and functional state diagrams are verified.

## 1. Half Adder

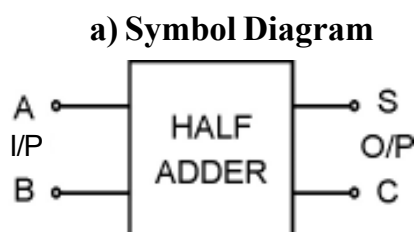

Fig. 4(a)

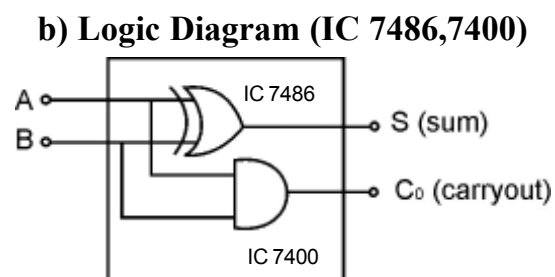

Fig.4(b)

## 2. Full Adder

### a) Symbol Diagram

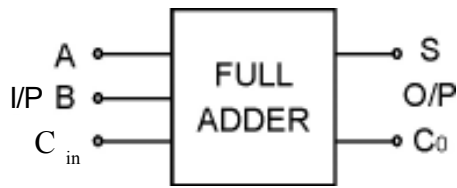

Fig :4(c)

### b) Logic Diagram (IC 7486,7400,7402)

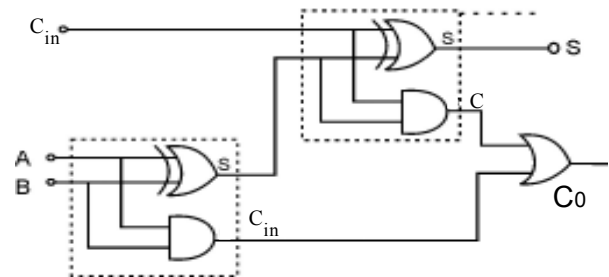

Fig :4 (d)

### Truth Table of HALF ADDER

LOGIC INPUTS		LOGIC OUTPUTS	
A	B	S	C <sub>0</sub>
0	0	0	0
0	1	1	0
1	0	1	0
1	1	0	1

$$S = A \oplus B$$

$$C_0 = A \cdot B$$

### Truth Table of FULL ADDER

LOGIC INPUTS			LOGIC OUTPUTS	
A	B	C <sub>in</sub>	S	C <sub>0</sub>
0	0	0	0	0
0	1	0	1	0
1	0	0	1	0
1	1	0	0	1
0	0	1	1	0
0	1	1	0	1
1	0	1	0	1
1	1	1	1	1

$$S = A + B + C$$

$$C_0 = A \cdot B + B \cdot C + C \cdot A$$

## FLIP-FLOP

### 1. SR Flip-Flop

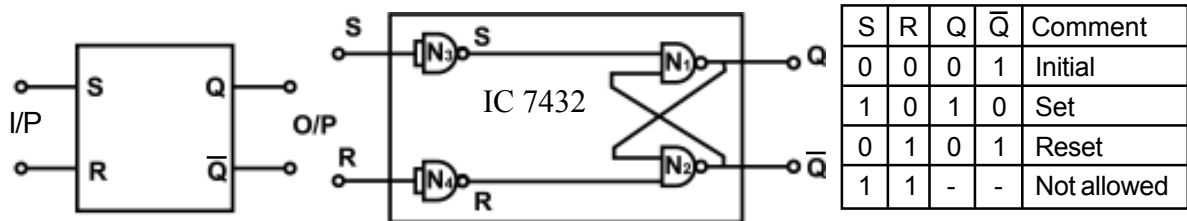

Fig. 4(e)

### 2. CSR Flip-Flop

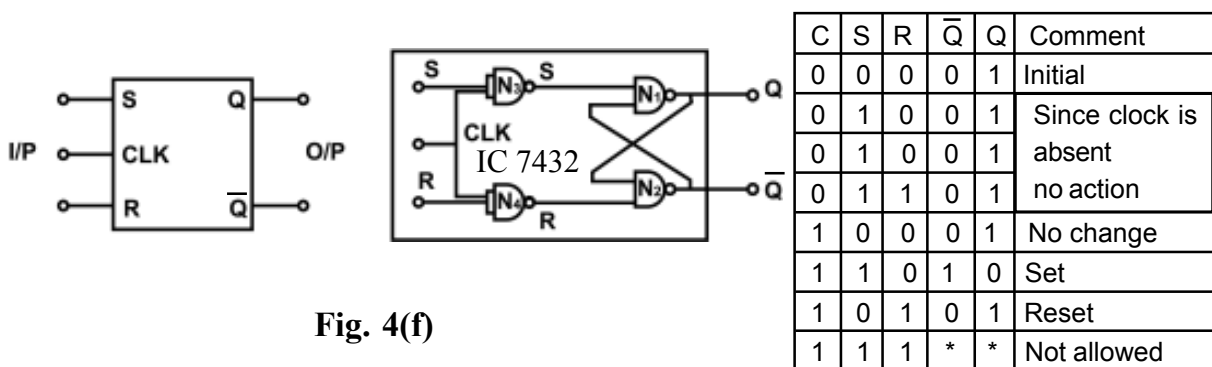
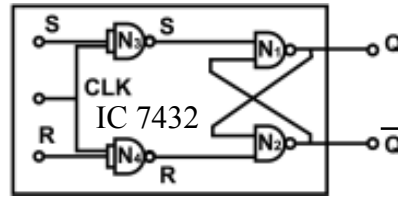
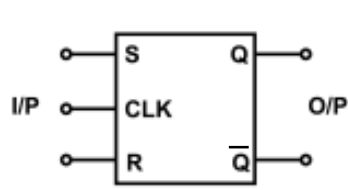

Fig. 4(f)

## 2. CSR Flip-Flop



### State diagram

C	S	R	$\bar{Q}$	Q	Comment
0	0	0	0	1	Initial
0	1	0	0	1	Since clock is absent no action
0	1	0	0	1	
0	1	1	0	1	
1	0	0	0	1	No change
1	1	0	1	0	Set
1	0	1	0	1	Reset
1	1	1	*	*	Not allowed

Fig. 4(f)

## 3. D-Type Flip-Flop

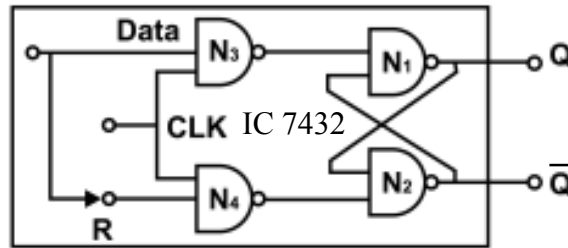
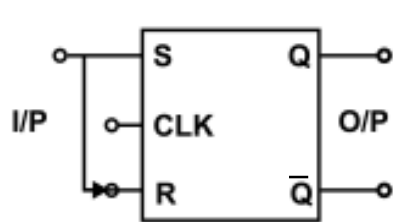

Logic Input	Logic Output	
D	Q	$\bar{Q}$
0	0	1
1	1	0

### State diagram

Fig. 4(g)

## 4. T-Type Flip-Flop

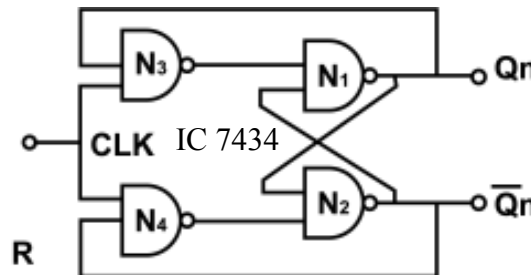
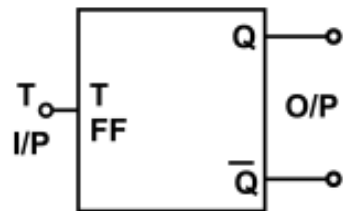

Logic Input	Logic Output
T	$Q_{n+1}$
1	$\bar{Q}_n$
1	$Q_n$

### State diagram

Fig. 4(h)

## JK - FLIP FLOP

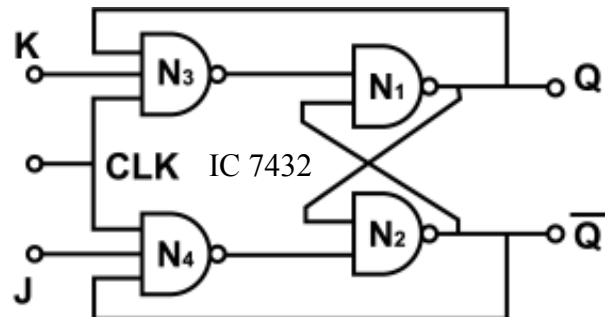
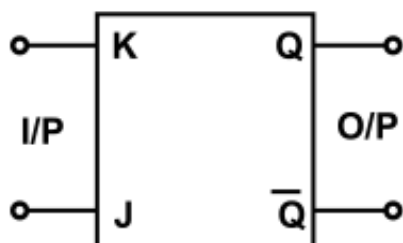

Fig. 4(i)

## State diagram

Logic input					Output
C	J	K	Q	$\bar{Q}$	Comment
0	0	0	0	1	Initial
0	1	0	0	1	Since clock is absent no action
0	0	1	0	1	
0	1	1	0	1	
1	0	0	0	1	No change
1	1	0	1	0	Set
1	0	1	0	1	Reset
1	1	1	1	0	Toggling
1	1	1	0	1	

## Result

Thus we study the circuits of half adder and full adder by using truth table. Flip-Flops are verified using the state diagrams.

## EXPERIMENT NO - 5

### ERECTION AND TESTING OF DISH ANTENNA

#### Aim

To study the installation and testing of dish antenna.

#### Components required

S.No.	Name of Components/Apparatus	Quantity
1.	DTH Antenna(Direct-To-Home)	1
2.	LNB(Low Noise Blockdown converter)	1
3.	Satellite receiver	1
4.	RG6 co-axial cable	25 metre
5.	TV	1 set

#### Dish Antenna

It is a receiver antenna which receives the signals propagated by the satellite and give to the T.V. Receiver.

#### Procedure for the Installation of Antenna

**I. Choosing the correct place :** First we should select the correct place for installation.

1. It must be an open place. Objects like trees, hills, buildings should be avoided because signals will be weak.
2. It should be visible and must be fixed in the direction of the satellite.
3. The place selected, must be 20 feet along the power line.
4. It can be installed on a terrace, upstairs, outwalls or pillar.

## II. Ground

A good grounded minimise the bad reactions.

1. The bad effects from, lightning and thunder affects the receiver. It may be shocked when operation, even death will also be happen. So it must be grounded properly.
2. We can make the ground with parallel to EB ground. Otherwise we can ground separately by using pipes.

## III. Assembling of Antenna

1. The antenna must be fixed very strong, even should not disturbed by any natural calamities such as strom, rain etc.
2. We can use the RG6 cable wires to connect the TV and the antenna.
3. The cable must be 25m length.
4. We can take the transmission line via walls or ground.

## IV. Fixing and testing of antenna

1. First choose the direction of the satellite and then fix the stand of dish antenna. After fixing, the antenna stability and strength must be checked.
2. Angle(AZ-EL) of the dish antenna must be checked and then it must be fixed with screws and bolts. [AZ side angle left to right, EL-up and down angle].
3. Then fix LNB with V shape bolt-nut at the opposite side of the dish.
4. Cable wire must be connected between T.V and antenna.

## Testing

1. Switch ON the T.V. and check the screen for clear vision and turn the antenna till clear vision is obtained.
2. Even if the picture is not clear, adjust the dish AZ(Azimuth) and EL (Elevation) correct position to get clear image.
3. If all channels are screened clear, stop the adjustment, Note the noise level in LNB which must be in high level.
4. If all the adjustments are done correctly, note the angle of the dish (EL and AZ) at the back side which is used in future purpose.
5. It is an important point, there is no iron objects while adjusting the angle. Because it make wrong deflection in the meter.
6. If all are correct again check the strength of dish.

## Some standard angles given

Place	Latitude	Longitude	AZ	EL
Mumbai	18.93N	72.85E	128.56	56.37
Delhi	28.67N	77.23E	146.26	51.24
Chennai	13.08N	80.30E	130.79	67.03
Salem	11.63N	78.13E	123.63	66.09

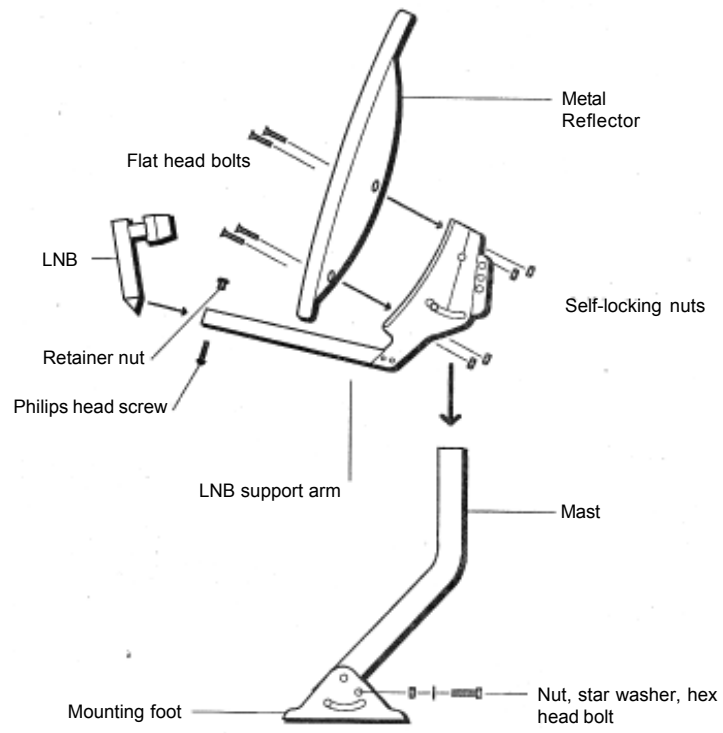

**Fig. 5(a) : Separate parts of Dish antenna**

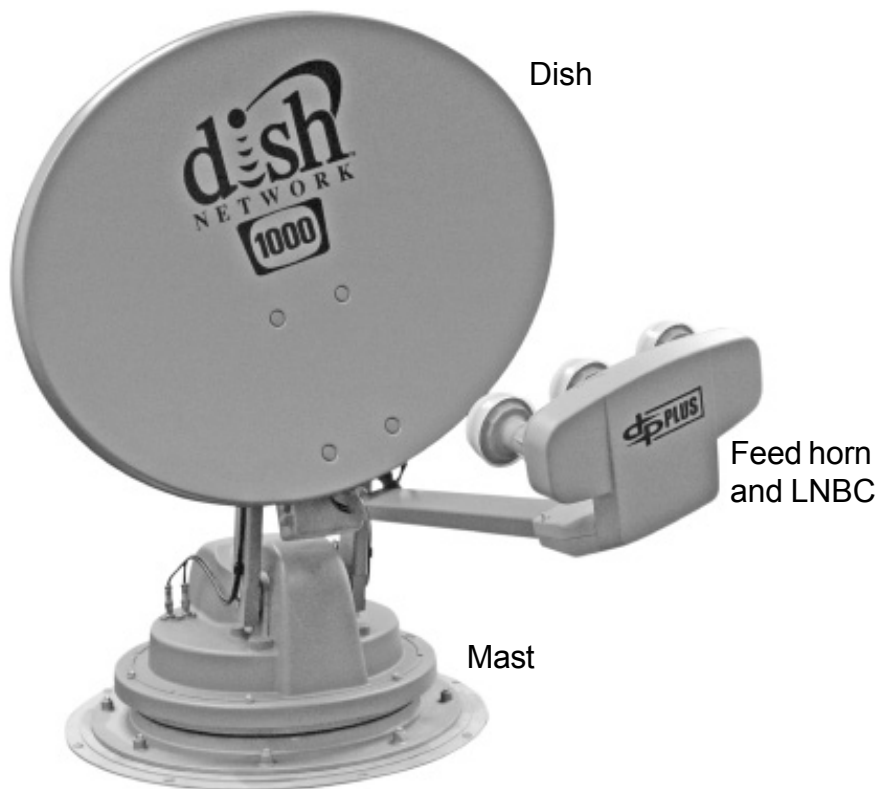

**Fig. 5(b) : Dish antenna**

### ROUTING CABLE THROUGH THE MAST

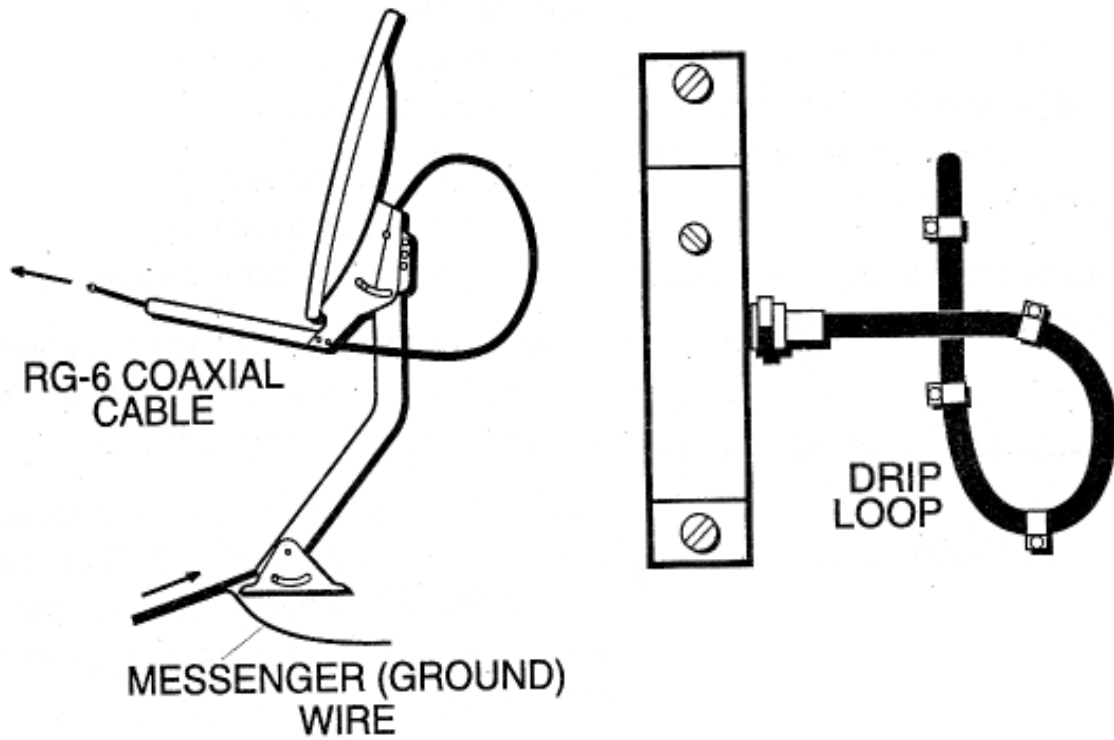

Fig. 5(c)

### Result

Thus, a dish antenna is installed and tuned the picture obtained clearly in the screen.



## EXPERIMENT NO - 6

### CONSTRUCTION OF AUDIO AMPLIFIER USING TBA 810 IC.

#### Aim

To construct an audio amplifier using TBA 810 IC.

#### Components required

S.No.	Name of Components/ Apparatus	Range	Quantity
1.	IC	TBA 810	1
2.	Speaker	4"8W	1
3.	Volume control	10k $\Omega$	1
4.	Resistor	100k $\Omega$	1
		150 $\Omega$	1
		56 $\Omega$	1
		1 $\Omega$	1
5.	Capacitor	0.1 $\mu$ f	1
		0.01 $\mu$ f	1
		0.0047 $\mu$ f	1
		330pf	1
		220 $\mu$ fd/12V	3
		100 $\mu$ fd /12V	2
6.	DC Power supply	6V	1
7.	Multimeter		1

#### Procedure

1. Assemble the circuit with the given components.
2. 0.1mf capacitor is conned to pin 8 and volume control centre point are connected.
3. Pin 9 and 10 are grounded.
4. Connect the speaker between pin 12 and ground.

After completing the arrangements, +6v power supply line is given to pin 1 as in the circuit. Then operate the amplifier and note down the voltage in every pins of the IC.

#### Results

Thus the audio amplifier is assembled using TBA 810 IC and voltages are noted down.

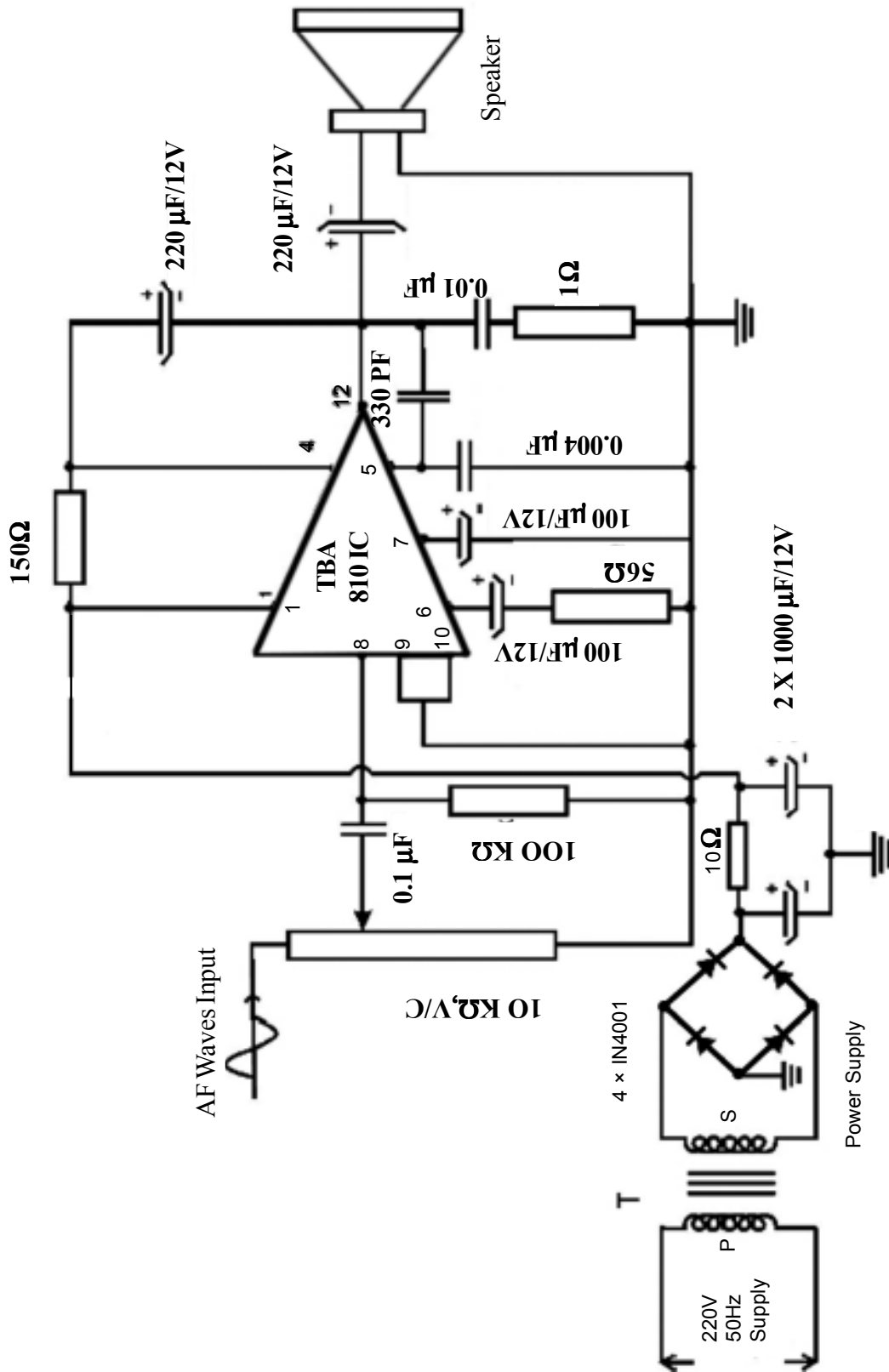

Fig. 6 : Audio amplifier and Output stage using TBA 810 IC

## EXPERIMENT NO - 7

# CONSTRUCTION AND TESTING OF ENCODERS AND DECODERS

### Aim

To study the function of Encoder and Decoder.

### Components Required

S.no	Name of Component/Apparatus	Quantity
1.	IC 74147	1
2.	IC 74148	1
3.	IC 7442 or 7447	1
4.	7 segment display	1
5.	Resistor 330W	4
6.	LED	10

### 1. Encoder

Encoder is a circuit, which connect the human codes into machine code. It is used for switching purposes in numerical code devices.

#### Decimal - BCD Encoder

When we press the (0-9) switches. It is converted as corresponding BCD code. (i.e Decimal to Binary) for that NAND gates is used with IC 74147. Table shows the decimal to four digital binary.

<b>0</b>	<b>0000</b>
<b>1</b>	<b>0001</b>
—	----
—	----
<b>9</b>	<b>1001</b>

**Example :** While pressing switch 3, the o/p is shown as 0011.

#### Octal to Binary Encoder

1. It uses IC 7448 and NAND gate.
2. It is used to convert octal number into binary number. Example, the number 537 is convert to binary code as 1101101011.
3. This circuit is used to save and give the binary numbers.
4. In this we can also get output for least value of the input.

### 2. Decoder

Decoder is a digital mixer type circuit. It converts the given digital code into necessary corresponding number.

#### BCD to 7 segment Decoder

Seven segment display is most popular one. It converts BCD into numerical form. Using Ic 744 the inputs and outputs are shown in figure.

## 1. Encoder - IC - 74147 with LED-2

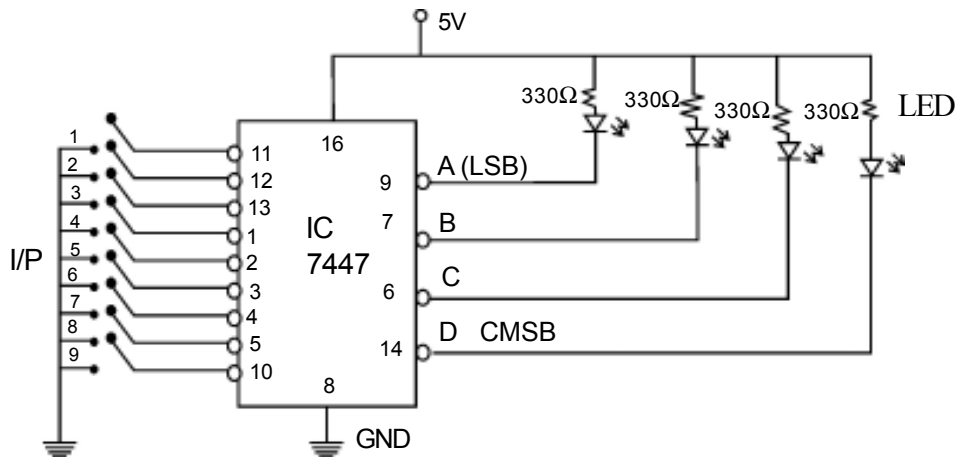

Fig. 7(a) BCD - to 7 Segment D-Coder (2 digits - 7 pieces)

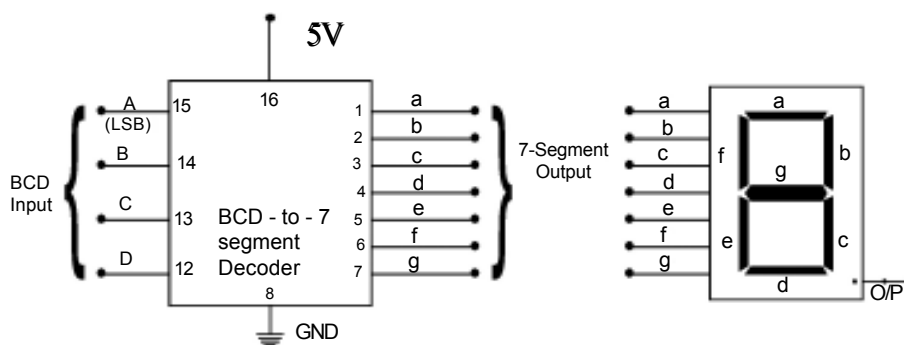

Fig. 7(b) Decimal - BCD - Encoder (Decimals - Digits)

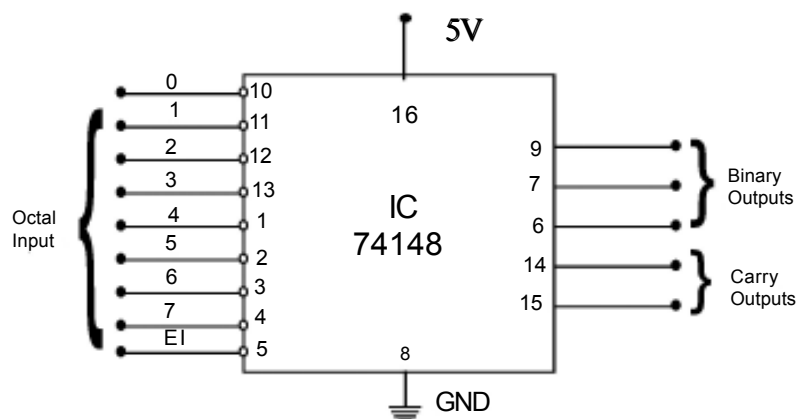

Fig. 7 (c) Octal - BCD - Encoder(Eight digits - Digits)

1. There are four inputs A,B, C, D and a to g seven outputs.
2. a to g outputs are connected to 7 segment LED.
3. 7 segment LED anodes are considered same cathodes.

### Result

Thus the functions of the Encoder and Decoder using IC were understood.

## EXPERIMENT NO - 8

### CONNECT AND MEASURE THE VOLTAGES OF VARIOUS STAGES IN AM RADIO RECEIVER

#### Aim

To construct an A.M radio receiver and measure the voltages at various stages.

#### Components required

S.No	Name of Component/Apparatus	Quantity
1.	AM radio receiver	1
2.	6V DC power supply	1
3.	AVO meter or multimeter	1

#### Procedure

- 1) Connections are given as per the block diagram.
- 2) A power supply (6V DC) is given to the radio receiver.
- 3) Using multimeter (or) AVO meter. Measure the potentials of transistor at various stages as follows
  - a) Converter stage
  - b) IF amplifier stage
  - c) Audio amplifier and
  - d) Audio output stage

#### Tabulation

S.No	Name of the Transistor	Section	Voltage(in v)		
			B	E	C
1.	BF 194 B	Convertor	0.5	0	5.8
2.	BF 195 C	IF Amplifier	0.8	0	5.7
3.	BF 195 D	IF Amplifier	0.8	0	5.8
4.	BC 548 B	Audio Amplifier	0.5	0	5.5
5.	BELL 188 I	Audio output	3.8	6	3
6.	BELL 188 II	Audio output	1.2	3	0

#### Result

Thus, the voltages at various stages in a A.M radio receiver is checked for its normal operation.



## EXPERIMENT NO -9

### ASSEMBLE A F.M RADIO RECEIVER AND DETERMINE ITS POTENTIAL AT VARIOUS STAGES

#### Aim

To study the functional block diagram of F.M radio receiver and measure its potential at various stages.

#### Components required

S.No	Name of Components/Apparatus	Quantity
1.	FM radio receiver	1
2.	6V DC power supply	1
3.	AVO meter or multimeter	1

#### Procedure

1. Connections are given as per the block diagram.
2. 6v DC power Supply is given to FM receiver.
3. Multimeter (or) AVO meter is used to measure the potential of transistor at various stages as follows
  1. Converter stage
  2. IF amplifier stage
  3. Audio amplifier and
  4. Audio output stage

S.no	Stages	Voltage	
1.	CAX1619 IC I/P Voltage	6Vdc	
2.	Audio amplifier and O/P IC TBA810	Pin no	Voltage (in v)
		1	+ 6 VDC
		2	0
		3	0
		4	+ 5.9
		5	+ 1
		6	+ 1.2
		7	+ 3.8
		8	0
		9	0
		10	0
		11	0
		12	+ 3.2

#### Result

Thus the potentials at various stages of an F.M. Radio receiver is measured and verified with the table for its normal operation.

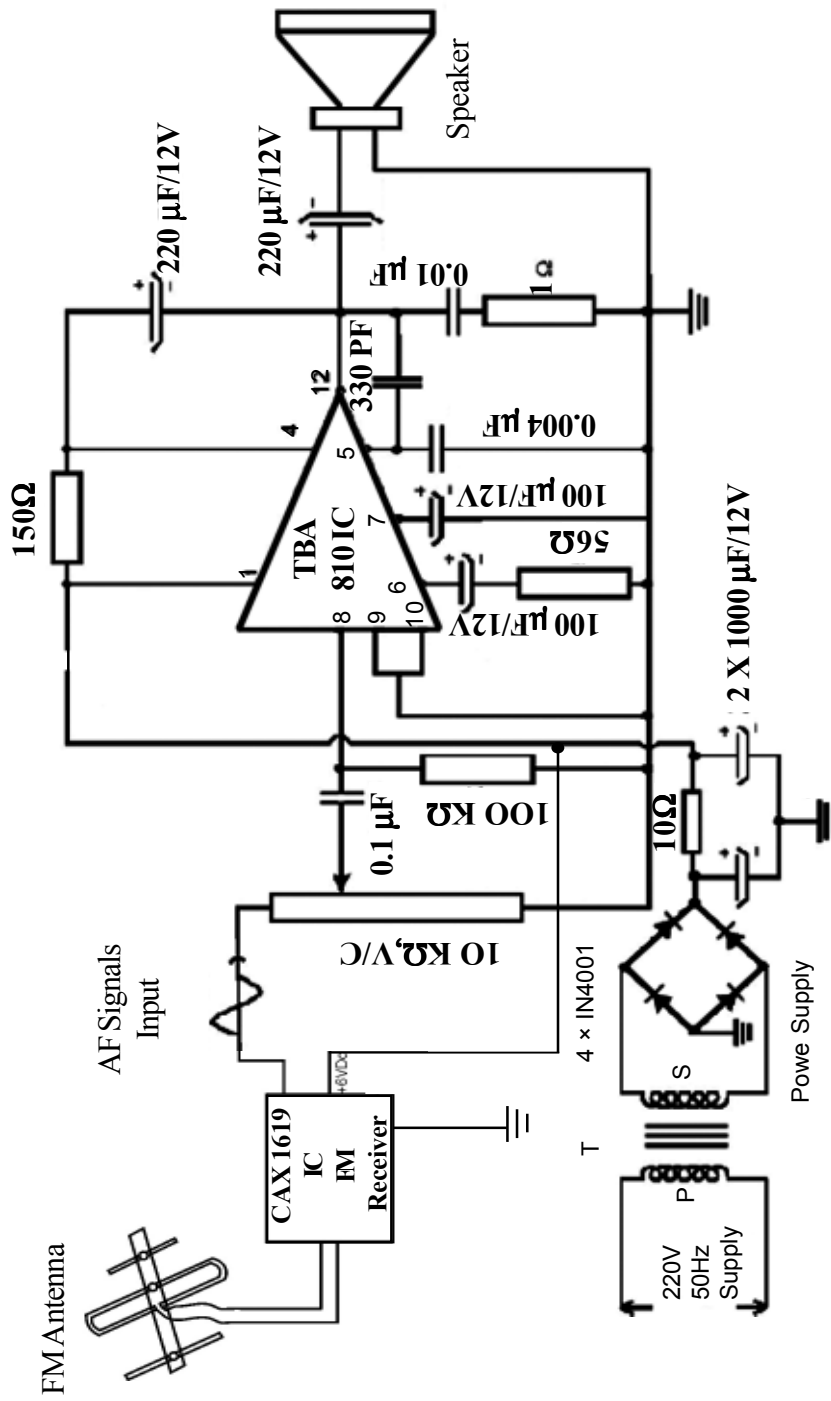

FIG. 9 : FM RADIO RECEIVER



## EXPERIMENT NO - 10

### TROUBLE SHOOTING AND RECTIFICATION OF THE FAULT IN A AM RECEIVER

#### Aim

To identify and rectify the faults in a AM receiver.

#### Components Required

S.No	Name of Components/Apparatus	Quantity
1.	AM receiver under fault condition	1
2.	Multi meter	1
3.	RF/AF Singal Generator	1

#### Fault Detection

Generally two types of faults are occurred in radio receiver. They are

1. Live fault
2. Dead fault

First we have to find that, which type of fault is present in the receiver.

#### 1. Live fault

Switch on the receiver, and tune the receiver to a particular channel programme. The fault when there is no programme and on hearing only distortion sound is live fault.

#### Type of Live faults

1. Low volume, 2. Hum sound or noisy sound, 3. Motor boating sound,
4. Whistling sound , 5. Intermittent fault

#### 2. Dead fault

On switching the power supply of receiver ,if there is no sound in the speaker of radio receiver;the fault is known as dead fault.

#### Procedure

1. When there is no sound in the speaker, while switching on the power supply,the fault is confirmed as dead fault.
2. Set the input voltage as 6v
3. And measure the voltage at audio amplifier and output of the receiver check for the correct refernce voltages.
4. Check the speaker, there is a open fault made at voice coil of the speaker, it is conformed.
5. So, faulty speaker is removed,and new speaker is connected by soldering process.
6. Now switch on the receiver, It is working correctly.

#### Result

Thus the fault of AM radio receiver is detected and approximately is rectified successfully.

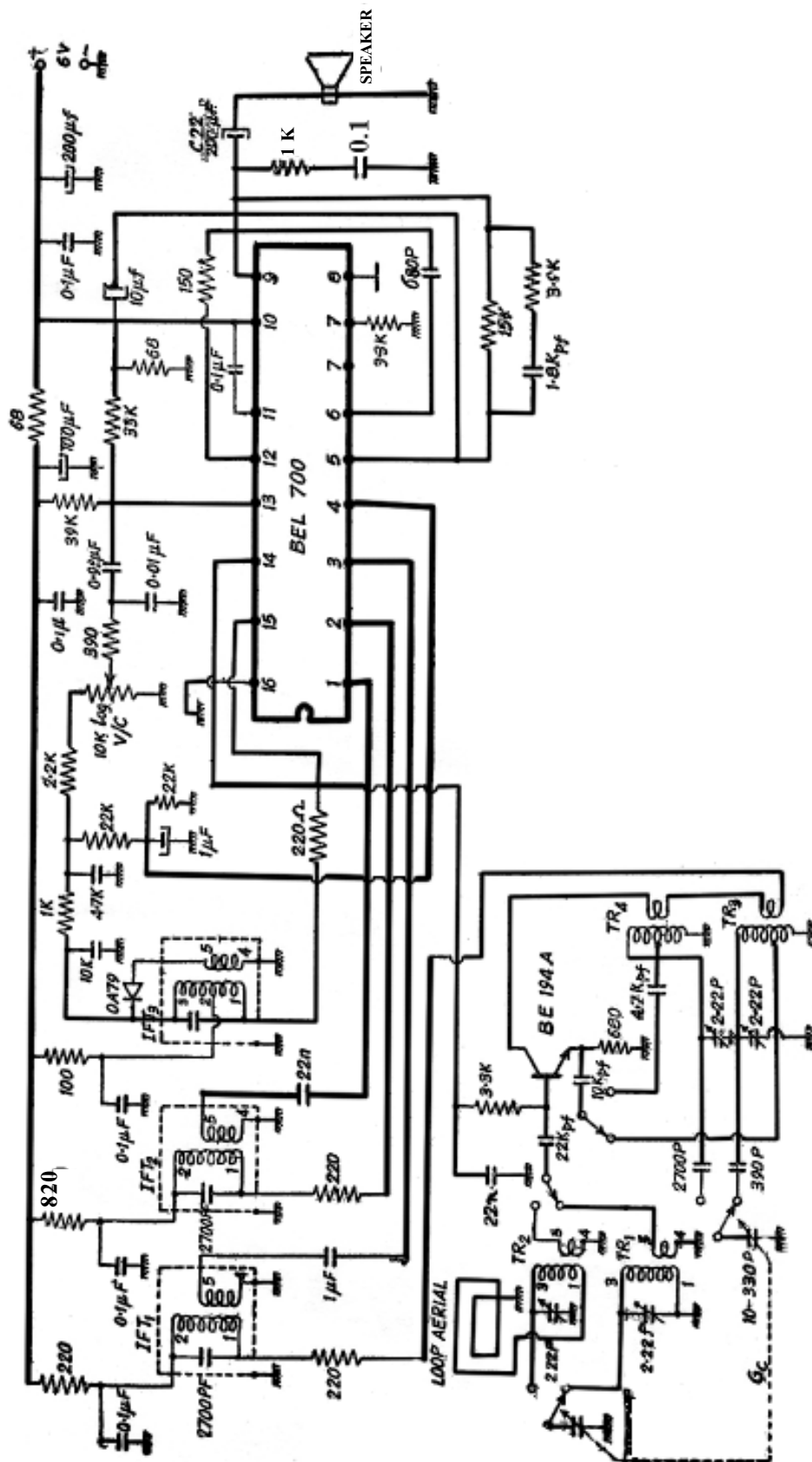

FIG. 10 : AM RADIO RECEIVER USING BEL 700IC

## EXPERIMENT NO - 11

### FIND THE FAULT IN FM RADIO RECEIVER AND REPAIR IT

#### Aim

To find the fault in FM radio receiver and rectify it.

#### Components Required

S.No	Name of Components/ Apparatus	Quantity
1.	Faulted FM radio receiver	1
2.	Multimeter	1
3.	RF/AF signal generator	1

#### To find the fault which occurred in Radio receiver

There are two type of fault in radio receiver.

1. Live fault
2. Dead fault

We have to find which one of the above fault occurred in radio receiver.

#### Live fault

We have to switch on the radio and to select a program channel. In this, there is only noisy sound in the speaker without any programme, this fault in radio receiver is called live fault.

#### Types of live fault in FM receiver

1. Low volume
2. Hum sound noisy sound
3. Intermittent fault
4. Whistling sound
5. Motor boating sound

#### Dead fault

If there is no sound when we switch on the radio receiver, then the fault is called dead fault.

#### Test

1. Switch on the radio receiver and select the programme, while hearing the programme, the volume is low from the speaker.
2. The volume is low, even we raise the volume control. So there is low volume fault.
3. Then measure the voltage of the power supply, but it is showing correct value.
4. Then measure the voltage in TBA810 IC while seeing the voltage is being low.
5. Then decided that the fault is in TBA810IC, so replace the IC with new one.
6. Then switch on the receiver, it functions normally.

#### Result

Thus the fault in the radio receiver is found out and it has been rectified successfully.

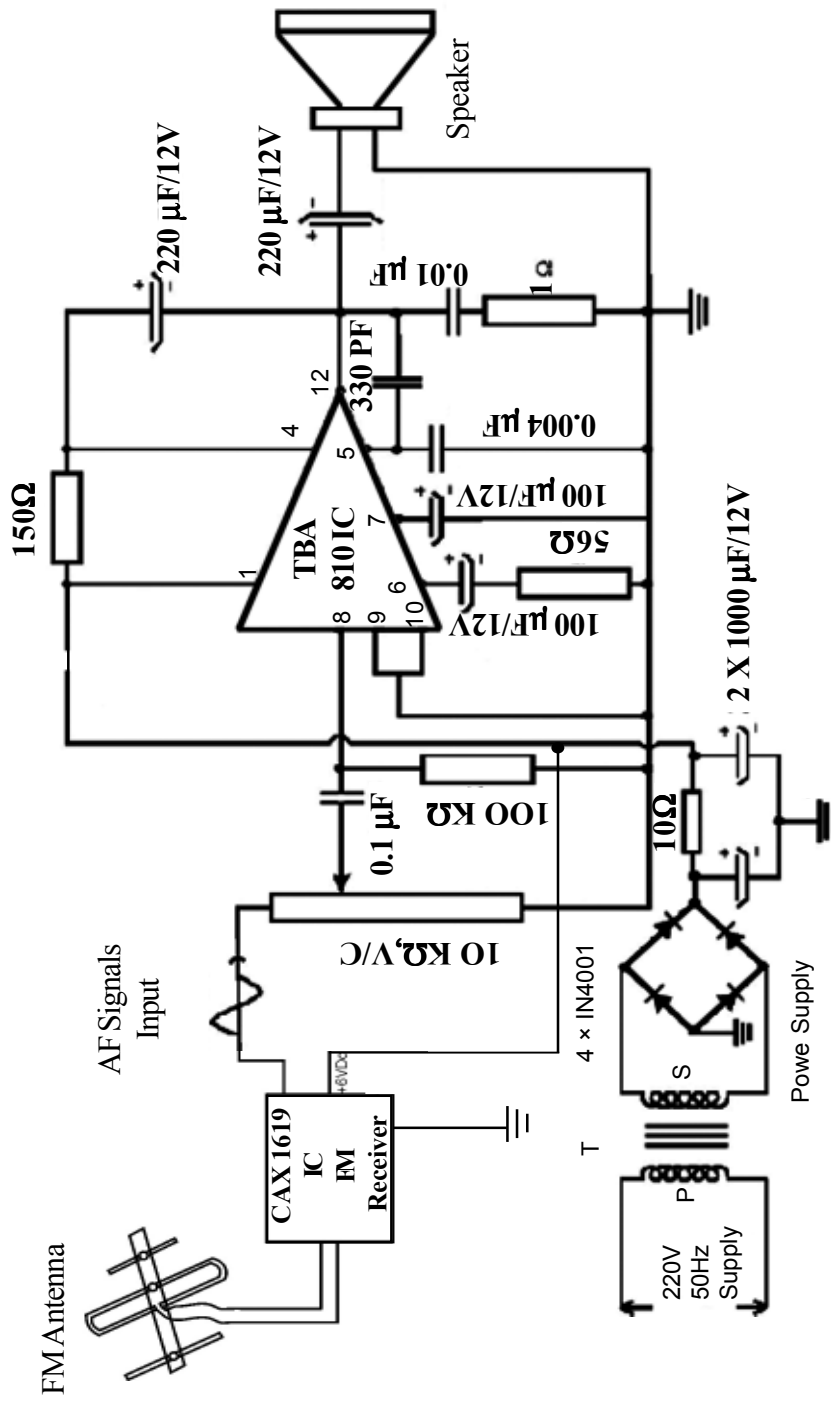

FIG. 11 : FM RADIO RECEIVER

## EXPERIMENT NO - 12

### CONSTRUCTION OF FM RADIO USING CAX 1619 AND TBA 810 IC AND OPERATE IT

#### Aim

To construct the circuit of FM radio receiver using CAX 1619 and TBA 810 IC and operate it.

#### Components Required

S.No	Name of Components/Apparatus	Quantity
1.	FM circuit board CAX-1619 IC	1
2.	Audio circuit board TBA 810 IC	1
3.	FM Antenna	1
4.	Speaker 8W/5W	1
5.	6V DC power supply	1
6.	Multi meter	1

#### Experiment

1. Connect all the electronic components by using soldering Iron, as per the circuit diagram.
2. FM Antenna is connected with corresponding to CAX 1619 IC.
3. IN CAX 1619 circuit board, upper end of the volume control is connected to output and Hot end is connected to input of TBA 810 IC.
4. Earth end of volume control is connected to ground.
5. Speaker is connected to the audio circuit boards and connected it to the power supply.
6. Switch on the power supply, and adjust the gang condenser, select FM station programme.

#### Result

Thus the FM radio receiver has been checked and operated successfully.

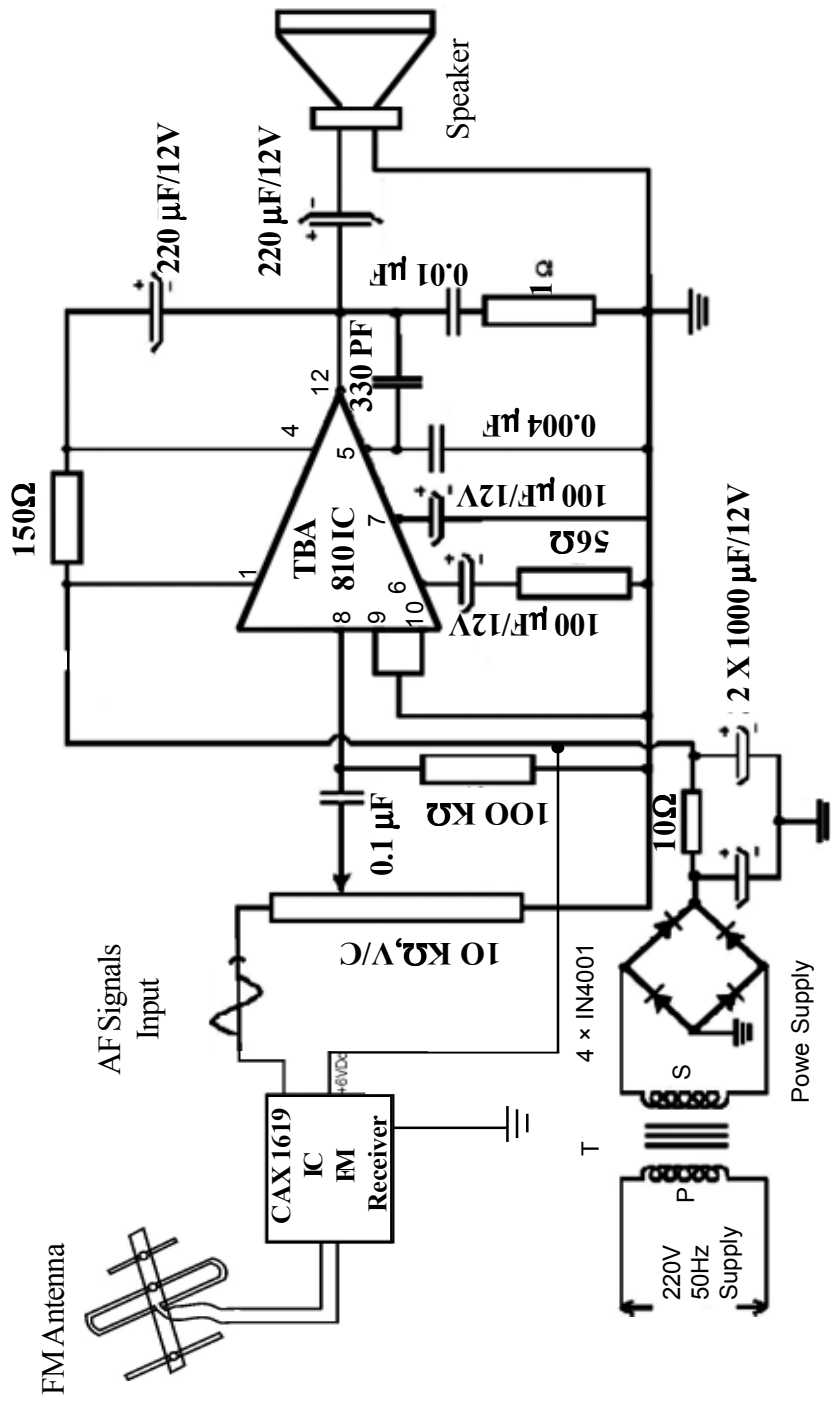

FIG. 12 : FM RADIO RECEIVER USING CAX 1619 IC & TBA 810 IC

## EXPERIMENT NO - 13

### RECTIFY THE WEAK SOUND (LOW VOLUME) IN AM RADIO RECEIVER.

#### Aim

To find the fault occurred (low sound) in a AM radio receiver and rectify.

#### Components Required

S.No	Name of Component/Apparatus	Quantity
1.	AM radio receiver under fault condition	1
2.	AVO meter or Multimeter	1
3.	RF / AF signal generator	1

#### Procedure

1. Switch ON the receiver.
2. There is low volume in the speaker.
3. Even on raising the position of the volume control knob, the volume will not increase.
4. So it is confirmed, that the fault is low volume which is the live fault.

#### Possible Stages

1. Power supply.
2. Audio amplifier and output.
3. IF amplifier and detector.

#### Testing

1. To measure the voltage of the power supply.
2. The voltage is below 6V DC. So disconnect the power supply separately and then measure the voltage again. Now it shows the correct voltage.
3. It is confirmed that the fault is occurred in audio amplifier and output stage.
4. To check the coupling condenser, it is in leakage condition. So disconnect the condenser and connect a new one with same value.
5. Now check the radio receiver, it will function with the high volume.

#### Result

Thus the fault is rectified and bringing to the normal operation of the receiver successfully.





## **EXPERIMENT NO - 14**

### **IDENTIFY THE FAULT OCCURED IN AM RADIO RECEIVER ( 50 Hz HUM SOUND) AND RECTIFIED IT**

#### **Aim**

To identify and repair the fault (50 Hz Hum sound) occurred in AM radio receiver.

#### **Components Required**

<b>S.No</b>	<b>Name of Component / Apparatus</b>	<b>Quantity</b>
1.	AM radio receiver	1
2.	AVO or Multi meter	1

#### **Test the receiver**

1. Switch on the receiver.
2. Hear the programmes with 50 Hz hum sound.
3. So conform the fault must be 50 Hz hum sound.

#### **Stages where the fault occur**

1. Power supply
2. Audio amplifier and output
3. IF Amplifier

#### **Test**

1. Switch ON the receiver and hearing the hum sound.
2. First testing the power supply part, the transformer gets heated.
3. Then switch OFF the receiver and test the Transformer.
4. On seeing the core of the transformer coiled loosely.
5. Decided the fault is present in the transformer.
6. Then changed the new transformer instead of faulted one.
7. Then switch ON the receiver and hear the programme without hum sound.

#### **Result**

Thus identify the fault (50 Hz Hum sound) occurred in AM radio receiver and rectified successfully.

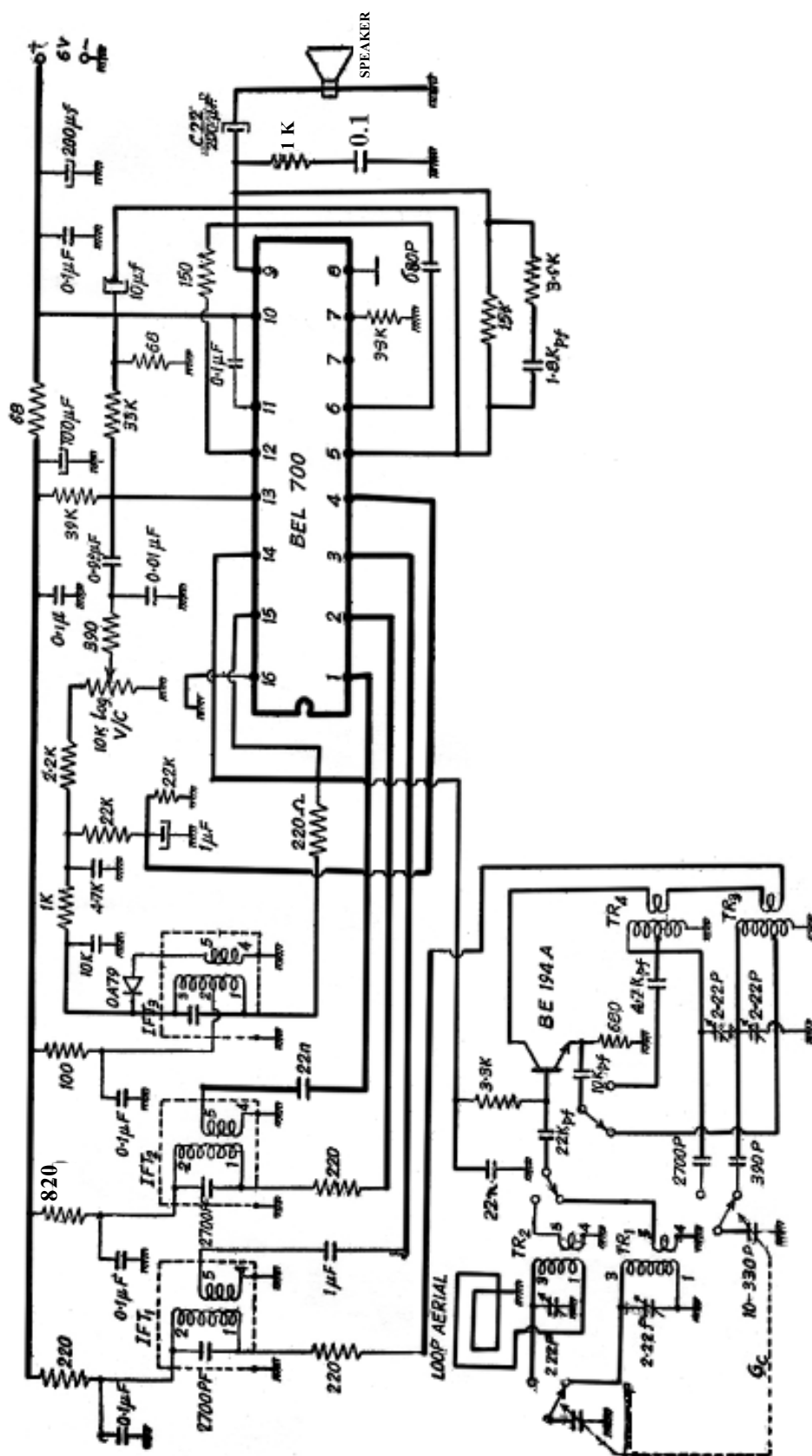

FIG. 14: AM RADIO RECEIVER USING BEL 700IC

## EXPERIMENT NO - 15

### RECTIFY THE FAULT IN FM RECEIVER - NOISY RECEPTION

#### Aim

To find the fault occur in a FM radio receiver (Noisy reception).

#### Components Required

S.No	Name of Component / Apparatus	Quantity
1.	FM receiver under fault condition	1
2.	AVO meter or Multi meter	1

#### Procedure

1. First switch ON the receiver, hearing the programme with noisy sound.
2. So it is conform, the fault is noisy reception.

#### Fault occur in possible stages

1. Antenna and Tunner stage
2. Oscillator
3. Detector and filter
4. Audio Amplifier and output.

#### Testing

1. When switch ON the receiver, there a noisy reception is heard.
2. While tuning the gang capacitors the noisy reception did not change.
3. Even aligning the trimmers the noise is not decrease.
4. Now adjust the core of oscillator coils, the noise is decrease. Then sealed the oscillator coils with wax.

#### Result

Thus the fault of noisy reception in a FM radio receiver is rectified.



## PRACTICAL - II

### EXPERIMENT NO - 1

## STUDY OF PATTERN GENERATOR AND FUNCTION GENERATOR (WITH COUNTS)

### Aim

To study the basic working of pattern generator and function generator (with counts).

### Components Required

S.No.	Name of Components / Apparatus	Quantity
1.	Pattern generator	1
2.	Function generator	1

### Pattern Generator

It is an electronic equipment used for tuning and aligning the Television receivers. So it produce various kinds of bars, lines and sounds.

### Procedure of using a Pattern generator front Panel Controls

1. Using co-axial cables connect R.F out and television receiver. Then adjust the R.F attenuator simultaneously.

#### 2. Horizontal Bar Pattern

Using this control, we can adjust the vertical size, linearity of the picture.

#### 3. Vertical Bar Pattern

Using this control, we can adjust horizontal, size, linearity of the picture.

#### 4. Cross Hatch Pattern

Using this control, we can adjust the align, the horizontal and vertical stages. Also we can adjust focusing.

#### 5. Dot Pattern

In colour television we can do convergence using this control.

#### 6. Pure white Pattern

Using this control, we can adjust the black level and white level in colour television.

7. We can align or sync the sound section also.

### Application of Pattern Generator

1. Vertical and horizontal linearity and height of the picture can be adjusted.
2. Aspect ratio, Pincushion adjustment and centering of the picture can be done, using pattern generator.
3. Contrast, brightness, and focusing can also be adjust correctly.

## PATTERN GENERATOR

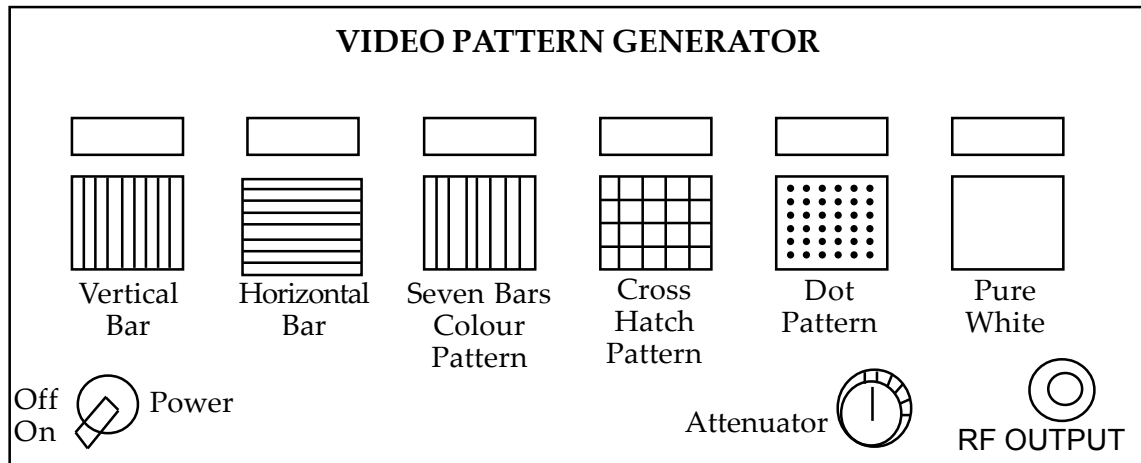

**Fig.1 (a) Front view of Pattern Generator**

4. R.F. stage and I.F stage in sound section can be aligned using this generator.
5. In colour TV, Tuning the colour perfectly, convergence and purity can be done using this generator.
6. When there is no programme, we can service the TV receiver using pattern generator.

### Function Generator

The function generator is an instrument which generates different type of the wave forms which are sine, square and triangular.



**Fig. 1 (b) FUNCTION GENERATOR**

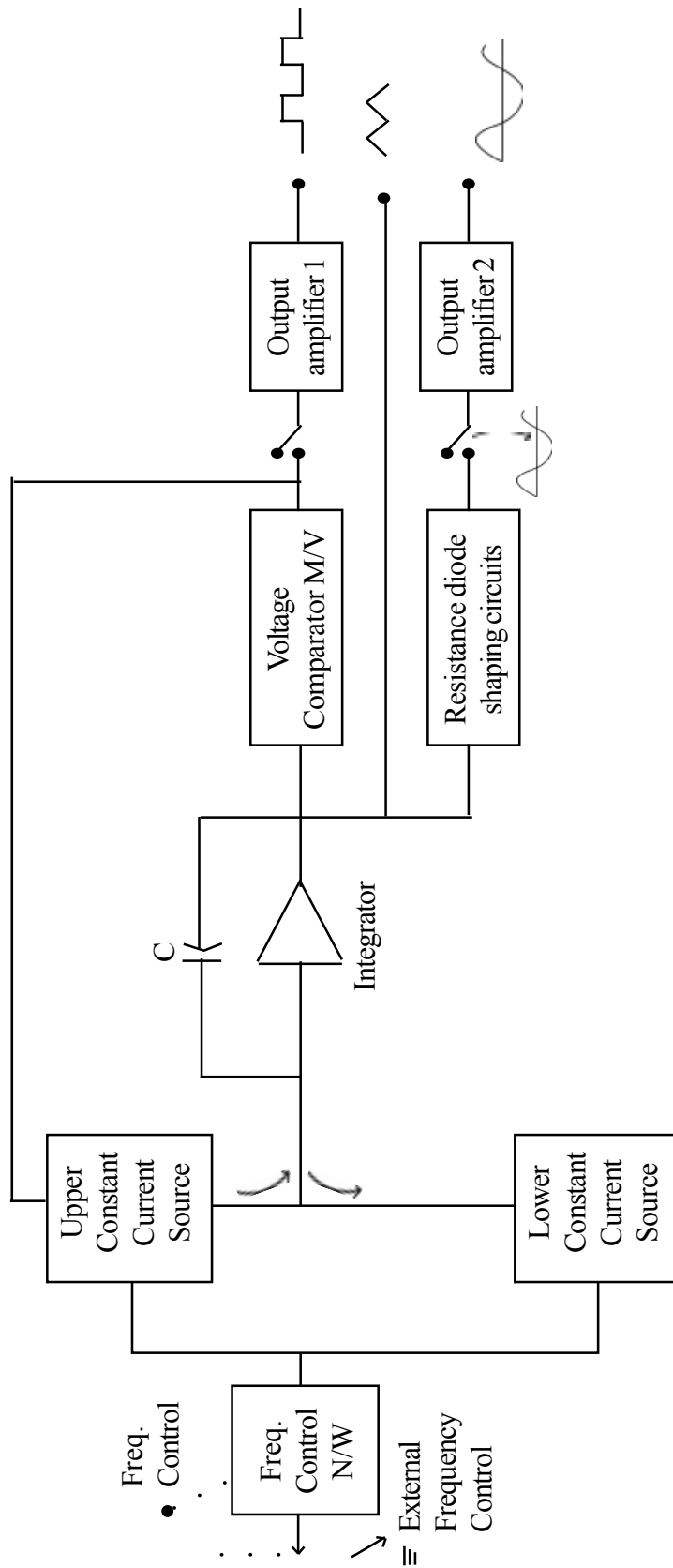

**Fig. 1 (c) : BLOCK DIAGRAM OF FUNCTION GENERATOR**

## **Front panel controls and its operation**

1. The frequency control is used to regulate two current sources namely,
  1. Upper current source
  2. Lower current source
2. The upper current source supplies current to an Integrator. The output voltage of integrator then increases changing the linearity with time. If the current, changing the capacity increases or decreases the slope of the output voltage increases or decreases respectively.
3. The voltage comparator multivibrator circuits changes the state of the network. This change in state, the upper is removed and the lower is 'ON'. The voltage comparator multivibrator stage is changing the condition of the network by switching 'OFF' the lower current and switch 'ON' the upper current source.

## **4. Different types of waveforms**

1. The output voltage of integrator has a triangular waveform which supplies by upper and lower current source.
2. To get square wave the output of the integrator is passed through comparator.
3. The sine wave is derived from triangular wave. The triangular wave is synchronized into sine wave using diode resistance network.

## **5. Amplifiers**

The two output amplifiers provide two simultaneous individually selected outputs of any of the wave form functions.

## **6. Features of function generator**

1. The frequency range is about 0.01 HZ to 100 KHZ.
2. It can provide various wave forms such as sine wave, saw tooth wave, triangular wave and square wave.
3. The accuracy is with in  $\pm 1\%$  in low frequency range.

## **Result**

Thus the various functions of pattern generator and function generator, were studied.



## EXPERIMENT NO - 2

### RECTIFICATION OF THE FAULT AND OPERATION OF A TV RECEIVER

#### Aim

To rectify the fault and operate the given TV Receiver (Dead Fault)

#### Components required

S.No.	Name of Component/Apparatus	Quantity
1.	TV Receiver	1
2.	Multimeter	1

#### Identify the Fault given on TV Receiver

1. Switch ON the TV Receiver
2. There is no picture, raster and sound effects in it.
3. So it confirms the receiver is under dead fault condition.
4. Switch OFF the TV Receiver immediately.

#### Test the stages of the TV Receiver (referring to block diagram fig. 2)

1. First switch ON the TV receiver and measure the AC input 220V/50HZ supply if it is Correct.
2. Check the ON-OFF switch if it is correct.
3. Then Check AC Fuse, Bridge rectifier diodes section, DC filter condenser and resistors related to power supply stage, If the voltage at the power supply is correct, proceed to next step.
4. Then measure voltage at horizontal output transistor if it is low switch OFF the receiver immediately and check the horizontal output transistor if it is correct go to next step.
5. To Confirm the LOT ( Line Output Transformer) is under fault condition. Remove the Fault LOT and Solder New one.
6. Then Switch ON the TV receiver, TV operates as dead fault is rectified.

#### Result

Thus the dead fault was rectified in a TV and normal operation was ensured.

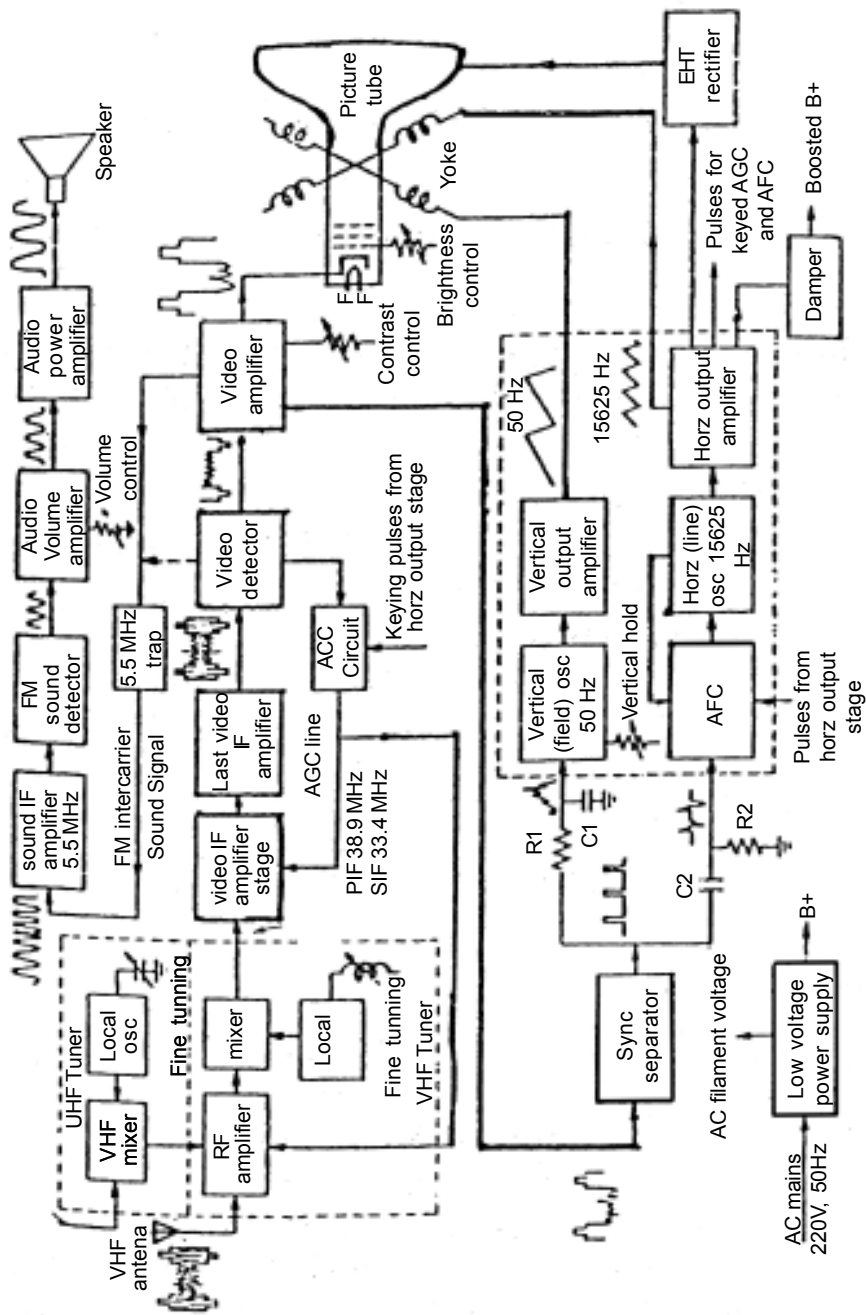

**Fig.2. BLOCK DIAGRAM OF TELEVISION RECEIVER**

### EXPERIMENT NO - 3

## RECTIFICATION OF SNOW PICTURE FAULT AND OPERATION OF A TV RECEIVER

### Aim

To rectify the fault of snow picture and operate the given TV Receiver

### Components Required

S.No.	Name of the Component/ Apparatus	Quantity
1.	TV Receiver	1
2.	Multimeter	1

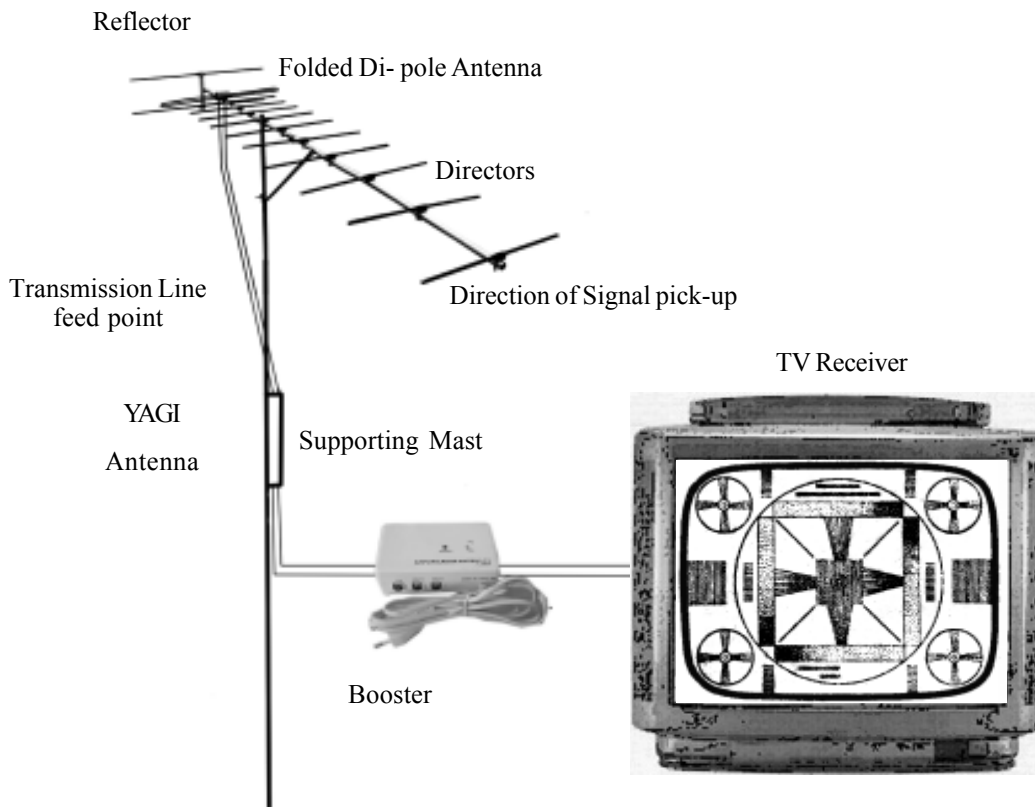

**Fig.3 : TV Screen show the snow picture**

### Identification of the Fault in given TV Receiver

1. Switch 'ON' the TV receiver.
2. If, the picture on the screen is with Snow and noisy Sound, go to the next step.
3. It confirms the receiver has Snow picture fault.

### Test the stages of the TV Receiver

1. First switch ON the TV receiver. The Picture on the screen is Snowy one.
2. First check the TV antenna and its related parts, whether it is in correct direction.

3. Then, check the feeder wire and booster for their functionalities.
4. Check the input and output pins of the TV receiver, for their correctness.
5. Check the tuner connection and measure the voltage at B+, AGC (Automatic Gain Control)
6. If the tuner is under fault, remove the tuner and solder a new one.
7. Then Switch ON the TV Receiver The Picture on the Screen is in good Condition with Normal Sound.

### **Result**

Thus rectification of the given Snow picture fault in the receiver was done and normal operation was ensured.

## **EXPERIMENT NO - 4**

### **RECTIFICATION OF NO COLOUR FAULT AND OPERATION OF A TV RECEIVER**

#### **Aim**

To rectify the no colour fault and operate the given colour TV Receiver.

#### **Components Required**

<b>S.No.</b>	<b>Name of Component/Apparatus</b>	<b>Quantity</b>
1.	Colour TV Receiver	1
2.	Multimeter	1

#### **Identification of the Fault given in a TV Receiver**

1. Switch ON the TV receiver.
2. The picture on the screen with no colour.
3. Adjust the colour Control. There is No Colour picture on the screen.
4. Switch OFF the TV Receiver immediately and confirm No Colour Picture fault on the Receiver, with colour control adjustment.

#### **Test the stages of the TV receiver (Referring to the figure 4)**

1. Switch ON the TV receiver
2. There is no colour on the picture
3. First check the antenna and its parts
4. Check the RF socket and related parts
5. Check the fine tuning control in the tuner
6. Check the chromo band pass amplifier
7. Check the working condition of colour killer circuit

### **Result**

Thus the 'no colour' fault in a Colour TV Receiver was rectified bringing it to the normal operation.

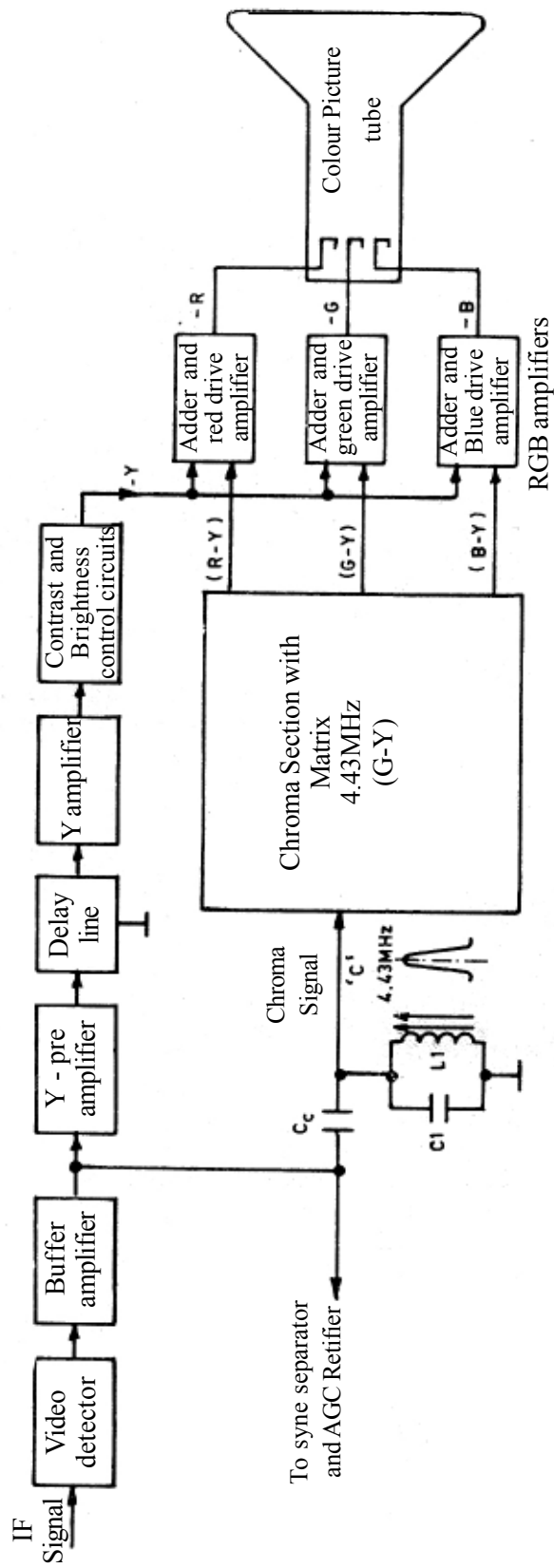

Fig.4 : BLOCK DIAGRAM OF COLOUR PICTURE STAGE

## EXPERIMENT NO - 5

### RECTIFICATION OF THE RED RETRACE LINE FAULT AND OPERATION OF A COLOUR TV RECEIVER

#### Aim

To rectify the Red Retrace line fault and operate the colour TV Receiver.

#### Components Required

S.No.	Name of Component/ Apparatus	Quantity
1.	Colour TV Receiver	1
2.	Multimeter	1

#### Identification of the fault in given TV receiver

1. Switch ON the TV receiver.
2. There is no picture on the screen but red retrace lines appear on the screen.
3. Switch OFF the receiver immediately and confirm red retrace lines fault on the receiver.

#### Test the stages of the TV Receiver (Referring to figure 5)

1. Switch ON the TV receiver.
2. Only red retrace lines appear on the Screen.
3. Measure the voltage at the red cathode if the voltage is low.
4. Check the components related to red cathode.
5. Check the IC and transistors related to red cathode.
6. Check the picture tube base.
7. If the base of the picture tube is fault, remove and solder the new one.

#### Result

Thus the fault in a colour TV receiver was rectified (Red Retrace Lines) and bringing it to the normal operation.

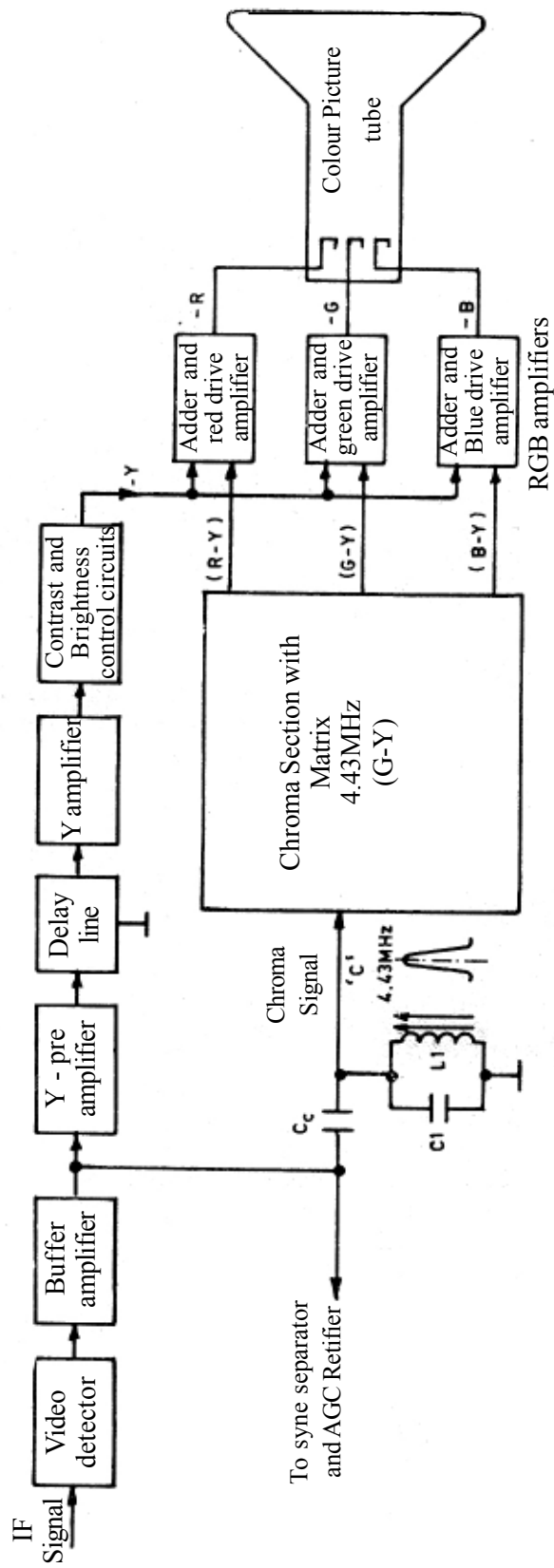

Fig.5: BLOCK DIAGRAM OF COLOUR PICTURE STAGE

## **EXPERIMENT NO - 6**

### **RECTIFICATION OF THE GREEN RETRACE LINES FAULT AND OPERATION OF A COLOUR TV RECEIVER**

#### **Aim**

To rectify the Green Retrace lines fault and operate the Colour TV receiver.

#### **Components Required**

<b>S.No.</b>	<b>Name of Component/Apparatus</b>	<b>Quantity</b>
1.	Colour TV Receiver	1
2.	Multimeter	1

#### **Identification of the fault in given TV receiver**

1. Switch ON the TV receiver.
2. There is no picture only green retrace lines on the screen.
3. Switch OFF the receiver immediately and confirm green retrace lines fault in the given Receiver.

#### **Test the stages of the TV receiver (Referring to the figure 6)**

1. Switch 'ON' the TV receiver
2. Only green retrace lines on the Screen.
3. Measure the voltage at the green cathode if it is correct.
4. Check the components related to green cathode.
5. Check the IC and transistors, related to green cathode
6. Check the picture tube base.
7. If the base of the picture tube is fault, remove and solder the new one.

#### **Result**

Thus the fault in a colour TV receiver was rectified (Green Retrace Lines) and bringing it to the normal operation.



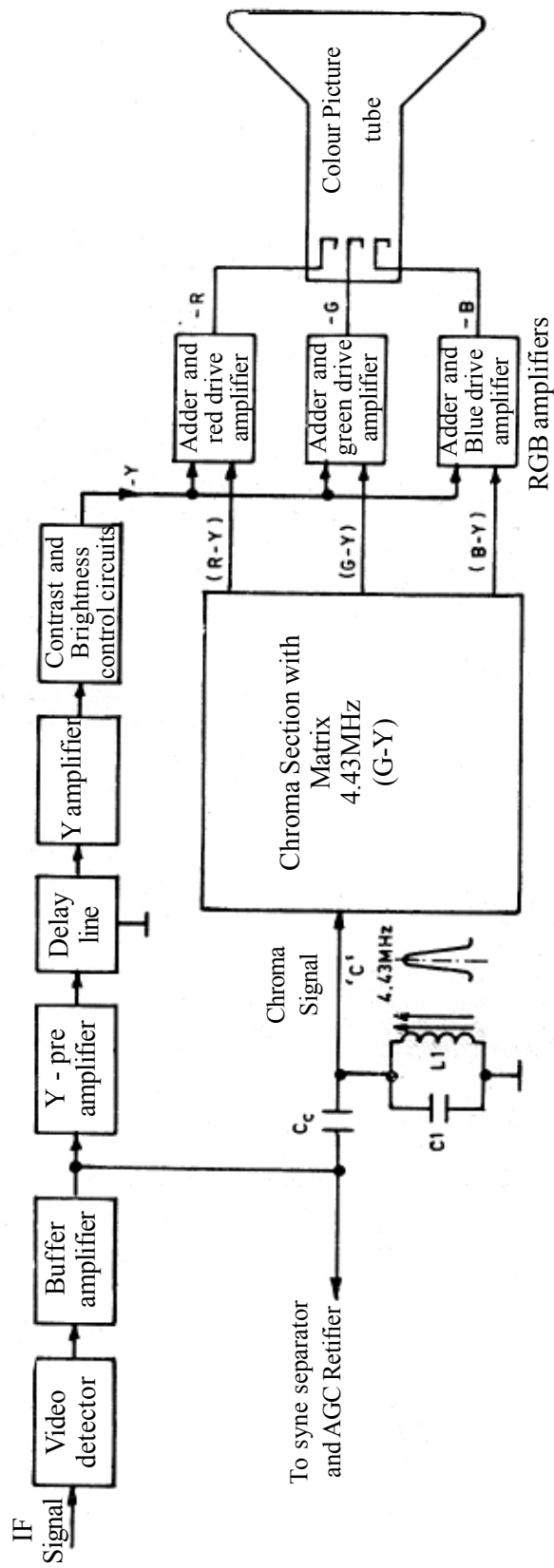

Fig. 6 : BLOCK DIAGRAM OF COLOUR PICTURE STAGE

## EXPERIMENT NO - 7

### RECTIFICATION OF BLUE RETRACE LINES FAULT AND OPERATION OF A COLOUR TV RECEIVER

#### Aim

To rectify the blue retrace lines fault and operate the Colour TV receiver.

#### Components Required

S.No.	Name of Component/Apparatus	Quantity
1.	Colour TV Receiver	1
2.	Multimeter	1

#### Identification of the Fault in a given TV receiver

1. Switch ON the TV receiver.
2. There is no picture only blue retrace lines on the screen.
3. Switch OFF the receiver immediately and confirm blue retrace lines fault given TV receiver.

#### Test the stages of the TV Receiver (Referring to the figure 7)

1. Switch 'ON' the TV receiver
2. Only blue retrace lines on the screen.
3. Measure the voltage at the blue cathode if it is low
4. Check the components related to blue cathode.
5. Check the IC and Transistors, related to blue cathode
6. Check the picture tube base.
7. If the picture tube base is fault remove and solder the new one.

#### Result

Thus the fault in a colour TV receiver (Blue retrace lines) and bringing it to the normal operation.

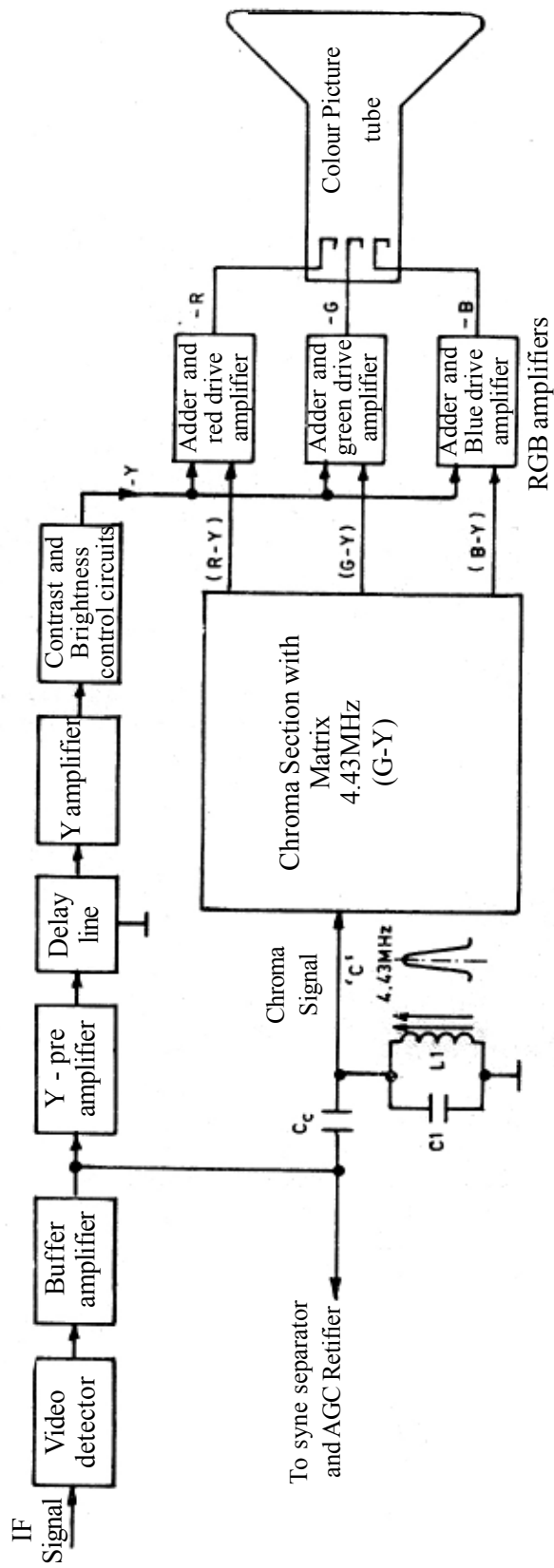

Fig. 7 : BLOCK DIAGRAM OF COLOUR PICTURE STAGE

## EXPERIMENT NO - 8

### RECTIFICATION OF THE HORIZONTAL LINE FAULT AND OPERATION OF A TV RECEIVER

#### Aim

To rectify the Horizontal line fault and operate the TV Receiver.

#### Components Required

S.No.	Name of Component/Apparatus	Quantity
1.	TV Receiver	1
2.	Multimeter	1

#### Identification of the fault in given TV receiver

1. Switch ON the TV receiver.
2. There is no picture but only horizontal line on the screen.
3. Switch OFF the receiver immediately and conform horizontal line fault on the TV receiver.

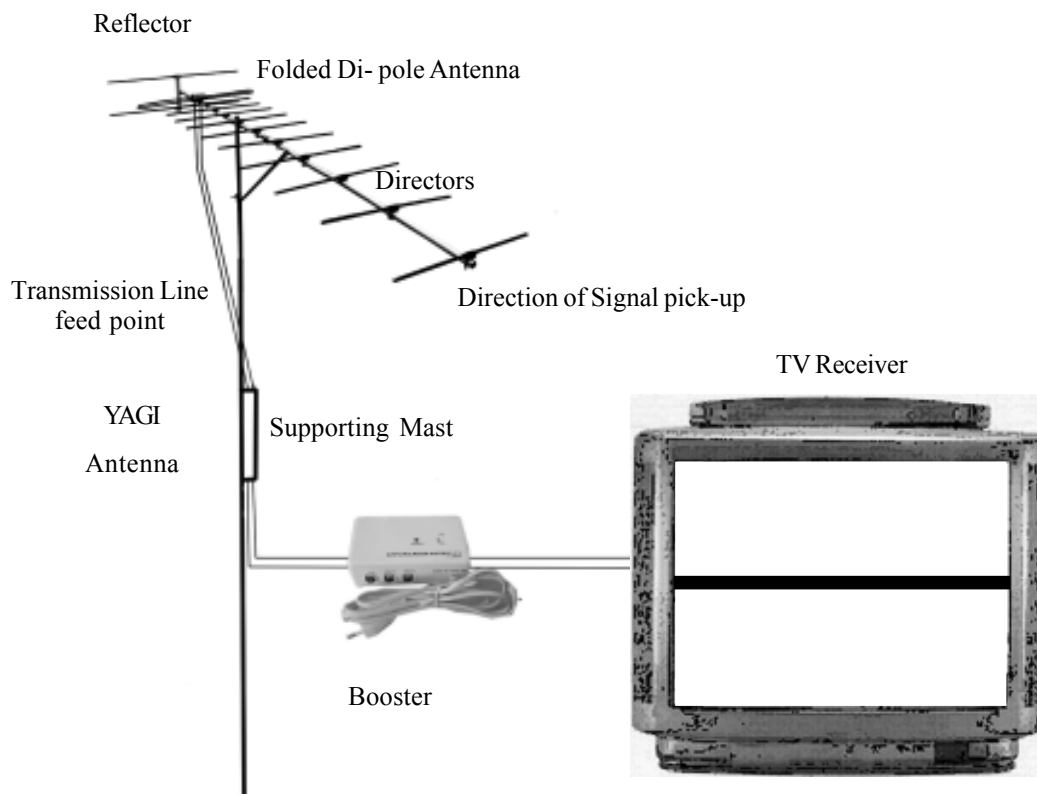

**Fig.8 : TV Screen shows the horizontal line**

#### Test the stages of the TV receiver

1. Switch ON the TV receiver

2. There is no picture only horizontal line on the screen.
3. Confirm the fault is in the vertical sweep section.
4. Touch the vertical preset with a screw driver the horizontal line on the screen to be oscillate or expand, confirm the fault is at vertical oscillator. Measure the voltage at vertical oscillator stage if it is correct.
6. Check the vertical output stage and check the connection at vertical deflection yoke coil then the check the condenser, if it is short or open, remove the condenser and solder new one.
7. Switch ON the TV receiver. The raster on the screen is normal.

### **Result**

Thus the horizontal line fault in the TV receiver was rectified and bringing it to the normal operation.

## **EXPERIMENT NO - 9**

### **RECTIFICATION OF A VERTICAL LINE FAULT AND OPERATION OF A TV RECEIVER**

#### **Aim**

To rectify the vertical line fault and operate the given TV receiver.

#### **Components required.**

<b>S.No.</b>	<b>Name of Component/Apparatus</b>	<b>Quantity</b>
1.	TV Receiver	1
2.	Multimeter	1

#### **Identification of the fault in a given TV receiver.**

1. Switch ON the TV receiver.
2. There is no picture, only vertical lines are present on the screen.
3. Switch OFF the receiver immediately and confirm vertical line fault on the TV receiver.

#### **Test the stages of the TV receiver**

1. Confirm the fault is in the Vertical sweep section.
2. Check the connection of vertical deflection yoke coil if it is correct
3. Check the vertical deflection coil with multimeter if it is correct.
4. Check the vertical linearity coil. if it is correct. Check the condenser connected series to vertical deflection coil, If the condenser is under short or open remove it and solder with new one of same value.
8. Switch ON the TV receiver. The raster on the screen is normal.

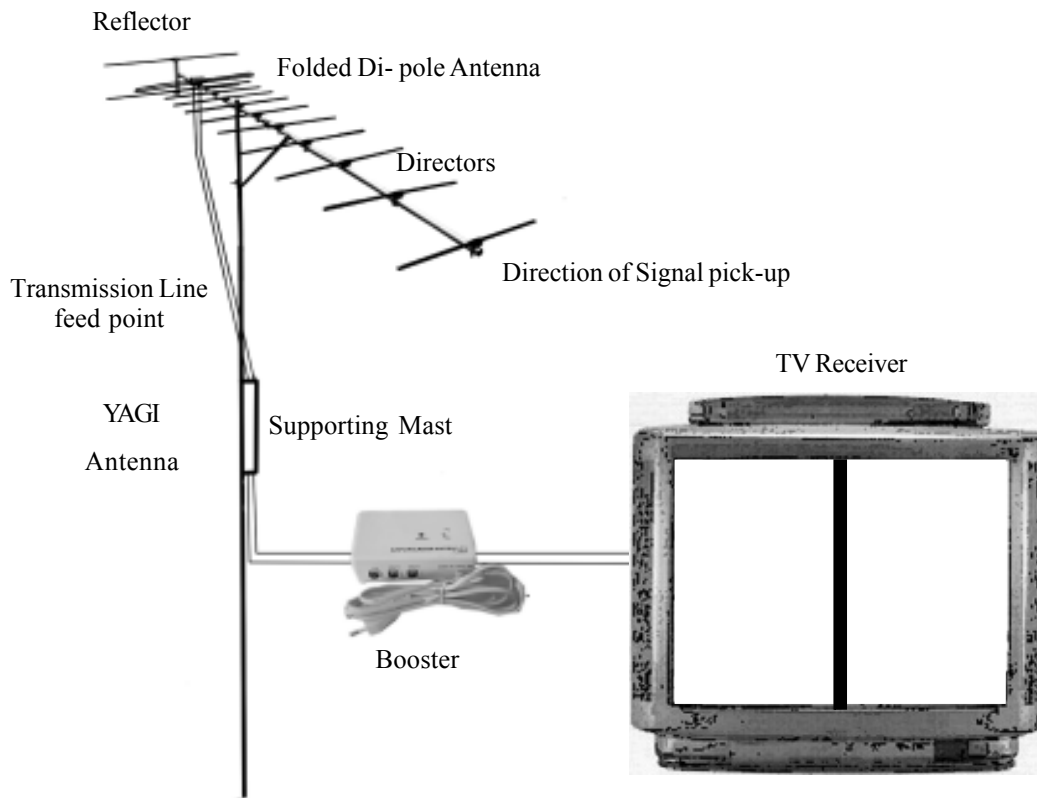

**Fig.9 : TV Screen shows the vertical line**

**Result**

Thus the vertical line fault in the given TV receiver was rectified and bringing it to the normal operation.

**EXPERIMENT NO - 10**

**RECTIFICATION OF THE HEIGHT LESS PICTURE FAULT AND OPERATION OF A TV RECEIVER**

**Aim**

To rectify the heightless picture fault and operate the TV Receiver.

**Components Required**

S.No.	Name of Component/Apparatus	Quantity
1.	TV Receiver	1
2.	Multimeter	1

**Identification of the fault in the given TV receiver**

1. Switch ON the TV receiver.
2. The picture shown in the screen is heightless.
3. Switch OFF the receiver immediately and conform the fault is in the vertical stage.

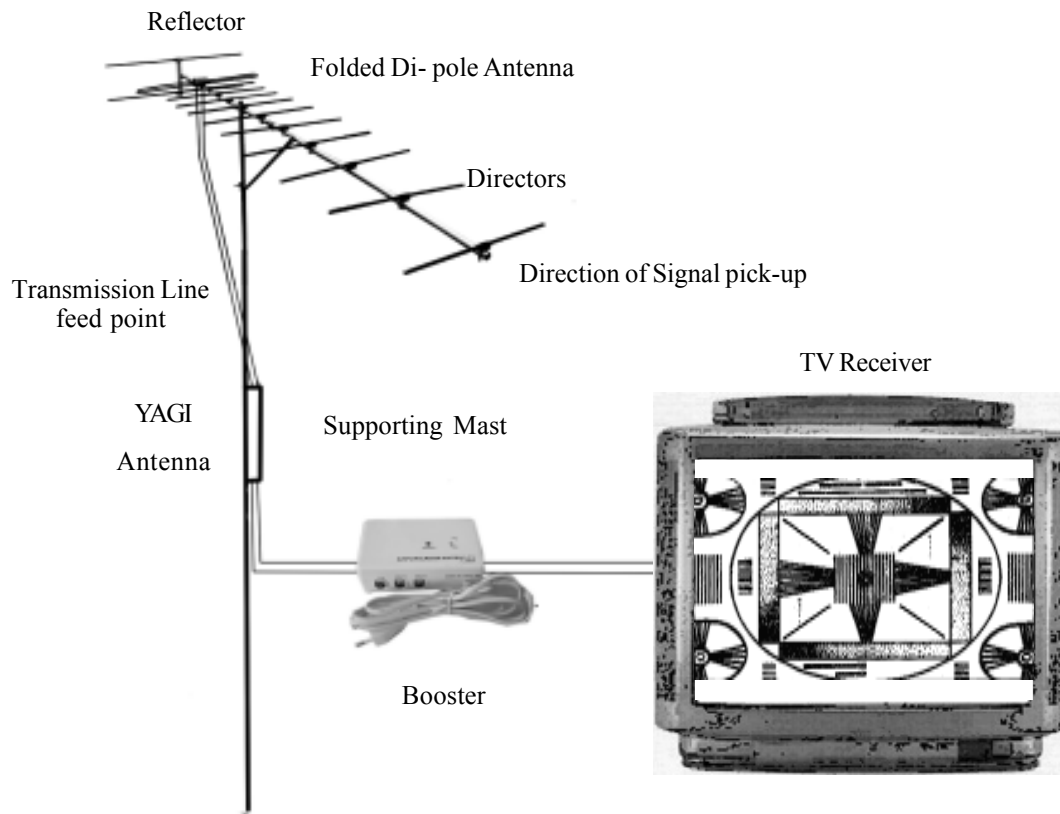

**Fig.10 : TV Screen shows the heightless Picture**

### **Test the stages of the TV receiver**

1. Height less picture on the screen confirms the fault is in the vertical stage.
2. Measure the voltage at the Vertical stage. If it is correct,
3. Adjust the vertical height control preset if there is no change in the picture height,
4. Check the condenser connected series to vertical deflection yoke coil if it is correct
6. Check the transistors, condensers and resistor connected at vertical output stage if it is correct,
7. Measure the voltage at IC pins connected in the vertical output stage. If the voltage is low remove it and solder the new one.
8. Switch ON the TV receiver. The picture on the screen is in normal height.

### **Result**

Thus the heightless picture fault in a TV receiver was rectified and bringing it to the normal operation.

## EXPERIMENT NO - 11

### RECTIFICATION OF THE NO SOUND WITH NORMAL PICTURE FAULT AND OPERATION OF A TV RECEIVER

#### Aim

To rectify the No Sound with normal picture fault and operate the TV Receiver.

#### Components Required

S.No.	Name of Component/Apparatus	Quantity
1.	TV Receiver	1
2.	Multimeter	1

#### Identification of the fault in a given TV receiver

1. Switch ON the TV receiver.
2. Picture on the screen is normal but no sound.
3. Switch OFF the receiver and confirm. The fault is in sound section.

#### Test the stages of the TV receiver

1. The picture on the screen is normal but no sound, confirms the fault is in the audio stage.
2. Measure the voltage at the audio amplifier and output stages if it is correct, go to next step.
3. Check the connection at the speaker and check the voice coil with multimeter, If it is correct,
4. Measure the voltage at IC pins connected in audio amplifier and output stage, if it is correct,
5. Check the volume control if it is defective remove it and solder new one.
6. Now the receiver screen shows the clear picture with sound.

#### Result

Thus the no sound fault in a given TV receiver was rectified and bringing it to the normal operation.



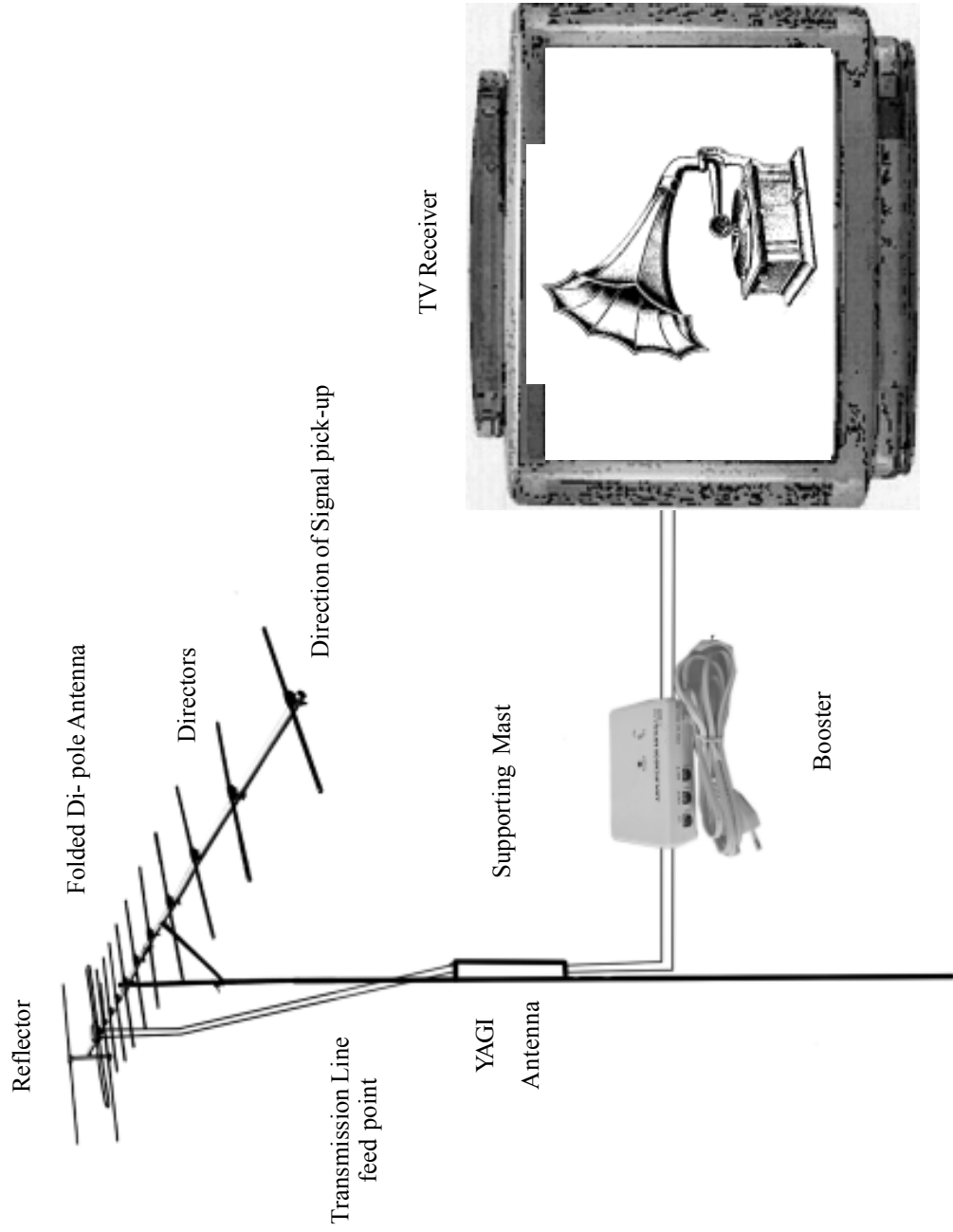

**Fig. 11 : No Sound with a normal picture in a TV receiver**

## **EXPERIMENT NO - 12**

### **RECTIFICATION OF THE RETRACE LINES FAULT AND OPERATION OF A TV RECEIVER**

#### **Aim**

To rectify the retrace lines fault and operate the given TV Receiver.

#### **Components Required**

<b>S.No.</b>	<b>Name of the Component/Apparatus</b>	<b>Quantity</b>
1.	TV Receiver	1
2.	Multimeter	1

#### **Identification of the fault in a given TV receiver**

1. Switch ON the TV receiver.
2. There is no picture only retrace lines on the screen.
3. Switch OFF the receiver immediately and confirm retrace lines fault is in the receiver.

#### **Test the stages of the TV receiver**

1. There is no picture only retrace lines on the screen.
2. Check the video output transistor and related parts and measure the voltage if it is correct. measure the voltage at picture tube grid G1 and G2, if it is correct,
5. Check the picture tube filament and cathode if it is short circuited remove it with proper way.

#### **Result**

Thus the retrace lines fault in a given TV receiver was rectified and bringing it to the normal operation.

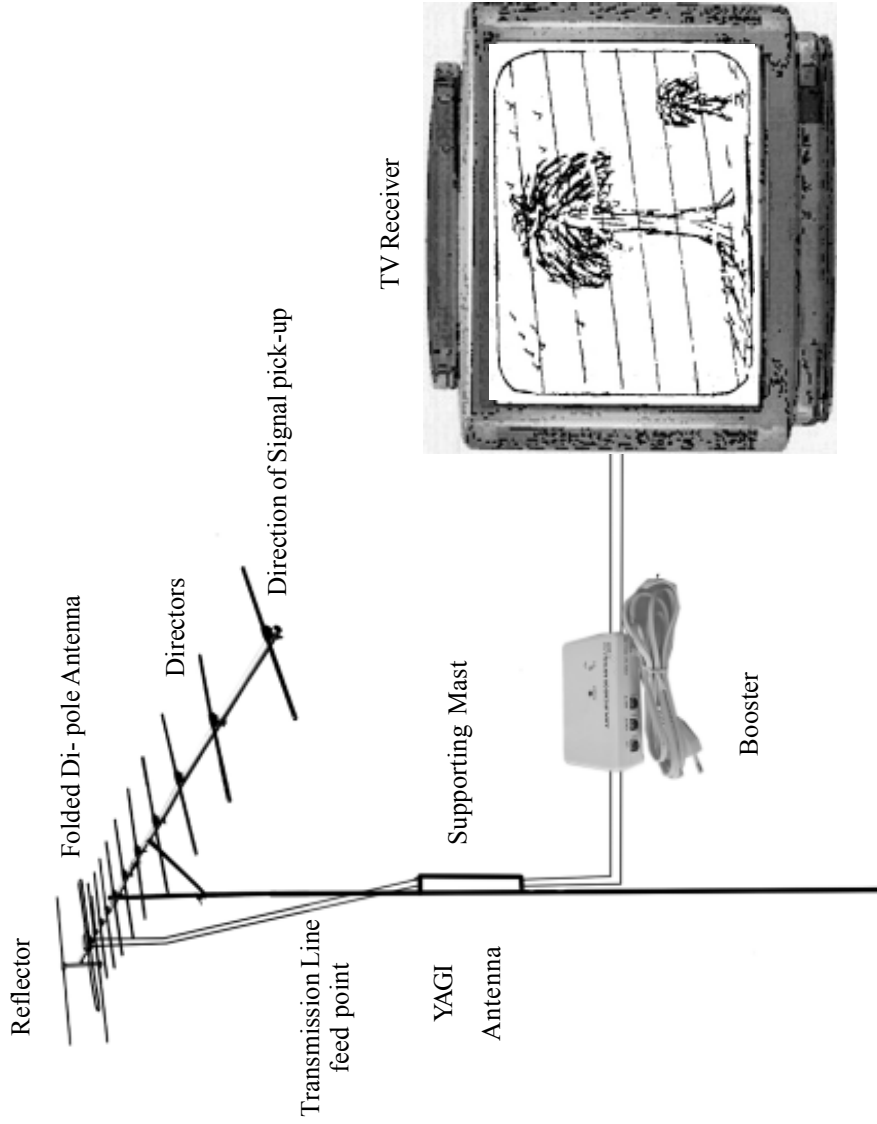

**Fig. 12 : RETRACE LINES FAULT IN A TV RECEIVER**

## EXPERIMENT NO - 13

### FIND AND RECTIFY THE DEAD FAULT- IN A DVD PLAYER

#### Aim

To find the dead fault in a DVD player and rectify.

#### Components required

S.No.	Name of Component/Apparatus	Quantity
1.	TV Receiver	1
2.	DVD player	1
3.	MP3 disc	1
4.	Multimeter	1

#### Identification of the fault in a DVD Player.

1. First connect the DVD player with TV receiver and switch ON.
2. There is no motion in the DVD Player. It seems to be dead.
3. So it is confirm dead fault is occur in the DVD player.

#### Testing

1. Check the main cords with multimeter, if it is correct,
2. Check the power supply transformer, if it is correct,
3. Check the bridge diodes, filters and regulator Ic.
4. It is conform the regulator Ic is fault.
5. So replace the Ic with new one.
6. Now operate the player.
7. The player function successfully.

#### Result

Thus the fault the DVD Player was rectified and bring it to the normal operation.

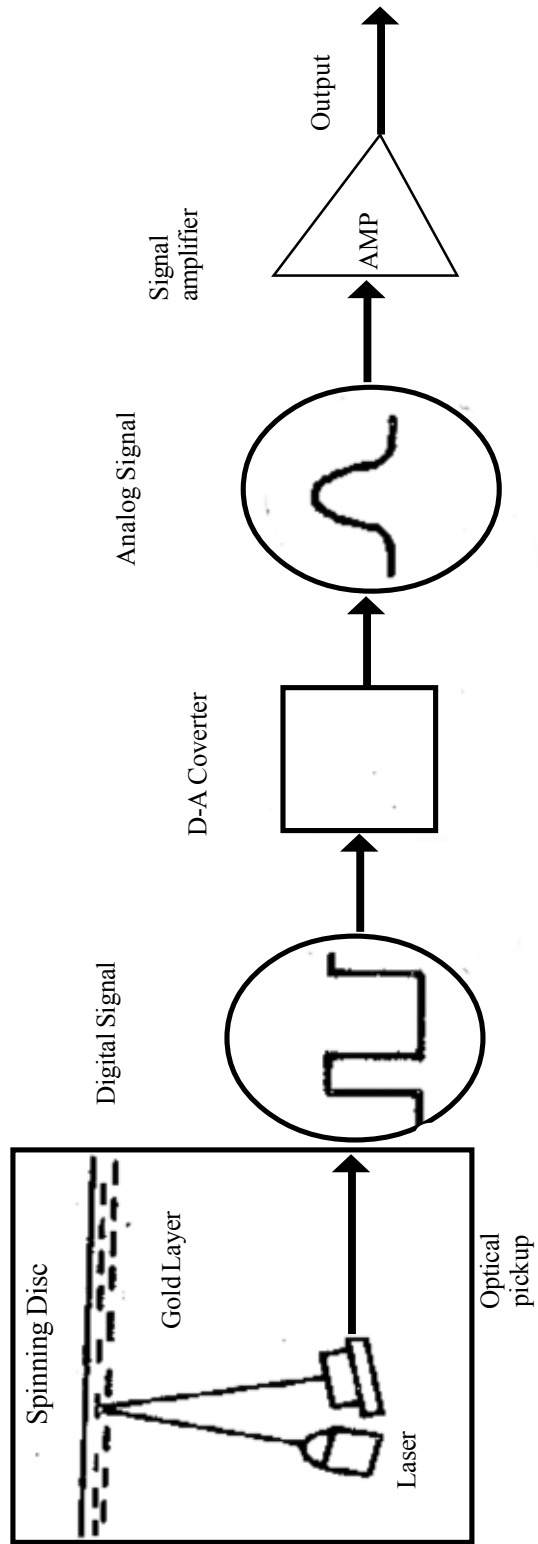

**Fig. 13 : Block diagram of DVD player**

## EXPERIMENT NO : 14

### IDENTIFICATION OF THE NO DISC FAULT AND OPERATION OF A DVD PLAYER

#### Aim

To Identify the no disc fault of in a DVD player and rectify.

#### Components required

S.No.	Name of the Component/Apparatus	Quantity
1.	DVD Player	1
2.	MP3 disc	1
3.	Television	1
4.	Multimeter	1

#### Identification of the fault in a given DVD player

1. Connect a required power supply with DVD player and television.
2. Make the connection with suitable probes between DVD and with television.
3. Switch ON both the T.V and DVD.
4. Open the DVD disc door and keep a MP3 disc.
5. DVD and TV shows "No-disc" in the screen.
6. So confirm the fault is "No-disc".

#### General reason for this type of fault

1. In DVD player the disc is in wrong position (up and down).
2. Driver (or) motor speed is not enough.
3. In DVD player, the laser beam is not fall on the disc.
4. The optical lens in the player does not focus the laser beam which fall on the disc.
5. So it is confirm the optical lens is fault.

#### Procedure of rectifying the faults

1. It is found that only the optical lens is fault.
2. So replace the fault lens with new (same power) lens.
3. Now the disc is playing and the screen shows the picture.

#### Result

Thus the "No-disc" fault was identified and rectified.

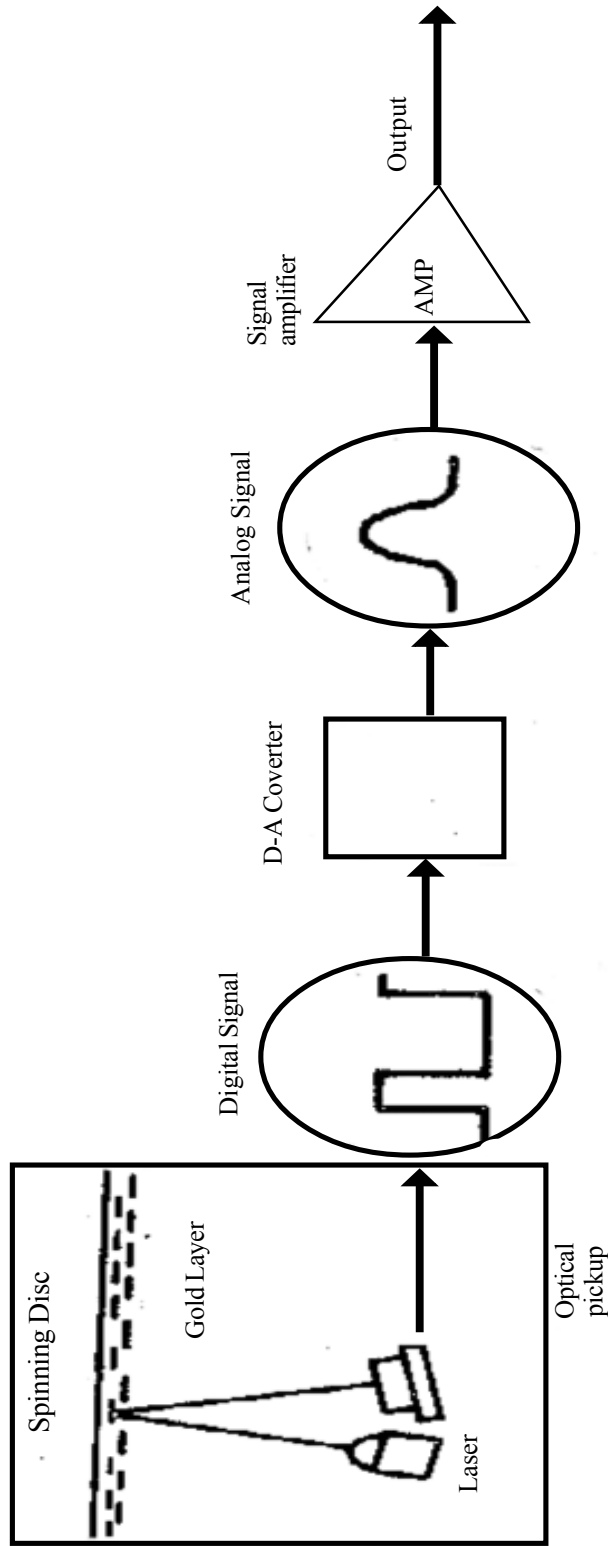

**Fig. 14 : Block diagram of a DVD player**

## EXPERIMENT NO -15

### STUDY OF CELL PHONES AND ITS MAINTENANCE

#### Aim

To know about the working of the cell phone and its maintenance.

#### Components required

S.No.	Name of Component/ Apparatur	Quantity
1.	Cell phone	1

#### Principle of Cell phone

Cell phone provides a wire less service which is hand held phone with built in antennas while we talk in a cell phone, it registers our voice and converts the sound into radio waves. The waves travel through the air and reach the base station which send the call though the network and makes the contact with the person whom we want to speak.



#### Keys and parts of the Cell phone

##### 1. ON and OFF

To switch the phone ON/OFF, Press and hold the power key.

##### 2. Display

When we switch on the phone we get the configuration settings on the display like

1. Singal strength 
2. Battery change status 
3. Indicators (Message, Lock, alarm etc..)
4. Name of network
5. Time and Date
6. Function of left, right and middle Navigator (Navi) Key.

##### 3. Key pad

Press the numbers in the key pad to call the person

##### 4. Call key

When we want to make a call to a person, select the number from key pad an call register which we already kept in the save mode. then press the call key.

##### 5. Navikey

It is a 4-way scroll key and middle set section key. Using this we can assign the other function from a predefined list.

Select menu > Settings > My Shortcuts > Navigation

##### 6. Left and right selection key

To select a function from the list, Select menu > Settings > My Shortcuts > left selection key or right selection key. To Select add or remove left key is used, To exit the function right key is used.



## 7. END key

After the speech ends we press the end key at once. we also switch off the phone using this key.

## 8. Microphone

We Speak through the micro phone which is in the lower side of the cell phone. It convert the sound wave into electrical wave or radio wave.

## 9. Charger Connector

We can charge the cell phone battery using this provision the cell phone battery using provision kept on the sides. We connect the charge wire.

## 10. FM Connector

FM radio depends on antenna other than the wireless device antenna. A Compatible head set a enchcement needs to attached, for the FM radio to function properly.

## 11. Ear piece Speaker

We can hear the speech through the speaker which is kept on the upper side of phone.

## 12. Camera Lens

Take images or video clips with the built in cameras. To use the still picture function select menu - media - camera. Cell phone can capture picture resolution up to given data. The phone saves the video clips on the memory card or in the phone memory.

## Install SIM card and battery

To remove the back cover of the device, press and slide the cover. open the SIM card holder, insert the SIM card with backside and close the SIM card holder. The same way, observe the battery contacts and insert the battery. slide the back cover into its place.

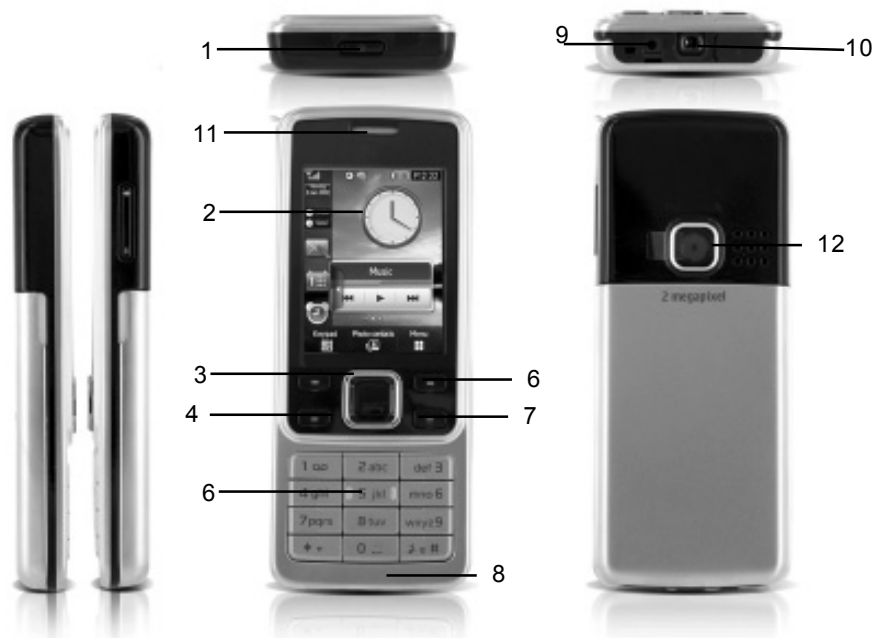

**Fig. 15 : Keys and Parts of Cell Phone**

- 1 On/Off
- 2 Display
- 3 Left and right selection key
- 4 Navi Key: 4-way scroll key and middle selection
- 5 Cell key
- 6 Keypad
- 7 End key
- 8 Microphone
- 9 Charger connector
- 10 Audio connector
- 11 Speaker
- 12 Camera

### **Maintenance of Cell phones**

The following suggestions will help to protect the cell phones.

1. Keep the cell phone in a dry place, If it does get wet remove the battery and allow the device to dry completely.
2. Do not use or store the device in dusty and dirty areas.
3. Do not store the device in hot or cold area.
4. Do not attempt to open the device unless it is instructed.
5. Do not drop, knock, or shake the device, rough handling can break internal circuit and bounds the fine mechanics.
6. Do not use hard chemicals, cleaning solvents or strong detergents to clean.
7. Do not paint the device.
8. Use a soft, clean, dry cloth to clean.
9. Use only approved replacement antennas.
10. Always power off the device then connect and disconnect the charger.
11. Do not talk while charging the mobile.

### **Result**

Thus we studied about the cell phones and its manitenance.

## EXPERIMENT NO - 16

### STUDY OF TV AND DVD REMOTE AND ITS MAINTENANCE

#### Aim

To study of TV and DVD remote control and how to maintain it.

#### Components required

S.No.	Name of Component/Apparatus	Quantity
1.	DVD Player	1
2.	DVD remote control	1
3.	TV remote control	1
4.	TV receiver	1

#### Introduction

TV and DVD are operated by remote controls. Once it is switched on the screen is played. It controls the powers of the players with a certain distance.

#### Structure of TV and DVD remote .

It is in the shape of slim cuboids and is made of plastic.

#### Important controls of TV Remote

1. Power ON / OFF
2. Menu
3. Channel (+ , -)
4. Time
5. Zoom
6. Games
7. Colour
8. Auto scanning
9. 0-9 Buttons
10. Volume (+ , -)

##### 1. Power ON / OFF

It is a red colour round button which is used to switch ON / OFF the set. When it is in ON position screen is displayed.

##### 2. Menu

On pressing the menu button, we can also select, channel, sound, picture using + or - buttons.

##### 3. Channel (+, -)

There is two buttons + and - , pressing + button, the next channel can be set. Pressing - button the previous channel can be set.

#### 4. Time

We can miss some important programme in such times. So we can store the time using the sleep button, automatically the programme is screened. Also we store the off time also itself the set is off.

#### 5. Zoom

We can adjust the picture on screen maximum level and minimum level using this button.



**TV Remote**



**DVD Remote**

#### 6. Game

There must be a game in a TV memory. We can select the game using this button.

#### 7. Colour

We can adjust the colour of picture which screened using this button.

#### 8. Auto Scanning

Using this button we can identify the numbers of the channels.

#### 9. 0-9 Buttons

We can select a particular channel using these 9 buttons one at a time.





## 10. Volume (+, -)

We can increase or decrease the volume by this + / - buttons.

### Procedure for Maintenance

1. We must use the remote control to switch ON/ OFF the TV.
2. The Distance between the remote and TV is minimum 7m.
3. We should not press two channel buttons at the same time.
4. Don't operate the remote at the backside of the T.V.
5. Often we change the channels and the volume, the remote will attained fault.
6. only DC supply must be used.
7. We must change the low power batteries at once.
8. Two batteries which we can use in the remote must be same (same company).
9. Don't use one is new and the other is old.
10. We could not put down the remote often and don't keep in wet places.

### IMPORTANT CONTROLS OF DVD REMOTE

1.  : We can switch on and off the system by using this button.
2. **DISPLAY** : It can screened the programmes which we want.
3. **DISC MENU** : It can send in or out of the selected programmes.
4. **OK** : It can allow the programmes.
5. **PRE**  : We can select the previous screen using this.
6. **RETURN / TITLE** : We go throw the previous stage or title.
7. **■STOP** : We could stop the play using this button.
8. **▶||PLAY / PAUSE** : We could temporarily stop or play the screen using this.
9. **SUBTITLE** : We can choose the language using this.
10.  : It has used to fast forward the play on the screen is ie. 2x,4x,8x,16x,32x.
11.  : We can screen the play slowly ie. 1/2,1/4,1/8,1/16 using this button.
12. **SET UP** : It can send out, and come back the menu system.
13. **NEXT** : We can change the play to next screen.
14. **MUTE** : We can switch off the sound temporarily.
15. **AUDIO** : It can select the voice of audio on channel

### Procedure for Maintain the Remote

1. We can operate the remote straightly with sensor.
2. Don't keep any objects between player and remote while operate.
3. We must use only standard batteries.
4. Batteries are connect with correct position of + and - .

### Result

Thus, we study the operation of the TV and DVD remote controls and also know how to maintained it.

## **EXPERIMENT NO - 17**

### **STUDY OF SMPS**

#### **Aim**

To study the SMPS power supply.

#### **SMPS Power Supply**

Monochrome and colour TV receiver has so many types of power supplies. SMPS power supply is one of it. It convert the AC input voltage to DC regulated power. SMPS power supply may be divided into five stages.

1. Input rectifier and filter.
2. High frequency switch.
3. Power Transformer
4. Output rectifier and filter
5. Control circuit.

#### **1. Input rectifier and filter**

The input rectifier stage rectify the AC 220 v, 50HZ to DC supply with bridge rectifier.

#### **2. High Frequency Switch**

In this stage MOSFET's are used as High Frequency switch the DC voltage is converted to square waves using chopper principle.

#### **3. Power Transformer**

This stage transformer is used to step up or step down the AC Voltage.

#### **4. Output rectifier and filter**

This stage rectify the AC voltage to required value of DC regulated power supply.

#### **5. Control Circuit**

This stage is used a feed back network which is connected to the output stage and high frequency switch.

#### **Result**

Thus we studied the working principle of SMPS power supply.

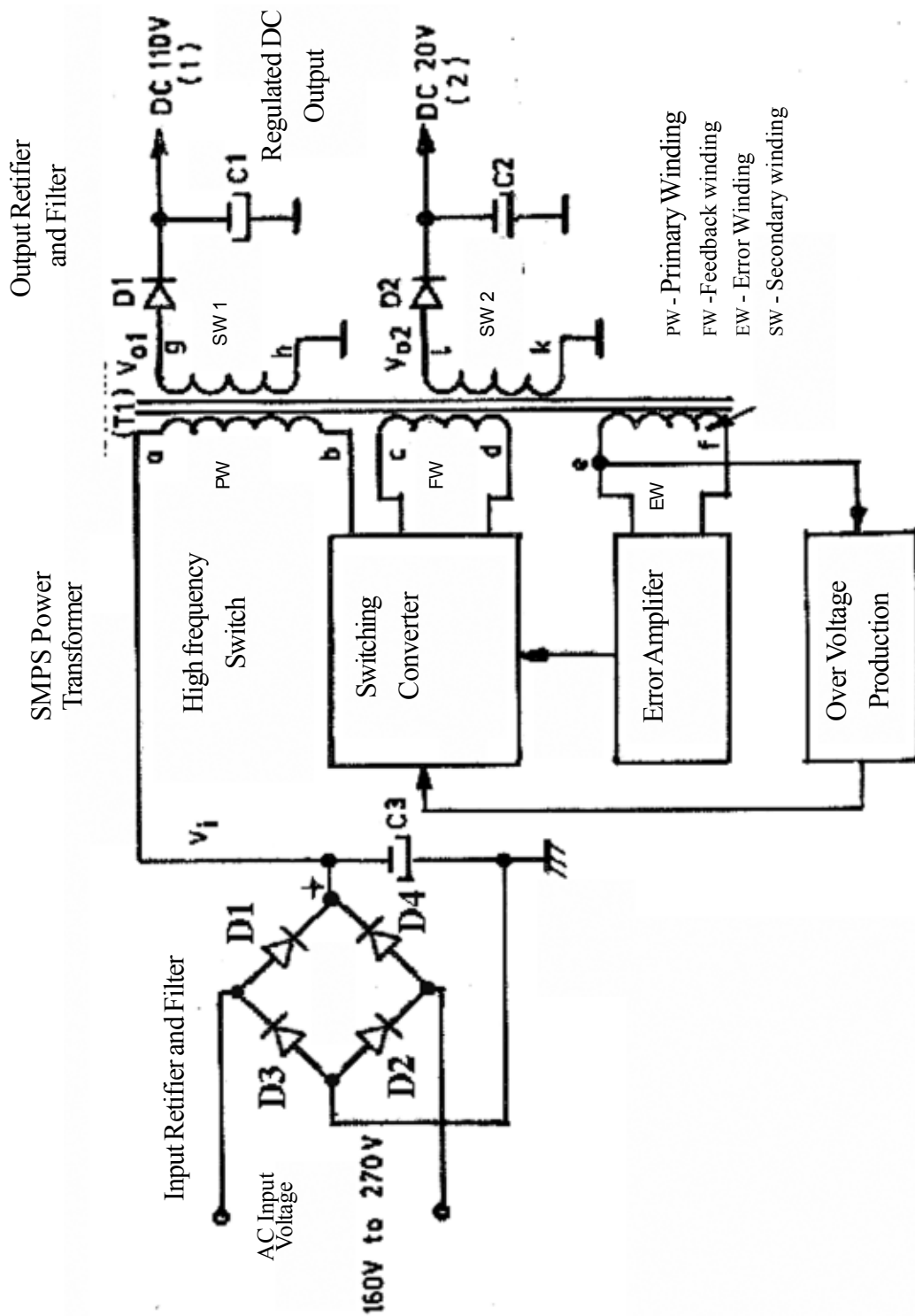

Fig. 17 : SMPS Power Supply